



MFJ ENTERPRISES

TELEPHONE (801) 323-5869 P. O. BOX 494 MISSISSIPPI STATE, MS 39762

HINTS IN OBTAINING MAXIMUM PERFORMANCE FROM ACTIVE AUDIO FILTERS

MFJ high performance active filter results from careful application of modern network synthesis theory and modern IC technology. The following hints will enable you to attain maximum performance.

● NO IMPEDANCE MATCHING REQUIRED

NO IMPEDANCE MATCHING IS REQUIRED for optimum filter response. However, the source impedance driving the filter should be less than one-tenth the filter input impedance. This requirement is generally satisfied without considering the source impedance since MFJ filters are designed for very high input impedance.

THE FILTERS CAN DRIVE 500 OHM OR GREATER LOADS, such as high impedance phones, without distortion. Lower impedances such as 8 ohm phones can also be driven. If distortion occurs, reduce the input signal level or transform the impedance up to 500 ohms or greater. For example, a miniature audio transformer (500 ohms to 8 ohms) can be used to couple 8 ohm phones to the filter.

● INSTALLATION OF FILTERS

THE SIMPLEST METHOD of using the CW and SSB filters is to plug the filter into the phone jack or connect it to the speaker terminals of your receiver or transceiver and use headphones at the filter output. This gives very satisfactory performance and is the normal mode of operation.

FOR FULL SPEAKER OPERATION, install the filter between audio stages as shown in Figure 1. Installation after the first gain stage helps to avoid the problems of possible oscillations, hum pickup, and noise.

SHIELDED CABLE AND PROPER GROUNDING MAY BE NECESSARY to prevent hum pickup and audio oscillations, particularly if the filter is used before a very high gain amplifier. The filter PC board may be physically mounted inside the receiver and power taken from the receiver.

CARE MUST BE TAKEN so DC bias conditions within the receiver audio amplifier are not upset (i.e. do not remove biasing resistors or place the filter between direct coupled stages, etc.).

DC VOLTAGES AT THE FILTER INPUT must not exceed the input capacitor rated voltage. DC voltage at the output must not exceed 1/2 of the filter power supply voltage.

SUMMARIZING, connection to the receiver output is recommended for simplicity of installation and for checking out the filter. For full speaker operation install the filter between audio stages. Alternately, a power amplifier can be installed after the filter to drive a speaker.

● POWER REQUIREMENTS

THE BX MODELS (filters installed in cabinets) require a 9 volt battery. Be sure to remove the cabinet top and install a battery before using.

ALL MFJ FILTERS (except the LPF-2) are designed to perform equally well from 6 VDC to 30 VDC. This may be supplied from batteries, a well filtered power supply, or "stolen" from the receiver.

IF A 500 OHM OR GREATER LOAD IS USED and distortion occurs but disappears at low volume, increase the power supply voltage (stay within the 30 volt limit).

● GROUNDING

PROPER GROUNDING IS NECESSARY, particularly if a battery or other floating power source (i.e. neither positive or negative side is at signal ground) is used. One side of the supply must be connected to signal ground. Generally, the negative side of the floating source is connected to the receiver chassis ground. If the CW filter is not connected to the receiver signal ground, a very broad response may occur instead of a very narrow response.

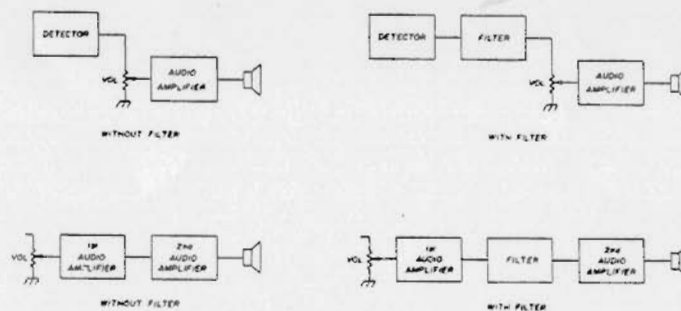

Fig. 1 - Method of connecting the CW and SSB filters. Better performance results if filters are inserted ahead of the audio amplifier.

● SYNOPSIS OF MFJ ACTIVE AUDIO FILTERS

CW FILTERS: CWF-2BX, CWF-2 ● 8 poles ● Bandwidths (selectable)-180, 110, 80 Hz ● Ultra steep skirts-60 db down 1 octave from center frequency of 750 Hz (80 Hz bandwidth) ● 400 or 1000 Hz center frequency optional CWF-3 ● 4 poles ● Bandwidth (selectable)-180, 110 Hz ● 30 db down 1 octave from 750 Hz center frequency

SSB FILTER: SBF-2BX, SBF-2 ● 8 poles, total ● Selectable (1.) high pass cutoff 47; and low pass cutoffs (2.) 2.5, (3.) 2.0, (4.) 1.5 KHz ● 120 db per decade rolloff in 1.5 KHz position

LOW PASS FILTER: LPF-1 ● 8 poles ● 160 db per decade rolloff ● Presettable cutoff 500 to 20,000 Hz ● 1 Meg input impedance LPF-2 ● Identical to LPF-1 except cutoff extends to DC, requires dual polarity supply LPF-4 ● 4 poles ● 80 db per decade rolloff ● Presettable cutoff 500 to 20,000 Hz

HIGH PASS FILTER: HPF-4 ● 4 poles ● 80 db per decade rolloff ● Presettable cutoff 300 to 20,000 Hz ● Remove high power low frequency speech components for increase talk power

WIDE BAND PASS FILTER: BPF-1 ● Consist of a LPF-4 and HPF-4 on 2x3 inch PC board ● Upper and lower cutoff frequency independently presettable for audio bandshaping

NARROW BAND PASS FILTER: NBP-2 ● 2 stages, each stage individually tunable from 300 to 3000 Hz (trim pots) ● 200 Hz bandwidth over tuning range ● Can be staggered tuned ● Excellent RTTY filters

NEW HIGH PERFORMANCE

CW Filter

MODEL CWF 2

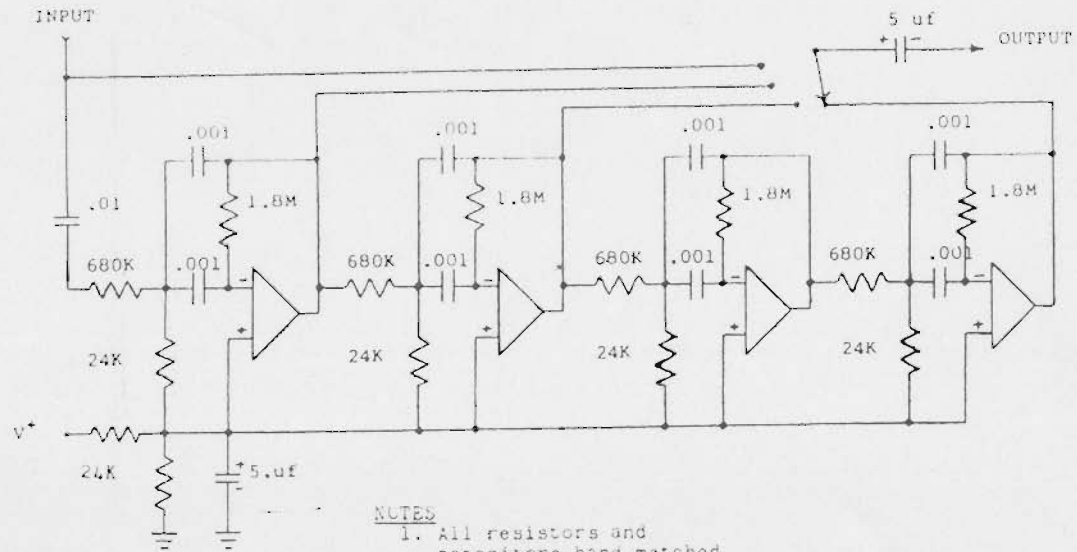

NOTES

1. All resistors and capacitors hand matched for same center freq.
2. Op amps are 747's.