

KG-620 VTVM

ASSEMBLY MANUAL

knight-kit

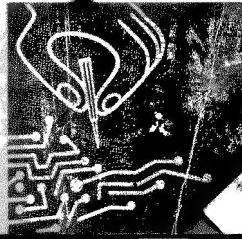

Thank You . . .

for your interest in Knight-Kits.

This Assembly Manual represents our many decades of experience in developing electronic kits which bring you outstanding performance at dollar-saving prices . . . and with maximum ease of construction.

As you go through the pages of this brochure, note how carefully each stage of construction is explained—how each diagram is magnified so that you almost have the feeling a good instructor is working at your side!

Knight-Kit's "do and check" method of kit-building insures accurate and simple assembly. Although your final product may represent a very complicated piece of electronic equipment, you will proceed with ease and assurance, step-by-step . . . and enjoy enormous satisfaction in your completed working unit.

Every Knight-Kit of your choice is available to you on the Allied Credit Fund Plan—

- No Money Down
- 24 Months To Pay
- Up To 50% Increased Buying Power

Your Knight-Kit purchase is backed with our exclusive and iron-clad guarantee—you must be *completely* satisfied or your purchase price is refunded!

It is always a pleasure to serve you.



A. D. Davis, President

ELECTRONIC VACUUM TUBE VOLTMETER KIT

FEATURES

- Push-Pull Balanced-Bridge Meter Circuit Assures Accuracy and Protection
- 11-Megohm Input Resistance Minimizes Circuit Loading—Gives True Readings
- Measures BOTH Peak-to-Peak and RMS AC Voltages in 7 Ranges Each
- Single Zero-Adjustment Control for all Functions and all Ranges
- Positive and Negative DC Function Switch Positions Eliminate Lead Reversal
- Zero-Center Scale for Alignment of TV and FM Discriminator Circuits
- Transformer-Type Power Supply for Line Isolation and Operating Safety
- Calibrates Without Removing Cabinet
- Film-Type 1% Precision Resistors

Outstanding in both performance and value . . . offering all the quality that years of experience and research in instrument development can provide . . . having all the modern, advanced features needed for all-around efficiency of electronics servicing . . . this is your Knight-Kit VTVM.

Provides entirely electronic, direct-reading measurement of AC voltage (BOTH Peak-to-Peak and RMS values), DC voltage, decibels and resistance on a rugged, highly legible, two-color 4½" full-view meter. Invaluable for signal tracing, for alignment, for voltage and resistance measurements in AM/FM radios or tuners, television and hi-fi sets, for checking frequency response, for continuity tests, and for servicing electrical equipment.

Feature highlights include: film-type 1% precision resistors and multipliers; low-leakage function and range switches; finest-grade printed circuit board; 3 separate test leads for AC-Ohms, DC, and Common; heavy-gauge steel case with rugged panel; pilot light; transformer-operated power supply for line isolation and safety; standard 1½-volt "C" battery; 200-microamp meter movement; carrying strap; and premium-quality parts.

Circuitry boasts: push-pull balanced-bridge for maximum accuracy and meter protection; DC polarity-reversing switching; 11-megohm input resistance to reduce circuit loading to a minimum and assure true readings; zero-center scale; direct-reading decibel scale; highly sensitive DC amplifier to allow resistance measurements as high as 1000 megohms using only the 1½ volt battery—eliminating danger to delicate apparatus under test; single zero-adjustment control for all functions and ranges; and calibration without removing internal chassis from cabinet.

Always look to Knight-Kit, established leader in professional test equipment design, for versatility, rugged construction, and proven dependability.

SPECIFICATIONS

DC Voltmeter:

Ranges.....	1.5, 5, 15, 50, 150, 500, and 1500 volts full scale.
Input Resistance.....	11 Megohms (1 Megohm in probe) on all ranges.
Circuit.....	Push - Pull balanced bridge with 12AU7 twin triode.
Accuracy.....	$\pm 3\%$ full scale.

AC Voltmeter:

RMS Ranges.....	1.5, 5, 15, 50, 150, 500, 1500 volts full scale.
Accuracy.....	$\pm 5\%$ full scale.
Peak-to-Peak Ranges.....	4, 14, 40, 140, 400, 1400, 4000 volts.

Ohmmeter:

Ranges.....	Center scale at 10 with multipliers $\times 1$, $\times 10$, $\times 100$, $\times 1000$, $\times 10K$, $\times 100K$, $\times 1Meg$.
-------------	---

Meter: $4\frac{1}{2}$ " 200 μA movement.

Multipliers: 1% precision type.

Tube Complement: 12AU7, twin triode me-
ter bridge.
6AL5, twin diode full
wave rectifier.

Power Supply: 110-125 volts, 60 cycles
AC.

Battery: 1.5 volt "C" battery.

HOW TO BUILD THE KNIGHT VTVM

Your KNIGHT VTVM uses a printed circuit which assures you that the VTVM will be an accurate, reliable test instrument regardless of age. A sheet of copper is bonded to a sheet of phenolic. When the wiring pattern has been determined, the unused portion of the copper sheet is etched off leaving an exact duplication of the engineering prototype. Exact duplication is one of the greatest advantages of printed circuits, and prevents variation in wiring and performance from instrument to instrument.

Your KNIGHT VTVM is all electronic. That is, the bridge circuit is used for every measurement of DC

voltage, resistance, and AC voltage after rectification by the full-wave rectifier.

The meter employed is an extremely stable, sensitive 200 microampere movement. The multipliers are 1% precision type. Overall accuracy of the DC functions is $\pm 3\%$ of full scale reading, and $\pm 5\%$ on AC functions. A wide choice of measurements is provided giving you seven ranges on DC, AC, and resistance. Both RMS and peak-to-peak AC voltages may be measured.

Your KNIGHT VTVM, through the use of the printed circuit, saves a great deal of tedious wiring, assures you of a finished instrument which compares closely to the original engineering model, and provides you with an instrument worth many times its low cost.

Before starting to build your KNIGHT VTVM, check each part against the Parts List on page 23. If you are unable to identify some of the parts by sight, locate them on the pictorial diagrams. Capacitor and resistor values, if not printed on the part, can be found with the aid of the color code chart.

Hardware is listed in the last part of the Parts List. To keep our kits at the lowest possible price, we frequently weigh hardware rather than to count it. Therefore, do not be concerned if more nuts and machine screws, for example, are supplied than are specified in the Parts List.

The only tools required for building your KNIGHT VTVM are: Long-nose pliers, diagonal cutters, screw-driver, set-screw driver, and a soldering iron.

Study the pictorial diagrams and note how the parts are mounted. These pictorial diagrams show the actual location of all parts and wiring. The schematic diagram shows how the parts are connected electrically and is helpful in understanding how the circuits work.

The step-by-step instructions were prepared by a skilled technician while he was actually building the KNIGHT VTVM. Therefore, they are the best and fastest way of assembling this instrument. We suggest that you read through the instructions before building the VTVM. This will enable you to familiarize yourself with the procedure and avoid possible errors. We invite you to use the blank parentheses, (), before each step to check it off after you have completed it.

Each step is clearly illustrated on an accompanying line drawing. Some builders prefer to "cross out" each wire and component on the drawings with a colored pencil after it is installed. While an excellent way to avoid mistakes, and highly recommended by us, this procedure results in drawings that are difficult to re-use. For this reason each wiring view is reproduced on a separate, folded sheet of paper.

You are now ready to build your KNIGHT VTVM.

THIS KIT MUST BE PROPERLY SOLDERED!

USE ENOUGH HEAT

This is the main idea of good soldering. Apply enough heat to the metal surfaces you are joining to make the solder spread freely, until the contour (shape) of the connection shows under the solder.

AN ELECTRONIC UNIT WILL NOT WORK . . . unless it is properly soldered. Read these instructions carefully to understand the basic ideas of good soldering.

Enough heat must be used so the solder can actually penetrate the metal surfaces, making an unbroken path over which electricity can travel. You are not using enough heat if the solder barely melts and forms a rounded ball of rough, flaky solder.

Use the Right Soldering Tool

A soldering iron in the 40-100 watt range is recommended.

Any iron in this range with a clean, chisel-shaped tip will supply the correct amount of heat to make a good solder connection. You may also use a solder gun but make sure the tip reaches full heat before you solder.

Keep the iron or gun tip brightly coated with solder. When necessary, wipe the hot tip clean with a cloth. If you are using an old tip, clean it before you start soldering. Use a fine file or steel wool to expose the bright metal. Heat the iron and immediately coat the tip with solder.

Use Only Rosin Core Solder

We supply the right kind of solder (rosin core solder). Do not use any other kind of solder! **Use of Acid Core Solder, Paste, or Irons Cleaned on a Sal Ammoniac Block will ruin any Electronic Unit and will Void the Guarantee.**

HERE'S HOW TO DO IT . . .

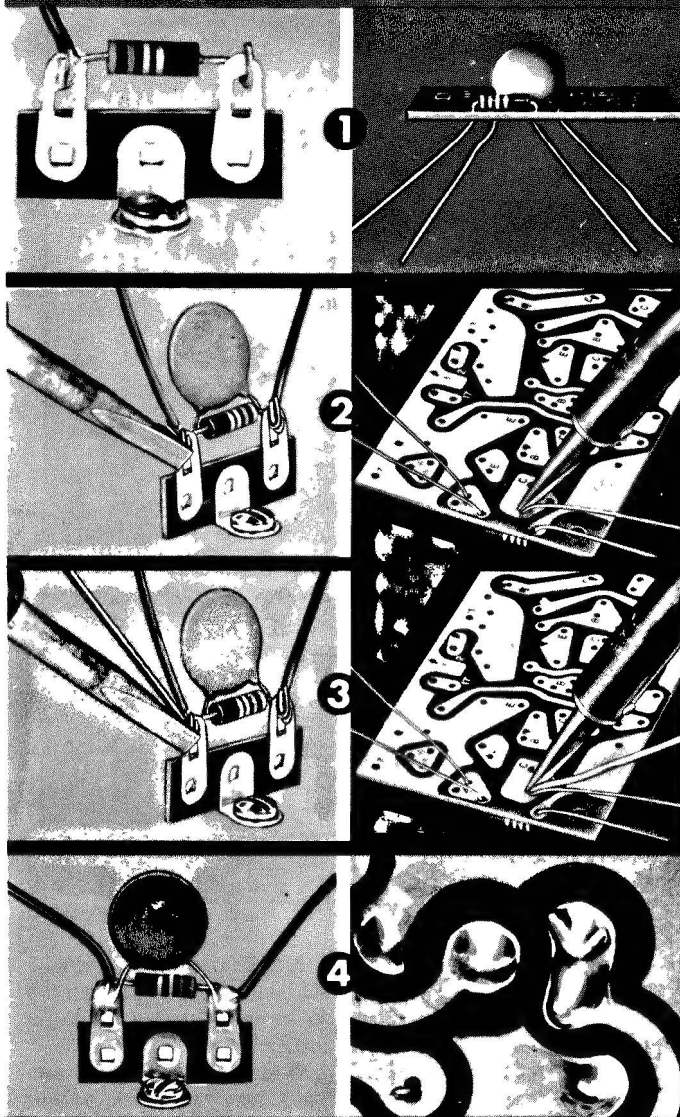

1. Join bare metal to bare metal; insulation must be removed. Make good mechanical connections and keep resistor and capacitor leads as short as possible, unless otherwise specified.

2. Coat the tip of a hot iron with solder. Then **Firmly Press the Flat Side of the Tip** against the parts to be soldered together. Keep the iron there while you . . .

3. Apply the solder between the metal to be soldered and the iron tip. Use only enough solder to flow over all surfaces of the connection, and all wires in the connection. Remove the iron.

Do Not Move Parts Until the Solder Hardens. If you accidentally move the wires as the solder is hardening, apply your iron and reheat.

4. Compare your soldering with the picture on this page. You have a good connection if your solder has flowed over all surfaces to be connected following the shape of the surfaces. It should appear smooth and bright and all wires in the connection should be well-soldered.

You Have Not Used Enough Heat: If your connection is rough and flaky-looking, or if the solder has formed a round ball instead of spreading.

The difference between good soldering (enough heat) and poor soldering (not enough heat) is just a few extra seconds with a hot iron firmly applied.

REMEMBER, LARGER METAL SURFACES TAKE A LONGER TIME TO HEAT.

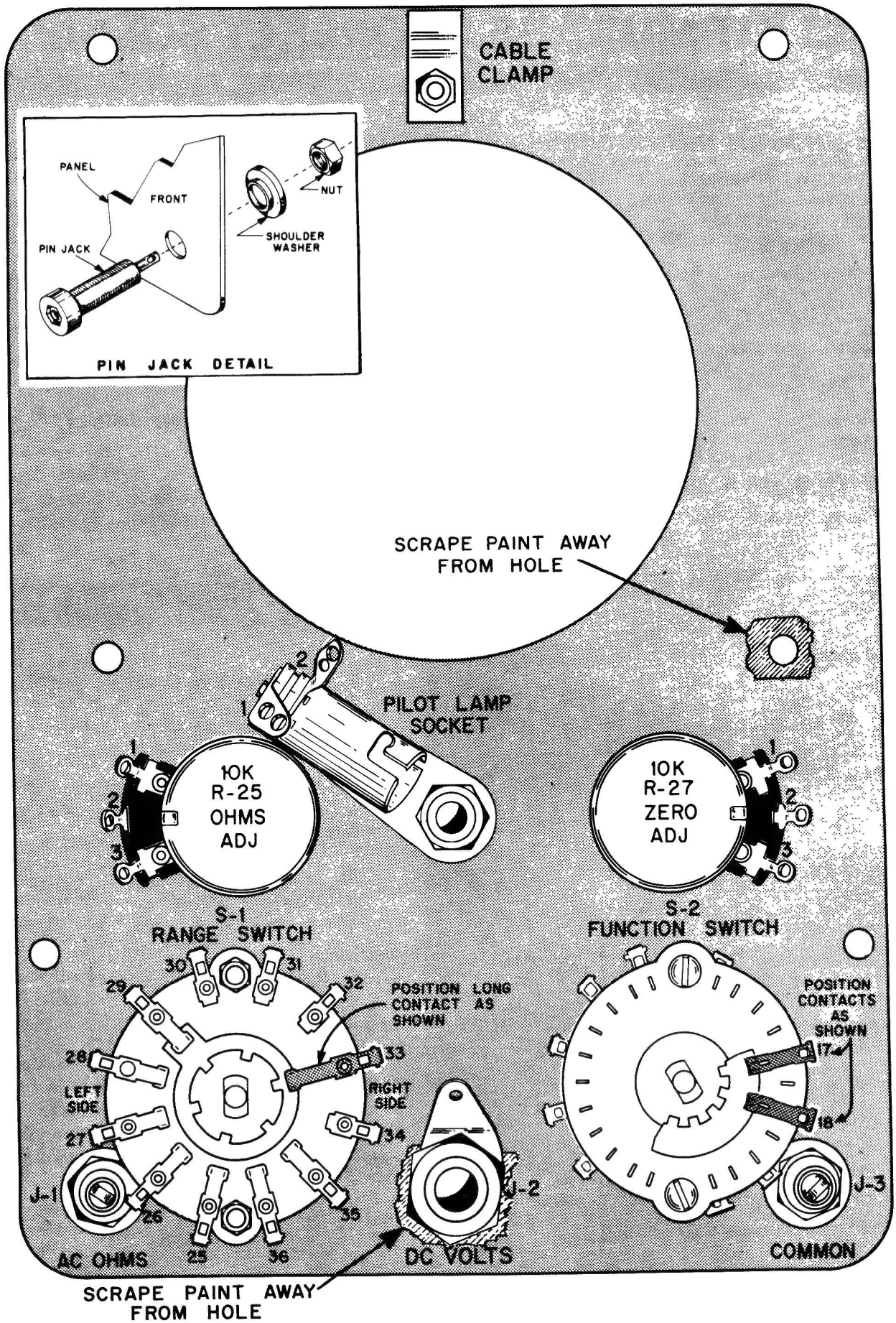

FIGURE 1. MOUNTING THE PARTS ON THE PANEL

MOUNTING THE PARTS ON THE PANEL

Before you begin mounting the parts, place a pad or a soft cloth on your work table to protect the finish on the front panel.

SEE FIGURES 1 AND 2

- () Insert the short flat head screw through the hole in the top center of the panel. Place an external lockwasher over the screw. Next put one of the cable clamps over the screw. Now, put on an internal lockwasher and tighten a nut over it very securely. See Figure 2.

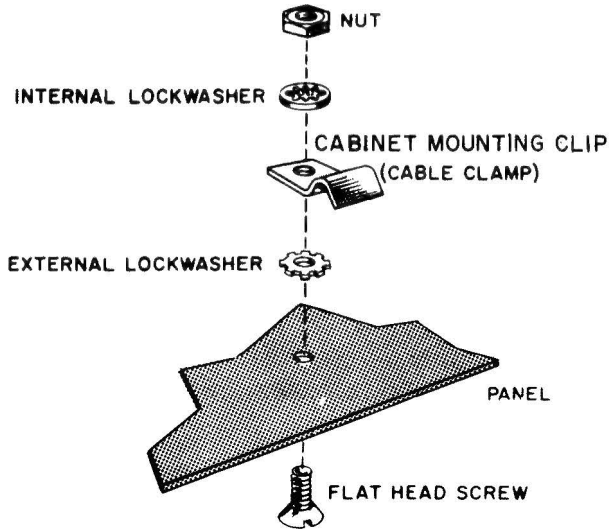

FIGURE 2. HOW TO ASSEMBLE THE CABINET CLAMP

- () Mount R-25, 10K ohms OHMS ADJUST potentiometer, in the large hole in the left center of the panel. Use two nuts to mount this control as shown in Figure 3.

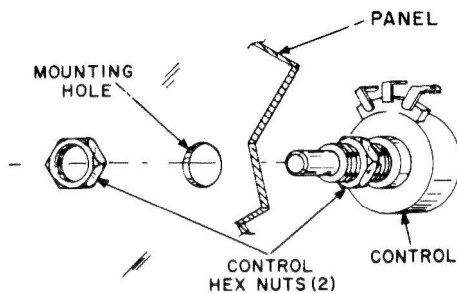

FIGURE 3. HOW TO MOUNT A CONTROL

- () Mount R-27, 10K ohm ZERO ADJUST potentiometer, in the large hole in the right center of the panel, in the same manner.
- () Mount the pilot light socket between R-25 and R-27. The bracket must be positioned as shown in Figure 1, but must not touch R-25.
- () Mount J-1, the red pin jack, in the lower left corner of the panel. Use a shouldered fiber washer on the inside of the panel to insulate the jack from the panel. Now, tighten a nut against the washer. Refer to the pin jack detail in the upper left corner of Figure 1.

- () Mount J-3, the black pin jack, in the lower right corner of the panel in the same manner.
- () Scrape the paint from the two holes as shown.
- () Mount J-2, the chassis connector in the large hole in the lower center of the panel. This connector is supplied with a shouldered fiber washer. Take this washer off and throw it away. Place the flat fiber washer over the small threaded end of the connector. Scrape the paint from around this hole on the rear of the panel. Insert the small threaded end through the hole in the panel. Place the solder lug and the flat metal washer on the connector and tighten the nut securely. See Figure 4.

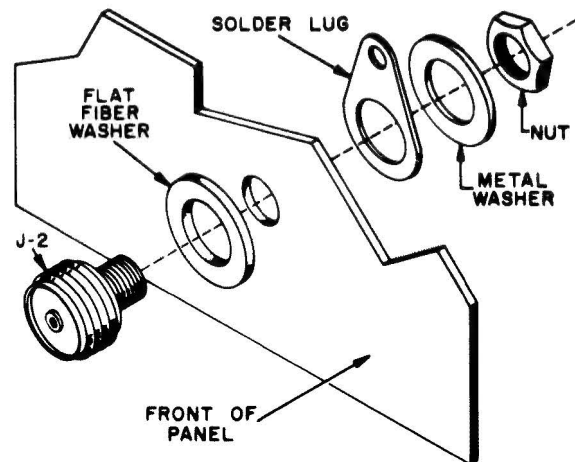

FIGURE 4. HOW TO MOUNT THE CHASSIS CONNECTOR

- () Mount S-1, the long triple wafer RANGE switch in the hole in the lower left corner of the panel. The long contact on the end wafer must be positioned as shown in Figure 1. The blank space on the wafer near the shaft end must be toward J-1. Use a large nut and a lockwasher on the inside of the panel. Fasten it securely with another large nut. Place a large knob on the shaft. Be sure the line on the knob lines up exactly with the printed dots on the panel. If not, rotate S-1 so the scale on the panel and the line on the knob correspond.
- () Mount S-2, the other triple wafer FUNCTION switch, in the other hole on the right of the panel. Use another large nut and lockwasher inside the panel. Use a large nut outside the panel. Again place a knob on the shaft and be sure that the line on the knob lines up with the scale on the panel.

You have finished mounting the parts on the panel until after the switches are wired.

WIRING AND SOLDERING HINTS

How well a piece of electronic equipment works often depends on the quality of workmanship used in its construction. It is for this reason that the following suggestions are made. These hints are mainly for the beginner, however, even experienced persons may benefit from a brief review.

The insulated wire furnished with this kit is cut to length and the ends are stripped. Each different colored wire is a different length, therefore, be sure to use the color specified in each of the wiring steps.

A long piece of bare wire is included. Whenever it is necessary to use some of it, the exact length of the piece required is given.

The flexible tubing supplied is called "spaghetti". Spaghetti is used to cover the bare end leads of some of the components and portions of some of the bare wires when there is danger they will touch other bare wires or the chassis.

The proper way to connect a wire or lead to a solder terminal is shown in Figure 5. To insure a good mechanical connection, squeeze the wire against the terminal with your long nose pliers after it has been hooked on. Make sure the wires, leads, and terminals are clean before connecting them. If necessary, scrape them with a pocket knife until any foreign substance, such as wax, is removed. Be extremely careful not to nick the wire with the knife, or it may break when it is bent.

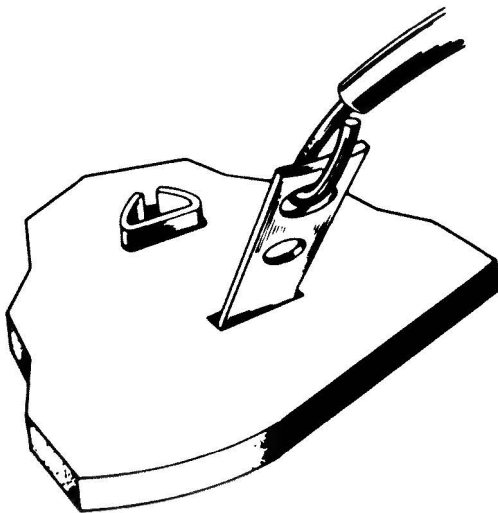

FIGURE 5. HOW TO CONNECT A WIRE TO A TERMINAL

Unless otherwise stated, all the leads on the resistors, capacitors, and transformer should be as short as possible. Figure 6 illustrates the best way to connect a component. As shown, the end leads should be pulled through the terminals so that the parts are tightly mounted. After a lead is pulled through a terminal, bend it around the terminal and cut off the excess wire.

USE ONLY ROSIN CORE SOLDER

KITS WIRED WITH ACID CORE SOLDER OR PASTE FLUX WILL CORRODE AND WILL NOT WORK LONG. SUCH KITS ARE NOT ELIGIBLE FOR REPAIR OR SERVICE. DO NOT USE A SAL AMMONIAC BLOCK TO CLEAN YOUR IRON. IT IS VERY CORROSIVE.

Before soldering, the tip of your soldering iron must be properly tinned. To do this, clean the surfaces of the tip with steel wool, or a fine file, until the bright copper surface is exposed. Plug the iron in and allow it to heat until it melts solder. Apply solder to the tip until it is well covered with a thin coat. Wipe off the excess solder with a rag. The tip should now be "shiny". Re-tin the tip whenever it becomes covered with a layer of scale (flakes of gray matter).

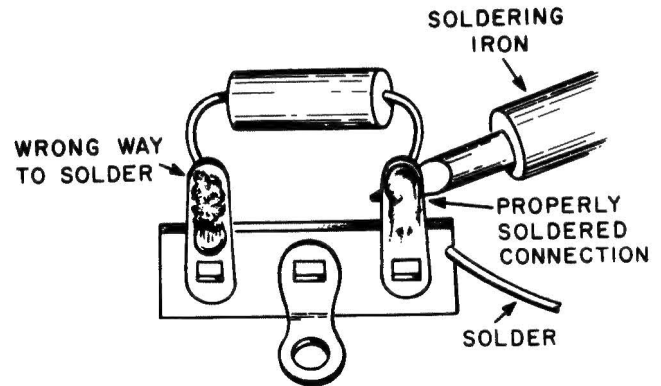

FIGURE 6. THE BEST WAY TO CONNECT A COMPONENT

Before soldering a connection be sure the iron is hot enough to melt solder. Preheat the CONNECTION by holding the tip of the iron against the joint to be soldered. After the joint is heated, apply solder between the connection and the iron tip. Use only enough solder to fill the crevices and cover all of the wires and the terminal. Do not solder any connection until all wires have been connected to it.

After you have soldered a connection, push any insulation or spaghetti as close to the connection as possible. This will prevent close connections from touching one another and causing a short.

When wiring the contacts of the switches, be careful not to bend the switch contacts which will reduce the spring pressure of the contacts. If the flux runs out around the contacts, it will cause a leakage path.

The precision resistors furnished with your VTVM are sensitive to heat. When you make a solder connection close to the body of one of these resistors, hold the lead with the long nose pliers between the body and the connection to be soldered. The jaws of the pliers will conduct the heat away from the body of the resistor.

You are now ready to begin wiring your KNIGHT VTVM. As you are wiring, we would like you to keep the following in mind: Do your best to position the parts as shown in the wiring diagrams, and, above all, USE ONLY ROSIN CORE SOLDER.

WIRING SWITCH S-1

S-1 is the three wafer switch in the lower left corner of the panel. The open space between two of the terminals, on the wafer nearer the shaft end, is used as the reference point for numbering the terminals.

SEE FIGURE 7.

CAUTION: The precision resistors mounted on the range switch S-1 must not touch each other, nearby terminals or the metal frame of the switch. These resistor bodies are not insulated, so the resistors must be handled very carefully. When you mount these resistors, keep the leads short, as shown in the illustration. Clip off excess lead lengths.

- () Connect, but do not solder, one end of R-2, 280K ohm resistor, to terminal 1 of S-1. Connect, but do not solder, the other end to terminal 4 of S-1. Position R-2 as shown in Figure 7.
- () Connect, but do not solder, one end of R-3, 900K ohm, 1 watt, resistor, to terminal 1. Connect, but do not solder, the other end to terminal 6. Position R-3 as shown in Figure 7.
- () Solder one end of a 2 inch bare wire to terminal 1. Insert the other end through a 1 1/4 inch length of spaghetti. Solder it to terminal 5.
- () Solder one end of R-1, 130K ohm resistor, to terminal 4. Connect, but do not solder, the other end to terminal 13.

- () Connect, but do not solder, one end of R-16, 10K ohm resistor, to terminal 13. Insert the other end through a 1/2 inch length of spaghetti. Connect, but do not solder, it to terminal 17.
- () Connect, but do not solder, one end of R-20, 90K ohm resistor, to terminal 14. Connect, but do not solder, the other end to terminal 25.
- () Connect, but do not solder, one end of a 2 inch bare wire to terminal 14. Solder the other end to terminal 26.
- () Solder one end of R-21, 9K ohm resistor to terminal 14. Connect, but do not solder, the other end to terminal 27.
- () Connect, but do not solder, one end of R-22, 900 ohm resistor, to terminal 16. Solder the other end to terminal 27.
- () Connect, but do not solder, one end of a 2 inch bare wire to terminal 16. Solder the other end to terminal 28.
- () Solder one end of R-23, 90 ohm resistor, to terminal 16. Connect, but do not solder, the other end to terminal 29.

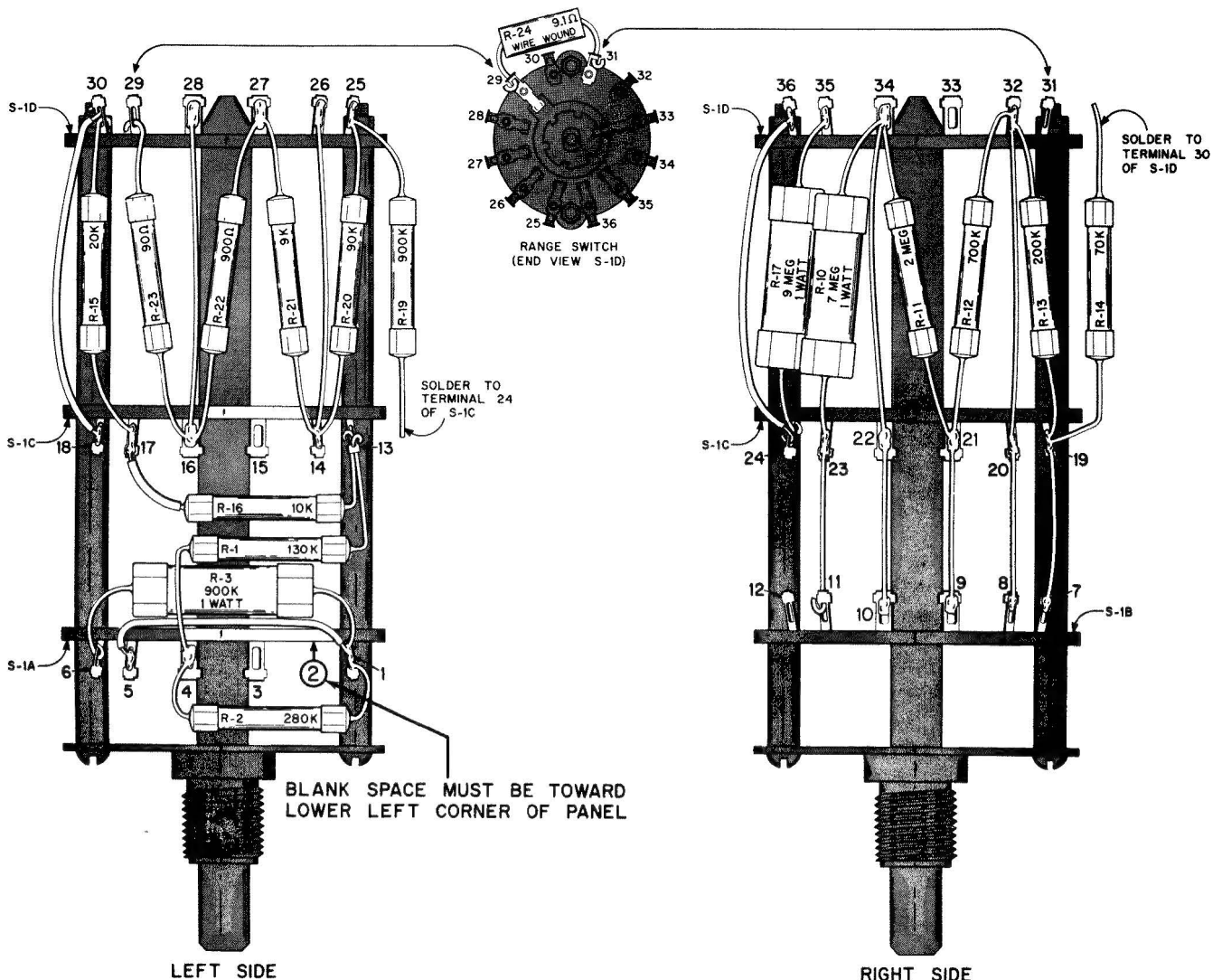

FIGURE 7. HOW TO WIRE THE RANGE SWITCH

FIGURE 8. HOW TO WIRE THE PANEL

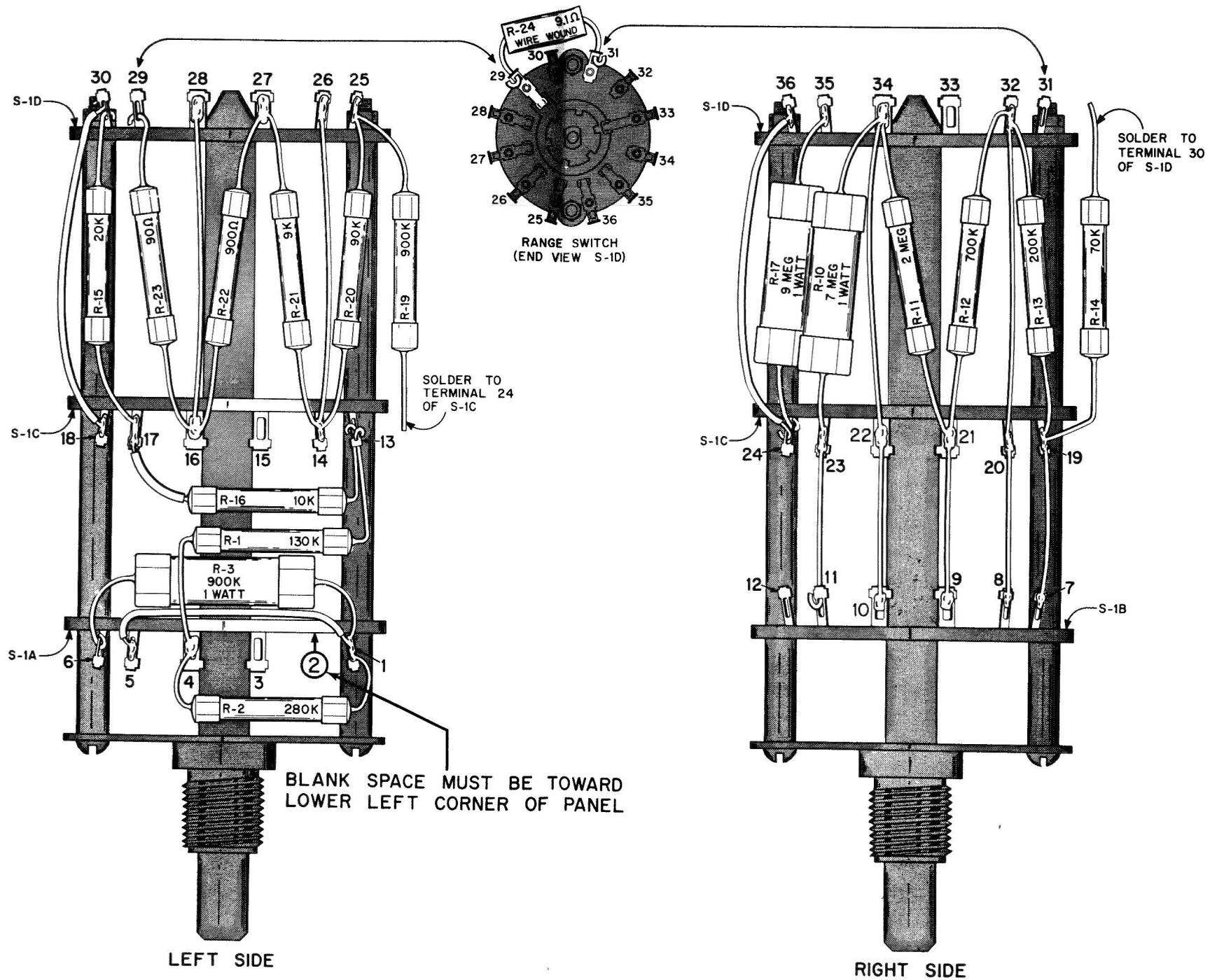
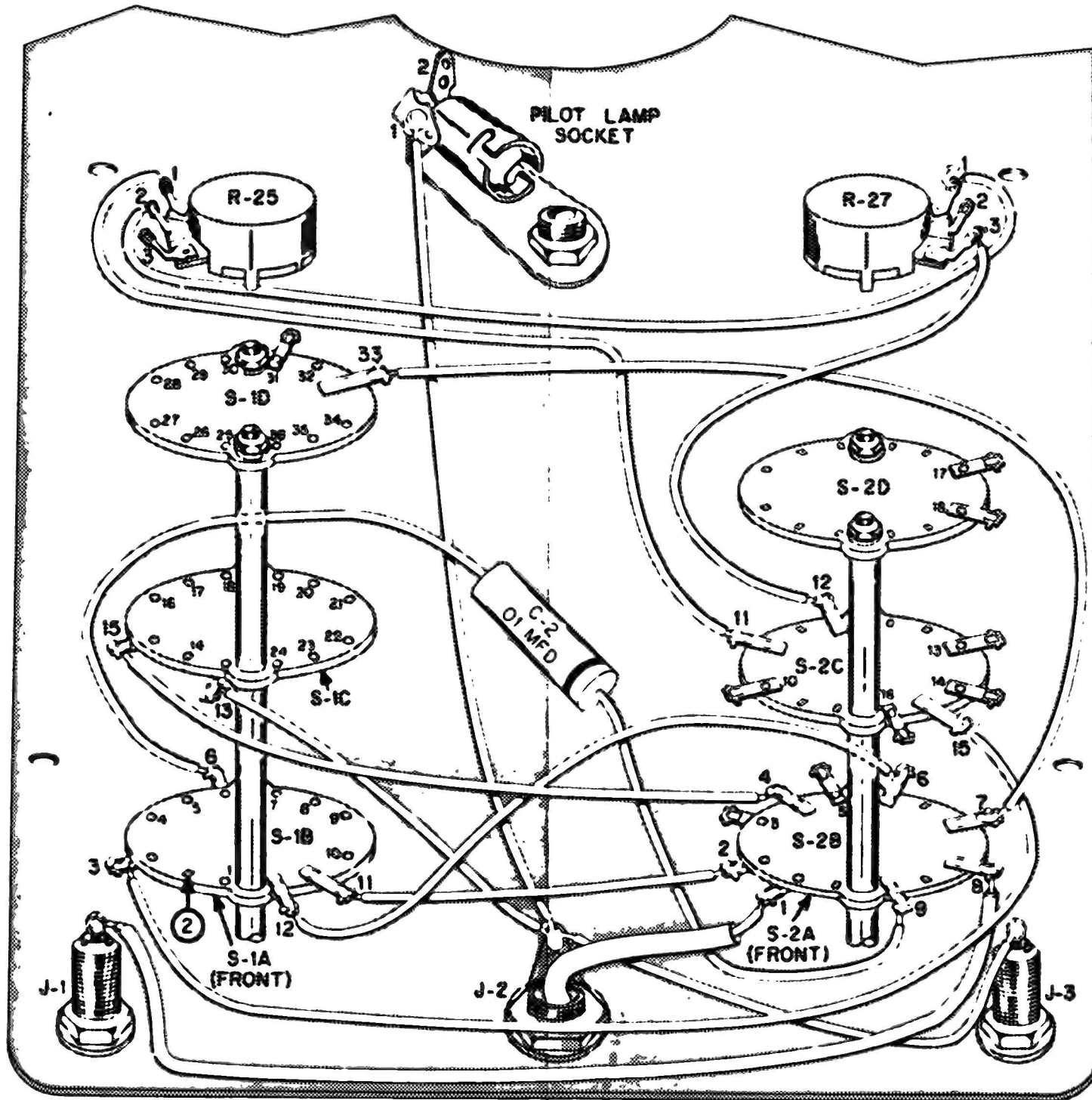

FIGURE 7. HOW TO WIRE THE RANGE SWITCH

NOTE

SWITCHES ARE SHOWN
EXPANDED AND SIMPLIFIED



- () Solder one end of R-15, 20K ohm resistor, to terminal 17. Connect, but do not solder, the other end to terminal 30.
- () Solder one end of a 2 inch red wire to terminal 18. Connect, but do not solder, the other end to terminal 30.
- () Pass one end of R-14, 70K ohm resistor through terminal 19 and connect it to terminal 7. Solder terminal 7, but do not solder terminal 19. Solder the other end of R-14 to terminal 30.
- () Solder one end of R-13, 200K ohm resistor, to terminal 19. Connect, but do not solder, the other end to terminal 32.
- () Pass one end of a 3 inch bare wire through terminal 20 and connect it to terminal 8. Solder both terminals 8 and 20. Connect, but do not solder, the other end to terminal 32.
- () Connect, but do not solder, one end of R-12, 700K ohm resistor, to terminal 21. Solder the other end to terminal 32.
- () Pass one end of R-11, 2 Megohm resistor, through terminal 21 and connect it to terminal 9. Solder both connections. Connect, but do not solder, the other end to terminal 34.
- () Pass one end of a 3 inch bare wire through terminal 22 and connect it to terminal 10. Solder both connections. Connect, but do not solder, the other end to terminal 34.
- () Pass one end of R-10, 7 Megohm, 1 watt, resistor, through terminal 23, and connect it to terminal 11. Solder terminal 23, but do not solder terminal 11. Solder the other end to terminal 34.
- () Connect, but do not solder, one end of R-17, 9 Megohm, 1 watt resistor, to terminal 24. Solder the other end to terminal 35.
- () Connect, but do not solder, one end of a red wire to terminal 24. Solder the other end to terminal 36.
- () Solder one end of R-19, 900K ohm resistor, to terminal 24. Solder the other end to terminal 25.
- () Solder one end of R-24, the 9.1 ohm wirewound resistor marked with the color bands white, brown, gold, and gold, to terminal 29. Connect, but do not solder, the other end to terminal 31.
- () Solder one end of another orange wire to the terminal on J-3, the common jack. Solder the other end to the solder lug.
- () Pass one end of a red wire through the chassis connector. Solder it to the eyelet in the center of the connector. Insert the other end through a 1½ inch length of the large spaghetti. Force the spaghetti down against the soldered eyelet connection. Solder the other end of the red wire to terminal 1 of S-2.
- () Insert each end lead of C-2, .01 MFD paper capacitor, through a 1½ inch length of small spaghetti. Solder the lead from the banded end to terminal 9 of S-2. Solder the other lead to terminal 6 of S-1. Position C-2 between J-2 and S-2A.
- () Solder one end of a red wire to terminal 11 of S-1. Solder the other end to terminal 2 of S-2.
- () Solder one end of a yellow wire to terminal 12 of S-1. Solder the other end to terminal 6 of S-2.
- () Insert a green wire through a 4½ inch length of the large spaghetti. Solder one end to J-1. Solder the other end to terminal 8 of S-2.
- () Solder one end of a green wire to terminal 3 of S-1. Connect, but do not solder, the other end to terminal 15 of S-2.
- () Solder one end of a yellow wire to terminal 1 of R-25. Solder the other end to terminal 11 of S-2.
- () Solder one end of a blue wire to terminal 2 of R-25. Connect, but do not solder, the other end to terminal 1 of R-27.
- () Solder one end of a green wire to terminal 33 of S-1. Solder the other end to terminal 7 of S-2.
- () Solder one end of a red wire to terminal 12 of S-2. Connect, but do not solder, the other end to terminal 3 of R-27.
- () Solder one end of a green wire to terminal 15 of S-1. Solder the other end to terminal 4 of S-2.

SEE FIGURE 9.

- () Be sure the paint is scraped from around the lower right meter mounting hole on the rear of the panel.
- () Insert the two 6-32 x 2" screws through the holes in the panel where shown. These screws are held in place by the meter which is mounted in the next step.
- () Mount the meter from the front of the panel over the heads of the two screws set in the panel. Tighten one of the nuts supplied with the meter over each of the two top screws and the lower left screw. Do not tighten them too securely. Place an internal tooth lockwasher and the other cable clamp over the lower right screw. Now, tighten a nut over the screw. The other four nuts supplied with the meter are used to mount the printed circuit board.

NOTE: If the meter was supplied with a shorting wire between the meter terminals, remove this wire.

You have finished mounting the precision resistors. **VERY CAREFULLY CHECK EACH CONNECTION MADE ON S-1.** Compare your completed switch with Figure 7. *A single error here will keep your kit from operating properly.*

HOW TO WIRE THE PANEL

SEE FIGURE 8.

- () Solder one end of a green wire to terminal 1 on the pilot light socket. Connect, but do not solder, the other end to the solder lug under the chassis connector nut.
- () Solder one end of an orange wire to terminal 13 on S-1. Connect, but do not solder, the other end to the solder lug.

- () Solder one end of a blue wire to terminal 14 of S-2. Solder the other end to the solder lug on the negative meter post.
- () Solder one end of a violet wire to terminal 10 of S-2. Solder the other end to the solder lug on

the positive meter post.

- () Solder one end of another violet wire to terminal 2 of the pilot light socket. The other end will be connected to the printed circuit later.
- () Insert the pilot lamp into its socket.

NOTE

SWITCHES ARE SHOWN EXPANDED AND SIMPLIFIED. THEREFORE, WIRE LENGTHS APPEAR LONGER THAN ACTUAL SIZE.

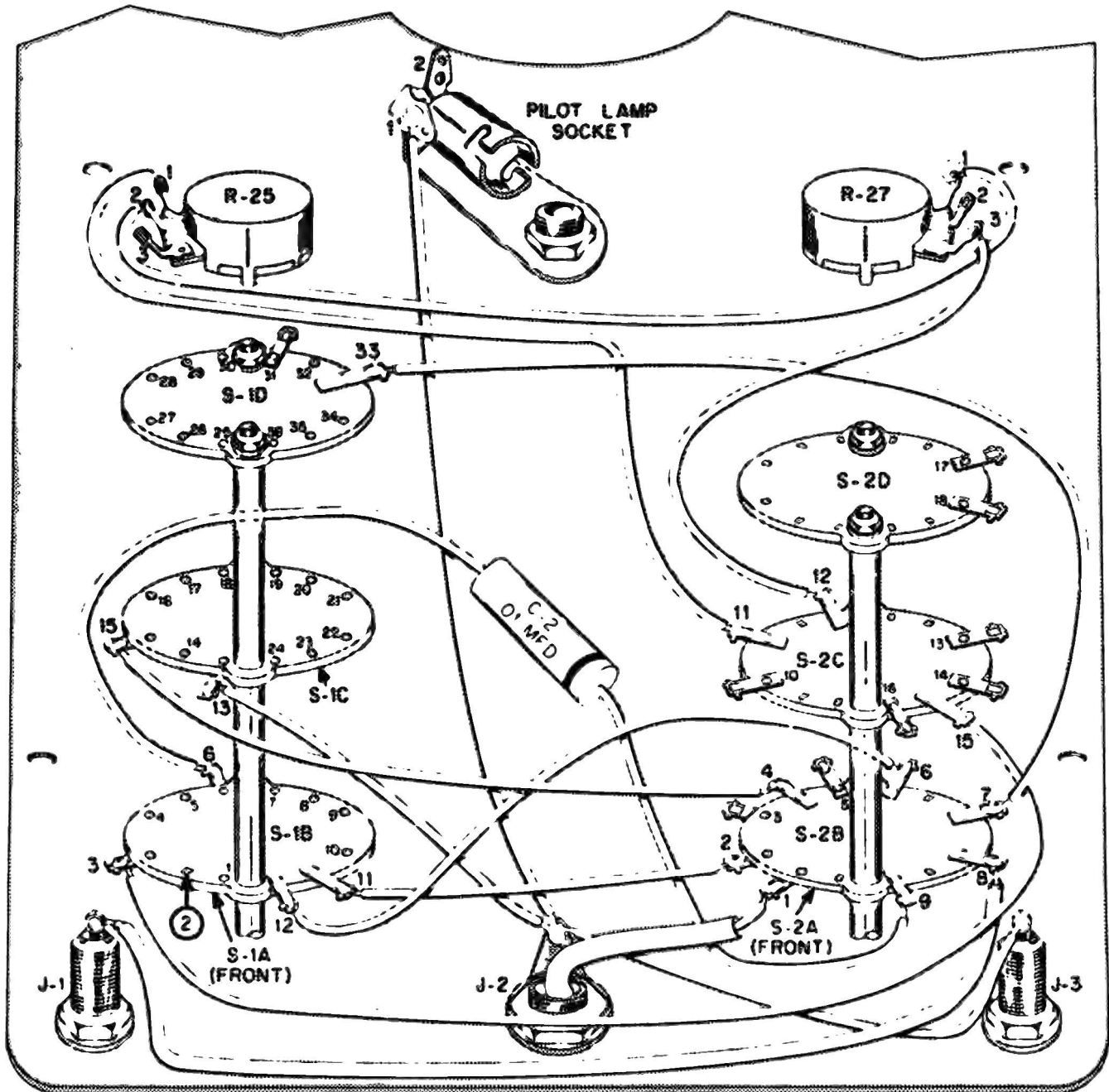

FIGURE 8. HOW TO WIRE THE PANEL

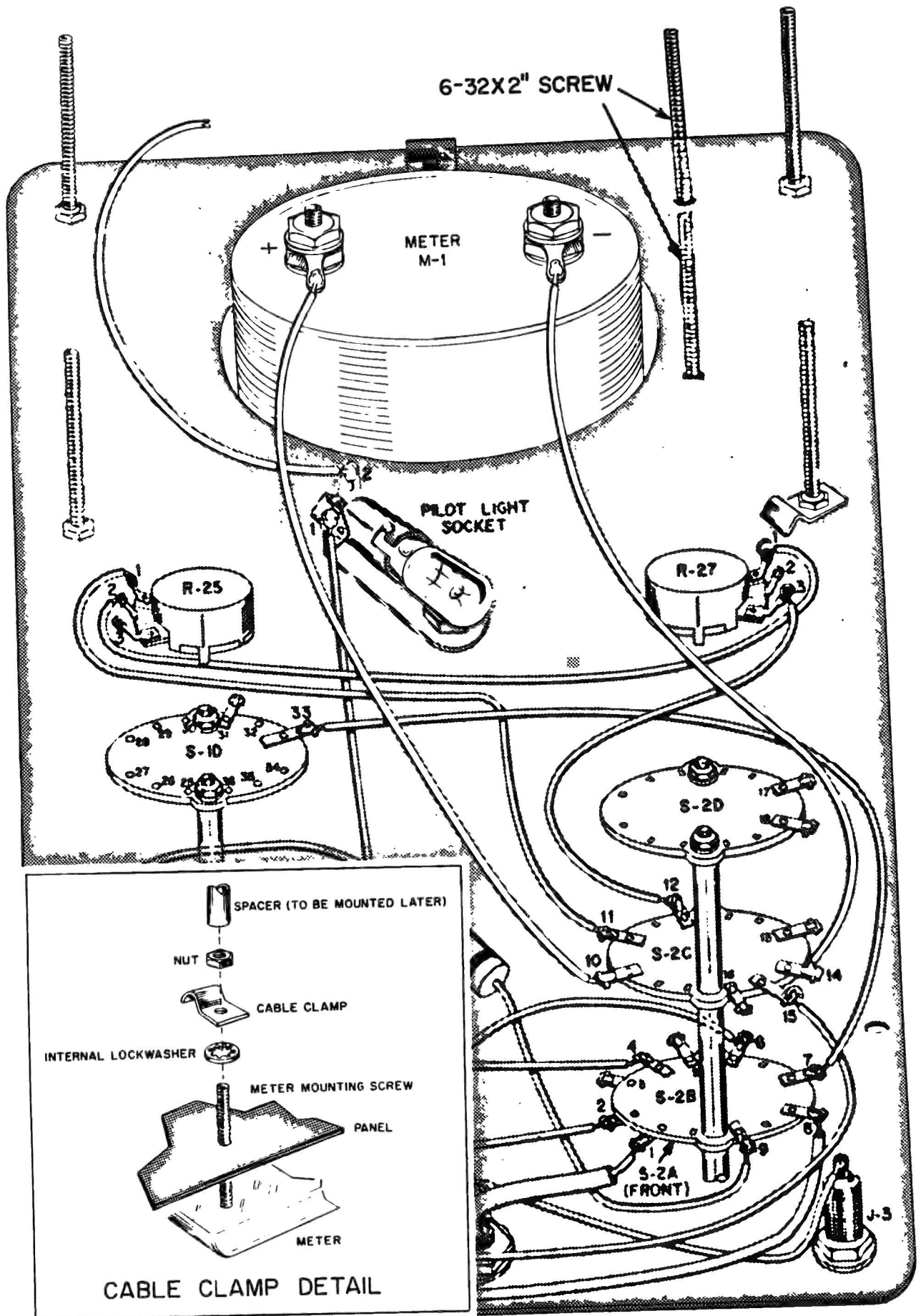

FIGURE 9. HOW TO MOUNT AND WIRE THE METER

ASSEMBLING THE PRINTED CIRCUIT BOARD

You are ready to mount the parts on the printed circuit board. Examine it. One side shows the outline and value of each part to be mounted. That is, the capacitors, resistors, the transformer, the battery, etc., are pictured in their exact location.

The following procedure assures well soldered connections on the printed circuit board. Study it.

1. **INSERT** the wire leads of the parts through the holes as shown in Figure 11.
2. **BEND LEADS FLAT** against the foil side of the board so the part is held securely in place.
3. **SOLDER EACH LEAD** of each part (after all parts are mounted) right at the hole in the metal foil where the lead comes through. Be sure you heat the connection until the solder runs and spreads.
4. **CUT OFF EACH LEAD** as close as possible to the board. Inspect each lead after cutting it off to be sure it does not short across the bakelite from one foil conductor to another. This would cause a short and your VTVM won't work.

If a soldered connection should have a dull appearance it is not a good solder connection. Using more solder, again solder the connection. Do not use so much solder that it runs off the printed foil wiring onto the board and touches another foil conductor. This may cause an intermittent or a short between connection points.

Before you solder the tabs of the tube sockets to the metal foil, insert the tubes in the sockets. When you solder the tabs of the tube sockets to the metal foil, heat the tube socket tab until the solder runs down onto the metal foil and spreads.

After you have soldered all the connections on the printed circuit board, but before you put in the cable, examine the metal foil side of the board carefully. Again be sure no solder or cut-off lead touches any foil conductor except the one to which it is soldered. Also, be sure the tabs of the controls have not been bent so much that they touch any other conductor. If the flux from the solder has run out around the connections that is all right. The flux is not conductive.

SEE FIGURE 11.

- () Mount the 9-pin miniature socket for V-2, the 12AU7, from the screened side of the board. This socket can be mounted only one way. Line up the notch in the socket with the half-moon shaped notch in the board. Put the 12AU7 in the socket. Solder one end of a 1 inch bare wire to pin 1. Solder the other end to pin 6. The wire must not touch the bottom of the socket. Solder all pins to the board. See Figure 10.
- () Mount the 7-pin miniature socket for V-1, the 6AL5. Put the 6AL5 in the socket. Solder all pins. Then remove both tubes and place them back in their boxes.
- () Mount R-34, 10,000 ohms AC Balance potentiometer, from the screened side of the board. The three terminals must be toward the left edge of the board. Bend the two large, flat terminals out slightly so the potentiometer is held firmly. Do not bend either flat terminal so much that it touches another foil conductor.

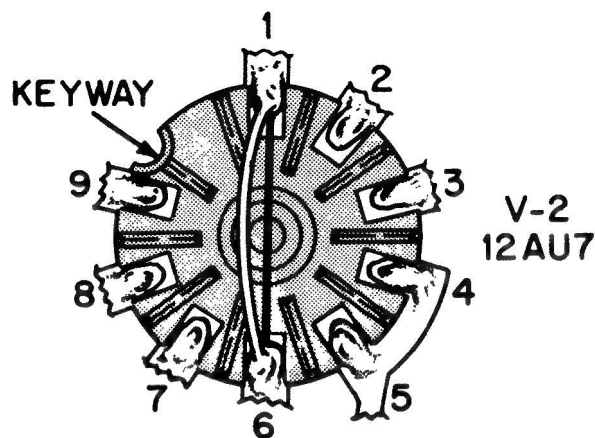

NOTE:- DO NOT ALLOW JUMPER WIRE TO TOUCH BOTTOM OF SOCKET.

FIGURE 10. JUMPER WIRING ON V-2.

Solder each terminal and also the two large flat terminals.

- () Mount R-29, 10,000 ohms DC Calibration potentiometer in the same manner. Solder the large flat terminals and the two small terminals.
- () Mount R-26, 10,000 ohms AC Calibration potentiometer in the same manner with the three terminals toward the terminals of R-29. Solder the three terminals which go into the printed wiring.
- () Mount CR-1, the rectifier, by inserting the two terminals through the holes in the upper left corner of the board. The positive side must be toward the right. Bend the two terminals slightly to hold CR-1 firmly. Solder both terminals.
- () Mount C-6, the 20 MFD, 200V electrolytic filter capacitor, with the "+" end next to the rectifier. Solder both leads.

SEE FIGURES 11 AND 12.

- () Mount the battery bracket as shown in Figure 12. Insert the 6-32 x 5/16" machine screw through the battery retaining clip through the center hole in the battery bracket, through a flat fiber washer, and through the hole in the printed circuit board. Tighten a nut onto the screw. Use the thin screw through the hole in the end of the bracket near T-1, and through the circuit board. Place a small flat metal washer over the screw on the printed circuit wiring side of the board and tighten a nut over the screw.

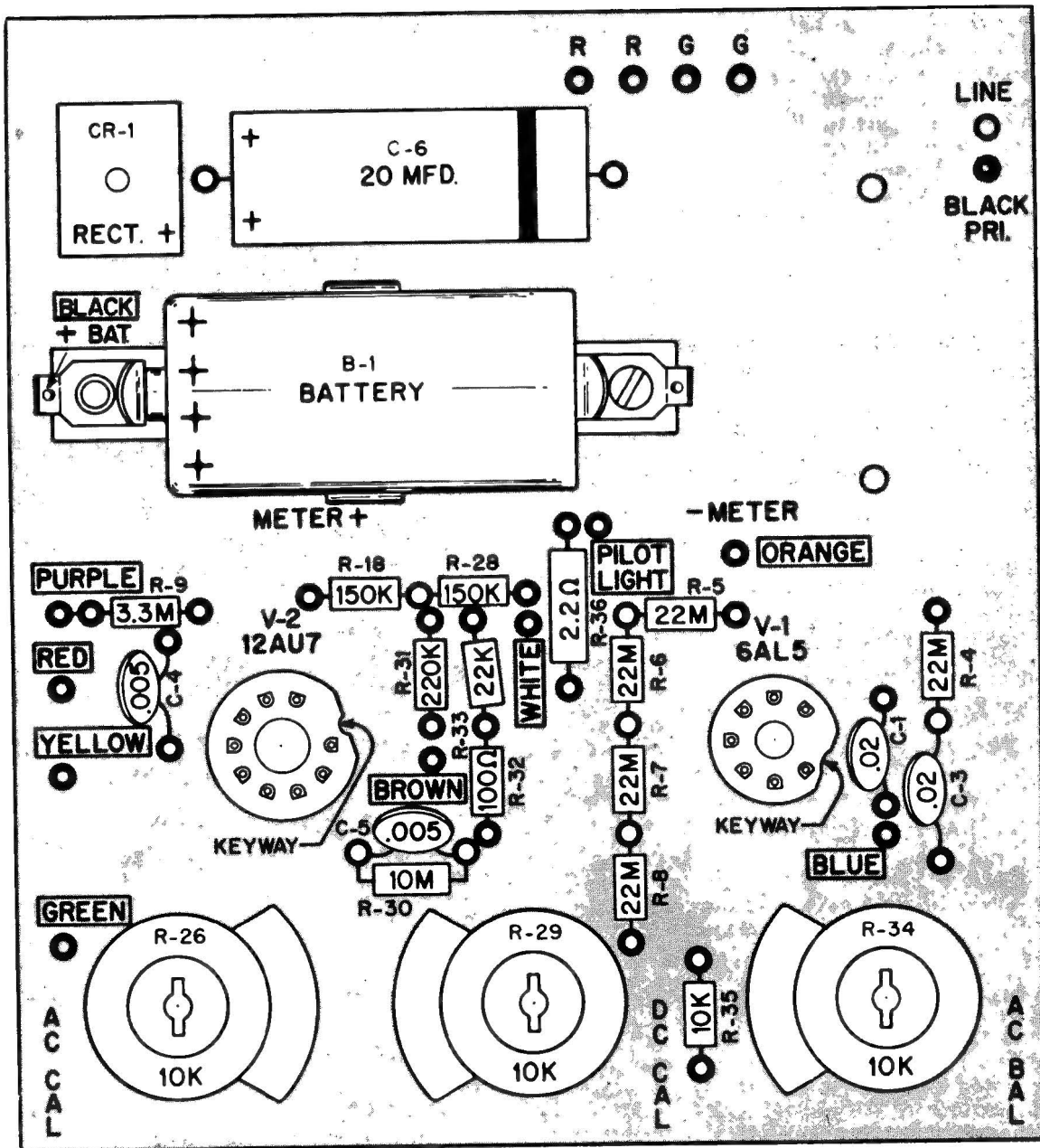
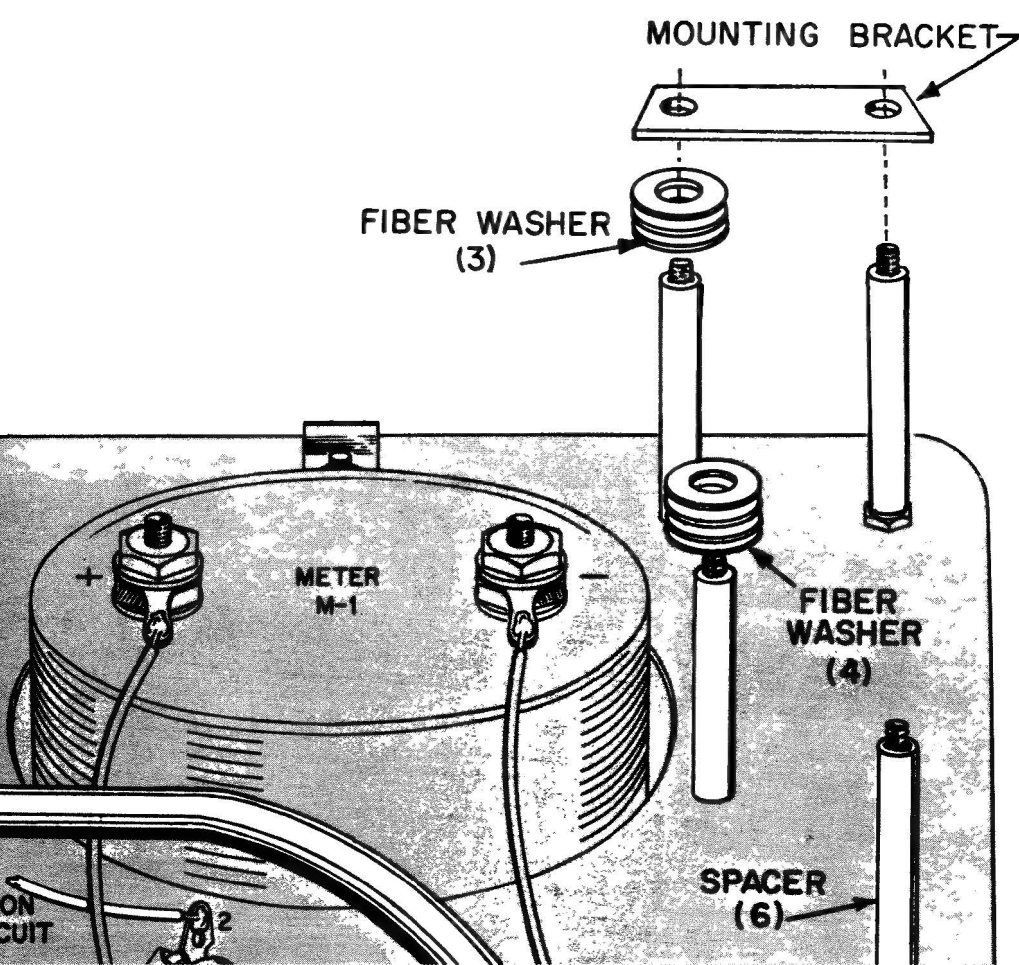
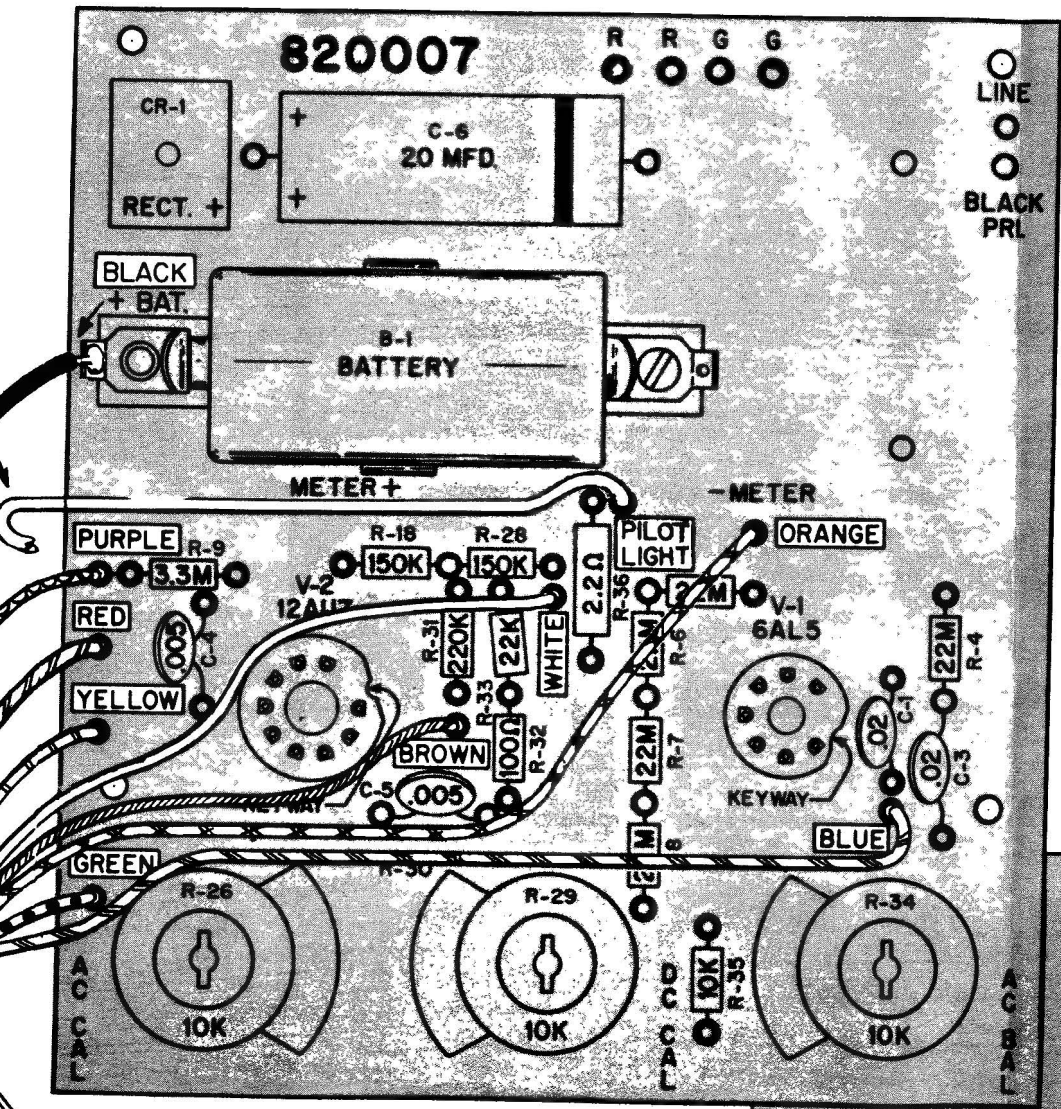

FIGURE 11. MOUNTING THE PARTS ON THE PRINTED CIRCUIT BOARD

You are now ready to mount the resistors and capacitors on the printed circuit board.

- () Mount R-9, 3.3 Megohm resistor (orange, orange, green) as shown in Figure 11.
- () Mount C-4, .005 MFD disc capacitor.
- () Mount R-18, 150K ohm resistor (brown, green, yellow).
- () Mount R-28, 150K ohm resistor (brown, green, yellow).
- () Mount R-33, 22K ohm resistor (red, red, orange).
- () Mount R-31, 220K ohm resistor (red, red, yellow).
- () Mount R-32, 100 ohm resistor (brown, black, brown).
- () Mount C-5, .005 MFD disc capacitor.
- () Mount R-30, 10 Megohm resistor (brown, black, blue).
- () Mount R-36, 2.2 ohm resistor (red, red, gold, gold).
- () Mount R-5, 22 Megohm resistor (red, red, blue).
- () Mount R-6, 22 Megohm resistor (red, red, blue).
- () Mount R-7, 22 Megohm resistor (red, red, blue).
- () Mount R-8, 22 Megohm resistor (red, red, blue).
- () Mount R-35, 10K ohm resistor (brown, black, orange).
- () Mount C-1, .02 MFD disc capacitor.
- () Mount R-4, 22 Megohm resistor (red, red, blue).



KNIGHT VTVM

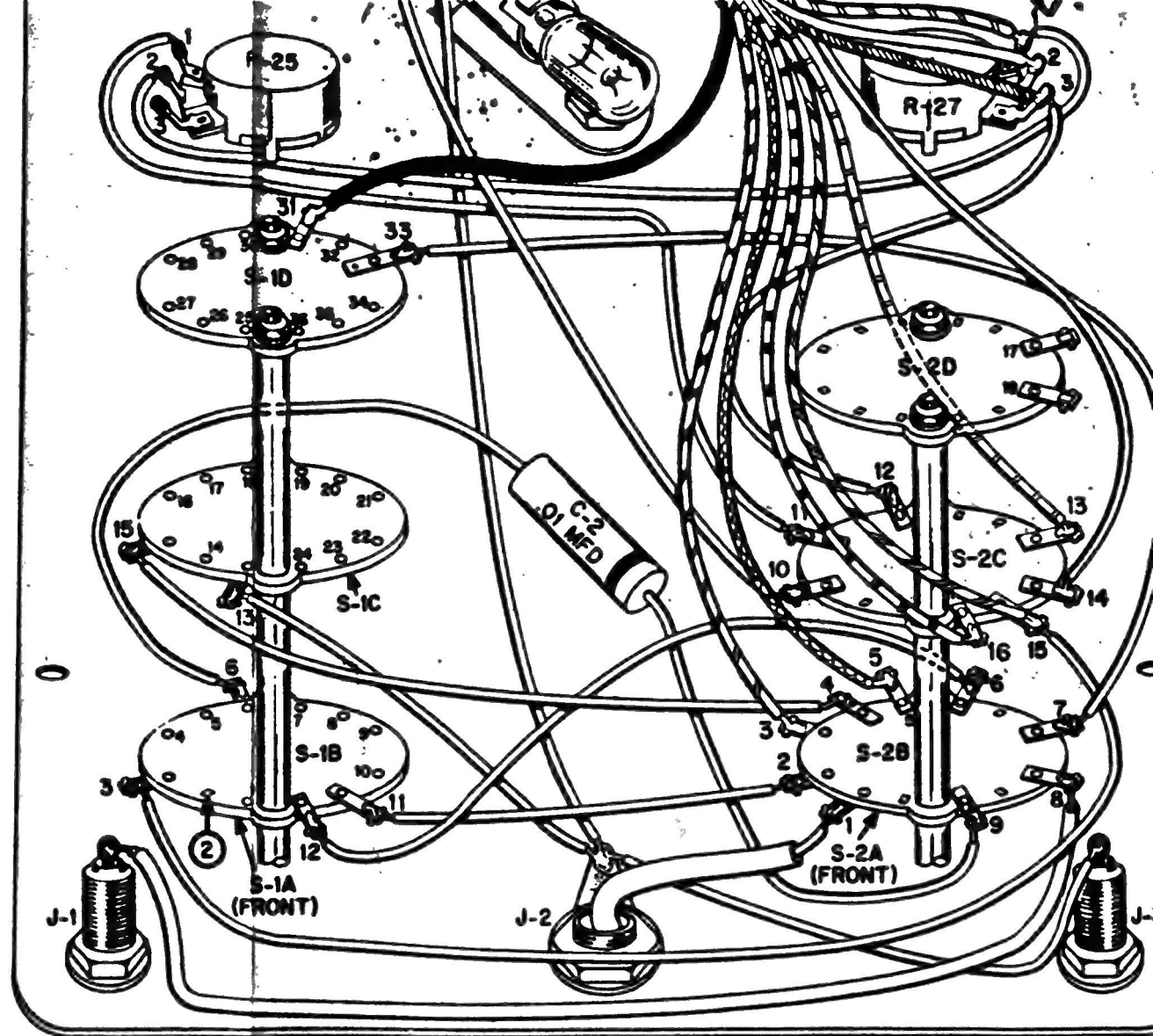

FIGURE 13. CONNECTING THE CABLE

- () Mount C-3, .02 MFD disc capacitor. Note that the leads of this capacitor must be positioned so that they clear the hole for mounting the printed circuit to the panel.
- () Turn the circuit board over and solder each connection. Remember to use a small iron and the rosin-core solder supplied. Be sure the connection where R-18, R-28, and R-31 join is well soldered. Cut off each end lead close to the soldered connection.

FINAL WIRING

You are now ready to prepare the cable and do the final wiring on your VTVM.

SEE FIGURE 13.

- () Carefully remove $4\frac{1}{2}$ inches of the outer insulation from one end of the cable. Be very careful not to cut the insulation of any of the wires. Now, trim the wires to the following lengths:

Orange:	Leave it the full $4\frac{1}{2}$ inches.
Green:	1"
Yellow:	1"
Red:	$1\frac{1}{2}$ "
Violet:	$1\frac{3}{4}$ "
Black:	$2\frac{3}{4}$ "
Brown:	$2\frac{1}{4}$ "
White:	$3\frac{1}{2}$ "
Blue:	$4\frac{1}{4}$ "

Remove $\frac{1}{4}$ inch of insulation from the end of each wire. Coat each end with solder.

- () Solder the black wire to the terminal on the battery bracket marked + Bat. This wire does not go through the printed circuit board.
- () Insert each of the other wires into the hole in the board marked with the corresponding color. Solder each on the printed wiring side of the board.
- () Remove $3\frac{3}{4}$ " of the outer insulation from the other end of the cable. Trim each wire as follows:

Red:	Leave it the full $3\frac{3}{4}$ "
White:	$2\frac{3}{4}$ "
Brown:	$2\frac{1}{2}$ "
Violet:	$1\frac{1}{2}$ "
Yellow:	$2\frac{3}{4}$ "
Blue:	3"
Green:	$3\frac{3}{4}$ "
Orange:	2"
Black:	3"

Remove $\frac{1}{4}$ " of insulation from the end of each wire. Coat each end with solder.

- () Solder the violet wire to terminal 5 of S-2.
- () Solder the brown wire to terminal 3 of R-27.
- () Solder the white wire to terminal 2 of R-27.
- () Solder the red wire to terminal 1 of R-27.
- () Solder the yellow wire to terminal 13 of S-2.

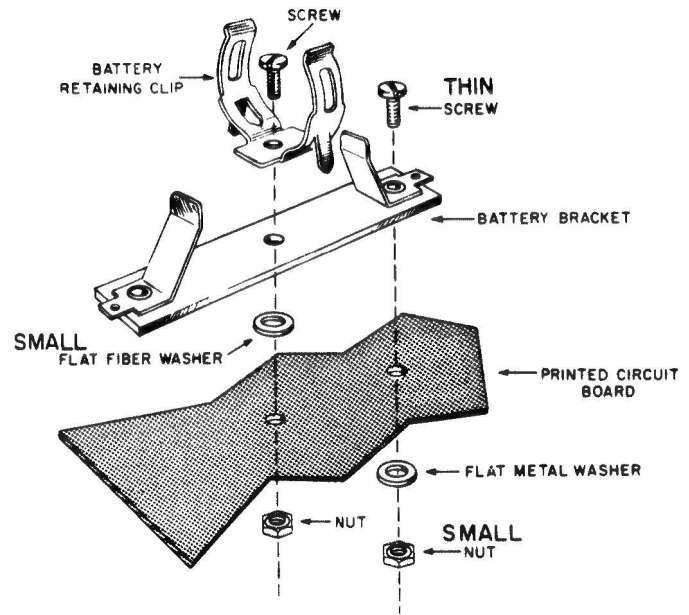

- () Solder the blue wire to terminal 15 of S-2.
- () Solder the green wire to terminal 16 of S-2.
- () Solder the orange wire to terminal 3 of S-2.
- () Solder the black wire to terminal 31 of S-1.
- () Solder the violet wire from terminal 2 of the pilot light socket to PILOT LIGHT on the printed circuit board. Bring this wire over the screened side of the board.
- () Put one of the spacers over each of the six mounting screws.
- () Place three of the large fiber washers over the screw shown.
- () Place the mounting bracket over this screw and the top right meter mounting screw.
- () Place four of the large fiber washers over the screw shown.

SEE FIGURE 14

- () The printed circuit board will be mounted on six mounting screws. First place a large fiber washer on the single screw in the corner of the panel (upper left corner in Figure 14). Then mount the board on the six screws. Place another large fiber washer on top of the board, over the same corner screw. Secure the board with a split washer and nut on each of the four screws, as shown in Figure 14.
- () Trim the leads of T-1, the power transformer to the following lengths:
 - The black lead toward the top right corner to $1\frac{1}{2}$ ".
 - The other black lead to 6".
 - Both green leads to $1\frac{1}{2}$ ".
 - Both red leads to 2".

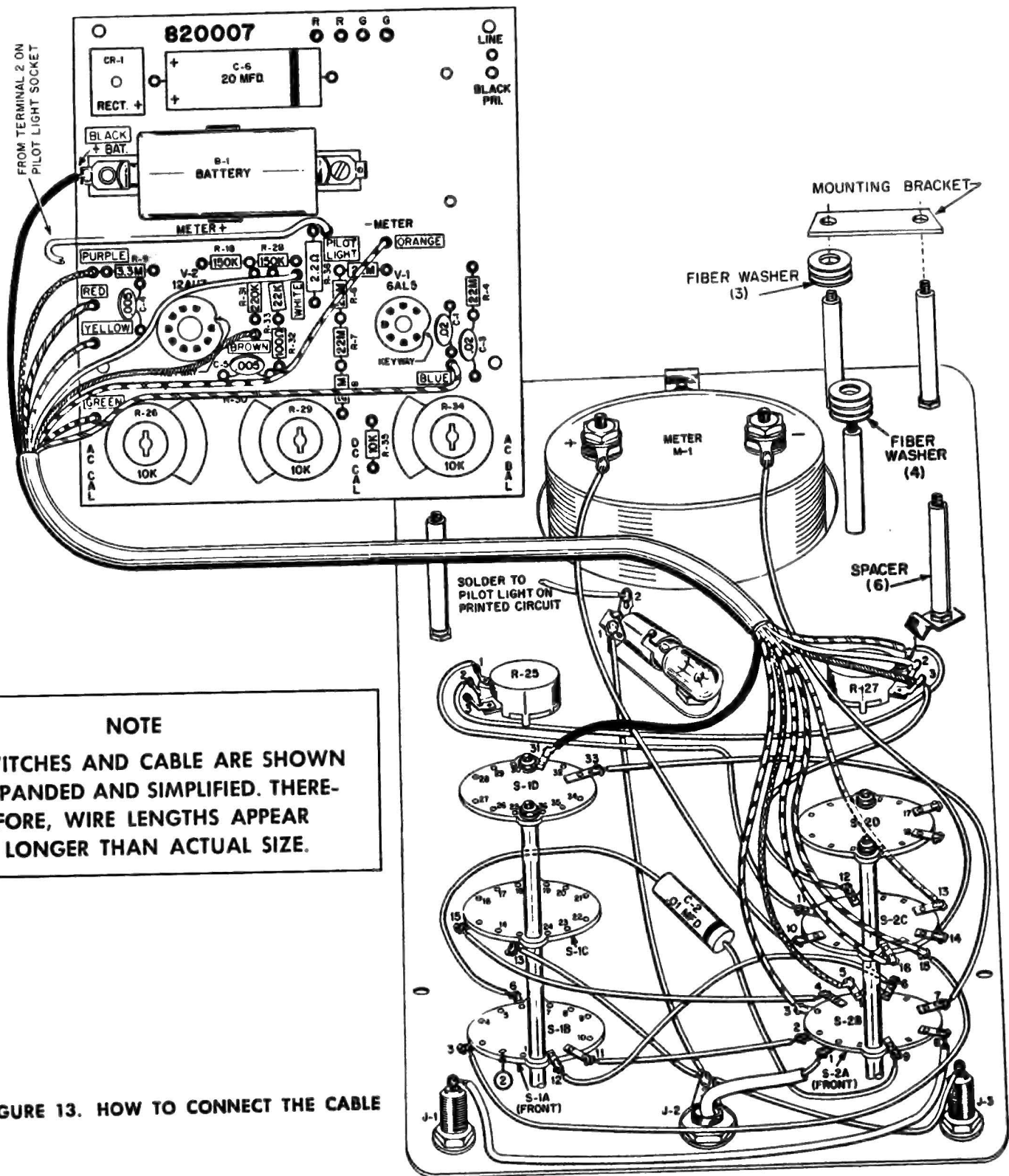

NOTE
 SWITCHES AND CABLE ARE SHOWN
 EXPANDED AND SIMPLIFIED. THERE-
 FORE, WIRE LENGTHS APPEAR
 LONGER THAN ACTUAL SIZE.

FIGURE 13. HOW TO CONNECT THE CABLE

Remove the insulation from $\frac{1}{4}$ " of the end of each lead. Hold the lead with pliers close to the transformer as you remove the insulation. Coat the stripped end of each lead with solder.

- () Mount T-1 on the remaining two mounting screws, with the leads positioned as shown. Place three large fiber washers under the mounting tab shown and fasten the transformer with two split washers and nuts.
- () Connect the leads of T-1 as follows:
 Solder the short black lead in the hole marked

BLACK PRI.

- Solder the long black lead to terminal 18 of S-2.
- Solder the green leads into the holes marked G.
- Solder the red leads into the holes marked R.

- () Slide the bare ends of the line cord under the cable clamp. Tie a knot in the cord 5" from the bare ends. Split the cord back to the knot. Solder one wire in the hole marked LINE on the board. Cut $2\frac{1}{2}$ " of the other wire. Solder it to terminal 17 of S-2.

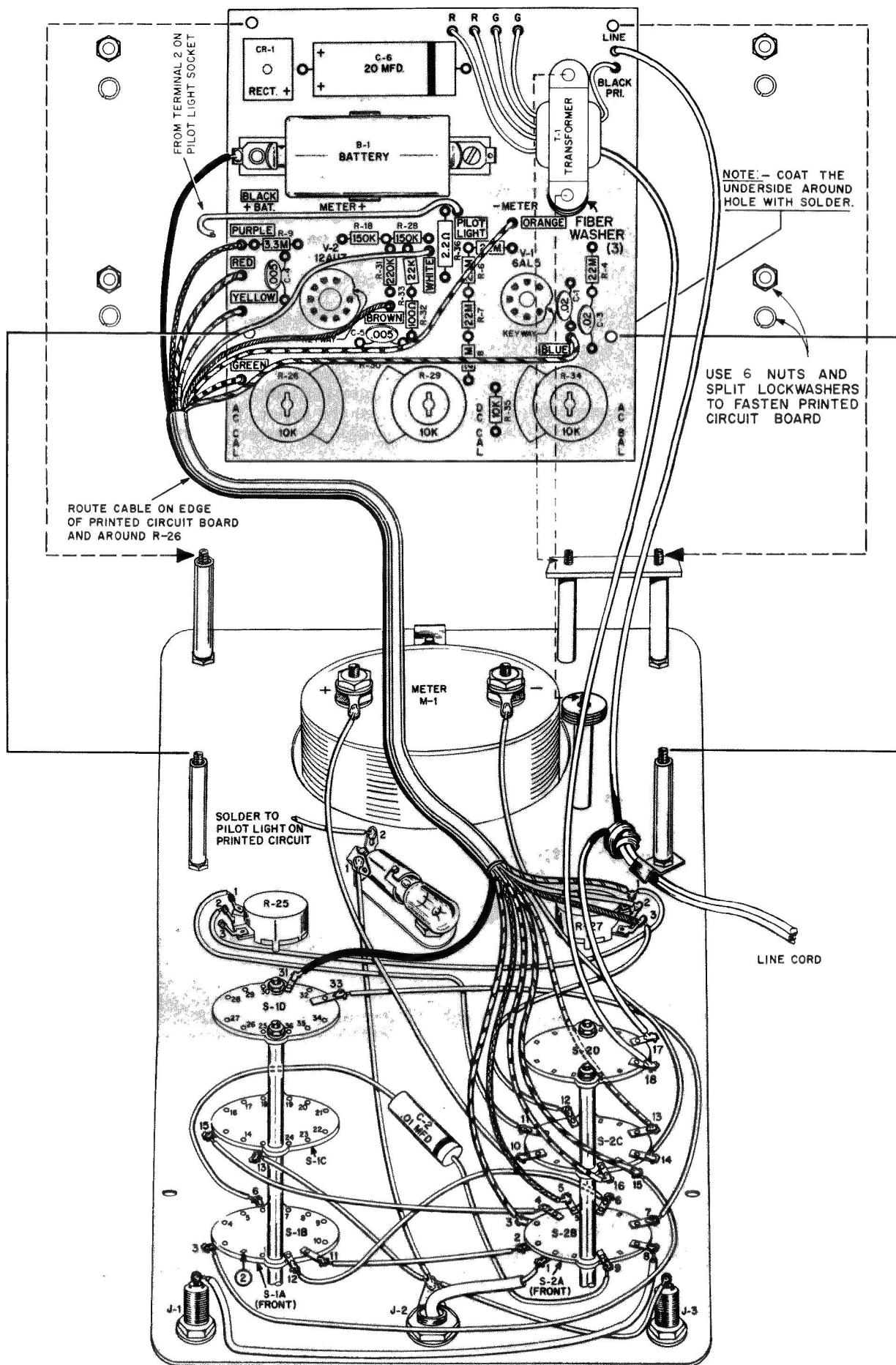

FIGURE 14. HOW TO MOUNT THE PRINTED CIRCUIT BOARD

PRELIMINARY ADJUSTMENTS

CAUTION: NEVER TOUCH ANY PART OF THE WIRING WHILE THIS INSTRUMENT IS PLUGGED INTO A POWER OUTLET. NEVER USE OR TEST THE VTVM ON OR NEAR A GROUNDED METAL BENCH, RADIATOR, SINK, OR OTHER GROUNDED METAL OBJECT.

- () Again check to see that the white line on the knob of S-1 lines up with the scale on the front panel. If not, loosen the nut and move S-1 so that it does. Retighten the nut.
- () Also check S-2.
- () Rotate the shafts of the OHMS ADJUST control, R-25, and the ZERO ADJUST control, R-27, fully counterclockwise. Place a small knob on each shaft so that the white line points to the lower left. Tighten each set screw.
- () Insert the 6AL5 tube in the 7-pin socket, V-1. Insert the 12AU7 tube (may be marked 12AU7A) in the 9-pin socket, V-2.
- () Plug the line cord into a 117 volt, 60 cycle, AC outlet. NEVER connect the VTVM to direct current or you will damage the instrument. If you are not certain as to the power available, check with your local power company.
- () Turn the VTVM on. Set the FUNCTION switch to either + DC or -DC volts. Set the RANGE switch to 1.5 volts. The pilot lamp and tubes should light. Turn the knob of the ZERO ADJUST control. The meter needle will deflect over at least part of the scale.
- () Leave the VTVM on while you prepare the test leads. This will give the tubes ample time for warmup before calibration.

TEST LEAD ASSEMBLY

SEE FIGURE 15.

There are three test leads to be prepared for your VTVM.

- () Remove the small setscrew from the cable plug and remove the spring from the plug. Slide the spring (large hole first) over one end of the shielded cable. Remove $\frac{1}{2}$ inch of the outer insulation from one end of the cable. Unravel the braid and bend it back over the spring. Remove $\frac{1}{8}$ inch of the insulation from the inner conductor. Insert the cable and spring into the open end of the plug.

The inner conductor must fit into the small hole of the plug. The braid and spring should fit into the plug so that the setscrew will tighten on the spring. Tighten the setscrew. Solder the inner conductor to the eyelet.

- () Remove $\frac{1}{2}$ inch of the outer insulation from the other end of the shielded cable. Trim the braided shielding back even with the cut off insulation. Remove $\frac{1}{4}$ inch of the insulation from the inner conductor. Form a small hook in it.
- () Cut one lead of R-37, 1 megohm 5% resistor, to $\frac{1}{4}$ inch. Form a small hook in it. Hook R-37 to the inner conductor of the shielded cable. Crimp the two together. Solder the connection. Do not overheat or the insulation around the inner conductor may soften.
- () Trim the other lead of R-37 to $\frac{5}{8}$ inch from the body.

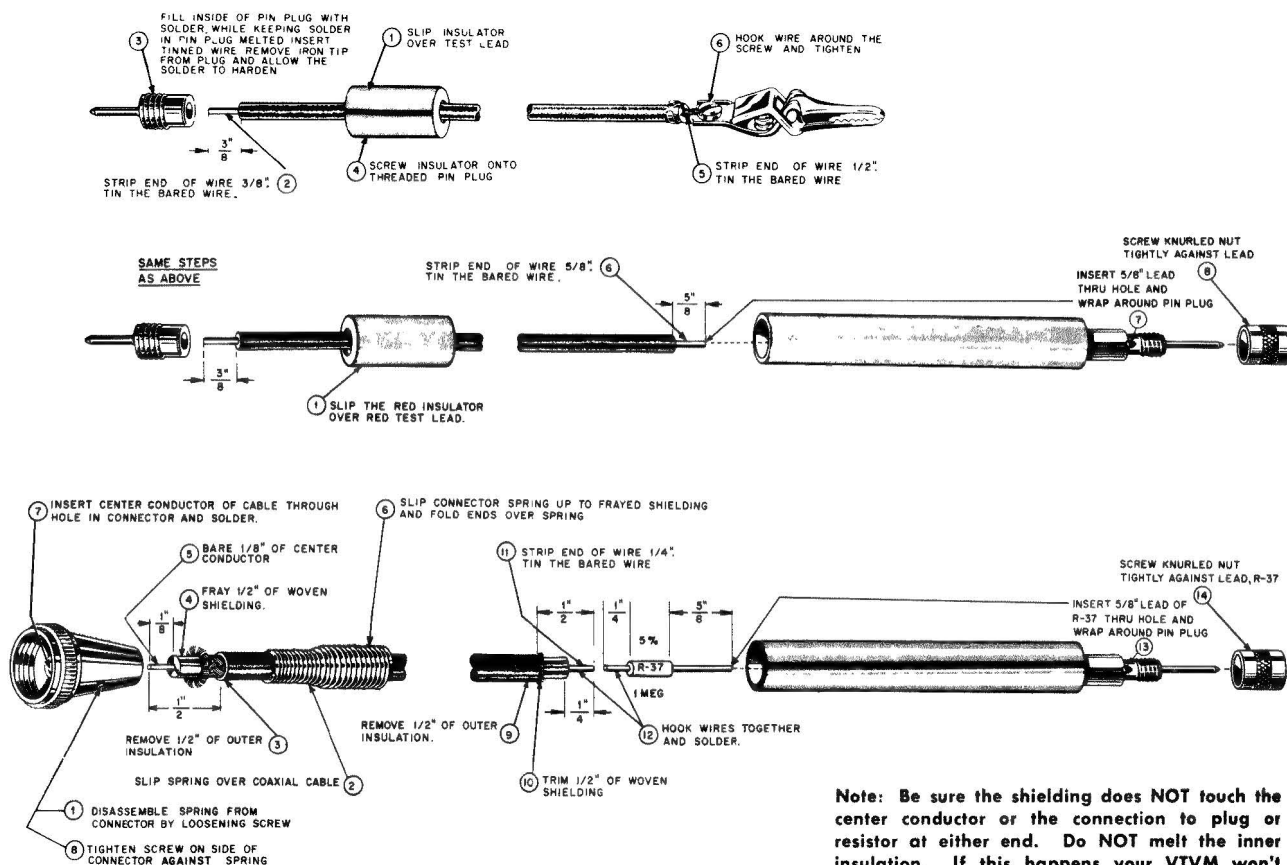

Note: Be sure the shielding does NOT touch the center conductor or the connection to plug or resistor at either end. Do NOT melt the inner insulation. If this happens your VTVM won't work on either + or -DC Volts.

FIGURE 15. HOW TO ASSEMBLE THE TEST LEADS

- () Insert the $\frac{5}{8}$ inch lead into the black prod handle and out the small hole near the threads on the prod tip. Pull R-37 through the prod handle and into the prod tip. Wrap the lead around the base of the prod tip. Screw the nut back onto the prod tip. Tighten it securely so that the lead of R-37 is held very firmly.
- () Remove $\frac{5}{8}$ " of the insulation from one end of the red test lead wire. Coat the fine wires with solder. Insert the end through the red prod handle and into the prod tip so the bared end comes through the small hole. Wrap it around the base of the prod tip. Screw the nut on very tightly.
- () Unscrew the short red insulator from the tip plug. Slide it over the other end of the red wire. Remove $\frac{3}{8}$ " of the insulation. Twist the wires and coat them with solder. Fill the tip plug with solder. Insert the bare end into the tip and let the solder cool.
- () Prepare one end of the black test lead in the same way.
- () Remove $\frac{1}{2}$ " of the insulation from the other end of the black test lead. Twist the wires and coat them with solder.
- () Loosen the screw at the back of the clip. Form a hook in the solder coated wires. Hook the wire around the screw in a clockwise direction. Tighten the screw. Now, bend the two small prongs at the back of the clip down around the insulation of the lead.

You have finished wiring your KNIGHT VTVM. Check all of your work very carefully. A few extra minutes spent checking your instrument may save hours of trouble-shooting. Be especially sure all the printed circuit connections are shiny.

MOUNTING THE HANDLE

- () Push the handle mounting studs through the hole in each end of the handle. Insert the stud through the hole in the meter case on one side. Use a large flat metal washer, a shakeproof washer and one of the larger hex nuts to fasten it.
- () Mount the other stud in the other side of the case.

USE OF THE CONTROLS

The FUNCTION SWITCH, S-2, serves two purposes. One, turns the power off when the switch is in the off position. Two, selects the operating function desired.

The RANGE SWITCH, S-1, provides wide choice of ranges for voltage and resistance measurements.

The ZERO ADJUST, R-27, controls meter needle position at the left zero position or sets the needle at the zero-center, "0", when the function switch is in VOLTS position.

The OHMS ADJUST potentiometer, R-25, positions the meter needle at the extreme right of the scale when the function switch is in the OHMS position.

The DC VOLTS chassis connector is used for all DC voltage measurements with the DC test prod. The black test lead must be plugged in the COMMON jack for all of these measurements.

The AC-OHMS jack is used for all AC voltage and resistance measurements. The red test lead must be plugged into this jack. The black test lead must also be plugged into the COMMON jack.

The COMMON jack is connected directly to the panel of the VTVM and is the return point for all measurements.

READING THE SCALES OF THE METER

Study the face of the meter on your VTVM. A reproduction of the meter scales is shown below. You will notice the scale for resistance is the top red scale. Read this scale from left to right. Each of the 7 positions of the RANGE switch is marked with a resistance multiplier. In the Rx1 position any value between 0 and 1000 ohms may be read directly. Ten is the multiplier for the next position, 100 for the next, 1000 the next, 10K (where K indicates 1000), 100K and 1 meg or 1,000,000. Therefore, the largest resistance which can be measured is 1000 megohms.

Knight

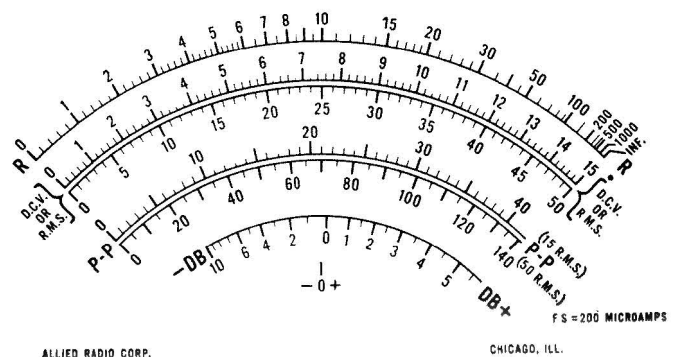

You will notice that the next two scales (black) are bracketed and marked D.C.V. or R.M.S. All DC and AC rms voltages are read on these two scales. The value of the voltage to be measured determines which scale to use. When making voltage measurements always start on a high range and work down. Make the final reading at mid-scale or higher for greater accuracy. You will also note that the RANGE switch is marked with numbers which are multipliers for all of the voltage scales.

The next two scales (red) are marked P-P, or peak-to-peak. The peak value of a sine wave is 1.414 times the rms value. Therefore, peak-to-peak values are 2.83 times rms. Peak-to-peak values are read directly on the two red scales. The first red scale, marked 0-40, corresponds to the first black scale. This is indicated on the meter face by 15 R.M.S. in parenthesis. The second red scale corresponds to the second black scale and is similarly marked 50 R.M.S. As an example, suppose the RANGE switch is set at 15V and an AC voltage of 10 volts rms is to be measured. The meter needle will stop at 10 on the rms scale. At the same

time you can read the peak-to-peak value of the sine wave on the corresponding P-P scale, or 28.3 volts. No calculations are necessary to convert rms to peak-to-peak or vice versa. Greater accuracy is assured as well as saving you time. Peak-to-peak voltages are used for waveform measurements such as are encountered in television service work.

The use of the decibel scale and zero center are explained in the section of this manual "USING YOUR VTVM".

CALIBRATION

Before you calibrate your VTVM, be sure the meter needle is at zero on the left side of the scale.

- () Turn the instrument off. If the needle is not at zero, adjust the screw above the pilot light. Turn the zero-adjustment screw either right or left as required to bring the meter needle to zero.

Turn the instrument on again.

Plug the line cord into an AC power outlet socket and leave the unit on for at least 8 hours (24 hours if possible) before proceeding. This allows the tubes to "age" and will permit the next step to be performed accurately. It will also result in more accurate DC CALIBRATION.

CAUTION: Do not touch any part of the wiring while the instrument is plugged in. Do not use the instrument on a grounded metal bench, radiator or other grounded object.

- () Set the FUNCTION switch, S-2, to the +DC position. Adjustment of the ZERO ADJUST control should move the needle approximately one-half scale. Reset the ZERO ADJUST control for zero. Set S-2 to the -DC position. If there is any change in the zero, re-adjust the ZERO ADJUST control. Repeat this procedure until there is no change in the zero when the FUNCTION switch is changed back and forth from +DC to -DC.

DC CALIBRATION

Insert the black pin jack into the common plug.

Attach the DC volts test cable to the connector on the front panel.

Set the FUNCTION switch to +DC.

Set the RANGE switch to 1.5 volts.

Use the battery which is included with your VTVM.

Attach the DC test prod to the positive end of the battery and the common test lead to the negative end of the battery.

Adjust R-29, the DC calibrate control on the printed circuit board, so that the needle of the meter rests exactly over the red dot at the extreme right edge of the scale.

Set the FUNCTION switch to -DC.

Connect the test leads to the battery in opposite polarity.

There should be no change in the position of the needle over the red dot. If there is, adjust the DC calibrate control until there is no change when switching back and forth from +DC to -DC.

AC CALIBRATION

Remove all test leads and recheck ZERO ADJUST setting.

Set FUNCTION switch to AC VOLTS and RANGE switch to 1.5V.

Adjust R-34, the AC Balance control on the printed circuit board, so that the needle reads exactly zero on the left side of the scale.

Set RANGE switch to 150V.

Disconnect the VTVM power cord from the AC outlet (do not turn the FUNCTION switch OFF). Attach the AC and common test leads to the instrument.

USE EXTREME CAUTION DURING THE NEXT STEPS

Connect the AC and common test leads across the line cord.

Connect the VTVM power cord to the AC power outlet. **Do not touch the case or the front panel of the VTVM as you make the following adjustment:** Adjust R-26, the AC Calibrate control on the printed circuit board, so that the meter reads 117 volts.

Disconnect the power cord from the AC outlet and disconnect the test leads from the line cord.

OHMS CALIBRATION

Turn off the VTVM.

Install the battery on the printed circuit board.

Turn the VTVM on.

Set the FUNCTION switch to ohms.

Adjust R-25 for full scale.

Touch the AC-OHMS and COMMON test leads together. The meter needle should indicate zero ohms.

FINAL ASSEMBLY

- () Turn the FUNCTION switch OFF and remove the line cord from the AC power outlet.
- () Install the meter in the case so that the clamp at the top of the panel hooks against the inside of the flange in the case.
- () Use the two self-tapping screws through the holes in the panel. Tighten them into the holes in the case.

For your convenience, three holes have been provided in the back of the meter case to "touch up" the calibration after the tubes have aged. The adjustments made accessible by these holes are (from left to right) AC CAL, DC CAL, and AC BAL.

HOW THE KNIGHT VTVM WORKS

SEE FIGURE 16.

The KNIGHT VTVM utilizes the basic principle of a vacuum tube which is: A tube can amplify without taking power from the voltage source applied to its grid. This instrument is extremely sensitive and stable because every measurement is made electronically.

A sensitive 200 microampere meter is the indicating component. The meter is in the cathode circuit of the 12AU7 twin triode tube, V-2. R-27, the zero adjust control, balances the two sections of the tube so that

there is no indication on the meter due to both sections of the control being equal when there is no applied voltage. When a voltage to be measured is fed into the grid of V-2, this balance is upset and the voltage can be read directly on the meter. The test voltage and the meter indicating current are directly proportional, so that the meter is calibrated directly. The meter is protected, because as stated before, the voltage to be measured is applied to the tube rather than the meter.

The test voltage applied to the tube is a maximum of 3 volts. Higher test voltages are reduced through the voltage divider with a total resistance of 10 megohms. The DC test prod includes a 1 megohm resistance in addition. The high input impedance of the VTVM enables you to make measurements in most circuits without disturbing the circuits.

When the instrument is used for making AC measurements, the 6AL5 tube, V-1, acts as a full wave rectifier. The output of this tube is directly proportional to the AC voltage to be measured. The DC output is fed through the voltage divider network the same as for DC measurements and is indicated in exactly the same way.

On the 500 and 1500 volt scales for AC measurements, the voltage to be measured is reduced through R-3 and R-2 before it is applied to V-1. This feature protects V-1 and all following circuitry since voltages greater than 150 volts are not applied to the tube.

The AC scales are calibrated in both RMS and peak-to-peak values.

The AC balance control provides proper meter indication for the applied AC voltage by cancelling out the contact potential between elements of V-1. The contact potential is cancelled out by the bucking voltage provided by the AC balance control. This control permits changing from AC to DC without re-adjusting the zero of the meter.

A 1.5 volt battery is connected through a series of multipliers and the unknown resistance to be measured creating a voltage divider across the battery. Part of the resulting battery voltage is applied to the 12AU7 causing a deflection in the meter. For these measurements the meter is calibrated in ohms.

There are two accessory probes which will make your KNIGHT VTVM an even more versatile instrument. One is the high-voltage probe which extends the range of the instrument to 50,000 volts, when on the 500 volt scale.

The other probe is the high-frequency probe. This probe further permits work in RF circuits up to 250 megacycles, yielding a direct reading in RMS volts.

The stock number of each probe is listed at the end of the Parts List.

USING YOUR VTVM

CAUTION: NEVER TOUCH ANY PART OF THE WIRING WHILE THE INSTRUMENT IS PLUGGED INTO AN AC OUTLET. Do not use the VTVM on a grounded metal bench, radiator, or other grounded object.

Remove the power from the equipment under test before you attach the test leads. If this cannot be done, use SPECIAL CARE not to touch grounded ob-

jects. Use only one hand at a time. Grasp the test prods on the handles, never on the metal tips. Stand on a well insulated floor.

It is a good policy to discharge filter capacitors before test leads are attached.

DC VOLTAGE MEASUREMENTS

Set the FUNCTION SWITCH to + or — DC volts as required.

Set the RANGE SWITCH to a range higher than the voltage to be measured.

Connect the common test lead.

Touch or connect the DC test prod to the high side of the voltage to be measured.

Reset the RANGE SWITCH to a scale where a reading will be obtained at almost full scale.

Read the DC voltage directly.

ZERO-CENTER INDICATION

This is a useful feature of the instrument since both the positive and negative DC voltages may be observed without changing the setting of the FUNCTION SWITCH.

Set the FUNCTION SWITCH to +DC or —DC volts, whichever gives zero centering of the meter needle. Either position may be used. The two sections of the 12AU7 may be slightly different so that zero center may not be obtained in both positions.

Rotate the ZERO ADJUST control so that the needle of the meter is at the center "0".

Set the RANGE SWITCH to a range at least twice that to be measured.

After the voltage has been tested, set the RANGE SWITCH to the lowest scale which allows the needle to stay on the scale.

When you have completed the measurement, reset the meter needle to the zero at the left of the scale.

AC VOLTAGE MEASUREMENT

Set the FUNCTION SWITCH to AC Volts.

Short the common test lead and the AC test lead together, and adjust the ZERO ADJUST control to position the meter needle at zero.

Set the RANGE SWITCH to a position higher than the voltage to be measured.

Connect the common lead to the ground side of the circuit.

Touch the AC-OHMS test lead to the hot side of the circuit.

Reset the RANGE SWITCH for a scale which will give an indication near full scale.

Since the human body picks up AC when near an AC circuit, the sensitivity of the KNIGHT VTVM causes the instrument to indicate this. Therefore, do not hold both test leads when making AC measurements.

RESISTANCE MEASUREMENTS

Set the FUNCTION SWITCH to ohms.

Set the RANGE SWITCH for the proper value.

Connect the common test lead to one side of the resistor to be measured.

Set the OHMS ADJUST Control so that the meter reads exactly full scale.

Touch the AC-OHMS test prod to the other side of the resistor.

Read the resistance on the ohms scale and multiply by the multiplier indicated by the setting of the RANGE SWITCH.

The instrument must be plugged into an AC power outlet when making resistance measurements as all indications are through the electronic meter circuit. Do not leave the FUNCTION SWITCH in the ohms position when you have completed the resistance measurements as this may greatly shorten the life of the battery.

DECIBEL MEASUREMENTS

A unit known as the "bel" was adopted as a unit of measurement for sound since the human ear does not respond to volume of sound in proportion to signal strength. The bel is more clearly equivalent to human ratios. The measurement is usually given in 1/10 of a bel which is known as a decibel. The KNIGHT VTVM db scale uses a standard of 1 milliwatt into a 600 ohm line as zero decibels. This corresponds to .774 volts AC on the 0-1.5 volt scale. Using this figure, the AC ranges may be converted to db by the following chart:

AC VOLTS SCALE	DECIBEL SCALE
0-1.5 volts	Read db directly
0-5 volts	Add 10 db to the reading
0-15 volts	Add 20 db to the reading
0-50 volts	Add 30 db to the reading
0-150 volts	Add 40 db to the reading
0-500 volts	Add 50 db to the reading
0-1500 volts	Add 60 db to the reading

For example, when measuring the gain of an amplifier, if the input reading is +4.5 db on the 1.5 volt range and the output reading is -5.5 db on the 500 volt range, the correct reading would be 50 plus 4.5 minus 5.5 or 49 db, which is the algebraic sum.

The decibel is a power or voltage ratio and may be used as such without specifying the reference level. Since this is true, a fidelity curve may be run by feeding in a signal of variable frequency but constant amplitude. At the reference frequency, adjust the input to give a convenient indication (zero db) on the VTVM connected to the output. The output variation may be read directly in db above and below the specified reference level as the input frequency is varied.

However, when measuring complex AC wave shapes, such as ripple, hum, distorted and square waves, the indication is 35% peak-to-peak.

SPECIAL APPLICATIONS

OSCILLATOR GRID-BIAS MEASUREMENTS. Set the FUNCTION SWITCH to DC. Select a suitable

range. Make comparative voltage readings on each band of a multi-band receiver and rotate the main tuning capacitor through each band while measuring the bias.

AVC-VOLTAGE MEASUREMENTS. Make this measurement at the diode-load resistor, along the AVC bus, or at the grids of the controlled tubes.

OUTPUT INDICATION. Set the FUNCTION SWITCH for DC. Make the measurement with the test prod connected to the load resistor of the second detector in AM and TV receivers while adjusting the components for optimum output. Connect the test prod to the limiter load resistor for an FM receiver.

BIAS-CELL VOLTAGE MEASUREMENTS. The low scales of 0-1.5 and 0-5 volts make small voltages easy and convenient to read when bias voltages are critical.

DETECTION OF GASSY TUBES. If a tube is gassy and does not show up on a tube tester, the bias voltage will have an abnormal value when checked in an RC-coupled circuit.

SERVICE HINTS

If you have followed all of the instructions and diagrams carefully, your KNIGHT VTVM should operate properly.

If it does not, recheck all of the wiring carefully. Most difficulties are the result of a wiring error. Often it is helpful to have someone else check the wiring, preferably someone with radio-TV or amateur experience.

Be sure that the shouldered fiber washer is on the inside of the panel on the AC-OHMS jack so that the jack is insulated from the panel. If this jack is not insulated from the panel, the house fuse will blow if you use your house line for calibrating on AC volts; and the needle will deflect fully to the right on OHMS indicating a short.

If a tube does not light, and you are absolutely certain the wiring on its socket is correct, its heater is open. Replace it with another of the same type.

If the tubes light and the instrument still does not operate properly, check each position of the FUNCTION switch and the RANGE switch. Determine if all functions are inoperative, or only one or two.

If your VTVM does not operate on DC volts, check your probe first. If the probe is open or shorted, there will be no reading on either + or - DC volts on any range.

If the instrument operates satisfactorily on DC volts and not on AC volts, the 6AL5 tube and its associated circuitry are at fault. If the meter will not zero on AC, check R-34.

If the instrument does not operate on the 500 and 1500 volt AC scales, check R-2 and R-3. If the instrument fails to operate on either AC or DC voltages, check the string of multipliers R-10, R-11, R-12, R-13, R-14, R-15, and R-16.

If the instrument fails to function properly on OHMS, first check the battery. If this is satisfactory, check the string of multipliers R-17, R-19, R-20, R-21, R-22, R-23, and R-24.

If the instrument is erratic in operation, that is varying deflection to the right on +DC volts, varying deflection to the left on -DC volts, and a "wavy"

deflection on AC, the bond between the board and the tube socket pins has probably been broken. Using more solder, again solder the connections.

Should there be no operation whatsoever, check the

VOLTAGE CHART

All measurements made with vacuum tube voltmeter from pin indicated to panel ground. FUNCTION SWITCH in AC Volts position. RANGE SWITCH in 1.5 volt position.

TUBE	PIN								
	1	2	3	4	5	6	7	8	9
6AL5	*	*	5.4AC	0	0	NC	-		
12AU7	77.0	0	3.5	0	0	77.0	0	3.5	5.4AC

* Non-significant voltages. NC - Not connected.

"D" wafer section of S-2. If this is OK, check the transformer. If the transformer is OK, check the rectifier. If all of the power supply components are satisfactory, the problem is in the 12AU7 or its associated circuitry.

RESISTANCE CHART

All measurements made with vacuum tube voltmeter from pin indicated to panel ground. FUNCTION SWITCH in off position.

TUBE	PIN								
	1	2	3	4	5	6	7	8	9
6AL5	*	*	1	0	0	NC	110M		
12AU7	20K	*	85K	0	0	20K	10M	85K	1

All values indicate ohms. *-Infinite. K equals 1000. M equals 1,000,000. NC - Not connected.

FIGURE 16. SCHEMATIC DIAGRAM, KNIGHT VTVM

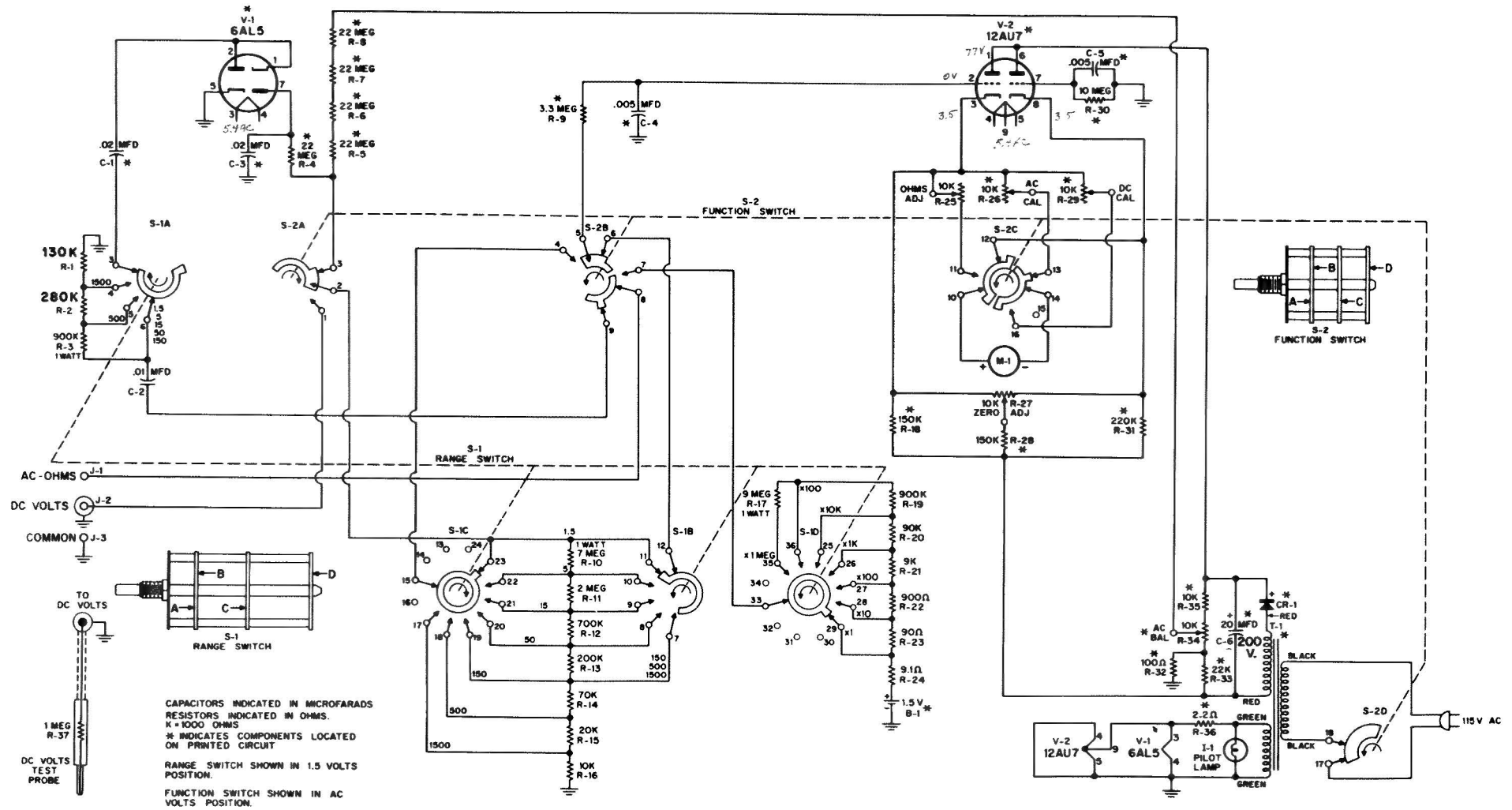

PARTS LIST

Symbol Number	Description	Allied Part No.	Description	Quantity	Allied Part No.
C-1	Capacitor, Disc, .02 MFD 600V.....	296009	Battery Clip Board	1	534001
C-2	Capacitor, Molded Tubular, .01 MFD 1600V.....	258015	Bracket, mounting	1	470371
C-3	Capacitor, Disc, .02 MFD 600V.....	296009	Cable, 9 Conductor	11"	803003
C-4	Capacitor, Disc, .005 MFD 600V.....	296000	Cable, Shielded	48"	803001
C-5	Capacitor, Disc, .005 MFD 600V.....	296000	Case	1	702086
C-6	Capacitor, Tubular Electrolytic, 20 MFD 200V.....	293007	Circuit Board, Printed Wiring	1	820007
Note: When ordering resistors, give complete description and part number.			Clamp, Cable	2	532001
R-1	Resistor, 130K - 1/2 W, ±1%	341303	Clip, Alligator	1	532005
R-2	Resistor, 280K - 1/2 W, ±1%	342803	Clip, Battery Retaining	1	534002
R-3	Resistor, 900K - 1W, ±1%	359003	Connector, Cable	1	502224
R-4	Resistor, 22 Megohm, 1/2 W, ±10%	301226	Control Nut, Hex, 3/8"	8	570840
R-5	Resistor, 22 Megohm, 1/2 W, ±10%	301226	Cord, Line	1	802001
R-6	Resistor, 22 Megohm, 1/2 W, ±10%	301226	Knob	4	761004
R-7	Resistor, 22 Megohm, 1/2 W, ±10%	301226	Handle, Black	1	870064
R-8	Resistor, 22 Megohm, 1/2 W, ±10%	301226	Nut, 4-40 Hex	2	570220
R-9	Resistor, 3.3 Megohm, 1/2 W, ±10%	301335	Nut, 6-32 Hex	3	570340
R-10	Resistor, 7 Megohm, 1W, ±1%	357004	Nut, 10-32 Hex	2	570540
R-11	Resistor, 2 Megohm, 1/2 W, ±1%	342004	Nut, 1/4-32	2	579751
R-12	Resistor, 700K - 1/2 W, ±1%	347003	Panel	1	463540
R-13	Resistor, 200K - 1/2 W, ±1%	342003	Pilot Light Assembly (with jewel, 641002 and 1/4" nut, 579401)	1	501721
R-14	Resistor, 70K - 1/2 W, ±1%	347002	Plug, Insulated Black Tip	1	502112
R-15	Resistor, 20K - 1/2 W, ±1%	342002	Plug, Insulated Red Tip	1	502111
R-16	Resistor, 10K - 1/2 W, ±1%	341002	Prod, Black Test	1	880002
R-17	Resistor, 9 Megohm, 1W, ±1%	359004	Prod, Red Test	1	880001
R-18	Resistor, 150K - 1/2 W, ±10%	301154	Screw, 4-40 x 3/8" B.H.	1	560224
R-19	Resistor, 900K - 1/2 W, ±1%	349003	Screw, 4-40 x 1/4" Flat Head	1	569773
R-20	Resistor, 90K - 1/2 W, ±1%	349002	Screw, 6-32 x 2" Flat Head	2	567348
R-21	Resistor, 9K - 1/2 W, ±1%	349001	Screw, 6-32 x 1/8"	1	560343
R-22	Resistor, 900 ohm, 1/2 W, ±1%	349000	Screw, #4 Pan Head, Self Tap	2	562292
R-23	Resistor, 90 ohm, 1/2 W, ±1%	340900	Sleeve, 1 3/8" Long Spacer	6	470007
R-24	Resistor, 9.1 ohm, 1/2 W, 5% Wirewound.....	312090	Socket, 7-pin Printed Circuit Miniature	1	501671
R-25	Potentiometer, 10K ohm, Carbon Pot, Linear Taper	390112	Socket, 9-pin Printed Circuit Miniature	1	501691
R-26	Potentiometer, 10K ohm, Carbon Pot, Linear Taper	390113	Solder, rosin core	48"	930001
R-27	Potentiometer, 10K ohm, Carbon Pot, Linear Taper	390112	Spaghetti, Small	7"	812001
R-28	Resistor, 150K - 1/2 W, ±10%	301154	Spaghetti, Large	7"	812003
R-29	Potentiometer, 10K ohm, Carbon Pot, Linear Taper	390113	Studs, Handle Mtg.	2	470025
R-30	Resistor, 10 Megohm, 1/2 W, ±10%	301106	Washer, Shoulder	2	591703
R-31	Resistor, 220K - 1/2 W, ±10%	301224	Washer, Split	2	581300
R-32	Resistor, 100 ohm, 1/2 W, 20% Carbon.....	300101	Washer, Fiber, Large	12	590301
R-33	Resistor, 22K - 1/2 W, ±10%	301223	Washer, Fiber, Small	1	590300
R-34	Potentiometer, 10K ohm, Carbon Pot, Linear Taper	390113	Washer, #6 Flat Steel	1	580200
R-35	Resistor, 10K - 1/2 W, ±10%	301103	Washer, #10 Flat Steel	2	580501
R-36	Resistor, 2.2 ohm, 1/2 W, 5% Wirewound.....	312020	Washer, 3/8" Lock	2	582700
R-37	Resistor, 1 Megohm, 1/2 W, ±5%	302105	Washer, External Tooth #6 Lock	1	583300
S-1	Switch, Range, 3 Section, 7 Position.....	432301	Washer, Internal Tooth #6 Lock	2	582300
S-2	Switch, Function, 3 Section, 5 Position.....	432300	Washer, Internal Tooth #10 Lock	2	582500
T-1	Transformer, Power	101301	Wire, Red Hookup, 2"	5	801002
V-1	Tube, 6AL5	611005	Wire, Orange Hookup, 3"	2	801003
V-2	Tube, 12AU7	611001	Wire, Yellow Hookup, 4"	2	801004
I-1	Pilot Bulb, #47.....	640002	Wire, Green Hookup, 5"	5	801005
J-1	Jack insulated red tip	509053	Wire, Blue Hookup, 6"	2	801006
J-2	Cable Connector, Chassis Mtg.	502122	Wire, Violet Hookup, 7"	2	801007
	consists of:		Wire, #20 Bare Hookup	13"	806013
	1 Washer, flat fiber	590701	Wire, Rubber Covered Black Test Lead	48"	804019
	1 Solder lug	553003	Wire, Rubber Covered Red Test Lead	48"	804020
	1 Washer, flat metal	580702			
	1 Nut	570850			
J-3	Jack, Insulated Black Tip	509054			
M-1	Meter, 200 μAmp.	654208			
CR-1	Rectifier, Selenium, 50 MA.	620004			
B-1	Battery, Type 1 Size "C"	450011			

ACCESSORIES YOU MAY WANT

Allied Stock No.	Description
83Y126	High-Voltage Probe
83Y127	RF Probe

KNIGHT-KIT SERVICE FACILITIES

TECHNICAL CONSULTING SERVICE

If, after following the instructions and suggestions given in this manual you are still unable to obtain proper performance from your kit, we invite you to contact our Technical Consulting Service for further assistance. Please be as accurate and thorough as possible because the effectiveness of our advice depends entirely on the information you supply.

Use the following as a guide for your correspondence:

1. Have you checked all the suggestions under Service Hints? Careful consideration of these points may solve your problem without writing.
2. Be sure to give the kit model number, the date of purchase and the serial numbers on the label pasted on the chassis and the back cover of the manual.
3. Have you made a thorough check of all wiring and soldering? Each solder connection should have a shiny metallic finish. Reheat any connection that appears doubtful and add a little solder if needed. Be sure there are no parts accidentally touching each other, the chassis or nearby terminals.
4. If the kit is of the type that requires calibration or alignment, double check these procedures. Be as specific as possible in your report. Outline adjustments made and the alignment procedure employed.
5. When you write be sure to describe all associated equipment. Specifically note the switch positions. Define as clearly as possible the symptoms as noted and mention any particular circumstance under which the problem occurs (after unit has been on for some time, only when jarred or moved, only when used for a particular purpose, etc.).
6. If you have completed the recommended service hints, be sure to outline the results and note any measurements taken which are out of tolerance.

INSPECTION SERVICE

You may return your completed Knight-Kit for inspection and repair within **one year from purchase** for a service charge of \$5.00 for this particular kit. An additional charge will be made for parts damaged in construction. If the meter movement must be replaced because of burnout or other abuse, another \$10.25 will be charged.

Kits not completely wired or which require extensive re-work will incur an additional labor charge. You will be notified of these charges prior to our repairing your kit.

No service charge will be made for a **period of 90 days from date of purchase**, if malfunctioning of the completed kit is due to a defective part. Service charges for kits returned **after the one year period** will be on a time and materials basis.

PACKING INSTRUCTIONS

Should you find it necessary to return your Knight-Kit, be sure to pack it carefully. The original carton should be used, if available. If not, a sound carton of similar size may be used. **TO PREVENT COSTLY DAMAGE IN TRANSIT**, cushion your Knight-Kit tightly using plenty of packing material. Mark: **FRAGILE-DELICATE ELECTRONIC EQUIPMENT**.

SHIPPING INSTRUCTIONS

Ship your unit by Parcel Post **Insured**. Please include remittance to cover repair costs plus return postage and insurance. Postage and insurance may be estimated by referring to the "how to order page" in our catalog. This will save you costly COD fees; any excess remittance will be refunded.

When you return a kit please enclose your order papers and a letter explaining why you are returning the unit. On the front of the package print "**FIRST CLASS LETTER ENCLOSED**" and apply postage on the package for the enclosed letter.

ADDRESS CORRESPONDENCE AND RETURN KITS TO:

KNIGHT ELECTRONICS CORP. • Knight-Kit Service Department
2100 Maywood Drive • Maywood, Illinois

KNIGHT-KIT PARTS WARRANTY

Knight Electronics guarantees that only premium-quality parts are selected for use in Knight-Kits. Every Knight-Kit part is fully warranted for a period of one year from date of purchase against defects in material and workmanship. Prompt No-Charge replacements of defective parts will be made.

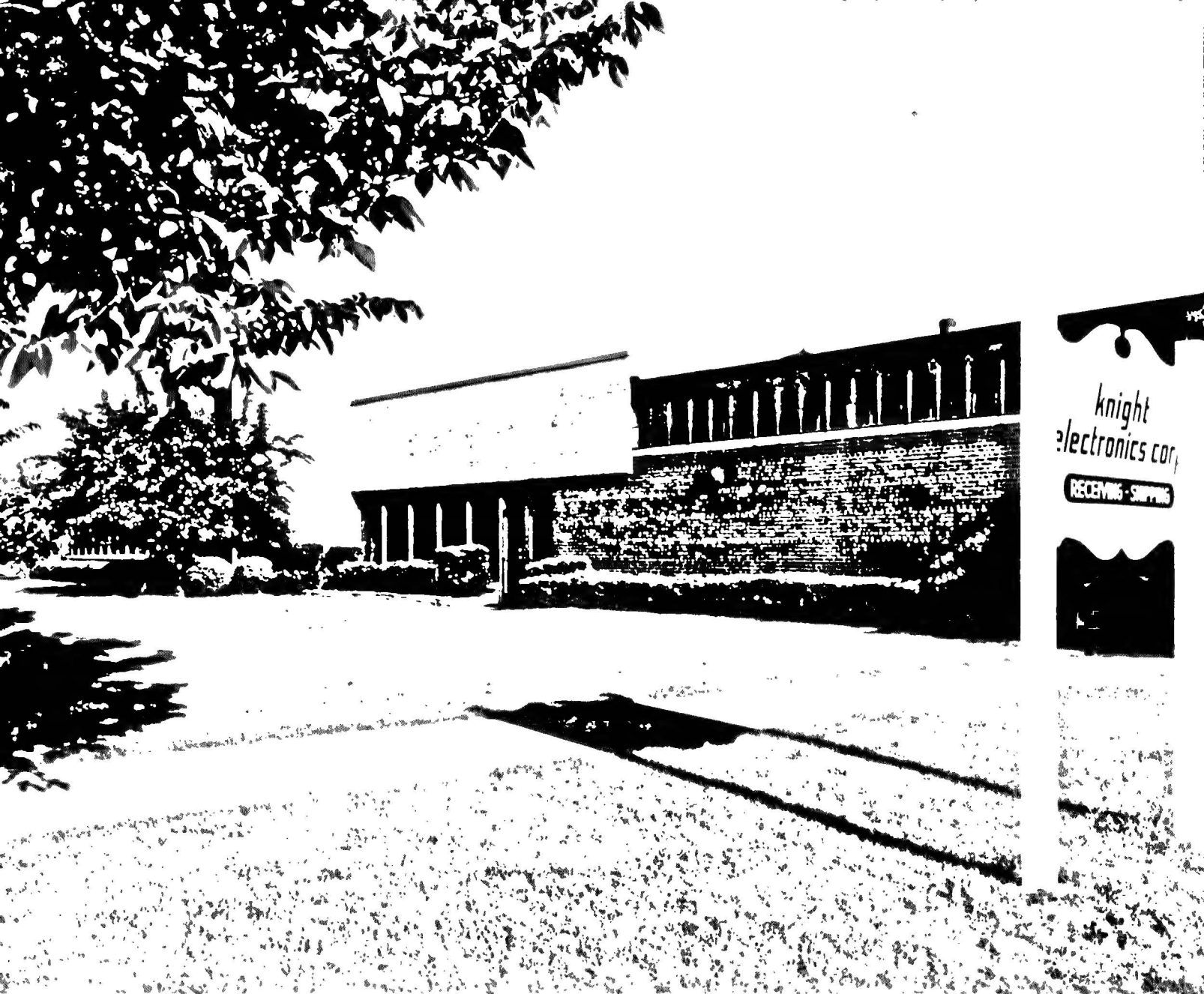

This is the new Knight Electronics Corporation Plant in Maywood, Illinois - A facility completely devoted to research, engineering, and manufacturing of electronic equipment in kit form. Here Knight pioneers in better electronic units at lower cost for electronic hobbyists, experimenters, laboratories, schools, and for industry.

knight electronics corporation - A DIVISION OF ALLIED RADIO



KNIGHT-KITS ARE YOUR BEST BUY. THEY REPRESENT THE FINEST ELECTRONIC EQUIPMENT IN KIT FORM. TRULY CREATIVE ENGINEERING AND THE USE OF PREMIUM QUALITY PARTS ASSURE SUPERIOR PERFORMANCE.

KNIGHT-KITS ARE "CONVENIENCE ENGINEERED". EVERY DETAIL IS PLANNED FOR EASY CONSTRUCTION. RESISTORS ARE CARD-MOUNTED AND IDENTIFIED; WIRE IS PRECUT; SMALL PARTS ARE PACKAGED IN TRANSPARENT PLASTIC BAGS. SUPERB STEP-BY-STEP "SHOW HOW" MANUALS MAKE KNIGHT-KITS EASIEST TO BUILD.

KNIGHT-KITS ARE THE FIRST CHOICE OF EXACTING BUILDERS OF ELECTRONIC EQUIPMENT . . . THIS HAS BEEN TRUE SINCE THE EARLY 20'S. THERE IS AN OUTSTANDING KNIGHT-KIT FOR EVERY REQUIREMENT. EACH IS A REWARDING EXPERIENCE IN KIT CONSTRUCTION. YOU WILL BE PROUD TO BUILD AND OWN A KNIGHT-KIT.

*your **knight-kit**[®] guarantee*

ALLIED *fully protects your Knight-Kit purchase with this exclusive*

Your Knight-Kit must meet with your complete satisfaction or your purchase price is refunded