

W 860329

INSTRUCTION MANUAL

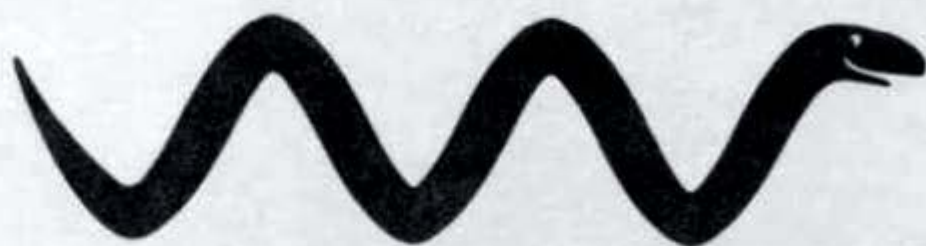

sinadder™ Linear 5

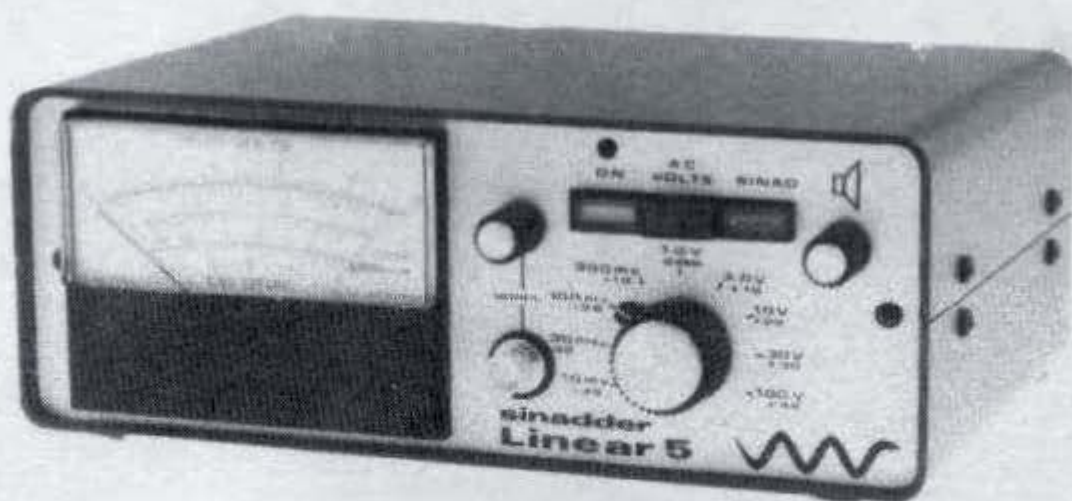

HELPER INSTRUMENTS COMPANY

131 Tomahawk Drive
Indian Harbour Beach, FL 32937

CML-1 ADDENDUM

The CML-1 is identical to the SINADDER LINEAR 5 as described in the accompanying manual except for the following:

A C-message weighting noise filter switch on the front panel permits insertion of a C-message noise filter in the input of the instrument.

This filter is accurate to within 1 dB.

This filter is in compliance with AMPS specifications as required for cellular radio.

When using voltmeter with C-message filter, input voltage should not exceed 20 dB above the full scale value of range in use. Higher inputs will saturate voltmeter input stage.

Helper Instruments Company

HELPER INSTRUMENTS COMPANY

631-Tenthawk Drive

Sanford, Florida 32087 U.S.A.

HELPER INSTRUMENTS COMPANY

SINADDER LINEAR 5, MODEL SL 105

Specifications:

Panel Controls: Power/AC VOLTS/SINAD Switch; RMS VOLTS Range Switch; 1 KHz tone output level control; internal speaker level control.

Input: Permanently affixed shielded test cable w/ miniclips.

SINAD Input Level: 20 mv. to 10 VRMS.

SINAD Input Impedance: 100K ohm

Notch: Audio frequency band rejection filter Per RS 204C, Paragraph 6.1.1 (a) (b) (c).

SINAD Accuracy: ± 1 dB

SINAD Scale Range: LINEAR 0 to 24 dB, RMS, 12 dB Center Scale.

AC RMS Voltmeter Ranges: Nine RMS Ranges: 10 mv, 30 mv, 100 mv, 300 mv, 1 V, 3 V, 10 V, 30 V, 100 V full scale.

AC Voltmeter Input Impedance: 1 Megohm

AC Voltmeter Accuracy: $\pm 3\%$ of full scale ± 0.25 dB, 100 Hz to 20 KHz.

Audio Amplifier: In SINAD mode, AGC controlled constant level with volume control.
In VOLTMETER mode, range switch and front panel volume control.

Internal Tone: 0 - 1.5 V, 1 KHz ± 1 Hz, lo impedance transformer isolated.

Power: 115/230 VAC $\pm 15\%$ Strap selectable, 50/60 CPS
13.5 VDC $\pm 15\%$.

Size: 8.75" W x 3.25" H x 7" D

SINADDER LINEAR 5, Model SL 105



GENERAL DESCRIPTIONS

The SINADDER LINEAR 5 contains the following instrument functions:

1. An RMS MEASURING LINEAR SINAD DISTORTION METER for making SINAD measurements. The unique circuit design speeds and simplifies SINAD measurements by eliminating distortion meter adjustments. The null circuits of the LINEAR 5 are internally set to the 1,000 Hz tone used for SINAD measurements. An automatic gain control circuit eliminates the need for setting input gain and permits the LINEAR 5 to be used as an alignment aid, providing rapid alignment of receivers for optimum performance.
2. A HIGH IMPEDANCE AUDIO FREQUENCY RMS VOLTMETER with nine ranges, from 10 millivolts to 100 volts full scale. Input impedance is one megohm, and a D.C. blocking condenser is provided.
3. An AUDIO AMPLIFIER and SPEAKER with gain control for audio monitoring of signals connected to the voltmeter, and of receiver audio when using the LINEAR SINAD function.
4. A LOW DISTORTION 1,000 Hz OSCILLATOR. This oscillator may be used as the signal modulation source for SINAD measurements, a transmitter modulation test source, or a tone source for signaling and other uses. Oscillator output voltage is front panel controlled. Output is transformer isolated.

OPERATING INSTUCTIONS

Refer to Figure 1, "Operating Controls".

SINAD MEASUREMENT. If you are not familiar with SINAD measurements, be sure to read the section, "A FEW WORDS ABOUT SINAD MEASUREMENTS", beginning on Page 5.

SINADDER 5 CONTROLS & FUNCTIONS

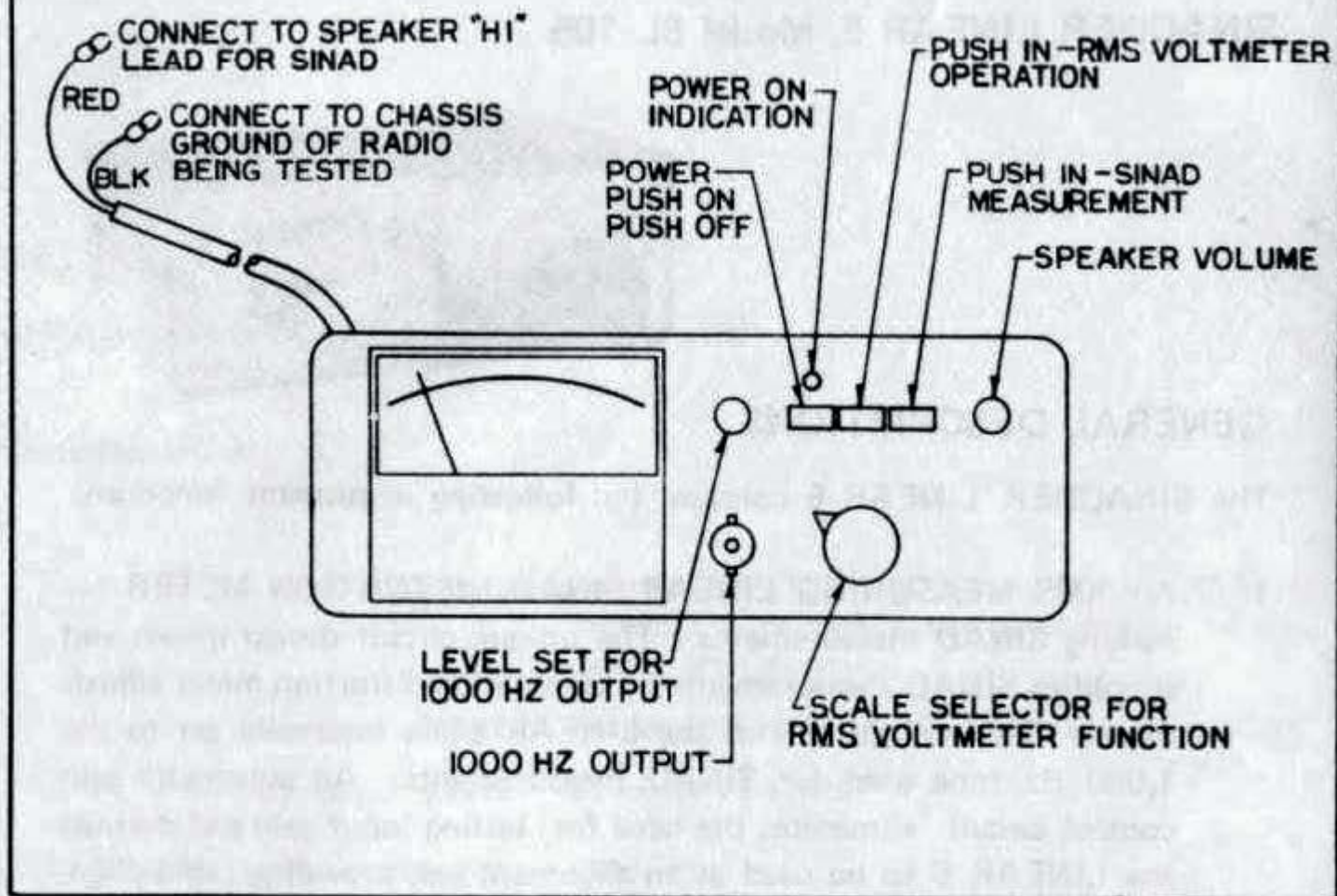

Figure 1

Before using the LINEAR 5 with a specified signal generator, check the 1,000 Hz modulating tone of the generator to be certain it is accurate enough to fall in the center of the LINEAR 5's null circuit. To do this, simply connect the modulating signal directly to the LINEAR 5 test leads, switch to SINAD function and see if the LINEAR 5 meter needle goes off scale to the left at the 24 dB SINAD mark. If your generator's oscillator is not accurate enough, use the 1,000 Hz generator in the LINEAR 5 as a modulation source. Connect the transformer isolated 1,000 Hz output directly to the signal generator modulation input. 1,000 Hz output level can be adjusted by the "1000 Hz" control on the LINEAR 5 front panel.

Now, for the SINAD measurement: Connect the leads from the LINEAR 5 to the loudspeaker output of the receiver under test, with the black lead going to the speaker ground terminal. Connect the signal generator to the receiver. Set the signal generator on frequency with 1 KHz tone modulation ± 3 KHz deviation using either the internal tone source or the 1 KHz output of the LINEAR 5. Adjust the signal generator RF output level until you are reading 12 dB SINAD on the LINEAR 5. Read the microvolts output of the signal generator. This is the 12 dB SINAD sensitivity of the receiver under test.

Refer to Figure 2.

Now that you have measured the receiver's sensitivity with the LINEAR 5, don't stop there! Odds are you can improve the sensitivity by a few dB by touching up the front end alignment adjustments, using the LINEAR 5 as an indicator of optimum performance.

Set the signal generator level so the LINEAR 5 reads about 12 dB. Tweak the various front end adjustments to make the meter swing as far to the left as you can. If you get below 18 to 20 dB, reduce the signal generator output to bring the meter reading back to about 12 dB. Even a receiver that has been accurately aligned by other methods will generally show an improvement in sensitivity when aligned by SINAD.

Ever have a receiver in the shop that seemed to need realignment, but you were afraid to try it without an instruction manual? You can do the realignment with the LINEAR 5. Just set the signal generator to about the 12 dB SINAD reading, and tweak away at the alignment screws. If you don't move any adjustment very far from its original setting, you won't go wrong. But watch out for sets with AFC circuits. If your realignment doesn't leave the AFC voltage properly centered, the receiver may "rest" off to one side of the channel.

Try using the LINEAR 5 for alignment of a few receivers. Once you have gained confidence in it, you will find it is a great timesaver. Receivers will leave your bench quicker, and working better.

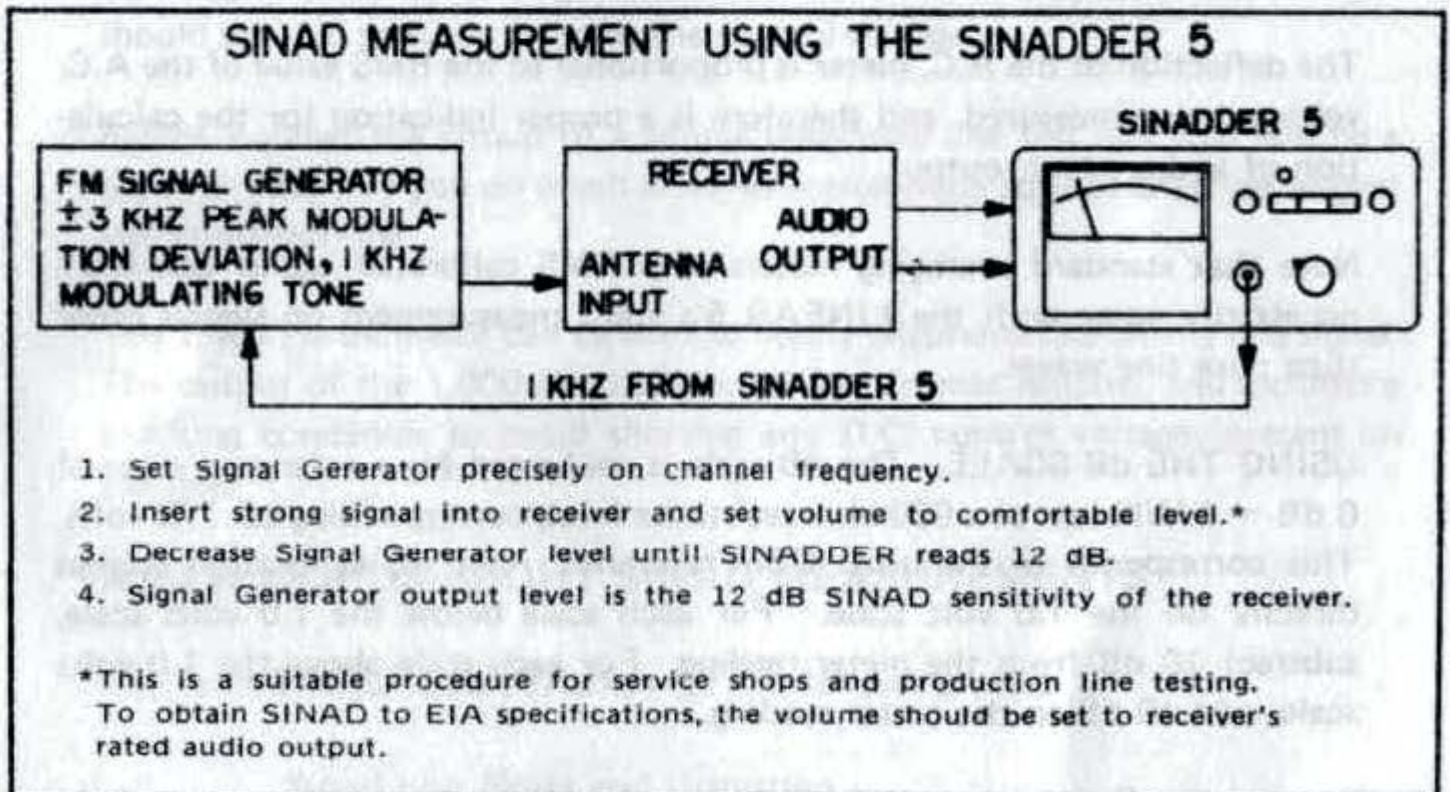

Figure 2

SINADDER 5 CONTROLS & FUNCTIONS

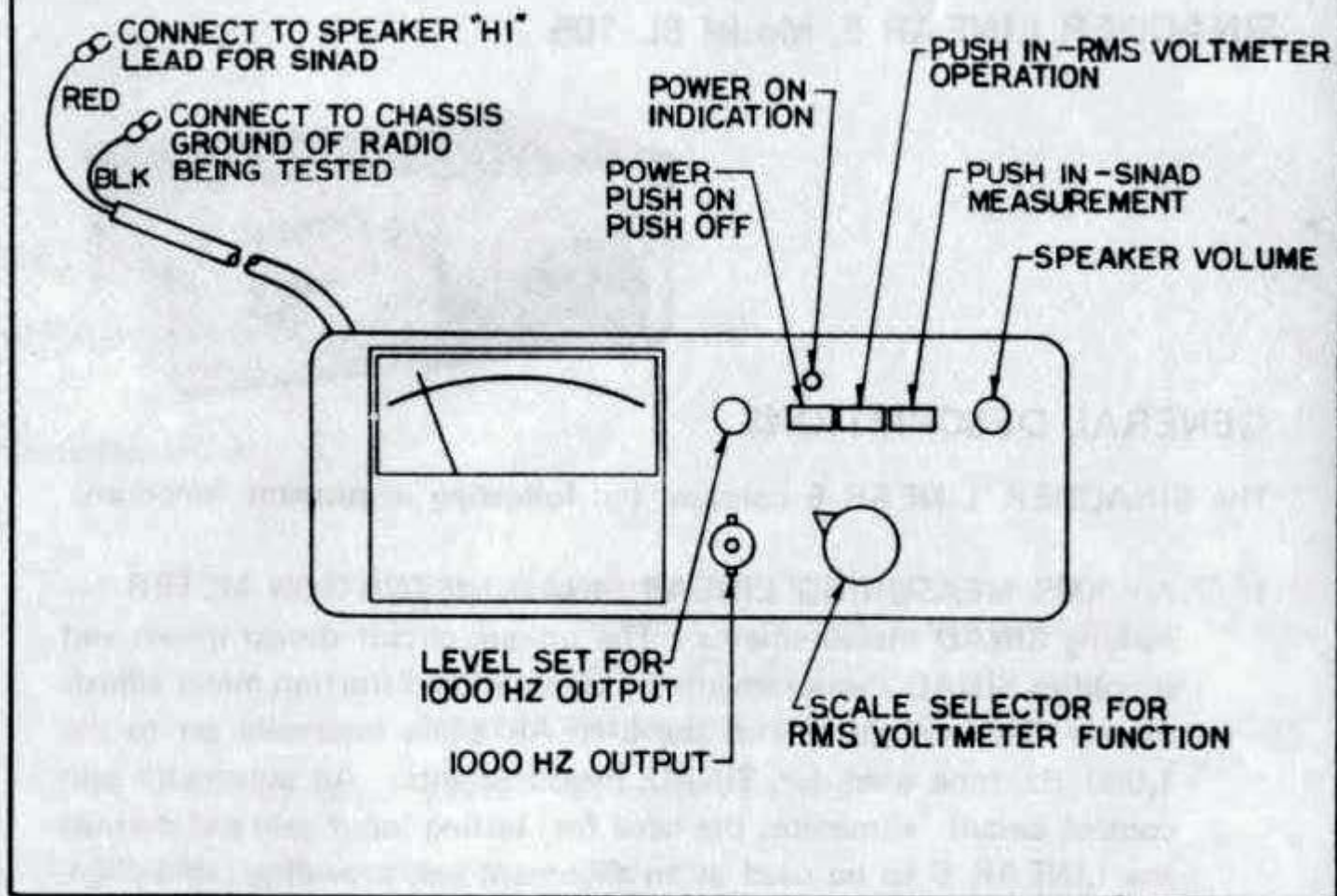

Figure 1

Before using the LINEAR 5 with a specified signal generator, check the 1,000 Hz modulating tone of the generator to be certain it is accurate enough to fall in the center of the LINEAR 5's null circuit. To do this, simply connect the modulating signal directly to the LINEAR 5 test leads, switch to SINAD function and see if the LINEAR 5 meter needle goes off scale to the left at the 24 dB SINAD mark. If your generator's oscillator is not accurate enough, use the 1,000 Hz generator in the LINEAR 5 as a modulation source. Connect the transformer isolated 1,000 Hz output directly to the signal generator modulation input. 1,000 Hz output level can be adjusted by the "1000 Hz" control on the LINEAR 5 front panel.

Now, for the SINAD measurement: Connect the leads from the LINEAR 5 to the loudspeaker output of the receiver under test, with the black lead going to the speaker ground terminal. Connect the signal generator to the receiver. Set the signal generator on frequency with 1 KHz tone modulation ± 3 KHz deviation using either the internal tone source or the 1 KHz output of the LINEAR 5. Adjust the signal generator RF output level until you are reading 12 dB SINAD on the LINEAR 5. Read the microvolts output of the signal generator. This is the 12 dB SINAD sensitivity of the receiver under test.

Refer to Figure 2.

Now that you have measured the receiver's sensitivity with the LINEAR 5, don't stop there! Odds are you can improve the sensitivity by a few dB by touching up the front end alignment adjustments, using the LINEAR 5 as an indicator of optimum performance.

Set the signal generator level so the LINEAR 5 reads about 12 dB. Tweak the various front end adjustments to make the meter swing as far to the left as you can. If you get below 18 to 20 dB, reduce the signal generator output to bring the meter reading back to about 12 dB. Even a receiver that has been accurately aligned by other methods will generally show an improvement in sensitivity when aligned by SINAD.

Ever have a receiver in the shop that seemed to need realignment, but you were afraid to try it without an instruction manual? You can do the realignment with the LINEAR 5. Just set the signal generator to about the 12 dB SINAD reading, and tweak away at the alignment screws. If you don't move any adjustment very far from its original setting, you won't go wrong. But watch out for sets with AFC circuits. If your realignment doesn't leave the AFC voltage properly centered, the receiver may "rest" off to one side of the channel.

Try using the LINEAR 5 for alignment of a few receivers. Once you have gained confidence in it, you will find it is a great timesaver. Receivers will leave your bench quicker, and working better.

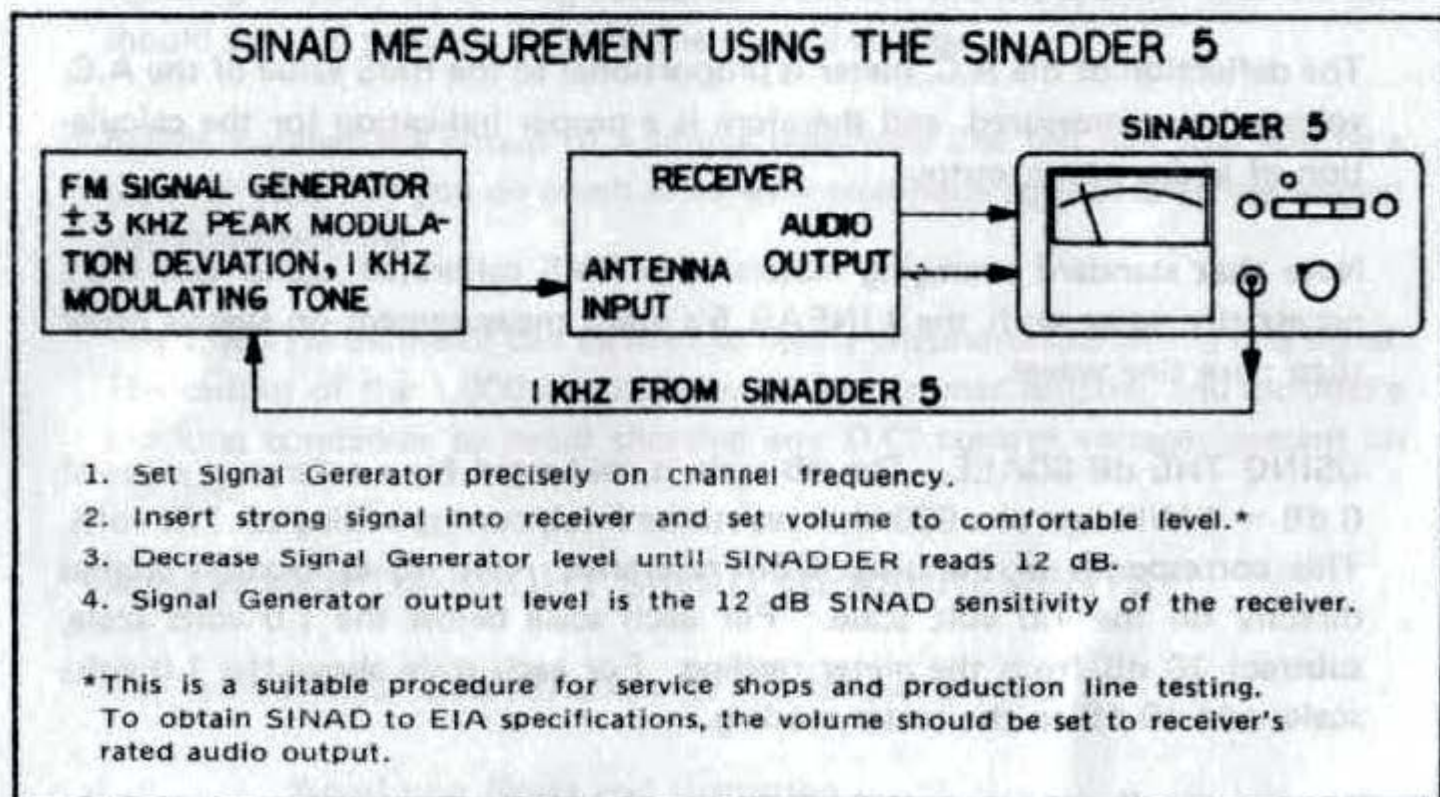

Figure 2

If you are working with a receiver that is not equipped with a loudspeaker, you can audibly monitor the receiver output with the LINEAR 5 loudspeaker. Turn the front panel loudspeaker control to obtain the desired volume. Since the monitor amplifier in the LINEAR 5 is fed from an AGC amplifier, you will not hear variations in volume even though the receiver output level may change radically.

AC VOLTMETER OPERATION

WARNING: VOLTAGES WITHIN THE MEASUREMENT CAPABILITY OF THIS INSTRUMENT ARE DANGEROUS AND CAN BE FATAL. USE PROPER SAFETY PROCEDURES AT ALL TIMES. THE COMMON (BLACK) TEST LEAD IS CONNECTED TO THE CASE OF THE INSTRUMENT. THE COMMON (BLACK) TEST LEAD, AND THE INSTRUMENT CASE ARE CONNECTED TO THE POWER LINE GROUND SYSTEM THROUGH THE GROUNDING CONNECTOR OF THE THREE WIRE LINE CORD.

To use the LINEAR 5 as an RMS A.C. Voltmeter, push the AC Volts switch and set the range switch to a range approximating the voltage to be measured. The black test lead is normally connected to the chassis (ground) of the equipment being tested. The red test lead is then connected to the points where voltage measurements are wanted.

An internal blocking condenser permits the meter to be used for measuring the A.C. component only, of voltages which combine both A.C. and D.C. Do not exceed 200 VDC.

The deflection of the A.C. meter is proportional to the RMS value of the A.C. voltage being measured, and therefore is a proper indication for the calculation of audio power output.

Note that standard averaging meters with RMS calibrated scales will NOT necessarily agree with the LINEAR 5's RMS measurement on signals other than pure sine waves.

USING THE dB SCALE. The dB scale is calibrated for a reference value of 0 dB = 1 Milliwatt at a 600 ohm resistance level, corresponding to .775 volts. This corresponds to the usual DBM reference. The dB calibration applies directly on the 1.0 volt scale. For each scale below the 1.0 volts scale, subtract 10 dB from the meter reading. For each scale above the 1.0 volts scale, add 10 dB to the meter reading.

When you are using the LINEAR 5 as an Audio voltmeter, you can audibly monitor the signals you are measuring with the built-in loudspeaker. The volume adjustment is to the right of the push switches. The voltage range

switch inserts a proper amount of attenuation into the input of the loud-speaker amplifier -- thus the amplifier always receives the proper input voltages whether you are observing signals of 10 millivolt or 100 volt magnitudes.

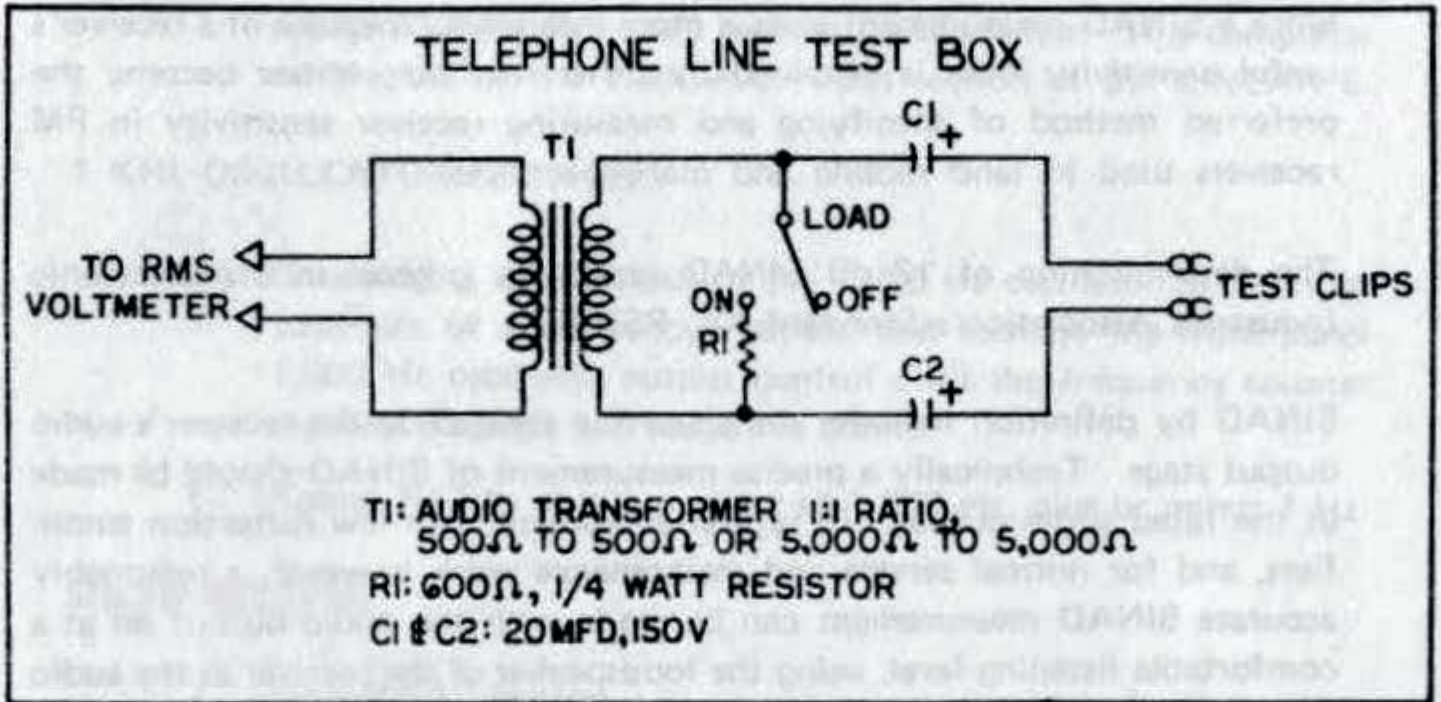

Figure 3

MEASURING AND MONITORING TELEPHONE CONTROL LINES. The LINEAR 5 is a very handy instrument for checking telephone control lines.

Proper measurement of a telephone line requires a transformer, which prevents inserting any unbalanced ground currents into the telephone line. If the telephone line being measured is not terminated into the equipment, a 600 ohm termination resistance should be connected across the line. When D.C. signaling is used, a blocking condenser between the transformer and the line should be used to avoid shorting the control voltage.

Figure 3 shows the circuit of a simple telephone line test box that will be a big time saver. If you do much work with telephone control lines, we suggest you construct one.

The 1,000 Hz oscillator can be used to feed a telephone line with a test signal. The output of the 1,000 Hz oscillator is transformer isolated, and includes a blocking condenser to avoid shorting any D.C. control voltages present on the line.

A FEW WORDS ABOUT SINAD MEASUREMENTS

The term SINAD is abbreviation for the following ratio:

$$\frac{\text{Signal plus Noise and Distortion}}{\text{Noise plus Distortion}}, \text{ expressed in Decibels}$$

The signal level at which a receiver produces a 12 dB SINAD ratio is referred to as the 12 dB SINAD sensitivity of receiver. In practice, a 12 dB SINAD signal is a reasonably intelligible and useful signal for speech transmission.

Since a SINAD measurement gives a more meaningful measure of a receiver's useful sensitivity than is obtained by other methods, it has become the preferred method of specifying and measuring receiver sensitivity in FM receivers used in land mobile and marine services.

The determination of 12 dB SINAD sensitivity is given in the Electronic Industries Association's Standard No. RS204C.

SINAD by definition includes the distortion created by the receiver's audio output stage. Technically a precise measurement of SINAD should be made at the rated audio output. In typical equipment with low distortion amplifiers, and for normal service and maintenance work however, a reasonably accurate SINAD measurement can be made with the audio output set at a comfortable listening level, using the loudspeaker of the receiver as the audio load.

ABOUT ACCURACY.

For precise determination of the ratio implied by the SINAD definition, the measurement circuits of the SINAD meter must measure RMS values of the composite signal, noise, and distortion waves. RS204C, revised January, 1982, specifies the 1,000 KHz notch filter requirements. The LINEAR 5 uses both RMS metering and the appropriate 1,000 Hz notch circuit for full compliance with the RS204C, January, 1982 specification.

ABOUT THAT METER FLICKER.

The flickering of the meter pointer is caused by the statistical nature of the noise in the receiver output. Since this flickering is a basic fact of nature, the only way to reduce it (and still make a true SINAD measurement) would be to slow down the meter response time. This response is, in fact, slowed down by the meter circuit, but further slowing should result in an annoying lag between an adjustment on the radio and the resulting meter indication.

CALIBRATION INSTRUCTIONS:

RMS A.C. VOLTS SECTION.

1. With power off, set the mechanical zero on the meter so the meter pointer is exactly at the 0 voltage line.

2. Turn on the instrument power. Push A.C. VOLTS button. Set range switch to the 1.0 volts range.
3. Short input leads, and adjust R27 for zero meter deflection.
4. Connect the input leads to a 1 KHz, 1 Volt RMS source, and adjust R44 for full scale reading on the meter. This completes calibration of the RMS A.C. Volts section of the LINEAR 5.

1 KHz OSCILLATOR SECTION:

5. Connect the BNC output of the 1,000 Hz oscillator to the input terminals of a frequency counter, and increase the front panel 1,000 Hz oscillator output control until the frequency counter registers a stable, and repetitive count.
6. Adjust R47 to obtain a count of 1,000 Hz, plus or minus 1 Hz.

SINAD SECTION:

7. Push SINAD button.
8. Connect input leads to a 1,000 Hz, 1 Volt Sine Wave Signal with less than 2% distortion. The internal 1,000 Hz section of the LINEAR 5 is a suitable source.
9. Connect a 'scope to the negative of C10, and adjust R14 and R17 for a null in the signal observed on the 'scope. R14 and R17 interlock, and it is necessary to alternately adjust each to get the deepest null.
10. Connect the input to a 2 KHz, 1 Volt signal. Adjust R20 for 200 millivolts RMS at negative side of C10 (.566 volts peak to peak.)
11. Adjust R22 for 0 dB SINAD reading (full scale deflection of the meter).
12. Prepare a 10,000 ohm potentiometer for use as a variable resistor, with suitable test leads. Connect this test resistor between the negative side of C10 and the chassis of the LINEAR 5. Adjust the test resistor until the voltage at C10 is reduced to 12.5 millivolts RMS (35.4 millivolts peak to peak).
13. Adjust R73 to obtain exactly 24 dB SINAD reading on the meter.
14. Remove the shunt variable resistor from C10. Observe that you still have 200 millivolts RMS at C10. Meter should read 0 dB SINAD (full scale on the meter). If not, repeat steps 10, 11, 12 and 13 until both the 0 dB SINAD and 24 dB SINAD readings are correct.

Figure 4

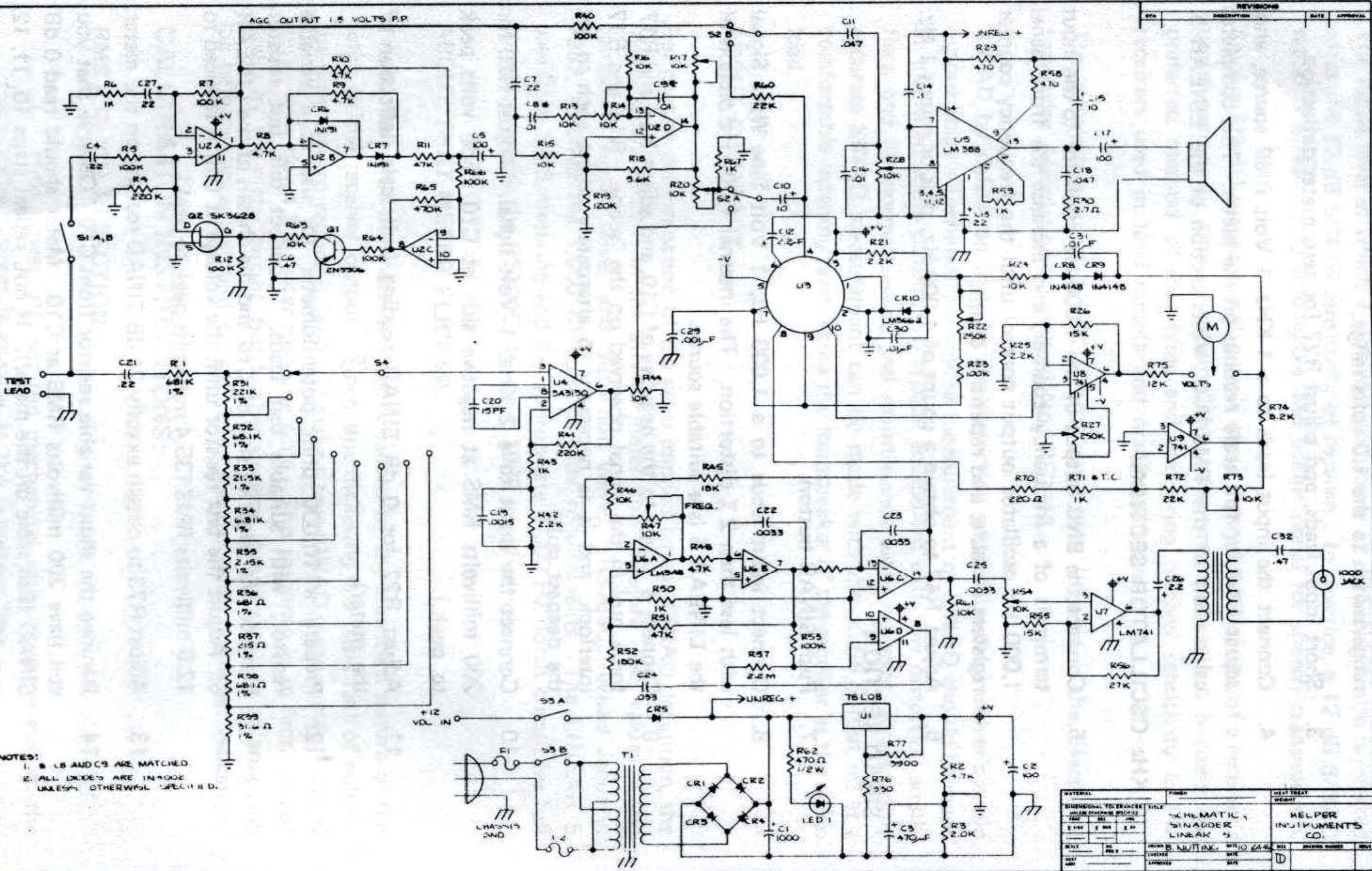

REVISIONS			
REV	DESCRIPTION	DATE	APPROVAL

NOTES:
 1. C8, C9 AND C10 ARE MATCHED
 2. ALL DIODES ARE IN4002 UNLESS OTHERWISE SPECIFIED.

MATERIAL		FINISH		HEAT TREAT	
DIMENSIONAL TOLERANCES UNLESS OTHERWISE SPECIFIED		TITLE		WEIGHT	
FRAC	DEC	SCHEMATIC		HELPER	
1/16	0.001	SINADER		INSTRUMENTS	
1/32	0.0005	LINEAR 5		CO.	
1/64	0.00025	DRAWN BY B. NUTTING		DATE 10/24/62	REV 1
1/128	0.000125	CHECKED	DATE	ISSUED	QUANTITY
1/256	0.0000625	APPROVED	DATE		

Figure 5

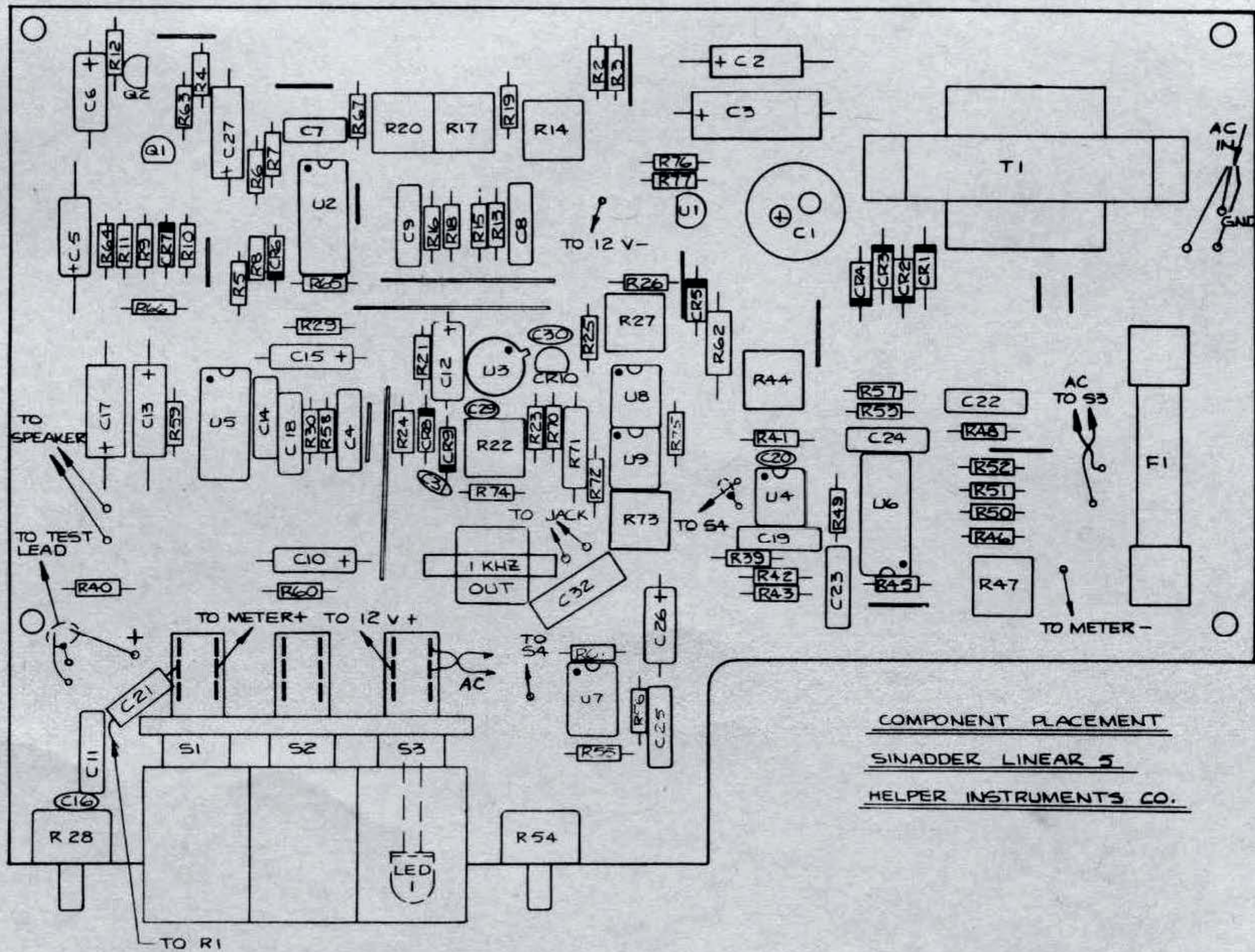

COMPONENT PLACEMENT
SINADDER LINEAR 5
HELPER INSTRUMENTS CO.