

**Tektronix®**

**2235**  
**OSCILLOSCOPE**  
**SERVICE**

INSTRUCTION MANUAL

# Tektronix®

COMMITTED TO EXCELLENCE

## WARNING

THE FOLLOWING SERVICING INSTRUCTIONS ARE FOR USE BY QUALIFIED PERSONNEL ONLY. TO AVOID PERSONAL INJURY, DO NOT PERFORM ANY SERVICING OTHER THAN THAT CONTAINED IN OPERATING INSTRUCTIONS UNLESS YOU ARE QUALIFIED TO DO SO. REFER TO OPERATORS SAFETY SUMMARY AND SERVICE SAFETY SUMMARY PRIOR TO PERFORMING ANY SERVICE.

**Tektronix**  
**National Marketing Center**  
for Product Order Information, call  
**1-800-426-2200 ext 41**

In Oregon call collect (503)627-9000 ext 41

Tektronix National Marketing Center  
P.O. Box 500 D/S Y6-088, Beaverton, OR 97077

**PLEASE CHECK FOR CHANGE INFORMATION  
AT THE REAR OF THIS MANUAL.**

# 2235

## OSCILLOSCOPE

### SERVICE

## INSTRUCTION MANUAL

Tektronix, Inc.  
P.O. Box 500  
Beaverton, Oregon 97077

Serial Number \_\_\_\_\_

070-4206-00  
Product Group 46

First Printing DEC 1982  
Revised MAY 1983

Copyright © 1982 Tektronix, Inc. All rights reserved.  
Contents of this publication may not be reproduced in any  
form without the written permission of Tektronix, Inc.

Products of Tektronix, Inc. and its subsidiaries are covered  
by U.S. and foreign patents and/or pending patents.

TEKTRONIX, TEK, SCOPE-MOBILE, and  are  
registered trademarks of Tektronix, Inc. TELEQUIPMENT  
is a registered trademark of Tektronix U.K. Limited.

Printed in U.S.A. Specification and price change privileges  
are reserved.

### INSTRUMENT SERIAL NUMBERS

Each instrument has a serial number on a panel insert, tag,  
or stamped on the chassis. The first number or letter  
designates the country of manufacture. The last five digits  
of the serial number are assigned sequentially and are  
unique to each instrument. Those manufactured in the  
United States have six unique digits. The country of  
manufacture is identified as follows:

B000000	Tektronix, Inc., Beaverton, Oregon, USA
100000	Tektronix Guernsey, Ltd., Channel Islands
200000	Tektronix United Kingdom, Ltd., London
300000	Sony/Tektronix, Japan
700000	Tektronix Holland, NV, Heerenveen, The Netherlands

# TABLE OF CONTENTS

	Page		Page
<b>LIST OF ILLUSTRATIONS</b> .....	iii	<b>SECTION 3 THEORY OF OPERATION</b>	
<b>LIST OF TABLES</b> .....	iii	INTRODUCTION .....	3-1
<b>OPERATORS SAFETY SUMMARY</b> .....	iv	GENERAL DESCRIPTION .....	3-2
<b>SERVICING SAFETY SUMMARY</b> .....	v	DETAILED CIRCUIT DESCRIPTION	3-3
<b>SECTION 1 SPECIFICATION</b>		VERTICAL ATTENUATORS .....	3-3
INTRODUCTION .....	1-1	Input Coupling .....	3-3
ACCESSORIES .....	1-1	Buffer Amplifier and Gain	
PERFORMANCE CONDITIONS .....	1-1	Switching Network .....	3-4
<b>SECTION 2 OPERATING INSTRUCTIONS</b>		Paraphase Amplifier .....	3-4
PREPARATION FOR USE .....	2-1	VERTICAL PREAMPLIFIERS ...	3-5
SAFETY .....	2-1	CHANNEL SWITCH AND	
LINE VOLTAGE .....	2-1	VERTICAL OUTPUT .....	3-5
POWER CORD .....	2-1	Delay Line Driver .....	3-6
LINE FUSE .....	2-1	Vertical Output Amplifier .....	3-6
INSTRUMENT COOLING .....	2-2	A/B Sweep Separation Circuit .	3-7
CONTROLS, CONNECTORS, AND		TRIGGER AMPLIFIERS AND	
INDICATORS .....	2-2	SWITCHING .....	3-7
POWER, DISPLAY, AND PROBE		Internal Trigger .....	3-7
ADJUST .....	2-2	Internal Trigger Amplifier .....	3-8
VERTICAL .....	2-3	A External Trigger Amplifier ...	3-8
HORIZONTAL .....	2-4	Line Trigger Amplifier .....	3-8
TRIGGER .....	2-6	A TRIGGER GENERATOR .....	3-9
REAR PANEL .....	2-7	A Trigger Level Circuit .....	3-9
OPERATING CONSIDERATIONS ...	2-8	A Trigger Level Comparator ..	3-9
GRATICULE .....	2-8	A Schmitt Trigger and TV	
GROUNDING .....	2-8	Trigger Circuit .....	3-9
SIGNAL CONNECTIONS .....	2-8	A SWEEP GENERATOR AND	
INPUT COUPLING CAPACITOR		LOGIC .....	3-9
PRECHARGING .....	2-8	A Miller Sweep Generator .....	3-10
OPERATOR'S ADJUSTMENTS ....	2-9	A Sweep Logic .....	3-11
INTRODUCTION .....	2-9	ALTERNATE B SWEEP .....	3-11
TRACE ROTATION .....	2-9	B Miller Sweep Generator .....	3-12
PROBE COMPENSATION .....	2-9	B Trigger Level Comparator ..	3-12
OSCILLOSCOPE DISPLAYS .....	2-10	Runs After Delay .....	3-12
INTRODUCTION .....	2-10	B Delay Time Position	
BASELINE TRACE .....	2-10	Comparator .....	3-12
SIGNAL DISPLAY .....	2-11	B Sweep Logic .....	3-12
MAGNIFIED-SWEEP DISPLAY ..	2-11	Alternate Display Switching	
DELAYED-SWEEP DISPLAY .....	2-11	Logic .....	3-13
DELAYED-SWEEP		B Z-Axis Logic .....	3-13
MEASUREMENTS .....	2-11	HORIZONTAL .....	3-13
SINGLE-SWEEP DISPLAY .....	2-12	Horizontal Preamplifier .....	3-14
X-Y DISPLAY .....	2-12	X-Y Amplifier .....	3-14
TV SIGNAL DISPLAYS .....	2-12	Horizontal Output Amplifier ...	3-15
		Z-AXIS AMPLIFIER .....	3-15
		Dc Restorer .....	3-16

# TABLE OF CONTENTS (cont)

	Page		Page
<b>SECTION 3</b>		<b>SECTION 6</b>	
<b>THEORY OF OPERATION (cont)</b>		<b>MAINTENANCE (cont)</b>	
POWER SUPPLY AND PROBE		INTRODUCTION .....	6-2
ADJUST .....	3-17	GENERAL CARE .....	6-2
Power Input .....	3-17	INSPECTION AND CLEANING ..	6-2
Preregulator .....	3-17	LUBRICATION .....	6-4
Inverter .....	3-18	SEMICONDUCTOR CHECKS ...	6-4
Crt Supply .....	3-18	PERIODIC READJUSTMENT ...	6-4
Focus Circuit .....	3-18	TROUBLESHOOTING .....	6-5
Low-Voltage Supplies .....	3-19	INTRODUCTION .....	6-5
Probe Adjust .....	3-19	TROUBLESHOOTING AIDS ....	6-5
		TROUBLESHOOTING	
		EQUIPMENT .....	6-6
		TROUBLESHOOTING	
		TECHNIQUES .....	6-6
<b>SECTION 4</b>		<b>CORRECTIVE MAINTENANCE</b> ....	6-10
<b>PERFORMANCE CHECK</b>		INTRODUCTION .....	6-10
<b>PROCEDURE</b>		MAINTENANCE PRECAUTIONS .	6-10
INTRODUCTION .....	4-1	OBTAINING REPLACEMENT	
PURPOSE .....	4-1	PARTS .....	6-10
STRUCTURE .....	4-1	MAINTENANCE AIDS .....	6-10
TEST EQUIPMENT .....	4-1	INTERCONNECTIONS .....	6-10
LIMITS AND TOLERANCES ....	4-1	TRANSISTORS AND	
PREPARATION FOR CHECKS ..	4-2	INTEGRATED CIRCUITS .....	6-11
INTRODUCTION TO		SOLDERING TECHNIQUES ....	6-12
PERFORMANCE CHECK STEPS	4-3	REMOVAL AND REPLACEMENT	
VERTICAL .....	4-4	INSTRUCTIONS .....	6-13
HORIZONTAL .....	4-8	Cabinet .....	6-13
TRIGGER .....	4-12	Cathode-Ray Tube .....	6-13
EXTERNAL Z-AXIS AND PROBE		Power-Supply Shield .....	6-14
ADJUST .....	4-15	Filter Circuit Board .....	6-14
		Alt Sweep Circuit Board ....	6-15
		Attenuator Circuit Board ....	6-15
		Timing Circuit Board .....	6-16
		Bottom Shield, Attenuator and	
		Timing Circuit-Board Module ..	6-17
		Front-Panel Circuit Board ....	6-17
		Main Circuit Board .....	6-18
		REPACKAGING FOR SHIPMENT	6-20
		SELECTABLE COMPONENTS ..	6-20
<b>SECTION 5</b>		<b>SECTION 7</b>	<b>OPTIONS</b>
<b>ADJUSTMENT PROCEDURE</b>		<b>SECTION 8</b>	<b>REPLACEABLE ELECTRICAL PARTS</b>
INTRODUCTION .....	5-1	<b>SECTION 9</b>	<b>DIAGRAMS</b>
PURPOSE .....	5-1	<b>SECTION 10</b>	<b>REPLACEABLE MECHANICAL PARTS</b>
STRUCTURE .....	5-1	Accessories	
TEST EQUIPMENT .....	5-1		
LIMITS AND TOLERANCES ....	5-1	<b>CHANGE INFORMATION</b>	
ADJUSTMENT INTERACTION ..	5-1		
PREPARATION FOR			
ADJUSTMENT .....	5-1		
INDEX TO ADJUSTMENT			
PROCEDURE STEPS .....	5-3		
POWER SUPPLY AND CRT DISPLAY	5-4		
VERTICAL .....	5-6		
HORIZONTAL .....	5-14		
TRIGGER .....	5-20		
EXTERNAL Z-AXIS AND PROBE			
ADJUST .....	5-24		
<b>SECTION 6</b>			
<b>MAINTENANCE</b>			
STATIC-SENSITIVE COMPONENTS	6-1		
PREVENTIVE MAINTENANCE .....	6-2		

# LIST OF ILLUSTRATIONS

Figure	Page	Figure	Page
	The 2235 Oscilloscope . . . . .	vi	
1-1	Maximum input voltage vs. frequency derating curve for CH 1 OR X, CH 2 OR Y, and EXT INPUT connectors . . . . .	1-7	
2-1	Voltage, power cord, and fuse data . . . . .	2-1	
2-2	Fuse holder and power cord connector . . . . .	2-2	
2-3	Power, display, and probe adjust controls connector and indicator . . . . .	2-3	
2-4	Vertical controls and connectors . . . . .	2-4	
2-5	Horizontal controls . . . . .	2-5	
2-6	Trigger controls, connector, and indicator . . . . .	2-6	
		2-7	Rear-panel connector . . . . .
		2-8	Graticule measurement markings . . . . .
		2-9	Probe compensation . . . . .
		3-1	Block diagram of the Vertical Attenuators . . . . .
		3-2	Block diagram of the Channel Switching circuitry . . . . .
		3-3	Block diagram of the A Sweep Generator and Logic Circuitry . . . . .
		3-4	Block diagram of the Horizontal Amplifier . . . . .
		3-5	Simplified diagram of the Dc Restorer circuitry . . . . .
		6-1	Multi-connector holder orientation . . . . .

# LIST OF TABLES

Table	Page	Table	Page
1-1	Electrical Characteristics . . . . .	1-2	
1-2	Environmental Characteristics . . . . .	1-8	
1-3	Physical Characteristics . . . . .	1-9	
4-1	Test Equipment Required . . . . .	4-2	
4-2	Deflection Accuracy Limits . . . . .	4-4	
4-3	Settings for Bandwidth Checks . . . . .	4-6	
4-4	Settings for Timing Accuracy Checks . . . . .	4-9	
4-5	Settings for Delay Time Accuracy Checks . . . . .	4-10	
4-6	Switch Combinations for A Triggering Checks . . . . .	4-12	
5-1	Adjustment Interactions . . . . .	5-2	
5-2	Power Supply Limits . . . . .	5-4	
5-3	Deflection Accuracy Limits . . . . .	5-8	
		5-4	Attenuator Compensation Adjustments . . . . .
		5-5	Settings for Bandwidth Checks . . . . .
		5-6	Settings for Timing Accuracy Checks . . . . .
		5-7	Settings for Delay Time Accuracy Checks . . . . .
		5-8	Switch Combinations for A Triggering Checks . . . . .
		6-1	Relative Susceptibility to Static-Discharge Damage . . . . .
		6-2	External Inspection Checklist . . . . .
		6-3	Internal Inspection Checklist . . . . .
		6-4	Power Supply Limits and Ripple . . . . .
		6-5	Maintenance Aids . . . . .
		6-6	Trigger Bandwidth Alteration . . . . .

# OPERATORS SAFETY SUMMARY

*The general safety information in this part of the summary is for both operating and servicing personnel. Specific warnings and cautions will be found throughout the manual where they apply and do not appear in this summary.*

## Terms in This Manual

**CAUTION** statements identify conditions or practices that could result in damage to the equipment or other property.

**WARNING** statements identify conditions or practices that could result in personal injury or loss of life.

## Terms as Marked on Equipment

**CAUTION** indicates a personal injury hazard not immediately accessible as one reads the markings, or a hazard to property, including the equipment itself.

**DANGER** indicates a personal injury hazard immediately accessible as one reads the marking.

## Symbols in This Manual



This symbol indicates where applicable cautionary or other information is to be found. For maximum input voltage see Table 1-1.

## Symbols as Marked on Equipment



**DANGER** – High voltage.



Protective ground (earth) terminal.



**ATTENTION** – Refer to manual.

## Power Source

This product is intended to operate from a power source that does not apply more than 250 volts rms between the supply conductors or between either supply conductor and ground. A protective ground connection by way of the grounding conductor in the power cord is essential for safe operation.

## Grounding the Product

This product is grounded through the grounding conductor of the power cord. To avoid electrical shock, plug the power cord into a properly wired receptacle before connecting to the product input or output terminals. A protective ground connection by way of the grounding conductor in the power cord is essential for safe operation.

## Danger Arising From Loss of Ground

Upon loss of the protective-ground connection, all accessible conductive parts (including knobs and controls that may appear to be insulating) can render an electric shock.

## Use the Proper Power Cord

Use only the power cord and connector specified for your product.

Use only a power cord that is in good condition.

For detailed information on power cords and connectors see Figure 2-1.

## Use the Proper Fuse

To avoid fire hazard, use only a fuse of the correct type, voltage rating and current rating as specified in the parts list for your product.

## Do Not Operate in Explosive Atmospheres

To avoid explosion, do not operate this product in an explosive atmosphere unless it has been specifically certified for such operation.

## Do Not Remove Covers or Panels

To avoid personal injury, do not remove the product covers or panels. Do not operate the product without the covers and panels properly installed.

## **SERVICING SAFETY SUMMARY**

### ***FOR QUALIFIED SERVICE PERSONNEL ONLY***

*Refer also to the preceding Operators Safety Summary.*

#### **Do Not Service Alone**

Do not perform internal service or adjustment of this product unless another person capable of rendering first aid and resuscitation is present.

#### **Use Care When Servicing With Power On**

Dangerous voltages exist at several points in this product. To avoid personal injury, do not touch exposed connections or components while power is on.

Disconnect power before removing protective panels, soldering, or replacing components.

#### **Power Source**

This product is intended to operate from a power source that does not apply more than 250 volts rms between the supply conductors or between either supply conductor and ground. A protective ground connection by way of the grounding connector in the power cord is essential for safe operation.

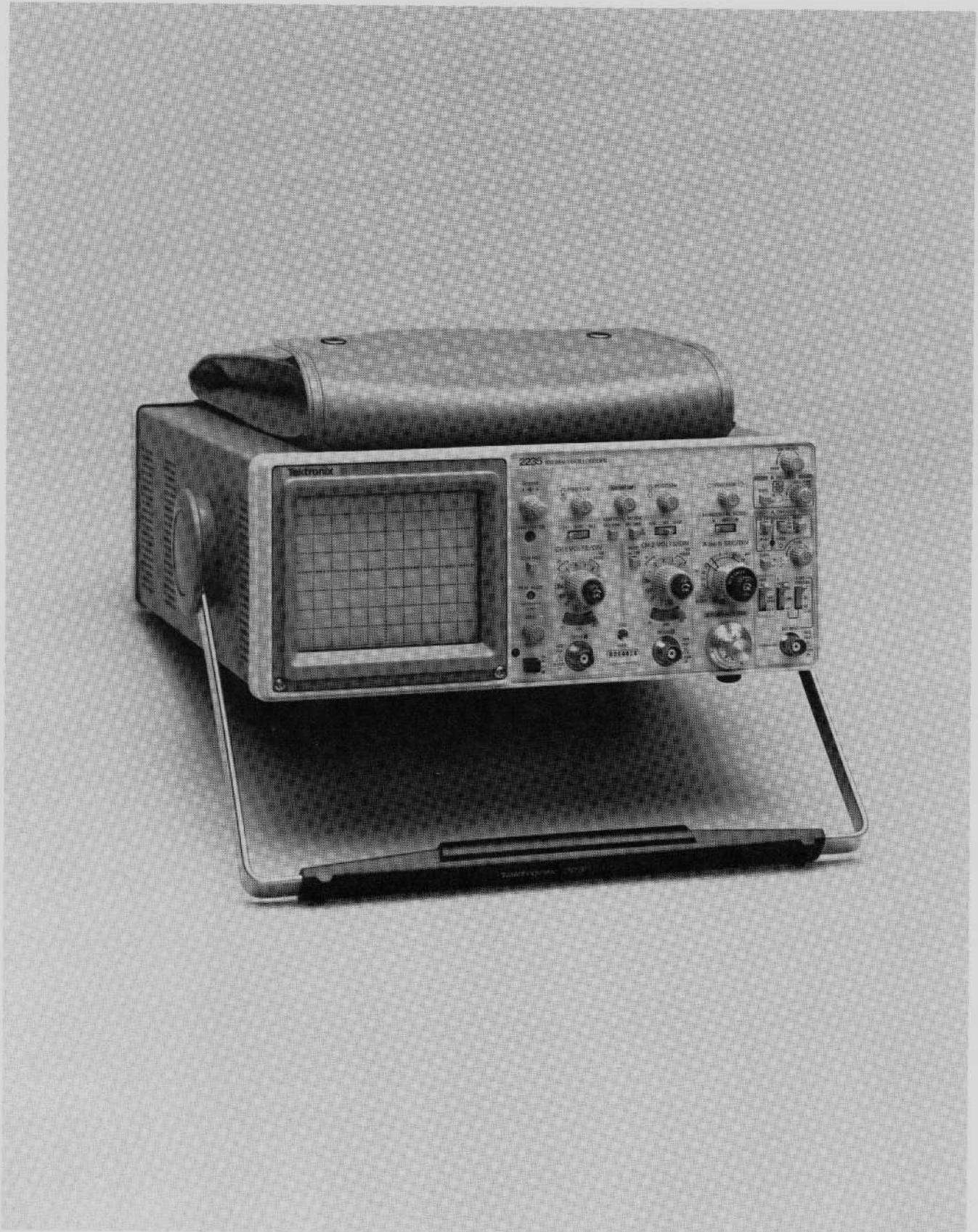

4206-01

The 2235 Oscilloscope

# SPECIFICATION

## INTRODUCTION

The TEKTRONIX 2235 oscilloscope is a rugged, lightweight, dual-channel, 100-MHz instrument that features a bright, sharply defined trace on an 80- by 100-mm cathode-ray tube (crt). Its vertical system provides calibrated deflection factors from 2 mV per division to 5 V per division. Trigger circuits enable stable triggering over the full bandwidth of the vertical system. The horizontal system provides calibrated sweep speeds from 0.5 s per division to 50 ns per division along with delayed-sweep features for accurate relative-time measurements. A X10 magnifier extends the maximum sweep speed to 5 ns per division.

## ACCESSORIES

The instrument is shipped with the following standard accessories:

1 Operators Manual	2 Probe packages
1 Service Manual	

For part numbers and further information about both standard and optional accessories, refer to the "Options and Accessories" section (Section 5) of this manual. Your Tektronix representative, local Tektronix Field Office, or Tektronix product catalog can also provide accessories information.

## PERFORMANCE CONDITIONS

The following electrical characteristics (Table 1-1) are valid for the 2235 when it has been adjusted at an ambient temperature between +20°C and +30°C, has had a warm-up period of at least 20 minutes, and is operating at an ambient temperature between 0°C and +50°C (unless otherwise noted).

Items listed in the "Performance Requirements" column are verifiable qualitative or quantitative limits, while items listed in the "Supplemental Information" column are either explanatory notes, calibration setup descriptions, performance characteristics for which no absolute limits are specified, or characteristics that are impractical to check.

Environmental characteristics are given in Table 1-2. The 2235 meets the requirements of MIL-T-28800C, paragraphs 4.5.5.1.3, 4.5.5.1.4, and 4.5.5.1.2.2 for Type III, Class 5 equipment, except where otherwise noted.

Physical characteristics of the instrument are listed in Table 1-3.

**Table 1-1  
Electrical Characteristics**

Characteristics	Performance Requirements	Supplemental Information
<b>VERTICAL DEFLECTION SYSTEM</b>		
Deflection Factor		
Range	2 mV per division to 5 V per division in a 1-2-5 sequence	5 mV per division to 5 V per division gain is adjusted with VOLTS/DIV switch set to 10 mV per division. 2 mV per division gain is adjusted with VOLTS/DIV switch set to 2 mV per division
Accuracy		
+15°C to +35°C	±2%.	
0°C to +50°C	±3%. <sup>a</sup>	
Range of VOLTS/DIV Variable Control	Continuously variable between settings. Increases deflection factor by at least 2.5 to 1.	
Step Response		Rise time is calculated from the formula: $\frac{0.35}{\text{Bandwidth } (-3 \text{ dB})}$
Rise Time		
0°C to +35°C		
5 mV per Division to 5 V per Division	3.5 ns or less. <sup>a</sup>	
2 mV per Division	3.9 ns or less. <sup>a</sup>	
+35°C to +50°C		
5 mV per Division to 5 V per Division	3.9 ns or less. <sup>a</sup>	
2 mV per Division	4.4 ns or less. <sup>a</sup>	
Aberrations		Measured with 5-division reference signal, centered vertically, from a 50 Ω source driving a 50 Ω coaxial cable terminated in 50 Ω at the input connector with the VOLTS/DIV Variable control in the CAL detent.
Positive-Going Step		
2 mV per Division to 0.5 V per Division	+4%, -4%, 4% p-p.	
1 V per Division to 5 V per Division	+12%, -12%, 12% p-p. <sup>a</sup>	
Bandwidth (-3 dB)		Measured with a vertically centered 6-division reference signal from a 50 Ω source driving a 50 Ω coaxial cable that is terminated in 50 Ω, both at the input connector and at the probe input, with the VOLTS/DIV Variable control in the CAL detent.
0°C to +35°C		
5 mV per Division to 5 V per Division	Dc to at least 100 MHz.	
2 mV per Division	Dc to at least 90 MHz.	
+35°C to +50°C		
5 mV per Division to 5 V per Division.	Dc to at least 90 MHz. <sup>a</sup>	
2 mV per Division	Dc to at least 80 MHz. <sup>a</sup>	
AC Coupled Lower Limit	10 Hz or less at -3 dB. <sup>a</sup>	

<sup>a</sup>Performance Requirement not checked in Service Manual.

Table 1-1 (cont)

Characteristics	Performance Requirements	Supplemental Information
<b>VERTICAL DEFLECTION SYSTEM</b>		
Bandwidth Limiter	Upper limits ( $-3$ dB) bandpass at 20 MHz $\pm 10\%$ .	
Chop Mode Switching Rate	500 kHz $\pm 30\%$ . <sup>a</sup>	
Input Characteristics		
Resistance	1 M $\Omega$ $\pm 2\%$ . <sup>a</sup>	
Capacitance	20 pF $\pm 2$ pF. <sup>a</sup>	
Maximum Safe Input Voltage 	See Figure 1-1 for derating curve.	
DC Coupled	400 V (dc + peak ac) or 800 V ac p-p to 10 kHz or less. <sup>a</sup>	
AC Coupled	400 V (dc + peak ac) or 800 V ac p-p to 10 kHz or less. <sup>a</sup>	
Common-Mode Rejection Ratio (CMRR)	At least 20 to 1 at 50 MHz.	Checked at 10 mV per division for common-mode signals of 6 divisions or less with VOLTS/DIV Variable control adjusted for best CMRR at 50 kHz.
Input Current	1.0 nA or less (0.5 division trace shift at 2 mV per division). <sup>a</sup>	
Trace Shift with Attenuator Rotation	0.75 division or less. <sup>a</sup>	VOLTS/DIV Variable control in CAL detent.
Trace Shift as VOLTS/DIV Variable Control is Rotated	1.0 division or less. <sup>a</sup>	
Trace Shift with Invert	1.5 division or less. <sup>a</sup>	
Channel Isolation	Greater than 100 to 1 at 50 MHz.	
POSITION Control Range	At least $\pm 11$ division from graticule center.	

<sup>a</sup>Performance Requirement not checked in Service Manual.

Table 1-1 (cont)

Characteristics	Performance Requirements	Supplemental Information
<b>TRIGGER SYSTEM</b>		
A TRIGGER Sensitivity		External trigger signal from a 50 Ω source driving a 50 Ω coaxial cable terminated in 50 Ω at the input connector.
P-P AUTO and NORM/TV LINE Modes	<b>10 MHz    60 MHz    100 MHz</b>	
Internal	0.3 div    1.0 div    1.5 div	
External	35 mV    120 mV    200 mV	
Lowest Useable Frequency in P-P AUTO Mode	20 Hz with 1.0 division internal or 100 mV external. <sup>a</sup>	
TV FIELD Mode	1.0 division of composite sync. <sup>a</sup>	
B TRIGGER Sensitivity (Internal Only)	<b>10 MHz    60 MHz    100 MHz</b>	
	0.3 div    1.0 div    1.5 div	
EXT INPUT		
Maximum Input Voltage 	400 V (dc + peak ac) or 800 V ac p-p at 10 kHz or less (see Figure 1-1). <sup>a</sup>	
Input Resistance	1 MΩ ± 2%. <sup>a</sup>	
Input Capacitance	20 pF ± 2.5 pF. <sup>a</sup>	
AC Coupled	10 Hz or less at lower -3 dB point. <sup>a</sup>	
LEVEL Control Range		
A TRIGGER (NORM)		
INT	Can be set to any point of the trace that can be displayed. <sup>a</sup>	
EXT, DC	At least ±1.6 V, 3.2 V p-p.	
EXT, DC ÷ 10	At least ±16 V, 32 V p-p. <sup>a</sup>	
B TRIGGER		
Internal	Can be set to any point of the trace that can be displayed. <sup>a</sup>	
VAR HOLDOFF Control	Increases A Sweep holdoff time by at least a factor of 10. <sup>a</sup>	
Trigger View System		
Deflection Factor		
Internal	Same as vertical.	
External		
AC and DC	100 mV per division.	
DC ÷ 10	1 V per division.	
Accuracy	± 20%.	
Delay Difference Between EXT INPUT and Either Vertical Channel	Less than 2.0 ns. <sup>a</sup>	

<sup>a</sup>Performance Requirement not checked in Service Manual.

Table 1-1 (cont)

Characteristics	Performance Requirements	Supplemental Information
<b>HORIZONTAL DEFLECTION SYSTEM</b>		
Sweep Rate		
Calibrated Range		
A Sweep	0.5 s per division to 0.05 $\mu$ s per division in a 1-2-5 sequence. X10 magnifier extends maximum sweep speed to 5 ns per division.	
B Sweep	50 ms per division to 0.05 $\mu$ s per division in a 1-2-5 sequence. X10 magnifier extends maximum sweep speed to 5 ns per division.	
Accuracy	<b>Unmagnified</b> <b>Magnified</b>	Sweep accuracy applies over the center 8 divisions. Exclude the first 25 ns of the sweep for magnified sweep speeds and anything beyond the 100th magnified division.
+15°C to +35°C	± 2%      ± 3%	
0°C to +50°C	± 3% <sup>a</sup> ± 4% <sup>a</sup>	
POSITION Control Range	Start of sweep to 10th division will position past the center vertical graticule line in X1 or 100th division in X10.	
Sweep Linearity	± 5%.	Linearity measured over any 2 of the center 8 divisions. With magnifier in X10, exclude the first 25 ns and anything past the 100th division.
Variable Control Range	Continuously variable between calibrated settings. Extends the A and B sweep speeds by at least a factor of 2.5.	
Sweep Length	Greater than 10 division.	
A/B SWP SEP Range	± 3.5 divisions or greater.	
Delay Time	Applies to 0.5 $\mu$ s per division and slower.	Delay time is functional but not calibrated at sweep settings above 0.5 $\mu$ s per division.
Dial Control Range	<0.5 +300 ns to >10 divisions.	
Jitter	One part or less in 20,000 (0.005%) of the maximum available delay time.	
Differential Time Measurement Accuracy		Exclude delayed operation when A and B SEC/DIV knobs are locked together at any sweep speed or when A SEC/DIV switch is at 0.5 $\mu$ s per division or faster. Accuracy applies over the B DELAY TIME POSITION control range.
+15°C to +35°C	± 1% +0.015 major dial division	
0°C to +50°C	± 2% +0.015 major dial division. <sup>a</sup>	

<sup>a</sup>Performance Requirement not checked in Service Manual.

Table 1-1 (cont)

Characteristics	Performance Requirements	Supplemental Information
<b>X-Y OPERATION (X1 MAGNIFICATION)</b>		
Deflection Factors	Same as Vertical Deflection System (with VOLTS/DIV Variable controls in CAL detent).	
Accuracy		Measured with a dc-coupled, 5-division reference signal.
X-Axis		
+15°C to +35°C	±3%.	
0°C to +50°C	±4%. <sup>a</sup>	
Y-Axis	Same as Vertical Deflection System. <sup>a</sup>	
Bandwidth (−3 dB)		Measured with a 5-division reference signal.
X-Axis	Dc to at least 3 MHz.	
Y-Axis	Same as Vertical Deflection System. <sup>a</sup>	
Phase Difference Between X- and Y-Axis Amplifiers	±3° from dc to 150 kHz. <sup>a</sup>	With dc-coupled inputs.
<b>PROBE ADJUST</b>		
Output Voltage of PROBE ADJUST Jack	0.5 V ±5%.	
Repetition Rate	1 kHz ±20%. <sup>a</sup>	
<b>Z-AXIS INPUT</b>		
Sensitivity	5 V causes noticeable modulation. Positive-going input decreases intensity.	Useable frequency range is dc to 20 MHz.
Maximum Safe Input Voltage	30 V (dc + peak ac) or 30 VC p-p ac at 1 kHz or less. <sup>a</sup>	
Input Resistance	10 kΩ ±10%. <sup>a</sup>	
<b>POWER SOURCE</b>		
Line Voltage Ranges	90 V to 250 V. <sup>a</sup>	
Line Frequency	48 Hz to 440 Hz. <sup>a</sup>	
Maximum Power Consumption	40 W (70 VA). <sup>a</sup>	
Line Fuse	1.0 A, 250 V, slow-blow.	
<b>CATHODE-RAY TUBE</b>		
Display Area	80 by 100 mm. <sup>a</sup>	
Standard Phosphor	P31. <sup>a</sup>	
Nominal Accelerating Voltage	14 kV. <sup>a</sup>	

<sup>a</sup>Performance Requirement not checked in Service Manual.

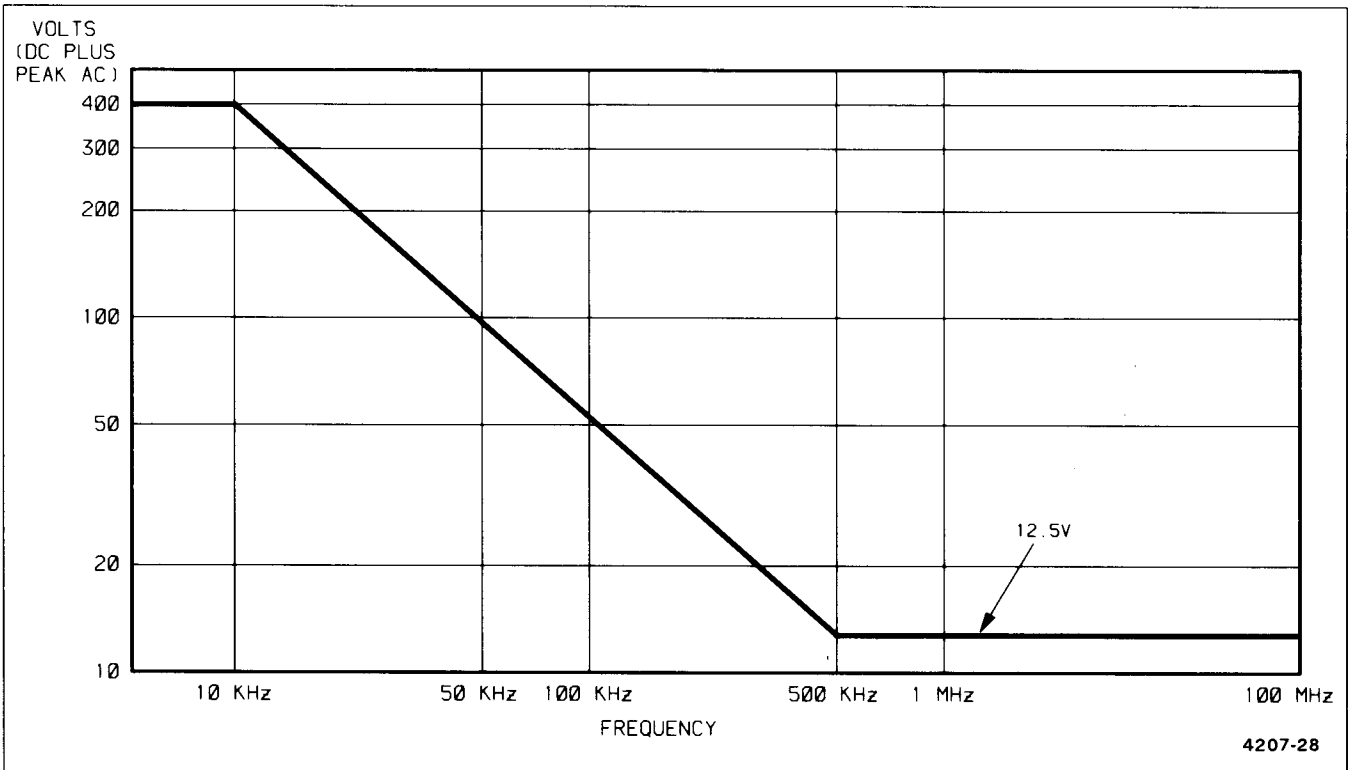

Figure 1-1. Maximum input voltage vs. frequency derating curve for CH 1 OR X, CH 2 OR Y, and EXT INPUT connectors.

**Table 1-2  
Environmental Characteristics**

Characteristics	Description
	<p style="text-align: center;">NOTE</p> <p><i>The instrument meets the requirements of MIL-T-28800C, paragraphs 4.5.5.1.3, 4.5.5.1.4, and 4.5.5.1.2.2 for Type III, Class 5 equipment, except where otherwise noted.</i></p>
Temperature	
<p>Operating</p> <p>Nonoperating</p>	<p>0°C to +50°C (+32°F to +122°F).</p> <p>–55°C to +75°C (–67°F to +167°F). Tested to MIL-T-28800C paragraphs 4.5.5.1.3 and 4.5.5.1.4, except in 4.5.5.1.3 steps 4 and 5 (0°C operating test) are performed ahead of step 2 (–55°C nonoperating test). Equipment shall remain off upon return to room ambient during step 6. Excessive condensation shall be removed before operating during step 7.</p>
Altitude	
<p>Operating</p> <p>Nonoperating</p>	<p>To 4,500 m (15,000 ft). Maximum operating temperature decreased 1°C per 1,000 ft above 5,000 ft.</p> <p>To 15,000 m (50,000 ft).</p>
Humidity (Operating and Nonoperating)	<p>5 cycles (120 hours) referenced to MIL-T-28800C paragraph 4.5.5.1.2.2 for Type III, Class 5 instruments. Operating and non-operating at 95% +0% to –5% relative humidity. Operating at +50°C and +30°C. Non-operating at +30°C to +60°C.</p>
Vibration (Operating)	<p>15 minutes along each of 3 major axes at a total displacement of 0.015 inch p-p (2.4 g's at 55 Hz) with frequency varied from 10 Hz to 55 Hz to 10 Hz in 1-minute sweeps. Hold for 10 minutes at 55 Hz in each of the 3 major axes. All major resonances must be above 55 Hz.</p>
Shock (Operating and Nonoperating)	<p>30 g's, half-sine, 11-ms duration, 3 shocks per axis each direction, for a total of 18 shocks.</p>
EMI	<p>Meets radiated and conducted emission requirements per VDE 0871 Class B.</p>

**Table 1-3  
Physical Characteristics**

<b>Characteristics</b>	<b>Description</b>
Weight With Power Cord	
With Cover, Probes, and Pouch	7.1 kg (15.7 lb).
Without Cover, Probes, and Pouch	6.1 kg (13.5 lb).
Domestic Shipping Weight	8.2 kg (18.0 lb).
Height	
With Feet and Handles	137 mm (5.4 in).
Width	
With Handle	360 mm (14.2 in).
Without Handle	327 mm (12.9 in).
Depth	
With Front Cover	445 mm (17.5 in).
Without Front Cover	440 mm (17.3 in).
With Handle Extended	511 mm (20.1 in).

# OPERATING INSTRUCTIONS

## PREPARATION FOR USE

### SAFETY

Refer to the "Operators Safety Summary" at the front of this manual for power source, grounding, and other safety considerations pertaining to the use of the 2235. Before connecting the instrument to a power source, carefully read the following information about line voltage, power cord, and fuse.

### LINE VOLTAGE

This instrument is capable of continuous operation with input voltages that range from 90 V to 250 V nominal at frequencies from 48 Hz to 440 Hz.

### POWER CORD

A detachable three-wire power cord with a three-contact plug is provided with each instrument to permit connection to both the power source and protective ground. The protective-ground contact in the plug connects (through the protective-ground conductor) to the accessible metal parts of the instrument. For electrical-shock protection, insert this plug only into a power-source outlet that has a properly grounded protective-ground contact.

Instruments are shipped with the required power cord as ordered by the customer. Available power-cord information is presented in Figure 2-1, and part numbers are listed on the "Accessories" page at the back of this manual. Contact your Tektronix representative or local Tektronix Field Office for additional power-cord information.

### LINE FUSE

The instrument fuse holder is located on the rear panel (see Figure 2-2) and contains the line fuse. The following procedure can be used to verify that the proper fuse is installed or to install a replacement fuse.





Plug Configuration	Usage	Line Voltage	Reference Standards	Option Number
	North American 120V/ 15A	120V	ANSI C73.11 NEMA 5-15-P IEC 83	Standard
	Universal Euro 240V/ 10-16A	240V	CEE (7),II,IV,VII IEC 83	A1
	UK 240V/ 13A	240V	BS 1363 IEC 83	A2
	Australian 240V/ 10A	240V	AS C112	A3
	North American 240V/ 15A	240V	ANSI C73.20 NEMA 6-15-P IEC 83	A4
	Switzerland 220V/ 6A	220V	SEV	A5
Abbreviations: ANSI — American National Standards Institute AS — Standards Association of Australia BS — British Standards Institution CEE — International Commission on Rules for the Approval of Electrical Equipment IEC — International Electrotechnical Commission NEMA — National Electrical Manufacturer's Association SEV — Schweizerischer Elektrotechnischer Verein				2931-21

Figure 2-1. Voltage, power cord, and fuse data.

1. Unplug the power cord from the power-input source (if applicable).
2. Press in and slightly rotate the fuse-holder cap counterclockwise to release it.
3. Pull the cap (with the attached fuse inside) out of the fuse holder.
4. Verify proper fuse value (see Figure 2-1).

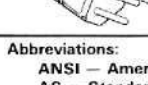
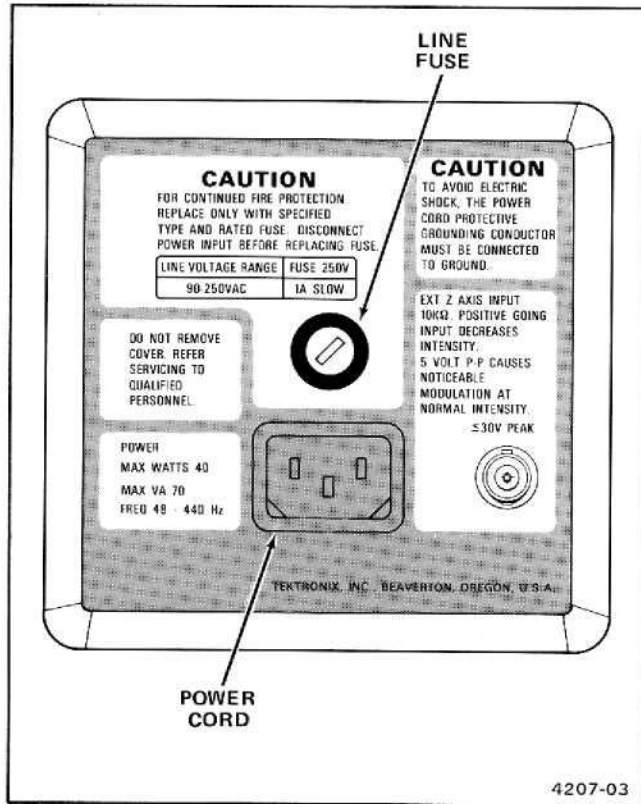

Figure 2-2. Fuse holder and power cord connector.

5. Reinstall the fuse (or replacement fuse) and the fuse-holder cap.

## INSTRUMENT COOLING

Always maintain adequate instrument cooling. The ventilation holes on both side of the equipment cabinet and on the rear panel must remain free of obstructions.

# CONTROLS, CONNECTORS, AND INDICATORS

The following descriptions are intended to familiarize the operator with the location, operation, and function of the instrument's controls, connectors, and indicators.

## POWER, DISPLAY, AND PROBE ADJUST

Refer to Figure 2-3 for location of items 1 through 8.

- 1 Internal Graticule—Eliminates parallax viewing error between the trace and graticule lines. Rise-time amplitude and measurement points are indicated at the left edge of the graticule.
- 2 POWER Switch—Turns instrument power on and off. Press in for ON; press again for OFF.
- 3 Power Indicator—An LED that illuminates when power is available to the instrument and the POWER switch is set to ON (button in).
- 4 FOCUS Control—Adjusts for optimum display definition.
- 5 PROBE ADJUST Connector—Provides an approximately 0.5 V, negative-going, square-wave voltage (at approximately 1 kHz) that permits an operator to compensate voltage probes and the check operation of the oscilloscope vertical system. It is not intended to verify the accuracy of the vertical gain or time-base circuitry.
- 6 BEAM FIND Switch—When held in, compresses the display to within the graticule area and provides a visible viewing intensity to aid in locating off-screen displays.
- 7 TRACE ROTATION Control—Screwdriver adjustment used to align the crt trace with the horizontal graticule lines.

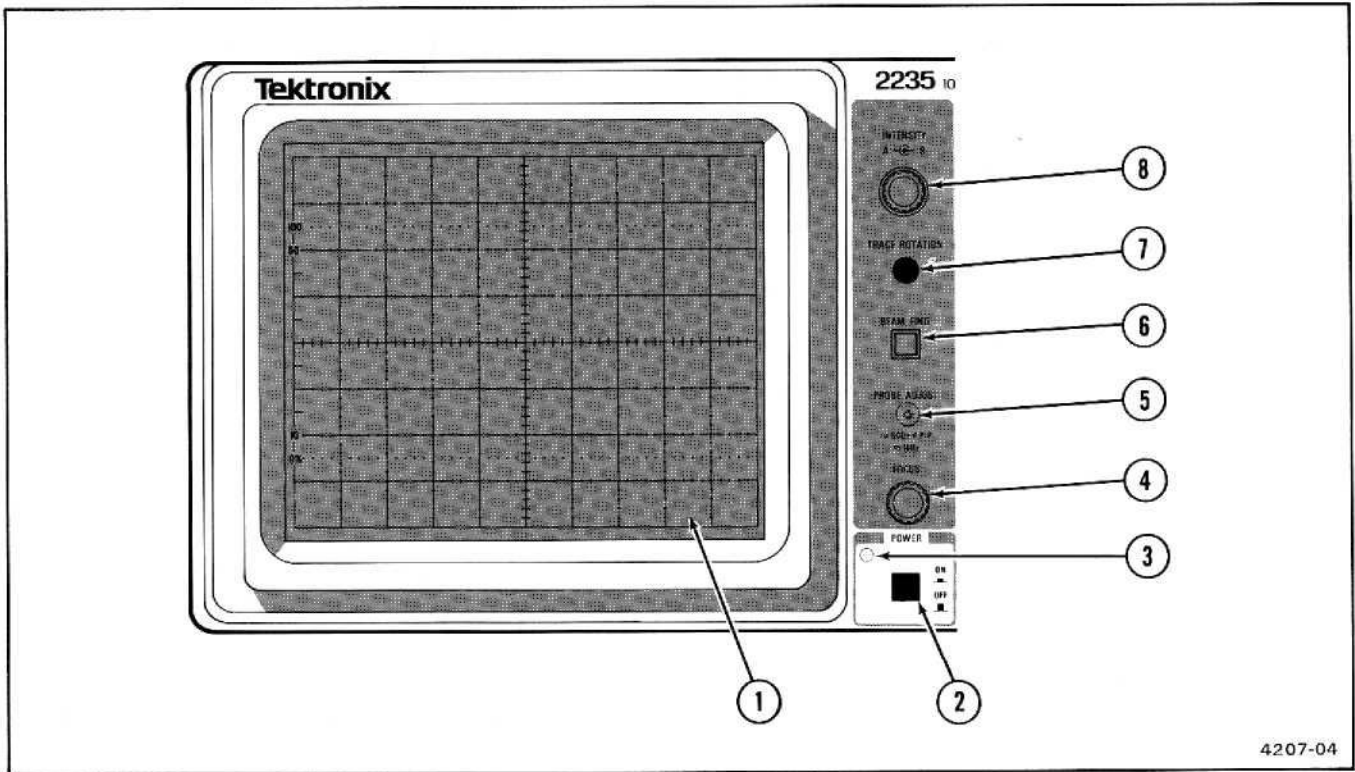

Figure 2-3. Power, display, and probe adjust controls, connector, and indicator.

- 8 A and B INTENSITY Controls—Determine the brightness of the A and the B Sweep traces.

### VERTICAL

Refer to Figure 2-4 for location of items 9 through 18.

- 9 CH 1 VOLTS/DIV and CH 2 VOLTS/DIV Switches—Used to select the vertical deflection factor in a 1-2-5 sequence. To obtain a calibrated deflection factor, the VOLTS/DIV variable control must be in the calibrated (CAL) detent (fully clockwise).

1X—Indicates the deflection factor selected when using either a 1X probe or a coaxial cable.

10X PROBE—Indicates the deflection factor selected when using a 10X probe.

- 10 VOLTS/DIV Variable Controls—When rotated counterclockwise out of their calibrated detent positions, these controls provide continuously variable, uncalibrated deflection factors between the calibrated settings of the VOLTS/DIV switches.

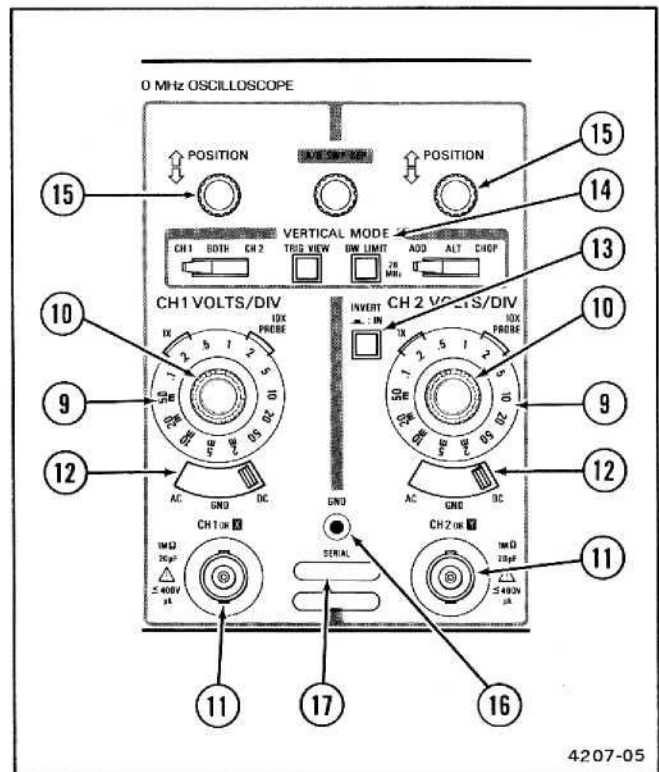

Figure 2-4. Vertical controls and connectors.

⑪ CH 1 OR X and CH 2 OR Y Connectors—Provide for application of external signals to the inputs of the vertical deflection system or for an X-Y display. In the X-Y mode, the signal connected to the CH 1 OR X connector provides horizontal deflection, and the signal connected to the CH 2 OR Y connector provides vertical deflection.

⑫ Input Coupling (AC-GND-DC) Switches—Used to select the method of coupling input signals to the vertical deflection system.

AC—Input signal is capacitively coupled to the vertical amplifier. The dc component of the input signal is blocked. Low-frequency limit (–3 Db point) is approximately 10 Hz.

GND—The input of the vertical amplifier is grounded to provide a zero (ground) reference-voltage display (does not ground the input signal). This switch position allows precharging the input coupling capacitor.

DC—All frequency components of the input signal are coupled to the vertical deflection system.

⑬ INVERT Switch—Inverts the Channel 2 display when button is pressed in. Push button must be pressed in a second time to release it and regain a noninverted display.

⑭ VERTICAL MODE Switches—Two three-position switches and two push-button switches are used to select the mode of operation for the vertical amplifier system.

CH 1—Selects only the Channel 1 input signal for display.

BOTH—Selects both Channel 1 and Channel 2 input signals for display. The BOTH position must be selected for either ADD, ALT, or CHOP Operation.

CH 2—Selects only the Channel 2 input signal for display.

ADD—Displays the algebraic sum of the Channel 1 and Channel 2 input signals.

ALT—Alternately displays Channel 1 and Channel 2 input signals. The Alteration occurs during retrace at the end of each sweep. This mode is useful for viewing both input signals at sweep speeds from 0.05  $\mu$ s per division to 0.2 ms per division.

CHOP—The display switches between the Channel 1 and Channel 2 input signals during the

sweep. The switching rate is approximately 500 kHz. This mode is useful for viewing both Channel 1 and Channel 2 input signals at sweep speeds from 0.5 ms per division to 0.5 s per division.

TRIG VIEW—Press in and hold this push button to display a sample of the signal present in the A Trigger amplifier (for all A SOURCE switch settings). All other signal displays are removed while the TRIG VIEW Push button is held in.

BW LIMIT—When pressed in, this push-button switch limits the bandwidth of the vertical amplifier and the A Trigger system to approximately 20 MHz. Push button must be pressed a second time to release it and regain full 100 MHz bandwidth operation. Provides a method for reducing interference from high-frequency signals when viewing low-frequency signals.

⑮ POSITION Controls—Used to vertically position the display on the crt. When the SEC/DIV switch is set to X-Y, the Channel 2 POSITION control moves the display vertically (Y-axis), and the Horizontal POSITION control moves the display horizontally (X-axis).

⑯ GND Connector—Provides direct connection to the instrument chassis ground.

⑰ SERIAL and Mod Slots—The SERIAL slot is imprinted with the instrument's serial number. The Mod slot contains any option number that is installed in the instrument.

## HORIZONTAL

Refer to Figure 2-5 for location of items 18 through 24.

⑱ A and B SEC/DIV Switches—Used to select the sweep speeds for the A and B Sweep Generator in a 1-2-5 sequence. To obtain calibrated sweep speeds, the A and B SEC/DIV Variable control must be in the calibrated detent (fully clockwise).

A SEC/DIV—The calibrated sweep speed is shown between the two black lines on the clear plastic skirt. This switch also selects the delay time for delayed-sweep operation when used in conjunction with the B DELAY TIME POSITION control.

B SEC/DIV—The B-Sweep speed is set by pulling out the (DLY'D SWEEP PULL) knob and rotating it clockwise to a setting opposite the white line scribed on the knob. The B Sweep circuit is used only for delayed-sweep operation.

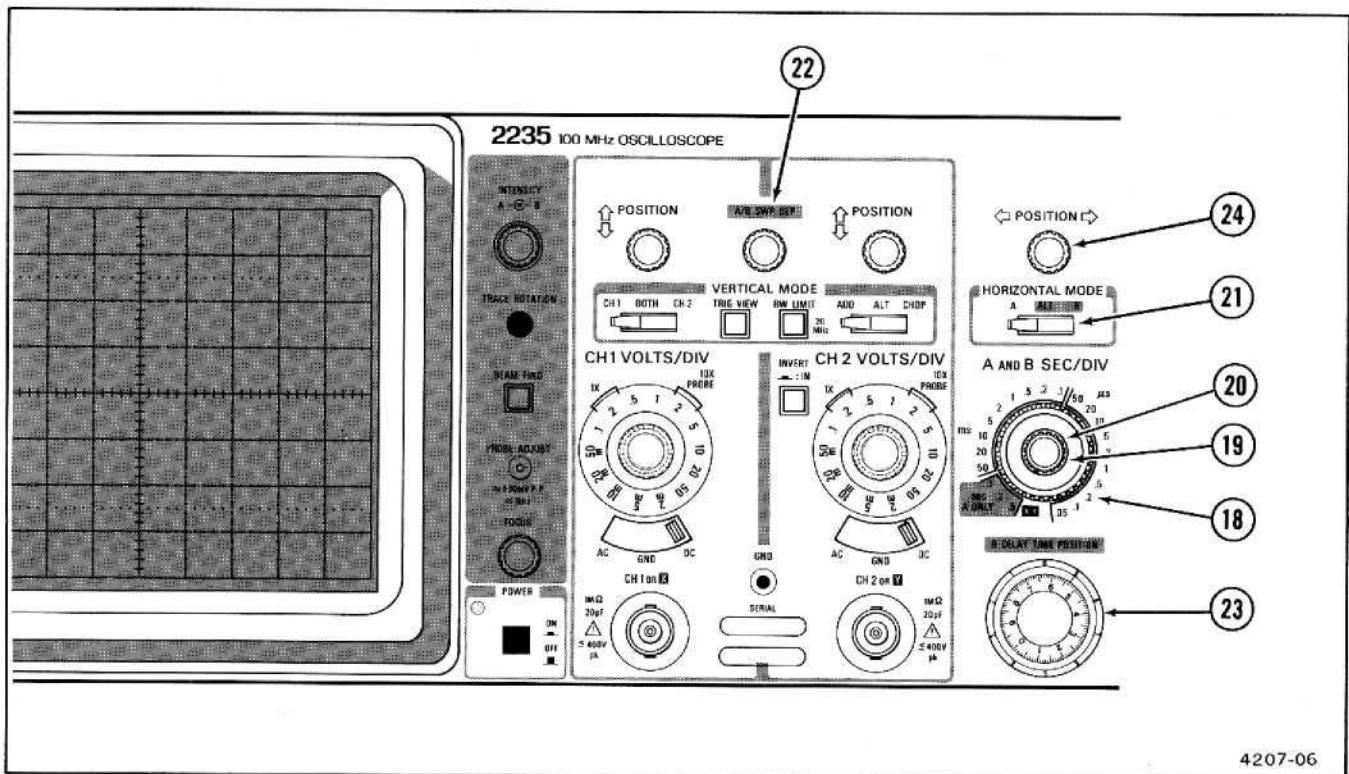

Figure 2-5. Horizontal controls.

- 19 A and B SEC/DIV Variable Control—Provides continuously variable, uncalibrated A Sweep speeds to at least 2.5 times the calibrated setting. It extends the slowest sweep speed to at least 1.25 s per division.
- 20 X10 Magnifier Switch—To increase displayed sweep speed by a factor of 10, pull out the A and B SEC/DIV Variable knob. The fastest sweep speed can be extended to 5 ns per division. Push in the A and B SEC/DIV Variable knob to regain the X1 sweep speed.
- 21 HORIZONTAL MODE Switch—This three-position switch determines the mode of operation for the horizontal deflection system.
- A—Horizontal deflection is provided by the A Sweep generator at a sweep speed determined by the A SEC/DIV switch setting.
- ALT—Alternates the horizontal displays between the A Sweep (with an intensified zone) and the B Delayed Sweep. The A Sweep speed is determined by the setting of the A SEC/DIV switch. The B Sweep speed and the length of the intensified zone on the A Sweep are both determined by the B SEC/DIV switch setting.
- B—Horizontal deflection is provided by the B Sweep generator at a sweep speed determined by the B SEC/DIV switch setting. The start of the B Sweep is delayed from the start of the A Sweep by a time determined by the settings of both the A SEC/DIV switch and the B DELAY TIME POSITION control.
- 22 A/B SWP SEP Control—Vertically positions the B Sweep trace with respect to the A Sweep trace when ALT HORIZONTAL MODE is selected.
- 23 B DELAY TIME POSITION Control—Selects the amount of delay time between the start of the A Sweep and the start of the B Sweep. Delay time is variable from 0.5 times to 10 times the A SEC/DIV switch setting.
- 24 POSITION Control—Horizontally positions both the A Sweep and the B Sweep displays and horizontally positions X-axis in the X-Y mode.

## TRIGGER

Refer to Figure 2-6 for locations of items 25 through 34.

- 25 TRIGGER Mode Switches—Three push-button switches that determine the trigger mode for the A Sweep.

**SGL SWP RESET**—Press in the spring-return push button momentarily to arm the A Sweep circuit for a single-sweep display. This mode operates the same as NORM, except only one sweep is displayed for each trigger signal. Another sweep cannot be displayed until the SGL SWP RESET Push button is momentarily pressed in again to reset the A Sweep circuit. This mode is useful for displaying and photographing either nonrepetitive signals or signals that cause unstable conventional displays (e.g., signals that vary in amplitude, shape, or time).

**P-P AUTO-TV LINE**—Permits triggering on waveforms having repetition rates of at least 20 Hz and television lines. Sweep free-runs in the absence of an adequate trigger signal or when the repetition rate is below 20 Hz. The range of the A TRIGGER LEVEL control is restricted to the peak-to-peak range of the trigger signal.

**NORM**—Sweep is initiated when an adequate trigger signal is applied. In the absence of a trigger signal, no baseline trace will be present.

**TV FIELD**—Press in both P-P AUTO and NORM push buttons. Permits triggering on television field signals.

- 26 TRIG'D READY Indicator—The LED illuminates when either the P-P AUTO or the NORM Trigger Mode is selected to indicate that the A Sweep is triggered (TRIG'D). When the SGL SWP RESET button is momentarily pressed in, the LED illuminates to indicate that the A Trigger circuit is armed (READY) for a single-sweep display.

- 27 A TRIGGER LEVEL Control—Selects the amplitude point on the trigger signal at which the sweep is triggered.

- 28 SLOPE Switches—Select the slope of the signal that triggers the sweep.

**OUT**—When push button is released out, sweep is triggered from the positive-going slope of the trigger signal.

**IN**—When push button is pressed in, sweep is triggered from the negative-going slope of the trigger signal.

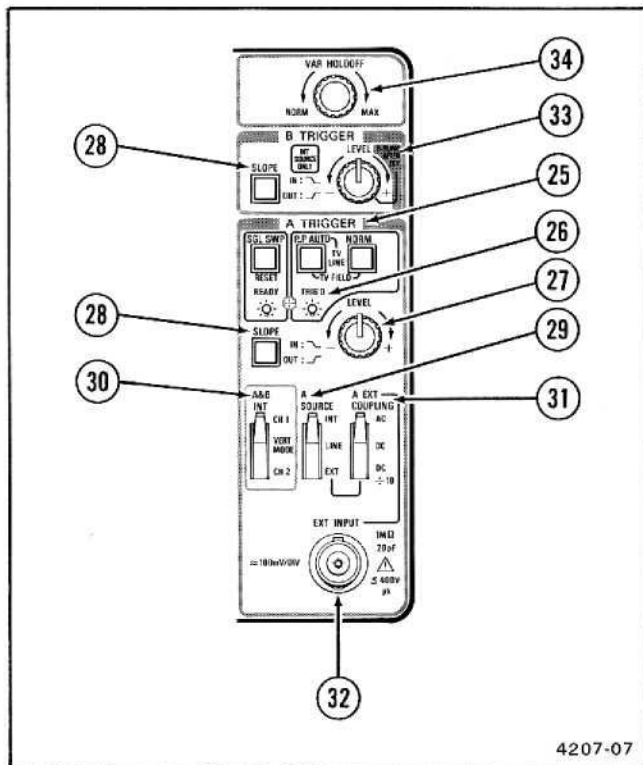

Figure 2-6. Trigger controls, connector, and indicator.

- 29 A SOURCE Switch—Determines the source of the trigger signal that is coupled to the input of the A Trigger circuit.

**INT**—Permits triggering on signals that are applied to the CH 1 OR X and CH 2 OR Y input connectors. The source of the internal signal is selected by the A & B INT switch.

**LINE**—Selects the power-source waveform as the source of the trigger signal. This trigger source is useful when vertical-input signals are time related (multiple or submultiple) to the frequency of the power-source voltage.

**EXT**—Permits triggering on signals applied to the EXT INPUT connector.

- 30 A & B INT Switch—Selects the source of the internal trigger signal when the A SOURCE switch is set to INT.

**CH 1**—The signal applied to the CH 1 OR X input connector is the source of the trigger signal.

**VERT MODE**—The internal trigger source is determined by the signals selected for display by the VERTICAL MODE switches.

**CH 2**—The signal applied to the CH 2 OR Y input connector is the source of the trigger signal.

- 31 A EXT COUPLING Switch—Determines the method used to couple external signals to the A Trigger circuit from the EXT INPUT connector.

**AC**—Signals above 60 Hz are capacitively coupled to the input of the A Trigger circuit. Any dc components are blocked, and signals below 60 Hz are attenuated.

**DC**—All components of the signal are coupled to the input of the A Trigger circuitry. This position is useful for displaying low-frequency or low-repetition-rate signals.

**DC ÷ 10**—External trigger signals are attenuated by a factor of 10. All components of the signal are coupled to the input of the A Trigger circuit.

- 32 EXT INPUT Connector—Provides a means of introducing external signals into the A Trigger circuit through the A EXT COUPLING switch.

- 33 B TRIGGER LEVEL Control—Selects the amplitude point on the trigger signals at which the sweep is triggered. When fully clockwise; (B RUNS AFTER DLY), the B Sweep circuit runs immediately following the delay time selected by the A SEC/DIV switch and the B DELAY TIME POSITION control.

- 34 VAR HOLDOFF control—Provides continuous control of holdoff time between sweeps. Increases the holdoff time by at least a factor of 10. This control improves the ability to trigger on aperiodic signals (such as complex digital waveforms).

## REAR PANEL

Refer to Figure 2-7 for location of item 35.

- 35 EXT Z-AXIS Connector—Provides a means of connecting external signals to the Z-axis amplifier to intensity modulate the crt display. Applied signals do not affect display waveshape. Signals with fast rise times and fall times provide the most abrupt intensity change, and a 5 V p-p signal will produce noticeable modulation. The Z-axis signals must be time-related to the display to obtain a stable presentation on the crt.

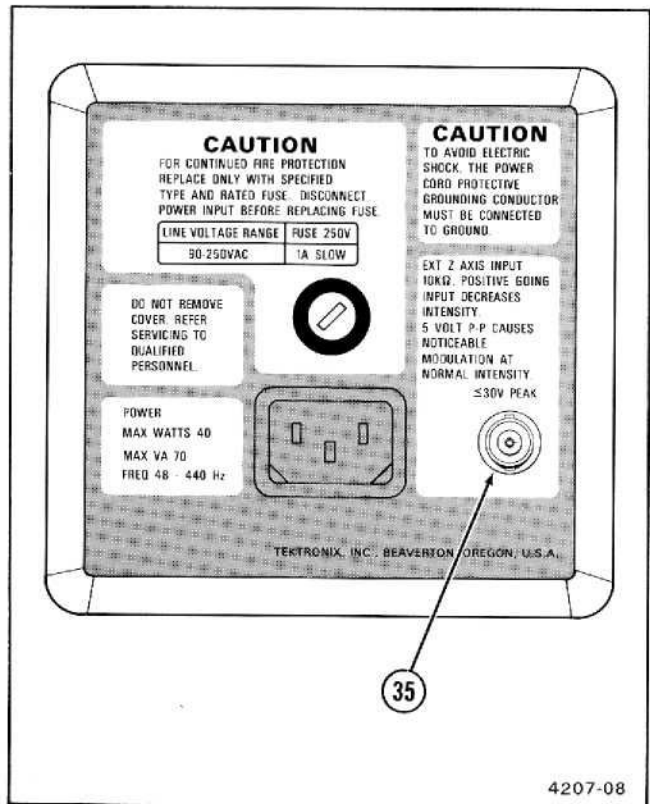

Figure 2-7. Rear-panel connector.

## OPERATING CONSIDERATIONS

The following basic operating information and techniques should be considered before attempting to make any measurements with your instrument.

### GRATICULE

The graticule is internally marked on the faceplate of the crt to enable accurate measurements without parallax error (see Figure 2-8). It is marked with eight vertical and ten horizontal major divisions. Each major division is divided into five subdivisions. The vertical deflection factors and horizontal timing are calibrated to the graticule so that accurate measurements can be made directly from the crt. Also, percentage markers for the measurement of rise and fall times are located on the left side of the graticule.

### GROUNDING

The most reliable signal measurements are made when the 2235 and the unit under test are connected by a common reference (ground lead), in addition to the signal lead or probe. The probe's ground lead provides the best grounding method for signal interconnection and ensures the maximum amount of signal-lead shielding in the probe cable. A separate ground lead can also be connected from the unit under test to the oscilloscope GND connector located on the front panel.

### SIGNAL CONNECTIONS

Generally, probes offer the most convenient means of connecting an input signal to the instrument. They are shielded to prevent pickup of electromagnetic interference, and the supplied 10X probe offers a high input impedance that minimizes circuit loading. This allows the circuit under test to operate with a minimum of change from its normal condition as measurements are being made.

Coaxial cables may also be used to connect signals to the input connectors, but they may have considerable effect on the accuracy of a displayed waveform. To maintain the original frequency characteristics of an applied signal, only high-quality, low-loss coaxial cables should be used. Coaxial cables should be terminated at both ends in their characteristic impedance. If this is not possible, use suitable impedance-matching devices.

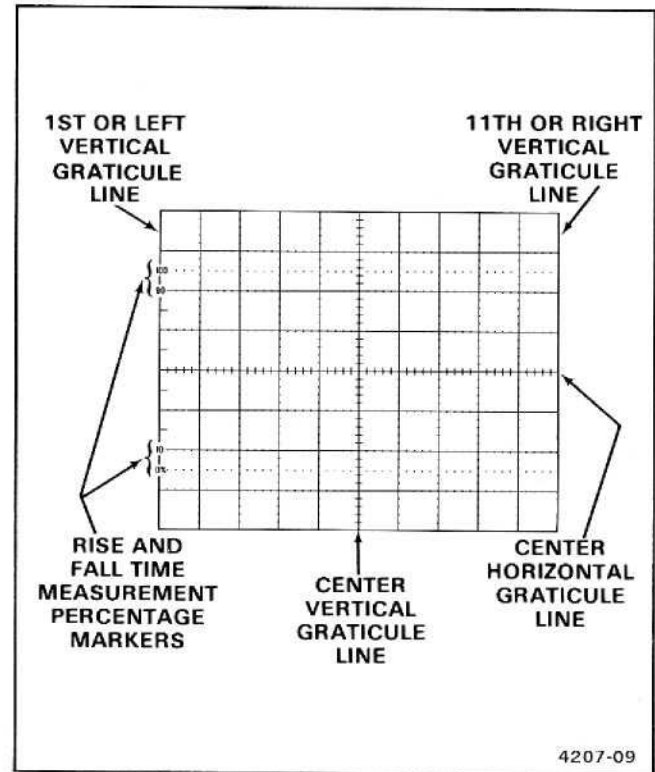

Figure 2-8. Graticule measurement markings.

### INPUT COUPLING CAPACITOR PRECHARGING

When the input coupling switch is set to GND, the input signal is connected to ground through the input coupling capacitor in series with a 1 MΩ resistor to form a precharging network. This network allows the input coupling capacitor to charge to the average dc-voltage level of the signal applied to the probe. Thus any large voltage transients that may accidentally be generated will not be applied to the amplifier input when the input coupling switch is moved from GND to AC. The precharging network also provides a measure of protection to the external circuitry by reducing the current levels that can be drawn from the external circuitry during capacitor charging.

The following procedure should be used whenever the probe tip is connected to a signal source having a different dc level than that previously applied, especially if the dc-

level difference is more than 10 times the VOLTS/DIV switch setting:

1. Set the AC-GND-DC switch to GND.
2. Insert the probe tip into the oscilloscope GND connector and wait several seconds for the input coupling capacitor to discharge.

3. Connect the probe tip to the signal source and wait several seconds for the input coupling capacitor to charge.

4. Set the AC-GND-DC switch to AC. The display will remain on the screen, and the ac component of the signal can be measured in the normal manner.

## OPERATOR'S ADJUSTMENTS

### INTRODUCTION

Two adjustments should be performed before making measurements with your oscilloscope: Trace Rotation and Probe Compensation. Before starting either of these adjustments, set the instrument controls and obtain a baseline trace as described under "Baseline Trace" on the next page. Allow the instrument to warm up for at least 20 minutes when specified in the procedure.

### TRACE ROTATION

1. Use the Channel 1 POSITION control to move the baseline trace to the center horizontal graticule line.

#### NOTE

*Normally, the resulting trace will be parallel to the center horizontal graticule line, and the Trace Rotation adjustment should not be required.*

2. If the resulting trace is not parallel to the center horizontal graticule line, use small flat-bit screwdriver to adjust the TRACE ROTATION control and align the trace with the center horizontal graticule line.

### PROBE COMPENSATION

Misadjustment of probe compensation is one of the source of measurement error. Most attenuator probes are equipped with a compensation adjustment. To ensure optimum measurement accuracy, always compensate the oscil-

loscope probes before making measurements. Probe compensation is accomplished as follows:

1. Connect the two 10X probes (supplied with the instrument) to the CH 1 and CH 2 input connectors.

2. Set both VOLTS/DIV switches to 0.1 (10X PROBE) and set both AC-GND-DC switches to DC.

3. Select CH 1 VERTICAL MODE and insert the tip of the Channel 1 probe into the PROBE ADJUST output jack.

4. Obtain a display of the PROBE ADJUST signal (approximately 1 kHz square-wave) by following steps 3 through 6 under "Signal Display" on the next page.

5. Check the waveform presentation for overshoot and rolloff (see Figure 2-9). If necessary, adjust the probe compensation for flat tops on the waveforms. Refer to the instructions supplied with the probe for details of compensation adjustment.

6. Disconnect the Channel 1 probe tip, select CH 2 VERTICAL MODE, and connect the Channel 2 probe tip to the PROBE ADJUST Output jack.

7. Repeat steps 4 and 5 for the Channel 2 probe.

8. Disconnect the Channel 2 probe tip.

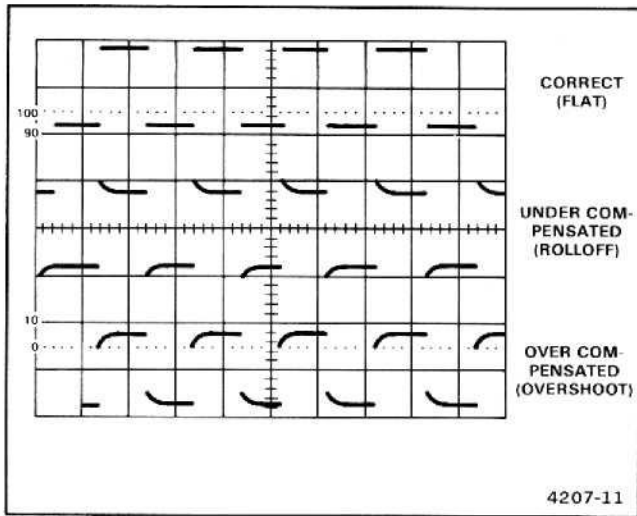

Figure 2-9. Probe compensation.

## OSCILLOSCOPE DISPLAYS

### INTRODUCTION

The procedure in this section will allow you to set up and operate your instrument to obtain the most commonly used oscilloscope display.

### BASELINE TRACE

1. Set the instrument front-panel controls as follows:

#### Display

INTENSITY	As desired
FOCUS	Best focused display

#### Vertical (Both Channels)

POSITION	Midrange
VERTICAL MODE	CH 1
BW LIMIT	Off (button out)
VOLTS/DIV	50 m
VOLTS/DIV Variable	CAL detent
INVERT	Off (button out)
AC-GND-DC	AC

#### Horizontal

A/B SWP SEP	Off midrange
POSITION	Midrange
HORIZONTAL MODE	A
A and B SEC/DIV	0.5 ms
SEC/DIV Variable	CAL detent
X10 Magnifier	Off (knob in)
B DELAY TIME POSITION	Fully counterclockwise

#### B TRIGGER

SLOPE	OUT
LEVEL	Fully clockwise

#### A TRIGGER

VAR HOLDOFF	NORM
Mode	P-P AUTO
SLOPE	OUT
LEVEL	Midrange
A&B INT	VERT MODE
A SOURCE	INT
A EXT COUPLING	AC

2. Press in the POWER switch button (on) and allow the instrument to warm up or at least 20 minutes.

3. Adjust the A INTENSITY control for desired display brightness.

4. Adjust both the Vertical and Horizontal POSITION controls to center the trace on the screen.

## SIGNAL DISPLAY

1. Obtain a baseline trace.

2. Apply a signal to either vertical-channel input connector and set the VERTICAL MODE switch to display the channel used. To display two time-related input signal, use both vertical-channel input connectors and select BOTH VERTICAL MODE; then select either ALT or CHOP, depending on the frequency of input signals.

3. Adjust the A INTENSITY control for desired display brightness. If the display is not visible with the INTENSITY control at midrange, press the BEAM FIND push button and hold it in while adjusting the appropriate VOLTS/DIV switch(es) to reduce the vertical display size. Center the compressed display within the graticule area using the Vertical and Horizontal POSITION control, then release the BEAM FIND push button.

4. Adjust the A TRIGGER LEVEL control, if necessary, to obtain a stable display.

5. Set the appropriate VOLTS/DIV switch(es) and readjust the Vertical and Horizontal POSITION controls to center the display within the graticule area.

6. Set the A SEC/DIV switch to display several cycles of the displayed signal. Then adjust the FOCUS control for the best-defined display.

## MAGNIFIED-SWEEP DISPLAY

1. Obtain a Signal Display (see preceding instructions).

2. Adjust the Horizontal POSITION control to move the trace area that is to be magnified to the center of the crt graticule (0.5 division on each side of the center vertical graticule line). Change the A SEC/DIV switch setting as required.

3. Pull out the SEC/DIV Variable knob (X10) to obtain sweep magnification.

4. Adjust the Horizontal POSITION control for precise positioning of the magnified display.

5. To calculate the magnified sweep speed, divide the A SEC/DIV switch setting by 10.

## DELAYED-SWEEP DISPLAY

1. Obtain a Signal Display.

2. Select ALT HORIZONTAL MODE. Adjust the A and B INTENSITY controls for desired display brightness.

3. Adjust the appropriate channel POSITION control and the A/B SWP SEP control to display the A trace above the B trace.

4. Adjust the A INTENSITY control as needed to make the intensified zone distinguishable from the remainder of the display. Set the B SEC/DIV switch until the intensified zone is the desired length.

5. Adjust the B DELAY TIME POSITION control to move the intensified zone to cover that portion of the A trace that is to be displayed on the B trace. The B HORIZONTAL MODE may be used to display the intensified portion of the A Sweep.

## DELAYED-SWEEP MEASUREMENTS

1. Obtain a Signal Display.

2. Select ALT HORIZONTAL MODE. Adjust the A and B INTENSITY controls for desired display brightness.

3. Adjust the appropriate channel POSITION control and the A/B SWP SEP control to display the A trace above the B trace.

4. Adjust the A INTENSITY control as needed to make the intensified zone distinguishable from the remainder of the display. Set the B SEC/DIV switch until the intensified zone is the desired length.

## Operating Instructions—2235 Service

5. Adjust the B DELAY TIME POSITION control to move the intensified zone to the leading edge of the first pulse of interest; then fine adjust until the rising portion is centered at any convenient vertical graticule line.

6. Record the B DELAY TIME POSITION control dial setting.

7. Adjust the B DELAY TIME POSITION control clockwise until the rising portion of the second pulse of interest is positioned to the same vertical reference line selected in step 5.

8. Record the B DELAY TIME POSITION control dial setting.

9. Use the following formula to calculate the time difference:

$$\text{Time Difference (delayed sweep)} = \left( \begin{array}{cc} \text{second dial} & \text{first dial} \\ \text{setting} & \text{setting} \end{array} \right) \left( \begin{array}{c} \text{A SEC/DIV} \\ \text{switch setting} \\ \text{(delay time)} \end{array} \right)$$

## SINGLE-SWEEP DISPLAY

1. Obtain a Signal Display.

2. For random signals, set the A TRIGGER LEVEL control to trigger the sweep on a signal that is approximately the same amplitude as the random signal.

3. Momentarily press in the A TRIGGER SGL SWP RESET push button. If no trigger signal is present, the TRIG'D-READY light should illuminate to indicate that the A Sweep Generator circuit is set to initiate a sweep when a trigger signal is received. The next trigger pulse will initiate the sweep, and a single trace will be displayed.

4. When the single sweep is triggered and the sweep completed, the Sweep-Logic circuitry is then locked out. Another sweep cannot be generated until the SGL SWP RESET push button is again pressed in to set the A Sweep Generator to the READY condition.

## X-Y DISPLAY

1. Obtain a baseline trace.

2. Use equal-length coaxial cables, or the two 10X probes supplied with the instrument, to apply the horizontal signal (X-axis) to the CH 1 OR X input connector and to apply the vertical signal (Y-axis) to the CH 2 OR Y input connector.

3. Select X-Y mode by rotating the A SEC/DIV switch to its fully counterclockwise position.

4. Rotate the A INTENSITY control clockwise until two dots are displayed. The display can be positioned horizontally with the Horizontal POSITION control and vertically with the Channel 2 POSITION control.

### NOTE

*The display obtained when sinusoidal signals are applied to the X- and Y-axis is called a Lissajous figure. This display is commonly used to compare the frequency and phase relationships of two input signals. The frequency relationship of the two input signals determines the pattern seen. The pattern will be stable only if a common divisor exists between the two frequencies.*

## TV SIGNAL DISPLAYS

### Displaying a TV Line-rate Signal

1. Display of the desired TV signal (see "Signal Display" procedure).

2. Set the A SEC/DIV control to 10  $\mu$ s, and the A & B INT switch either to CH 1 or to CH 2, as appropriate for the applied signal.

3. Set the A TRIGGER SLOPE switch either for a positive-going signal (lever up, if the applied TV signal sync pulses are positive-going) or for a negative-going signal (lever down, if the TV sync pulses are negative-going).

4. Adjust the A TRIGGER LEVEL control for a stable display, and the A INTENSITY control for desired display brightness. If necessary, adjust the VERTICAL VOLTS/DIV control to obtain a trace having 5 divisions or greater amplitude with a stable display.

### NOTE

*To examine a TV Line-rate signal in more detail, either the X10 Magnifier or HORIZONTAL MODE functions may be employed as previously described in this manual.*

### Displaying a TV Field-rate Signal

1. Obtain a Signal Display of the desired TV signal (see "Signal Display" procedure).

2. Set the following controls:

A SEC/DIV	2 ms
A TRIGGER Mode	TV FIELD
A & B INT	Either CH 1 or CH 2, appropriate

3. Perform Steps 3 and 4 under the preceding "Displaying a TV Line-rate Signal" procedure.

4. To display either Field 1 or Field 2 individually at faster sweep rates (displays or less than one full field), set VERTICAL MODE to BOTH and ALT simultaneously. This synchronizes the Channel 1 display to one field and the Channel 2 display to the other field.

To change the field that is displayed, interrupt the triggering either by repeatedly setting the AC-GND-DC switch to GND or by disconnecting and reconnecting the signal from the input connector until the other field is displayed. To display both fields simultaneously, apply the input signal to both the CH 1 and CH 2 inputs, using either two probes, two cables, or a dual-input coupler.

#### NOTE

*To examine a TV Field-rate signal in more detail, either the X10 Magnifier or HORIZONTAL MODE functions may be employed as previously described in the subsection of the manual.*

5. To display a selected horizontal line, first trigger the sweep on a vertical (field rate) sync pulse, then use the delayed sweep to delay out to that line for close examination. This procedure is useful for examining VITS signals.

# THEORY OF OPERATION

## INTRODUCTION

### SECTION ORGANIZATION

This section of the manual contains a general summary of instrument functions followed by a detailed description of each major circuit. A basic block diagram, a detailed block diagram, and the schematic diagrams are located in the tabbed "Diagrams" section at the back of this manual. They are used to show the interconnections between parts of the circuitry, to indicate circuit components, and to identify interrelationships with the front-panel controls.

The schematic diagram number associated with each description is identified in the text and is shown on the block diagrams. For best understanding of the circuit being described, refer to the appropriate schematic diagram and the two block diagrams.

### INTEGRATED CIRCUIT DESCRIPTIONS

#### Digital Logic Conventions

Digital logic circuits perform many functions within the instrument. Functions and operation of the logic circuits are represented by logic symbology and terminology. Most logic functions are described using the positive-logic convention. Positive logic is a system of notation whereby the more positive of two levels is the TRUE (or 1) state; the more negative level is the FALSE (or 0) state. In this logic description the TRUE state is referred to as HI, and the FALSE state is referred to as LO. The specific voltages which constitute a HI or a LO state vary between specific devices. For specific device characteristics, refer to the manufacturer's data book.

#### Linear Devices

The functioning of individual linear circuit devices in this section use waveforms or other techniques such as voltage measurement and simplified diagrams to illustrate their operation.

## GENERAL DESCRIPTION

### NOTE

*When reading this general circuit description of the 2235 Oscilloscope, refer to the basic block diagram (Figure 9-4) and to the detailed block diagram (Figure 9-5) located in the "Diagrams" section of this manual. In Figures 9-4 and 9-5, the numbered diamond symbol in each major block refers to the appropriate schematic diagram number.*

Signals to be displayed on the crt are applied to either the CH 1 OR X input connector or the CH 2 OR Y input connector. These signals may be directly (DC) coupled to the Attenuator circuit or ac (AC) coupled through an input-coupling capacitor. The input signals may also be disconnected from the oscilloscope circuitry and the input attenuator grounded by setting the coupling switch to the GND position.

The output signal from the Attenuator circuit is applied to the Vertical Preamplifier for further amplification. Additionally, the Channel 2 Attenuator can invert the Channel 2 display on the crt. Trigger Pickoff Amplifiers in each channel supply an internal trigger signal from either or both channels to the Internal Trigger Amplifier.

Input signals are selected for display by the Channel Switching circuit under control of the front-panel VERTICAL MODE switches. The output signal from the Channel Switching circuit is applied to a Diode Gate circuit to enable either the vertical or trigger view signal to drive the Delay Line Driver stage. This stage converts a current input to a voltage output and provides an impedance match for the Delay Line. The Delay Line produces approximately 90 ns of delay in the vertical signal. This allows the Horizontal circuitry time to start the sweep so that the operator can see the signal that triggered the sweep.

Final amplification of the vertical signal is performed by the Vertical Output Amplifier. This Amplifier supplies the signal levels necessary for vertical deflection of the electron beam in the crt. The upper frequency response of the Amplifier can be reduced by enabling the Bandwidth Limit circuitry. For locating the position of off-screen displays, the dynamic range of the Amplifier can be limited with the Beam Find circuitry. This circuitry also intensifies the trace and limits horizontal deflection.

The A/B Sweep Separation circuitry supplies a dc-offset current to the Vertical Output Amplifier which vertically posi-

tions the B trace with respect to the A trace when Alt Horizontal Mode is selected.

The A Trigger circuitry uses either an Internal Trigger signal, an External Trigger signal, or a Line Trigger signal obtained from the ac power line to develop the gate signal for the A Sweep Generator. The B Trigger circuitry uses only the Internal Trigger signal to gate the B Sweep Generator. A P-P Auto Trigger circuit ensures that the range of the A TRIGGER LEVEL control tracks the peak-to-peak amplitude of the trigger signal when either the P-P Auto or TV Field trigger mode is selected. This allows triggering on most signals without needing to adjust the A TRIGGER LEVEL control. In Norm mode, the A TRIGGER LEVEL control must be adjusted for the correct trigger signal level before a sweep can be generated. When the TRIG VIEW switch is activated, the signal appearing at the input of the A Trigger circuit is applied to the Delay Line Driver and displayed on the crt.

A TV Field sync circuit provides stable triggering on television vertical-sync pulses. Triggering at the television line rate is accomplished when either P-P Auto or Norm mode is selected.

The A Sweep Logic circuit controls sweep generation and Z-Axis unblanking for the A Sweep display. When the A TRIGGER Mode switches are set to either P-P AUTO or TV FIELD and no trigger signal is present, the Auto Baseline circuit causes the Sweep Logic circuit to produce a sweep for reference purposes. In the NORM setting, the Auto Baseline circuit is disabled and sweeps are inhibited until a trigger event occurs. This is useful for triggering on low-repetition-rate signals. The SGL SWP setting enables only one sweep to be generated after being reset. Following the single sweep, the A Trigger circuit is disabled until the SGL SWP button is pressed again.

The A Sweep Logic circuit controls the operation of the A Miller Sweep Generator circuit. The Sweep circuit produces a linear sweep output with a ramp time that is controlled by the A SEC/DIV switch. The sweep signal is applied to the Horizontal Preamplifier for initial amplification and then to the Horizontal Output Amplifier to drive the crt horizontal deflection plates.

The Horizontal Preamplifier gain is increased by a factor of 10 when the X10 Magnifier is used. Horizontal positioning of the display is accomplished in the Horizontal Preamplifier circuit.

In the X-Y mode of operation, the Channel 1 signal from the Internal Trigger circuitry passes through the X-Y Amplifier to the Horizontal Preamplifier. In this operating mode, the Channel 1 Internal Trigger signal supplies the horizontal deflection to the crt, and the Miller Sweep circuit is disabled to inhibit sweep generation.

The Alternate B Sweep circuitry controls the Alt and B Horizontal mode displays and includes the B Miller Sweep Generator and B Sweep Logic circuitry. In addition to providing the B Sweep sawtooth waveform, signals are generated which control the display switching between the A and B displays.

The intensity levels of both the A and B Sweeps are set by the front-panel A and B INTENSITY controls. These controls, along with signals from the A and B Sweep Logic circuits, determine the drive level to the Z-Axis Amplifier.

The Z-Axis drive from both the A Sweep Logic circuit and the Alternate B Sweep circuit is applied to the Z-Axis Amplifier. The output signal from the Z-Axis Amplifier circuit sets the crt intensity. When using Chop Vertical mode, a blanking

signal from the Chop Oscillator circuit blanks the crt display while switching between the vertical channels.

The Dc Restorer circuit applies the output voltage of the Z-Axis Amplifier between the cathode and grid of the crt. High dc potentials on these elements prohibit direct coupling to the crt.

The Power Supply provides the necessary operating voltages for the instrument. Operating potentials are obtained from a circuit composed of the Preregulator, Inverter and Transformer, and Rectifiers and Filters. The Preregulator produces approximately +43 V dc from the ac power line which is used to drive the 20 kHz Inverter stage. The transformer secondary windings provide various ac levels that are rectified and filtered to produce the operating voltages. A high-voltage multiplier circuit produces the accelerating, focus, and cathode potentials required by the crt.

A front-panel PROBE ADJUST output is provided for use in adjusting probe compensation. The voltage at the PROBE ADJUST connector is a negative-going square wave that has a peak-to-peak amplitude of approximately 0.5 V and a repetition rate of approximately 1 kHz.

## DETAILED CIRCUIT DESCRIPTION

### VERTICAL ATTENUATORS

The Channel 1 and Channel 2 Attenuator circuits, shown on Diagram 1, are identical with the exception of the additional Invert circuitry in the Channel 2 Paraphase Amplifier. Therefore, only the Channel 1 Attenuator will be described and the Invert circuitry of Channel 2 will be discussed separately.

The Attenuator circuit (see Figure 3-1) provides control of input coupling, vertical deflection factor, and variable volts-per-division gain. Input signals for crt vertical deflection may be connected to the CH 1 OR X and the CH 2 OR Y input connectors. In the X-Y mode of operation, the signal applied to the CH 1 OR X connector provides horizontal (X-Axis) deflection for the display, and the signal applied to the CH 2 OR Y connector provides the vertical (Y-Axis) deflection for the display.

### Input Coupling

The signal applied to the CH 1 OR X input connector can be ac coupled, dc coupled, or disconnected from the input of the High-Impedance Input Attenuator circuit. Signals applied to the CH 1 OR X input connector are routed through resistor R9100 to Input Coupling switch S1. When S1 is set for dc coupling, the Channel 1 signal is applied directly to the input of the High-Impedance Attenuator stage. When ac coupled, the input signal passes through dc-blocking capacitor C2. The blocking capacitor prevents the dc component of the input signal from being applied to the Attenuator circuit. When switched into the signal path, attenuators AT1 and AT2 attenuate the input signal by factors of 100 and 10 respectively. When S1 is set to GND, the direct signal path is opened and the input of the Buffer Amplifier is connected to ground. This provides a ground reference without the need to disconnect the applied signal from the input connector. The coupling capacitor precharges through R4 to prevent large trace shifts when switching from GND to AC.

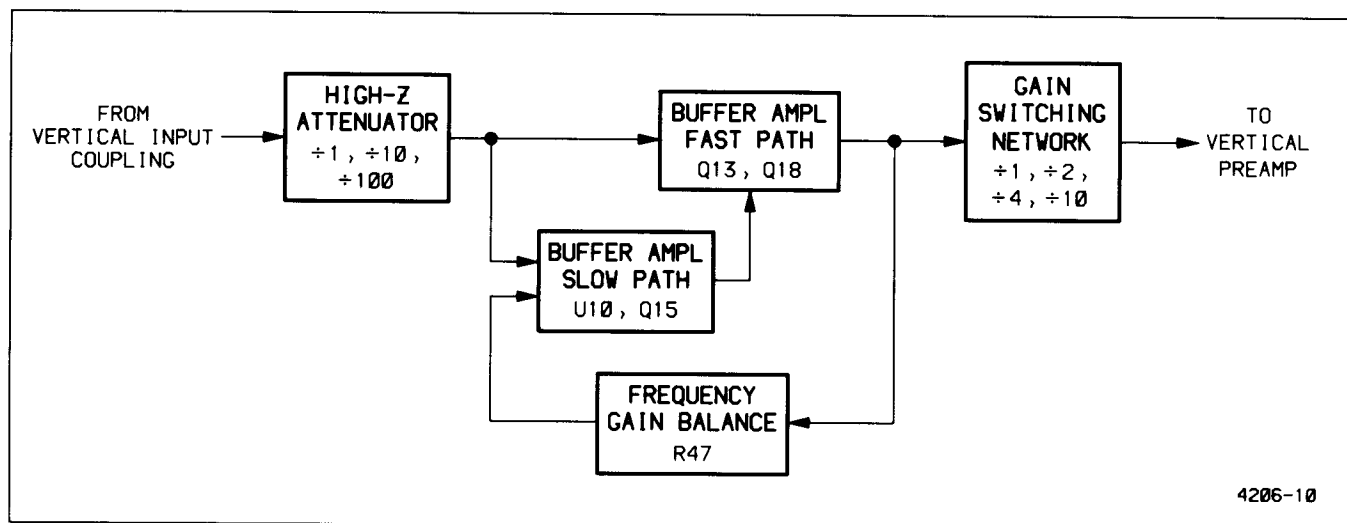

Figure 3-1. Block diagram of the Vertical Attenuators.

### Buffer Amplifier and Gain Switching Network

The Buffer Amplifier presents a high-impedance, low-capacitance load to the signal from the High-Impedance Attenuator and a low output impedance to the Gain Switching Network. A dual-path amplifier is used to combine high-dc stability with high-speed performance.

In the slow path, the input signal is applied to both the gate of source-follower Q13 and the inverting input of U10 through the divide-by-two network composed of R3 and R5. Transistor Q13 and emitter-follower Q18 isolate the input signal from the loading of the Gain Switching Network. The divider network at the output of the Amplifier (R46, R47, and R48) is connected to the other input of U10. Amplifier U10 compares the two divider voltages and changes the conduction level of current-source transistor Q15 to correct for any error at the source of Q13. Capacitor C10 limits the bandwidth of U10 so that the slow path responds only to frequencies below 100 kHz.

In the fast path, input signals are coupled through R6, C6, Q13, and Q18 to the circuit output. By adjusting R47, the gain in both paths is matched. Input offset voltage compensation for U10 is provided by R10 to eliminate trace shifts when switching between Volts/Div settings.

The Gain Switching Network divides down the Buffer Amplifier output signal for application to the Paraphase Amplifier and has an output impedance of 75  $\Omega$  for all Volts/Div switch settings. The particular Volts/Div switch setting will determine which contacts of S10 are closed and therefore whether the Paraphase Amplifier will receive a  $\div 1$ ,  $\div 2$ ,  $\div 4$ , or  $\div 10$  signal.

### Paraphase Amplifier

The Paraphase Amplifier converts the single-ended signal from the Gain Switching Network into a differential signal for application to the Vertical Preamp. Included in the circuitry is switching that provides extra gain for the 2 mV position of the VOLTS/DIV switch, adjustments for amplifier dc balance, and circuitry for the Variable Volts/Div function. Additionally, the Channel 2 Paraphase Amplifier contains circuitry to invert the Channel 2 display.

The signal from the Gain Switching Network is applied to the base of one transistor in U30. The other input transistor is biased by the divider network composed of R30, R31, and R33 to a level that will produce a null between the outputs of U30 (no trace shift on the crt screen) when the VOLTS/DIV control is switched between 5 mV and 2 mV. Emitter current for the two input transistors is supplied by R21, R22, R23, and R25, with R29 serving as the gain-setting resistor between the two emitters. In the 2 mV position, amplifier gain is increased by closing contact 15 of S10 to shunt R29 with R26.

The collector current through the two input transistors serves as emitter current for the two differential output transistor pairs. Base-bias voltages for the two pairs are derived from the divider network composed of R39, R41, R42, and R43. Monolithic IC U30 has matched transistor characteristics, so the ratio of currents in the two diodes connected to pin 11 determines the current ratios in the output transistor pairs. As VOLTS/DIV Variable potentiometer R43 is rotated from the calibrated to uncalibrated position, the conduction level of the transistors connected to R35 will increase. Since the transistor pair outputs are cross-wired, this increased conduction will subtract from the signal produced by the

transistors connected to R38 and the overall gain of the Amplifier will decrease. Potentiometer R25 adjusts the balance of the Amplifier so there is minimal dc trace shift as the VOLTS/DIV Variable control is rotated.

Incorporated in the Channel 2 Paraphase Amplifier is circuitry to invert the polarity of the Channel 2 signal. When INVERT switch S90 is out, the transistor pairs in U80 are biased as they are in U30 and there is no trace inversion. For the IN position of S90, connections to the bases of the output transistor pairs are reversed to produce an inverted Channel 2 trace. Potentiometer R75 is adjusted so that there is minimal dc trace shift as the INVERT button is changed between the IN and OUT positions.

## VERTICAL PREAMPLIFIERS

The Vertical Preamp, shown on Diagram 2, utilizes differential signal current from the Paraphase Amplifier to produce differential output current to drive the Delay Line Driver. Internal trigger signals for the Trigger circuitry are picked-off and channel selection for crt display is controlled by the Channel Switch circuitry.

Common-base transistors Q102 and Q103 convert differential current from the Paraphase Amplifier into level-shifted voltages that drive the bases of the input transistors of U130 and the Internal Trigger circuitry. Emitter current for the input transistors is supplied by Q114 and Q115, and the base bias is adjusted by R111. The collector current of each input transistor of U130 serves as emitter current for two differential output transistor pairs. One of the collectors of each output pair is grounded and the other provides output drive to the Delay Line Driver. The base voltages of the transistors with grounded collectors are held at ground potential by R136. The base voltages of the other transistors are controlled by the Channel Switch and Trigger View circuitry.

When Channel 1 is selected to drive the Delay Line Driver, the Q output of U540A is HI. The transistors with the ungrounded collectors will then be forward-biased and the Channel 1 signal will be conducted through to the Delay Line Driver. If Channel 1 is not selected, then the Q output of U540A is LO. The transistors with the ungrounded collectors are then reverse-biased and the output signals will be conducted to ground by the other transistor pair. The gain of the Preamp is set by adjusting R145 to determine how much signal current will be shunted between the two differential outputs.

When TRIG VIEW push button S200 is pressed in, -8.6 V is applied to R138 and R188 to turn off the transistors in U130 and U180 with ungrounded collectors. Both the

Channel 1 and Channel 2 output signals are then conducted to ground. Zener diode VR200 turns on and CR200 and CR201 become reverse biased. Trigger View transistors Q440 and Q441 are then coupled to the Delay Line Driver through forward-biased diodes CR202 and CR203. The crt trace will then be a display of the A Trigger signal.

## CHANNEL SWITCH AND VERTICAL OUTPUT

The Channel Switch circuitry, shown on Diagram 2, utilizes the front-panel VERTICAL MODE switches to select the crt display format. See Figure 3-2 for a block diagram of the circuit.

When any display mode other than X-Y is selected, the XY line connected to S550 is at ground potential. VERTICAL MODE switches S545 and S550 control the connection between the XY line and the  $\bar{S}$  and  $\bar{R}$  inputs of U540A to obtain the various display formats described below.

**CHANNEL 1 DISPLAY ONLY.** The CH 1 position of S550 grounds the  $\bar{S}$  input of U540A while the  $\bar{R}$  input is held HI by R539. This will produce a HI and a LO on the Q and  $\bar{Q}$  outputs respectively, and the Channel 1 Preamp signal will drive the Delay Line Driver as described in the "Vertical Preamp" section. The Channel 2 Preamp will be disabled.

**CHANNEL 2 DISPLAY ONLY.** The CH 2 position of S550 holds the  $\bar{R}$  input of U540A LO through CR538 and the  $\bar{S}$  input is held HI by R538. The outputs will then be Q LO and  $\bar{Q}$  HI to enable the Channel 2 Preamp signal to drive the Delay Line Driver while the Channel 1 Preamp is disabled.

To display the ADD, ALT, or CHOP formats, S550 must be in the BOTH position to ground the A, C, and F pins of S545.

**ADD DISPLAY.** In the ADD position of S545, both the  $\bar{S}$  and  $\bar{R}$  inputs of U540A are held LO by CR534 and CR537. The Q and  $\bar{Q}$  outputs are then both HI and signal currents from the Channel 1 and Channel 2 Preamps add together to drive the Delay Line Driver.

**CHOP DISPLAY.** In the CHOP position, the Chop Enable line is held LO keeping the Q output of U540B HI. This enables multivibrator U537D to run at a frequency that is determined by R544, R545, and C545. The output of U537C, the inverted output of the multivibrator, is used to drive U537A and U537B.

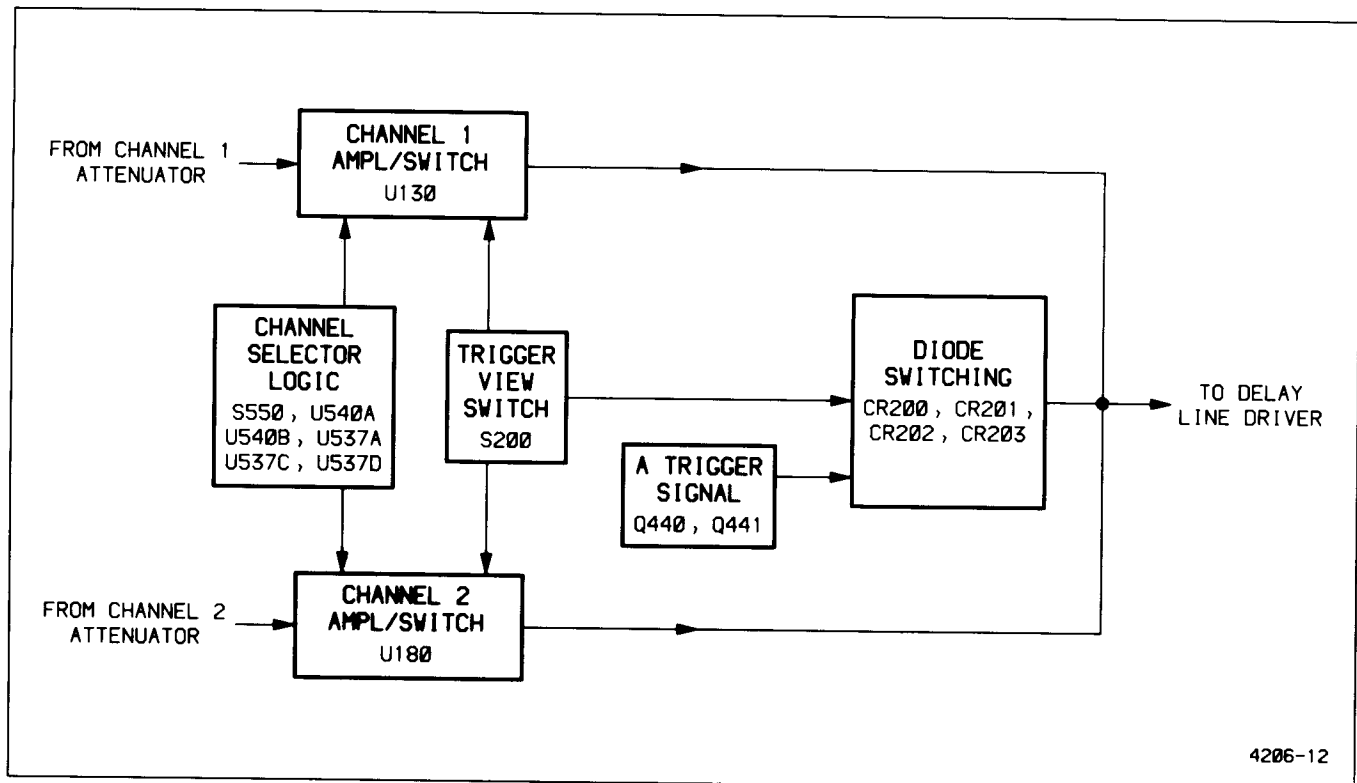

Figure 3-2. Block diagram of the Channel Switching circuitry.

Coupling capacitor C547 and resistors R547 and R548 form a differentiating circuit that produces positive- and negative-going short-duration pulses. These pulses are inverted by U537B to generate the Chop Blank signal utilized by the Z-Axis Amplifier.

The Alt Sync signal applied to one input of U537A is HI except during Holdoff. This allows the output of U537C to be inverted by U537A which drives the clock input of U540A. Since the  $\bar{Q}$  output of U540A is connected back to the D input and both the  $\bar{S}$  and  $\bar{R}$  inputs are HI, the outputs of U540A will toggle with each clock input. The Delay Line Driver will then be driven alternately by the Channel 1 and Channel 2 Preampifiers at a rate determined by multivibrator U537D.

**ALTERNATE DISPLAY.** In the ALT position, the  $\bar{\text{Chop Enable}}$  line is held HI and multivibrator U537D is disabled. The output of U537C will be LO and the Chop Blank signal from U537B will also be LO. Input signals to U537A will be the LO from U537C and the Alt Sync signal from the Holdoff circuitry in the A Sweep Generator. The output of U537A will then be the inverted Alt Sync signal which clocks U540A. This causes the outputs of U540A to toggle at the end of each sweep so that the Channel 1 and Channel 2 Preampifier signals will alternately drive the Delay Line Driver.

### Delay Line Driver

The Delay Line Driver converts the signal current from the Vertical Preampifiers or the Trigger View circuitry into a signal voltage for input to the Delay Line. Transistors Q202, Q203, Q206, and Q207 form a differential shunt-feedback amplifier with the gain controlled by R216 and R217. Amplifier compensation is provided by C210 and R210 and output common-mode dc stabilization by U225. Should the voltage at the junction of R222 and R223 deviate from zero, U225 will sink or source base current to Q202 and Q203 through R202 and R203. This will return the outputs of the Delay Line Driver to an average dc value of zero volts. Delay Line DL210 provides a vertical signal delay of about 90 ns so that the Sweep Generator has sufficient time to produce a sweep before the vertical signal that triggered the sweep reaches the crt deflection plates. This permits viewing the leading edge of the internal signal that originated the trigger pulse.

### Vertical Output Amplifier

The Vertical Output Amplifier provides final amplification of the input signals for application to the vertical deflection plates of the crt. Signals from the Delay Line are applied to a differential amplifier composed of Q230 and Q231 with low- and high-frequency compensation provided by the RC networks connected between the emitters. Thermal compensation is provided by RT236, and overall gain is set by R233.

The output stage of the Amplifier utilizes two totem-pole transistor pairs, Q254-Q256 and Q255-Q257, that convert the collector currents of Q230 and Q231 to proportional output voltages. Resistors R256, R258, R257, and R259 serve as feedback elements and also as divider networks so that each transistor in a pair drops half the final output voltage. The Amplifier output signals are applied to the vertical deflection plates of the crt to produce deflection of the crt beam.

BW LIMIT switch S226, C228 and C229, and a diode bridge consisting of CR226, CR227, CR228, and CR229, are utilized to reduce the bandwidth of the Amplifier if desired. With the bandwidth limit off, R226 is grounded and the nonconducting diode bridge isolates C228 and C229. With bandwidth limit on, R226 is connected to the +8.6 V supply and the diode bridge conducts. The two capacitors are no longer isolated and will attenuate high-frequency signals.

BEAM FIND switch S390 adjusts output-amplifier biasing to limit the voltage swing at the crt plates. This keeps the vertical trace within the graticule area for locating off-screen traces. With the switch in the normal out position, the -8.6 V supply provides emitter current to the Amplifier output stage through R261. When the BEAM FIND switch is in, the direct -8.6 V supply to R261 is removed and emitter current is now supplied through R261 and R262 in series. This reduces the amount of available emitter current and limits the Amplifier dynamic range.

### A/B Sweep Separation Circuit

The circuit composed of Q283, Q284, Q285, and associated components provides a means of vertically positioning the B trace with respect to the A trace during Alt Horizontal Mode displays. During the B Sweep interval, the  $\overline{\text{Sep}}$  signal from the Alternate Display Switching circuit is LO and Q283 is biased off. This allows A/B SWP SEP potentiometer R280 to affect the bias on one side of a differential current source composed of Q284 and Q285. This supplies a dc offset current to the Vertical Output Amplifier and changes the position of the B trace on the crt screen.

During the A Sweep interval, the  $\overline{\text{Sep}}$  signal is HI and Q283 is turned on. The base voltages of Q284 and Q285 are then the same, and equal current is supplied to both sides of the Vertical Output Amplifier so that no offset of the A trace occurs.

## TRIGGER AMPLIFIERS AND SWITCHING

The Trigger Amplifiers, shown on Diagram 3, provide signals to the A Trigger Generator circuit from either the Vertical Preamplifiers, the EXT INPUT connector, or the power

line. The A&B INT switch selects either Channel 1 or Channel 2 as the trigger source, and the A SOURCE switch selects between internal, line, or external trigger sources.

### Internal Trigger

Signals from the Vertical Preamplifiers drive the Internal Trigger Amplifier with channel selection determined by the VERTICAL and HORIZONTAL MODE switches.

Trigger pickoff from the Preamplifiers is accomplished by Q302 and Q303 for Channel 1, and Q327 and Q328 for Channel 2. The circuitry associated with Channel 2 is the same as that for Channel 1 except that it does not have a trigger offset adjustment.

Signals from the Channel 1 Preamplifier are applied to Q302 and Q303. These emitter-follower transistors each drive one input transistor in U310, and the collectors of the U310 input transistors in turn supply emitter current to two current-steering transistors. The compensation and biasing network connected to the emitters of the input transistors in U310 is fixed for Channel 2 but not for Channel 1. Potentiometer R309 adjusts the emitter bias levels of the two input transistors so that dc offsets between channels can be matched.

The base bias voltages of one transistor in each output differential amplifier pair is fixed by the divider network composed of R321 and R322. The other base voltage is controlled by the  $\overline{\text{Ch 1 Trig}}$  line from the Trigger Channel Switch. When the  $\overline{\text{Ch 1 Trig}}$  signal is HI, the transistors in each output pair with the collectors connected together are biased on and the other transistors are off. The collector signal currents are equal in magnitude but opposite in polarity and signal cancellation occurs. If the  $\overline{\text{Ch 1 Trig}}$  signal is LO, the other transistors in each pair will be biased on and an output signal will be developed across R314 and R315 to drive the Internal Trigger Amplifier.

Internal trigger channels are chosen by the A&B INT switch with the A SOURCE switch set to INT. The INT position of S392 reverse biases CR393 and CR399 to prevent external trigger signals or the line trigger signal from reaching the A Trigger Generator. Signals from the Internal Trigger Amplifier are passed to the A Trigger Generator through forward-biased CR372.

**CHANNEL 1.** For triggering from Channel 1, the A&B INT switch is set to CH 1. The XY line connected to S555 will be at ground potential and one input of U555B will be held LO by CR556. The output of U555B will then also be LO and the Channel 1 signal path through U310 will be enabled. The Channel 2 signal path is disabled by the outputs of both U555C and U565B being HI.

## Theory of Operation—2235 Service

**CHANNEL 2.** For triggering from Channel 2, the A&B INT switch is set to CH 2. One input each of U555C and U555D will be LO and force both gate outputs LO. The LO from U555C will enable the Channel 2 signal path through U335 and the HI outputs of U555B and U565C will disable the Channel 1 path.

**VERT MODE.** When the A&B INT switch is set to VERT MODE, trigger source selection is determined by the two VERTICAL MODE switches. For all VERTICAL MODE switch combinations except BOTH-CHOP, the  $\overline{V}$  Mode  $\overline{T}$  line is HI. The inputs and outputs of U555B, U555C, and U555D will all be HI, and triggering selection will then be determined by the inputs of U565B and U565C that are controlled by U540A in the Channel Switch circuit.

When Channel 1 is selected (VERTICAL MODE switch set to CH 1), the input to U565C will be HI. The gate output will be LO and the Channel 1 signal will be selected. The LO from the other output of U540A is applied to U565B and causes the  $\overline{Ch}$  2 Trig line to go HI and the Channel 2 Trigger signal is disabled.

When Channel 2 is selected (VERTICAL MODE switch set to CH 2), the outputs of U540A, U565B, and U565C will be the reverse of the states described for Channel 1 selection. The Channel 2 signal will be selected and the Channel 1 Trigger signal disabled.

When selecting ALT VERTICAL MODE, the inputs of U565B and U565C will toggle with each sweep. The outputs of the two gates will also toggle and the Trigger signal source will alternate with the displayed channel.

In the ADD VERTICAL MODE position, both inputs to U565B and U565C will be HI and the gate outputs will be LO. Both Channel 1 and Channel 2 signal paths will be enabled and their output current will be summed at the inputs of the Internal Trigger Amplifier to produce the internal trigger signal.

The CHOP VERTICAL MODE position grounds the  $\overline{V}$  Mode  $\overline{T}$  line and places a LO on an input of both U555B and U555C. The outputs of these two gates will then be LO and the signal to the Internal Trigger Amplifier will be the same as for the ADD mode.

### Internal Trigger Amplifier

The Internal Trigger Amplifier converts the differential trigger signals from the Vertical Preamplifiers into a single-ended signal that drives the X-Axis Amplifier and the A and B Trigger Generators.

Signal current is applied to the emitters of U350D and U350E. The collector current of U350D is converted to a voltage across feedback resistor R357. The opposite-phase collector current of U350E causes a voltage drop across R359 which adds to the voltage at the collector of U350C. This voltage appears at the base of U350A which buffers and level shifts the signal back to 0 V. The emitter signal of U350A drives the X-Axis Amplifier, the B Trigger Generator, and the base of U350B. The emitter signal of U350B in turn drives the A Trigger Generator whenever CR372 is forward biased.

### A External Trigger Amplifier

The A External Trigger Amplifier buffers signals applied to the EXT INPUT connector to drive the A Trigger Generator. Input signal coupling is determined by A EXT COUPLING switch S380 which selects AC, DC, or  $DC \div 10$  coupling.

When S380 is in the AC position, the input signal is ac-coupled through C376. In the DC position, the input signal is connected directly to the Amplifier. The  $DC \div 10$  position attenuates the input signal by a factor of 10 through the compensated divider composed of R377, R378, C380, and C381.

The signal is then applied to the gate of Q382A. This source-follower drives emitter-follower transistor Q384 which lowers the Amplifier output impedance. The two FETs are a matched pair, and since the gate and source of Q382B are connected together, Q382B will supply source current for Q382A such that there will be no voltage drop across the gate-source junction of Q382A. Protection-diode CR381 clamps the signal at the gate of Q382A to about  $-9$  V. The Amplifier output will drive the A Trigger Generator through forward-biased CR393 whenever the A SOURCE switch is set to EXT. When the A SOURCE switch is not set to EXT, the base-emitter junction of Q384 will be reverse biased and the Amplifier will be disabled.

### Line Trigger Amplifier

The Line Trigger Amplifier supplies a line-frequency trigger signal to the A Trigger Generator when the A SOURCE switch is in the LINE position.

Transformer T390 in the Power Supply provides a line-frequency signal through R397 to Q397. Diode CR399 is forward biased when S392 is in the LINE position, and the emitter signals of Q397 will drive the A Trigger Generator.

## A TRIGGER GENERATOR

The A Trigger Generator, shown on Diagram 3, supplies trigger signals to the A Sweep Generator. Included in the A Trigger Generator circuit are the P-P Auto Trigger, Auto Baseline, and TV Triggering circuitry.

### A Trigger Level Circuit

The A Trigger Level Circuit establishes voltages at the ends of the A TRIGGER LEVEL potentiometer as a function of the A TRIGGER push button selection and trigger signals selected by the A SOURCE switch.

In the P-P Auto and TV Field modes, Q413 is off and CR414 and CR415 are reverse biased. Trigger signals selected by the A SOURCE switch are applied to peak detectors consisting of Q420-Q422 and Q421-Q423. These peak detectors track dc levels and have a high voltage transfer efficiency. The positive- and negative-peak signal levels stored by C414 and C415 are near the peak levels of the trigger signal. Amplifiers U426A and U426B are configured as voltage followers with transistors Q428 and Q429 in the feedback loops. These transistors thermally compensate for Q420 and Q421 and level shift the amplifier outputs back to the original dc levels of the input trigger signals. The output of U426A will be the positive peak voltage of the input trigger signal and the output of U426B will be the negative peak voltage. Potentiometers R434 and R435 adjust for dc offsets in the trigger circuitry.

In the Norm mode, +8.6 V is applied to the junction of R411 and R414. Diode CR414 is forward biased, turning on Q413 which forward biases CR415. Input transistors Q420 and Q421 are then biased off and no trigger signals will reach the A Trigger Level circuit. The inputs and outputs of U426A and U426B will then be fixed voltages and independent of trigger-signal amplitude.

### A Trigger Level Comparator

The A Trigger Level Comparator compares signals selected by the A TRIGGER SOURCE switch to a voltage set by the A TRIGGER LEVEL control. Positive or negative slope triggering is selected by the A TRIGGER SLOPE switch.

Transistors U460B and U460E compare the wiper voltage on the A TRIGGER LEVEL control to the input trigger signal, and the transistor with the higher base voltage will conduct more of the available emitter current. The output collector currents supply emitter current to two transistor pairs which serve as cross-wired switches that are biased on or off by the A TRIGGER SLOPE switch. When S464 is set to the positive slope position, U460C and U460F are

biased on and U460A and U460D are biased off. For the negative slope position, the transistors reverse states to invert the comparator output polarity.

### A Schmitt Trigger and TV Trigger Circuit

This circuitry generates a signal that drives the A Trigger Logic as a function of the Trigger Level Comparator output signal and the A TRIGGER Mode switches.

The output signals from the A Trigger Level Comparator drive Q460 and Q463. These transistors are configured as a current mirror that converts the differential output to a single-ended current to drive amplifier U480C. Slope Balance potentiometer R471D corrects for dc offsets between positive and negative slope. Shunt-feedback amplifier U480C converts a current input to a voltage output to drive the input of the Schmitt Trigger, U480D, through R469. Positive feedback for the Schmitt Trigger is provided by potentiometer R479, and C479 reduces trigger jitter by increasing positive feedback at higher frequencies. The setting of R479 determines the circuit hysteresis.

When TV Field is not selected, the TV Trig Enable line connected to R402 and R473 is LO. Transistors Q402 and Q403 are biased off and a LO is placed on one input of U480A by R474. This LO input will cause U480A to invert the output from U480D. With Q403 off, a LO will be placed on one input of U480B by R405 and U480B will also act as an inverter. The A Trigger signal at the output of U480B is therefore the same as the input signal to U480A.

When TV Field is selected, the TV Trig Enable line is HI. The outputs of U480D will determine the conduction states of Q402 and Q403, and the input of U480A connected to R473 will be HI. The output of U480A will be LO and U480B will invert the signal at its other input. Signals at the collector of Q403 are filtered by C408, R405, and C405 to reject TV video information and average the TV horizontal-sync pulses. Setting the trigger-level threshold near the center of the horizontal-sync-pulse swing establishes the untriggered level. When the TV vertical-sync block occurs, the output of the filter applied to U480B pin 7 rises to a level that will cause the Schmitt Trigger circuit to switch. Precise TV field synchronization is obtained as a result of this filtering action. The A Trigger signal output will be the inverse of the filtered signal appearing at U480B pin 7.

## A SWEEP GENERATOR AND LOGIC

The A Sweep Generator and Logic circuitry, shown on Diagram 4, produces a linear voltage ramp that is amplified by the Horizontal Amplifier to provide horizontal deflection of the crt beam. The Sweep Generator circuits also produce

## Theory of Operation—2235 Service

signals that are used to generate correct timing of the crt unblanking and intensity levels used for viewing the display. See Figure 3-3 for the block diagram of the A Sweep Generator and Logic circuitry.

The Sweep Logic circuitry controls the holdoff time, starts the sweep upon reception of a trigger signal, and terminates the sweep at the proper sweep level. When using P-P Auto or TV Field triggering, the Sweep Logic circuitry will cause the Sweep Generator to free run, producing a baseline trace if a trigger signal is not received within a pre-determined time period.

### A Miller Sweep Generator

The A Miller Sweep Generator produces a linear voltage ramp that drives the Horizontal Amplifier. It produces this ramp by maintaining a constant current through timing capacitors to obtain a linearly increasing voltage.

Field-effect transistors Q704A and Q704B are matched devices with Q704B sourcing current for Q704A. Since the gate and source of Q704B are connected together, the source current of Q704A will be of a magnitude such that there is no voltage drop across its gate-source junction.

When the sweep is not running, Q701 is biased on to hold the timing capacitors in a discharged state. The low impedance of Q701 in the feedback path holds the A Miller Sweep output near ground potential. The voltage across Q701, in addition to the base-emitter voltage of Q706, prevents saturation of the output device.

A sweep ramp is initiated when Q576 is biased off. This will bias off Q701 and the timing capacitors can charge at a rate determined by timing resistors R701 and R702 and the position of A SEC/DIV switch S701. One end of timing resistor R701 is connected to the wiper of R721 and the other end is connected to the input of the Miller integrator. Due to feedback from the circuit output through the timing capacitors, the integrator input voltage remains fixed and establishes a constant voltage across the timing resistors. This constant voltage, which produces a constant current through the timing capacitors, results in a linearly increasing voltage at the output of the A Miller Sweep circuit.

When the output reaches approximately 12 V, the Sweep Logic circuitry will initiate the holdoff period in which Q701 is turned on and the A Sweep Generator is reset. This holdoff period is necessary so that the timing capacitors can be fully discharged before another sweep starts. Capacitors C702 and C703 are always in the charging circuit and are used for high sweep speeds. Capacitor C701A in series with C701B are used for medium sweep speeds, and C701B is used for slow sweep speeds.

The Sec/Div Variable circuitry utilizes an operational amplifier to maintain a constant reference voltage at one end of R721 independent of the circuit load. The voltage applied to the timing resistors varies with the rotational position of R721, the SEC/DIV Variable control. A fixed dc voltage is applied to the noninverting input of the operational amplifier and feedback resistors R717 and R718 establish double that voltage at the anode of VR720.

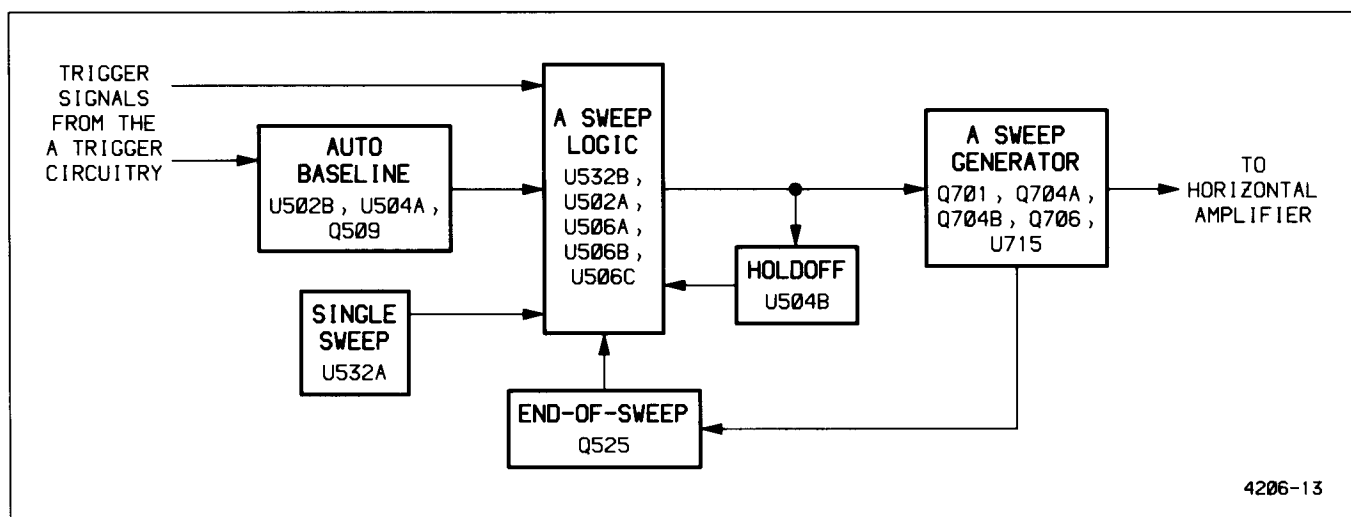

Figure 3-3. Block diagram of the A Sweep Generator and Logic circuitry.

## A Sweep Logic

The A Sweep Logic circuitry controls sweep generation, as a function of incoming trigger signals and the A Trigger mode selected.

Incoming trigger signals from the output of U480B will clock U502, a one-shot multivibrator, and cause the Q output to go from LO to HI. If another trigger signal is not received by U502 within a time period determined by the time constant of R503 and C501, the Q output will return LO. Whenever trigger signals are being received, the  $\bar{Q}$  output of U502 will bias on Q509 and illuminate TRIG'D LED DS518. The output state of U502 is used in the Auto Baseline circuit as described in the "P-P AUTO and TV FIELD" section.

**NORM.** When NORM Trigger mode is selected, input pin 12 of U532D is held HI by S401B, causing the gate output to also be HI. The output of U532C will then be LO and U506A will not be held reset. Input pin 4 of U532A is held HI by S401C, causing the output to be LO which places a LO on the D input of U506A. Trigger signals received at the clock input of U506A will then clock this LO to the Q output.

During the previous holdoff period, U506A had been set by U532B so that the  $\bar{Q}$  output went LO. This biased on Q576 and the A Miller Sweep was prevented from running. Whenever U506A is clocked following holdoff by a trigger signal, the LO on the D input will be transferred to the Q output and the  $\bar{Q}$  output will go HI. This will bias off Q576 and the A Miller Sweep will generate the sweep ramp as described in the "A Miller Sweep Generator" section. When the ramp voltage is about 12 V, Q525 will be biased on. The output of U532B will change from LO to HI, setting U506A and biasing on Q576. With Q576 conducting, holdoff one-shot U504B will be triggered and the A Miller Sweep Generator will be reset to turn off Q525.

With U504B triggered, the  $\bar{Q}$  output changes from HI to LO and will stay LO for a time duration determined by the Var Holdoff circuitry and the A SEC/DIV switch position. VAR HOLDOFF potentiometer R9521 determines the amount of charging current available to charge C518, C519 or C520 at pin 15 to the threshold voltage level on pin 14. During the time the  $\bar{Q}$  output is LO, the set input of U506A is held HI so that no trigger pulses can initiate a new sweep. When pin 15 of U504B reaches the threshold voltage on pin 14, the  $\bar{Q}$  output goes HI to end the holdoff period and release U506A from the set condition. The circuit is then enabled to generate another sweep once a trigger signal is again applied to the clock input of U506A.

**P-P AUTO and TV FIELD.** When P-P Auto or TV Field is selected, the Auto Baseline configuration is enabled. Pin 12

of U532D is held LO by R569 and the output will follow the signal provided by the Q output of U502. If trigger signals are being received by U502, the output of U532D will be HI and cause the output of U532C to be LO. Flip-flop U506A will respond to trigger signals as described in the "NORM" section. If trigger signals are not being received by U502, the output of U532D will be LO. The output of U532C will then be the inverse of the input signal applied to pin 11 so that U506A will be reset when holdoff ends, causing a sweep to be generated. With no new trigger pulses being applied to the circuitry, U506A will be continuously set and then reset in this manner to generate sweeps.

**SGL SWP.** In the Sgl Swp mode, both the P-P AUTO and NORM buttons are out. This results in a LO at the output of U532C so that U506A is not held reset. A LO is also on input pin 4 of U532A.

During the previous holdoff period, U532B had reset U506B to cause the Q output to be LO. The D input of U506A will therefore be HI and clock signals to the gate will keep the  $\bar{Q}$  output LO and the sweep disabled. When the SGL SWP button is pushed in, the  $\bar{Q}$  output of U504A will go LO for a time period determined by the time constant of R504 and C504 and then return HI. This HI will then clock through the HI on the D input of U506B to the Q output. Consequently the output of U532A will go LO and CR514 will be reverse biased to bias on Q511 and light the READY LED. The next trigger pulse applied to the clock input of U506A will then initiate a sweep as described previously. At the end of the sweep, U506B will again be reset, causing the TRIG'D LED to go out and place a HI on the D input of U506A. A new sweep will not be initiated until the SGL SWP button is again pushed.

**X-Y.** In the X-Y mode of operation, the  $\bar{X}\bar{Y}$  line is LO which holds the input of U532B LO through CR518. The output of U532B will hold U506A set and no sweeps can be initiated.

## ALTERNATE B SWEEP

The Alternate B Sweep circuitry, shown on Diagram 5, produces a linear voltage ramp that is amplified by the Horizontal Amplifier to provide the B Sweep horizontal deflection on the crt. The Alternate B Sweep circuitry also produces the sweep-switching signals that control the display of the A and B Sweeps, and the gate signals used by the Intensity and Z-Axis circuits to establish the crt unblanking and intensity levels needed for producing both the A Intensified and B Sweep displays.

The B Sweep ramp is enabled by the B Sweep Logic circuit either immediately after the end of the established

## Theory of Operation—2235 Service

delay time (Runs After Delay) or upon receipt of the first trigger signal after the delay time has elapsed. This delay time is a function of the B Delay Time Position Comparator circuit and the A sweep.

### B Miller Sweep Generator

The B Miller Sweep Generator is composed of Q709, Q710A, Q710B, Q712, and associated timing components. This circuit produces the B Sweep and functions in the same manner as the A Miller Sweep Generator; see the "A Miller Sweep Generator" section for a description of circuitry operation. The output at the collector of Q712 drives the Horizontal Amplifier and Q643.

### B Trigger Level Comparator

The B Trigger Level Comparator is composed of transistor array U605, U625C, Q619, and Q620. This circuit determines both the trigger level and slope at which the B triggering signal is produced. It functions in the same manner as the A Trigger Level Comparator with the exclusion of the TV Trigger and Trigger View circuitry. See the "A Trigger Level Comparator" section for a description of the circuit operation. Buffering of the inverting and noninverting outputs of U625D is provided by U625A and U625B, and Q630 and Q631 level shift the signals to TTL levels. The circuit output at the collector of Q630 supplies trigger signals to clock U670A.

### Runs After Delay

The Runs After Delay circuit allows the B Sweep Logic to generate a B Sweep independently of any B Trigger signals. In the Runs After Delay mode, B TRIGGER LEVEL control R602 is rotated fully clockwise. This biases off Q637 and places a LO on the collector. Inverter U660D will then have a HI output with resistor R640 providing positive feedback. The output of U660A will therefore be LO and U670A will be held set with the  $\bar{Q}$  output LO.

If the B TRIGGER LEVEL control is not fully clockwise, Q637 is biased on and the B Sweep is in the triggered mode. The output of U660D will be LO, the output of U660A will be HI, and U670A will no longer be held set.

Operation of the B Sweep Logic circuitry under both of these conditions is described in the "B Sweep Logic" discussion.

### B Delay Time Position Comparator

The B Delay Time Position Comparator circuit compares the amplitude of the A Sweep sawtooth output voltage to the dc voltage level set by B DELAY TIME POSITION po-

tentiometer R6440. The output of the comparator is used to initiate a B Sweep and to control the B Z-Axis Logic circuit switching.

The inputs to the comparator, U655, are the wiper voltage of R9644 and the A Sweep voltage from the divider network composed of R651, R652, and R653. Input voltage ranges to the comparator are determined by VR645 and R646 for the noninverting input and by R652 for the inverting input. Delay Start potentiometer R646 is adjusted in conjunction with potentiometer R652 to set the B DELAY TIME POSITION dial calibration.

The output of the comparator is enabled or disabled by the strobe signal connected to pin 6. When the  $\bar{A}$  Only signal is HI, the comparator is enabled. When  $\bar{A}$  Only is LO, the output of the comparator is a high impedance and therefore a HI is present on pin 9 of U680C.

### B Sweep Logic

The B Sweep Logic circuitry utilizes signals from the associated B Sweep circuitry to generate control signals for both the B Miller Sweep and the B Z-Axis Switching Logic circuits.

In the Runs After Delay mode, U660A places a LO on the  $\bar{S}$  input of U670A. During the previous holdoff period, U680D pin 13 strobed LO. The output of the flip-flop composed of U680C and U680D went HI and the output of U660F went LO. With both the  $\bar{S}$  and  $\bar{R}$  inputs of U670A LO, the  $\bar{Q}$  output is HI to bias on Q709 and prevent the B Miller Sweep from running. Once the A Sweep voltage at U655 pin 3 exceeds the voltage at pin 2, the comparator output will go LO. The flip-flop composed of U680C and U680D will change output states and cause the  $\bar{R}$  input of U670A to be HI. The LO on the  $\bar{S}$  input will then cause the  $\bar{Q}$  output of U670A to go LO. This will shut off Q709 and the B Miller Sweep Generator will produce a linear ramp. If the ramp voltage reaches about 12 V, sweep-end comparator Q643 will turn on and cause the output of U665D to go HI. The B Miller Sweep Generator will continue to run, but the trace will be blanked because the  $\bar{B}$  Gate line is HI which reverse biases CR817. Once the ramp is at approximately 13 V, VR712 will conduct and prevent the voltage from increasing further.

The B Sweep Generator will be reset for another sweep by one of two means. If the A Sweep doesn't end before the B Sweep, the Generator will not be reset until the Alt Sync line goes from HI to LO to change the U680C-U680D flip-flop output states. The  $\bar{R}$  input of U670A will then be LO, causing the  $\bar{Q}$  output to be HI and reset the Generator. Depending on the settings of the A and B SEC/DIV switches, the A Sweep may end before the B Sweep. If this occurs, the Alt

Sync line will go LO at the end of the A Sweep and cause an immediate resetting of the Generator. In either case, a new sweep will be initiated the next time the A Sweep voltage at U655 pin 3 exceeds the voltage at pin 2.

When not in the Runs After Delay mode, the output of U660A is HI and U670A has a HI on both the  $\bar{S}$  and D inputs. The circuitry connected to the R input of U670A functions as described above. When the output of U660F goes HI, U670A is no longer held reset and the first B trigger signal from the collector of Q630 will clock through the HI on the D input. The  $\bar{Q}$  output of U670A will then go LO and a B Sweep will be initiated.

### Alternate Display Switching Logic

The Alternate Display Switching Logic circuitry controls both the Horizontal Amplifier sweep switching and the B Z-Axis Logic switching.

HORIZONTAL MODE switch S648 selects the input logic levels that are applied to the circuitry. In the A Horizontal Mode, the  $\bar{S}$  input of U670B is LO and the R input is HI. This holds U670B set and allows only the A Sweep to be passed to the Horizontal Amplifier. In the B Horizontal mode, the set input of U670B is HI and the reset input is LO to hold U670B reset and allow only the B Sweep to reach the Horizontal Amplifier.

With S648 set to ALT, and for all settings of the VERTICAL MODE switches except BOTH-ALT, the  $\bar{V}_{alt}$  signal applied to U660E and the  $\bar{S}$  and  $\bar{R}$  inputs of U670B are all HI. The LO output of U660E causes the output of U680B to be HI, and whenever the Alt Sync signal applied to pin 1 goes LO, the gate output will change from LO to HI and clock U670B. The outputs of U670B will therefore toggle with each Alt Sync signal transition to alternately enable the A and B Sweeps to reach the Horizontal Amplifier. Whenever the B Sweep is selected for the Horizontal Amplifier, the  $\bar{Q}$  output of U670B will be HI. This HI is applied to U665C pin 9, and since pin 10 is also HI, the Sep signal from U665C will be LO to enable the A/B Sweep Separation circuitry.

When the CH 1-BOTH-CH 2 VERTICAL MODE switch is set to BOTH, the ADD-ALT-CHOP switch becomes functional. In the ALT VERTICAL MODE position, the  $\bar{V}_{alt}$  signal is LO, the Halt signal is HI, and the CH 1 Selected signal is a TTL square wave that switches states at the end of the A Sweep. Input pin 4 of U680B will be HI and the gate output will be the inverse of the CH 1 Selected signal. This output signal is NANDed with the Alt Sync signal by U680A to clock U670B. Whenever the Alt Sync signal goes LO at the end of a sweep and the Ch 1 Selected signal switches from LO to HI, U670B will be clocked. Since only positive transitions on the clock input will cause the flip-flop to change

output states, two A Sweeps are required to cause the flip-flop output levels to switch. With this switching arrangement, the crt will first display the two A Intensified Sweeps and then the two Alternate B Sweeps.

### B Z-Axis Logic

The B Z-Axis Logic circuitry switches signal current levels to drive the Z-Axis Amplifier for both the B and the A Intensified Sweep displays. The current supplied is summed with the other signal inputs on the Z-Drive line.

When the HORIZONTAL MODE switch is in the ALT position, pin 5 of U665B is HI. The outputs of U670B and the  $\bar{B}$  Gate signal from the output of U665D together with the IN TENSITY controls determine the intensity of the A and B Sweeps.

When the A Sweep is displayed, the Q output of U670B is HI and the  $\bar{Q}$  output is LO. These output levels will bias on Q680 and bias off Q685. The emitter voltage of Q680 will reverse bias CR817 to prevent Z-Axis drive current from flowing through the diode. With Q685 off, additional Z-Axis drive current to intensify the A Sweep will be supplied whenever CR685 is biased off. Since input pin 5 of U665B is HI, the gate output and therefore the conduction state of CR685 is determined by U665B pin 4. Whenever the B Sweep is running, the output of U665D will be LO. This will cause the output of U665B to also be LO and CR685 will be biased off. If the B Sweep is not running, the output of U665B will be HI and CR685 will be biased on. This will bias off CR816 and the A Sweep will not be intensified.

If the outputs of U670B are set to display the B Sweep (Q LO and  $\bar{Q}$  HI), Q680 will be biased off and Q685 will be biased on. The emitter voltage of Q685 will reverse bias CR816 to prevent Z-Axis drive current from flowing through the diode. With Q680 off, the B Sweep will be displayed if CR680 is reverse biased. Whenever the B Sweep is running, the output of U665D is LO. Diode CR680 will then be reverse biased and Z-Axis drive current will flow through CR817. If the B Sweep is not running, the output of U665D is HI, forward biasing CR680 and therefore reverse biasing CR817. No Z-Axis drive current can then flow through CR817.

## HORIZONTAL

The Horizontal Amplifier circuit, shown on Diagram 6, provides the output signals that drive the horizontal crt deflection plates. Signals applied to the Horizontal Preamplicator can come from either the A or the B Miller Sweep Generator (for sweep deflection) or from the XY Amplifier (when X-Y display mode is selected). Sweep switching is under control

## Theory of Operation—2235 Service

of the Alternate Display Switching Logic circuit. See Figure 3-4 for the block diagram of the Horizontal Amplifier.

The Horizontal POSITION control, X10 Magnifier circuitry, and the horizontal portion of the Beam Find circuitry are also contained in the Horizontal Amplifier circuit.

### Horizontal Preamplifier

The Horizontal Preamplifier selects display modes and amplifies input signals for application to the Horizontal Output Amplifier.

The A and B Sweeps, selected by U670B in the Alternate Sweep circuitry, are applied to the emitters of Q742 and Q732 respectively through gain potentiometers R740 and R730. The transistors are biased into the active or cutoff regions by the control voltage applied at the cathodes of CR732 and CR742. Switching between the A and B Sweeps occurs within U760, with a negative input at pin 10 or 9 disconnecting the respective sweep from the rest of the amplifier. The Horizontal POSITION control adjusts the crt trace position through pin 14. Output bias current levels are set by R751 at pin 5 and frequency compensation for X-Axis signals is provided by C751 connected to pin 13.

Horizontal X10 Gain is set by the resistor network connected between pins 3 and 6. When the X10 Magnifier is on, S721 is closed and the timing adjustment is made using R754. Magnifier registration is adjusted by R749 so that there is no horizontal trace shift when switching between the X10 Magnifier on and off positions.

### X-Y Amplifier

The X-Y Amplifier amplifies the Channel 1 signal from the Internal Trigger circuitry for application to the Horizontal Preamplifier.

When the X-Y mode is selected, Q737 is biased on to establish a HI on U760 pin 12 so that the A and B Sweeps are disconnected from the Preamplifier outputs. The XY signal line will be LO and Q756 will be biased off to enable the X-Axis signal to drive the noninverting input of U758. The output of U758 will then be a function of the X-Axis signal and the Horizontal POSITION control wiper voltage. The X-Axis signal gain is adjusted by R760 and the input voltage from the Horizontal POSITION control at pin 14 is disconnected within U760 so that it does not affect the Preamplifier output. The input signal at pin 11 from U758 will be converted to a differential output signal and applied to the Horizontal Output Amplifier.

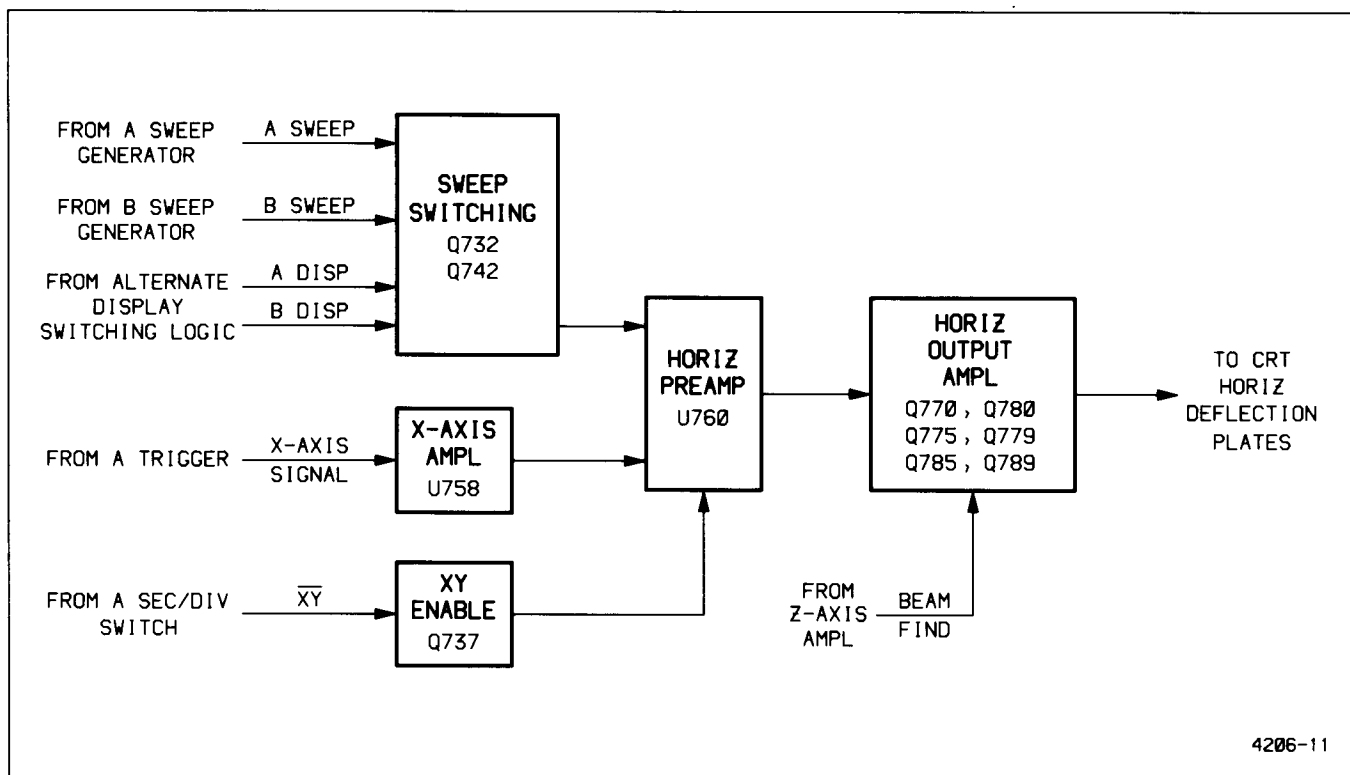

Figure 3-4. Block diagram of the Horizontal Amplifier.

When the X-Y mode is not selected, Q756 is biased on and the X-Axis signal is shunted to ground.

### Horizontal Output Amplifier

The Horizontal Output Amplifier provides final amplification of the horizontal signal to drive the horizontal crt deflection plates.

Signals from the (+) and (–) sweep outputs of U760 are used to drive two shunt-feedback amplifiers. Due to the feedback, the input impedance of these amplifiers is low. The base voltages of Q770 and Q780 are at nearly the same dc level due to forward-biased diodes CR765 and CR768 between the two emitters.

Transistors Q770, Q775, and Q779 form a cascode-feedback amplifier for driving the right crt horizontal deflection plate with R775 setting amplifier gain and C775 providing high-frequency compensation. For low-speed signals, Q779 serves as a current source for Q775, and at high sweep rates, the ramp is coupled through C779 to the emitter of Q779. This provides additional pull-up output current to drive the crt at high sweep rates. The amplifier consisting of Q780, Q785, and Q789 drives the left crt horizontal deflection plate in the same manner as described above with zener diode VR782 level shifting the collector signal of Q780.

The BEAM FIND function is implemented when S390 is pushed in to disconnect the cathode of CR764 from the –8.6 V supply. The voltage on the cathode of VR764 goes positive, causing CR780 and CR770 to be forward biased. Current from R764 causes the output common-mode voltage of the two shunt-feedback amplifiers to be shifted negative to reduce the available voltage swing at the crt plates. This prevents the trace from being deflected off-screen horizontally.

## Z-AXIS AMPLIFIER

The Z-Axis Amplifier, shown on Diagram 7, controls the crt intensity level via several input-signal sources. The effect of these input signals is either to increase or decrease trace intensity or to completely blank portions of the display. The Z-Drive signal current as determined by the A and B Z-Axis Switching Logic and the input current from the EXT Z AXIS INPUT connector (if in use) are summed at the emitter of common-base amplifier Q825 and thereby determine the collector current of the stage. This transistor provides a low-impedance termination for the input signals and isolates the signal sources from following stages of the Z-Axis Amplifier.

Common-base transistor Q829 establishes a constant current through R832. This current is divided between Q825

and Q829 with the portion through Q829 driving the shunt-feedback output amplifier consisting of Q835, Q840, and Q845. The bias level of Q825 therefore determines the amount of emitter current available to Q829. Feedback-resistor R841 establishes the transresistance gain which converts the input current to output voltage. Emitter-follower Q835 is dc coupled to Q840, and for low-speed signals Q845 acts as a current source. Fast transitions couple through C845, providing additional current gain through Q845 for fast voltage swings at the output of the Amplifier.

External Z-Axis input voltages establish proportional input currents through R822 and R823, and Amplifier sensitivity is determined by the transresistance gain of the shunt-feedback amplifier. Diode CR823 protects the Z-Axis Amplifier if excessive signal levels are applied to the EXT Z AXIS INPUT connector.

The intensity of the crt display in the A, B, and Alt Horizontal modes is determined by the INTENSITY controls and associated circuitry. The A INTENSITY potentiometer controls the base voltage of Q804 to determine the amount of emitter current that will flow through the transistor and therefore the level of the Z-Axis signal. Likewise the B INTENSITY potentiometer will control the base voltage of Q814 and the intensity of the B and Alt Sweep displays.

When only the A Sweep is displayed, Q586 and CR583 are biased off. The current through R818, as set by the A INTENSITY potentiometer, will flow through CR818 and Q825 to fix the voltage level at the Z-Axis Amplifier output. For a B-only display, Q586 is biased on to reverse bias CR818 and prevent A-intensity current from reaching Q825. Current determined by the base voltage of Q814 will flow through CR817 to Q825 and determine the B Sweep intensity. For an alternating A and B display, Q586 will be biased off when the A Sweep is displayed. During the portion of the A Sweep in which the B Sweep runs, current from R816 is allowed to flow through CR816 by the B Z-Axis Logic circuit to provide an intensified zone.

When CHOP VERTICAL MODE is selected, the Chop Blank signal is applied to the collector of Q825 through CR824 during the display-switching time. Signal current is shunted away from CR825, and the forward bias of Q829 increases to the blanking level. When blanked, the output of the Z-Axis Amplifier drops to a level that reduces the crt beam current below viewing intensity during the chop-switching transition.

For an X-Y display, CR818, CR817, and CR816 are reverse biased. The  $\overline{XY}$  signal is LO to reverse bias CR551 and allow current in R820 to flow through CR820. The crt intensity is then controlled by the A INTENSITY potentiometer which sets the current in R820 through Q804.

BEAM FIND switch S390 controls the base bias voltages of Q825 and Q829. When the BEAM FIND button is out,  $-8.6$  V is supplied to a base-biasing network. When the button is pushed in, the  $-8.6$  V supply is removed and the voltage at the anode of VR828 rises to about  $-5.6$  V. This turns off Q829 so that the amplifier output voltage is determined by R835 and the voltage at the BEAM FIND switch, as set by other parts of the Beam Find circuitry. The output voltage of Q835 will then be at a fixed level so that the INTENSITY controls and the Z-Drive signal have no control over the crt intensity. A bright trace or dot will then be displayed.

**Dc Restorer**

The Dc Restorer circuit produces the crt control-grid bias and couples both dc and ac components of the Z-Axis Amplifier output to the crt control grid. Direct coupling of the Z-Axis Amplifier output to the crt control grid is not employed due to the high potential differences involved. Refer to Figure 3-5 during the following discussion.

Ac drive to the Dc Restorer circuit is obtained from pin 16 of T948. The drive voltage has a peak amplitude of about  $\pm 100$  V, a frequency of about 20 kHz, and is coupled into the Dc Restorer circuit through C853 and R853. The cathode of CR851 is biased by the voltage applied from the wiper of Grid Bias potentiometer R851, and the ac-drive

voltage will be clamped whenever the positive peaks reach a level that forward biases CR851.

The Z-Axis Amplifier output voltage, which varies between  $+10$  V and  $+75$  V, is applied to the Dc Restorer at the anode of CR853. The ac-drive voltage will hold CR853 reverse biased until the voltage falls below the Z-Axis Amplifier output voltage level. At that point, CR853 becomes forward biased and clamps the junction of CR851, CR853, and R854 to the Z-Axis output level. Thus, the ac-drive voltage is clamped at two levels to produce a square-wave signal with a positive dc-offset level.

The Dc Restorer is referenced to the  $-2$  kV crt cathode voltage through R858 and CR854. Initially, both C855 and C854 will charge up to a level determined by the difference between the Z-Axis output voltage and the crt cathode voltage. Capacitor C855 charges from the Z-Axis output through R858, CR854, and CR855, to the crt cathode. Capacitor C854 charges through R858, CR854, R854, and CR853 to the crt cathode.

During the positive transitions of the ac drive, from the lower clamped level toward the higher clamped level, the charge on C854 increases due to the rising voltage. The voltage increase across C854 is equal to the amplitude of the positive transition. The negative transition is coupled

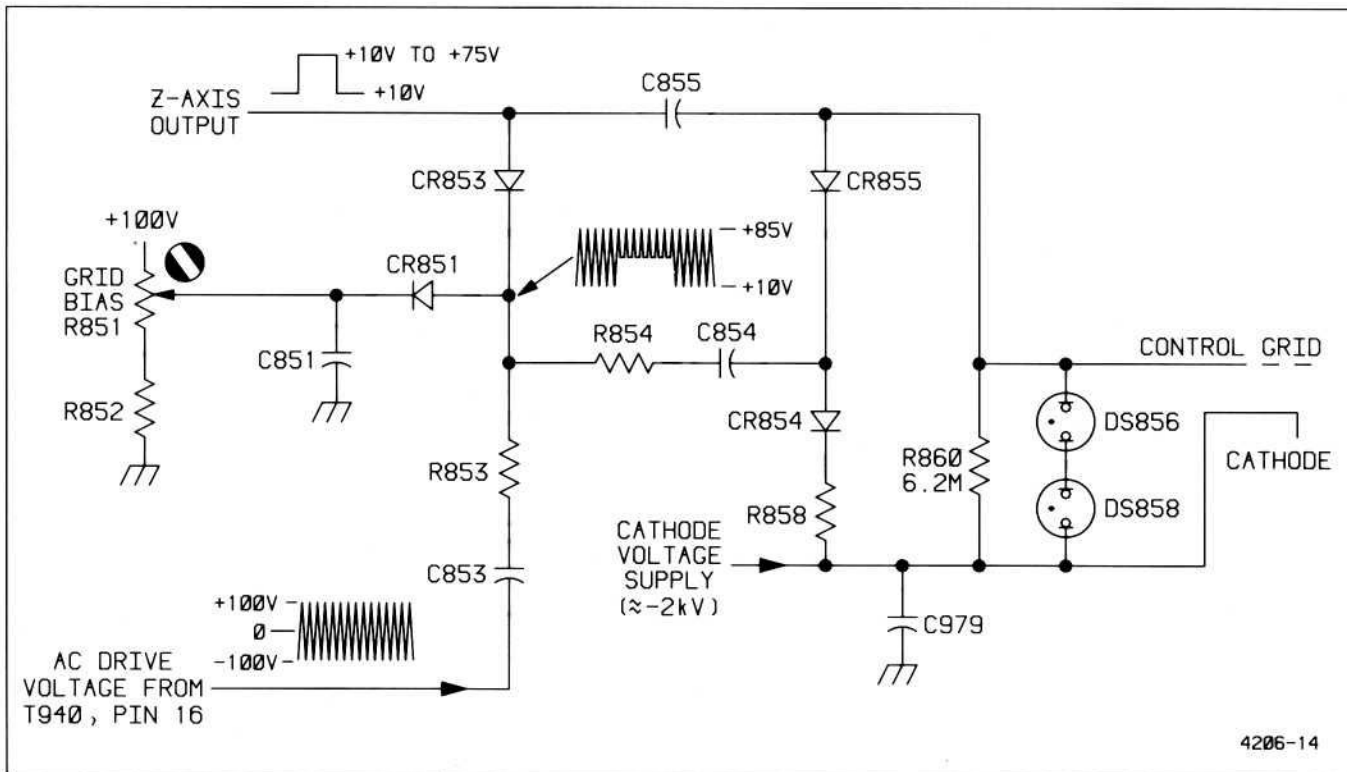

Figure 3-5. Simplified diagram of the Dc Restorer circuit.

through C854 to reverse bias CR854 and to forward bias CR855. The increased charge of C854 is then transferred to C855 as C854 discharges toward the Z-Axis output level. Successive cycles of the ac input to the Dc Restorer will charge C855 to a voltage equal to the initial level plus the amplitude of the clamped square-wave input.

The added charge on C855 determines the control-grid bias voltage. If more charge is added to that already present on C855, the control grid becomes more negative and less crt writing-beam current will flow. Conversely, if less charge is added, the control-grid voltage level will be closer to the cathode-voltage level and more crt writing-beam current flows.

During periods that C854 is charging, the crt control-grid voltage is held constant by the long time-constant discharge path of C855 through R860.

Fast-rise and fast-fall transitions of the Z-Axis output signal are coupled to the crt control grid through C855 to start the crt writing-beam current toward the new intensity level. The Dc Restorer output level then follows the Z-Axis output-voltage level to set the new bias voltage for the crt control grid.

Neon lamps DS858 and DS856 protect the crt from excessive grid-to-cathode voltage if the potential on either the control grid or the cathode is lost for any reason.

## POWER SUPPLY AND PROBE ADJUST

The Power Supply circuitry converts the ac power-line voltage into the voltages needed for instrument operation. It consists of the Power Input, Preregulator, and Inverter circuits (which drive the primary of the power transformer) and secondary circuits (which produce the necessary supply voltages for the instrument).

### Power Input

The Power Input circuit converts the ac power-line voltage to filtered dc for use by the Preregulator.

POWER switch S901 connects the ac power line through fuse F9001 to the bridge rectifier composed of CR901, CR902, CR903, and CR904. The bridge full-wave rectifies the source voltage, and the output is filtered by C906. Input surge current at the time of instrument power-up is limited by thermistor RT901. The thermistor resistance is moderately high when the power is first turned on, but decreases as the input current warms the device. The instrument is

protected from large voltage transients by suppressor VR901. Conducted interference originating within the power supply is attenuated by common-mode transformer T901, differential-mode transformer T903, line filter FL9001, and capacitors C900, C901, and C902.

### Preregulator

The Preregulator provides a regulated dc output voltage for use by the Inverter circuitry.

When the instrument is turned on, the voltage developed across C906 will charge C925 through R926. When the voltage has risen to a level high enough that U930 can reliably drive Q9070, U930 will receive operating supply voltage through Q930. This level is set by zener diode VR925 in the emitter of Q928 and by the voltage divider consisting of R925 and R927. The zener diode will keep Q928 off until the base voltage reaches approximately 6.9 V. Then Q928 will be biased into conduction and the resulting collector current will cause a voltage drop across R929. This voltage drop will bias on Q930, and the positive feedback through R930 will reinforce the turn-on of Q928. Thus Q930 and Q928 will drive each other into saturation very quickly. Once Q930 is on, U930 will begin to function.

Pulse-width modulator U930 controls the output voltage of the Preregulator by regulating the duty cycle of the pulse applied to the gate of Q9070. It utilizes an oscillator with the frequency determined by R919 and C919 (approximately 60 kHz) and with a sawtooth output voltage at pin 5. This sawtooth voltage is compared internally with the output voltage produced by the two error amplifiers. Whenever the sawtooth voltage is greater than the error amplifier output voltage, Q9070 is biased on to supply current to both C940 and the rest of the circuitry. The two error amplifiers maintain a constant output voltage and monitor the output current of the Preregulator. One input of each amplifier is connected through a divider network to the IC internal +5-V reference. The output voltage of the Preregulator is monitored by the voltage divider at pin 2. The voltage drop across R907, produced by the Preregulator output current, is applied to the current limit amplifier at pin 16.

When the instrument is first turned on, the current limit amplifier controls the conduction time of Q9070. While Q9070 is conducting, the output current increases until a sufficiently large voltage drop is developed across R907 to invoke the current-limit mode. The current limit amplifier holds the output current below the current-limit threshold of approximately 1 A. When the voltage across C940 reaches approximately 43 V, the voltage amplifier starts controlling the duty cycle of Q9070 and the Preregulator will not limit current unless there is excessive current demand.

## Theory of Operation—2235 Service

With Q9070 off, C907 charges to the output voltage of the Power Input circuit. When Q9070 turns on, current through the FET will come from the winding connected to pins 1 and 2 of T906 and from C907. Current to C907 is supplied by the winding connected to pins 4 and 5 of T906. When U930 shuts off Q9070, the collapsing magnetic field will raise the voltage at the anode of CR907. This diode then becomes forward biased and passes the currents supplied by C907 and the winding connected to pins 4 and 5 of T906. For this part of the cycle, current to C907 will be supplied by the winding connected to pins 1 and 2 of T906. This process will continue for each period of the oscillator, and the duty cycle controlling the conduction period of Q9070 will be altered as necessary to maintain 43 V across C940. To shut off Q9070 during each oscillator period, Q908 is used to discharge the gate-drain capacitance. Pin 10 of U930 goes LO, reverse biasing CR908 and turning on Q908 to shut off the FET.

Once the supply is running, power to U930 will be supplied from the winding connected to pins 6 and 7 of T906. Diode CR920 half-wave rectifies the voltage across pins 6 and 7 to keep filter capacitor C925 charged and to maintain supply voltage to U930 through Q930.

Instrument protection from excessive output voltage is supplied by silicon-controlled rectifier Q935. Should the Preregulator output voltage exceed 51 V, zener diode VR935 will conduct, causing Q935 to also conduct. The Preregulator output current will then be shunted through Q935, and the output voltage will very quickly go to zero. With the supply voltage of U930 no longer being provided by the winding connected to pins 6 and 7 of T906, the Preregulator will shut down and Q935 will be reset. The supply will then attempt to power up, but may again shut down if the overvoltage condition is again reached. This sequence continues until the overvoltage condition is corrected.

### Inverter

The Inverter circuit changes the dc voltage from the Preregulator to ac for use by the supplies that are connected to the secondaries of T948.

The output of the Preregulator circuit is applied to the center tap of T948. Power-switching transistors Q946 and Q947 alternate conducting current from the Preregulator output through the primary windings of T948. The transistor switching action is controlled by T944, a saturating base-drive transformer.

When the instrument is first turned on, one of the switching transistors will start to conduct and its collector voltage will drop toward the common voltage level. This will induce a

positive voltage from the lead of T944 which is connected to the base of the conducting transistor and reinforce conduction. Eventually T944 will saturate, and as the voltage across T944 (and T948) begins to reverse, the conducting transistor will cut off because of the drop in base drive. The other transistor will not start conduction until the voltage on the leads of T944 reverse enough to bias it on. This process will continue, and the saturation time of T944 plus the transistor-switching time will determine the frequency of Inverter operation (typically 20 kHz). After the initial Inverter start up, the switching transistors do not saturate; they remain in the active region during switching.

Diodes CR946 and CR947 serve as a negative-peak detector to generate a voltage for controlling the output of the error amplifier. Capacitor C943 charges to a voltage equal to the negative peak voltage at the collectors of Q946 and Q947, referenced to the Preregulator input voltage. This voltage level is applied to the divider composed of R937, R938, and R939. The error amplifier, composed of Q938 and Q939, is a differential amplifier that compares the reference voltage of VR943 with the voltage on the wiper of potentiometer R938. The current through Q939 will set the base drive of Q944 and thereby control the voltage on C944. This voltage will bias Q946 and Q947 to a level that will maintain the peak-to-peak input voltage of T948. The amplitude of the voltage across the transformer primary winding, and thus that of the secondary voltages of T948, is set by adjusting  $-8.6$  V Adj potentiometer R938.

At turn on, Q938 is biased off and Q939 is biased on. All the current of the error amplifier will then go through Q939 to bias on Q944. Diode CR945 allows the base of Q944 to go positive enough to initially turn on Q946 or Q947. The current through Q944 controls the base drive for Q946 and Q947. Base current provided by base-drive transformer T944 will charge C944 negative with respect to the Inverter circuit floating ground (common) level.

### Crt Supply

High-voltage multiplier U975 utilizes the 2-kV winding of T948 to generate 12 kV to drive the crt anode. It also uses an internal half-wave rectifier diode to produce  $-2$  kV for the crt cathode. The  $-2$  kV supply is filtered by a low-pass filter composed of C975, C976, R976, R978, and C979. Neon lamp DS870 protects against excessive voltage between the crt heater and crt cathode by conducting if the voltage exceeds approximately 75 V.

### Focus Circuit

Focus voltage is also developed from the  $-2$  kV supply via a voltage divider composed of R894, R892, FOCUS potentiometer R893, R891, R890, R889, R888, and Q885. The focus voltage tracks the A-intensity level through the action

of Q885. The emitter voltage of Q804, set by the A INTENSITY control, is applied to the emitter of Q885 through R885. When the emitter voltage of Q804 changes, the current through Q885 changes proportionally and alters the voltage at one end of FOCUS control R893.

### Low-Voltage Supplies

The low-voltage supplies utilize center-tapped secondary windings of T948. The +100 V supply uses CR954 and CR955 for rectification and C954 for filtering. Diodes CR956 and CR957 rectify ac from taps on the 100 V winding, and C956 filters the output to produce +30 V dc. The diode bridge consisting of CR960, CR961, CR962, and CR963 produces the +8.6 V and -8.6 V supplies. Filtering of the +8.6 V is accomplished by C960, C962, and L960; filtering of the -8.6 V is done by C961, C963, and L961. The +5.2

V supply is produced by CR967, CR970, C968, R971, and C970.

### Probe Adjust

The Probe Adjust circuitry, shown on diagram 6, utilizes a square-wave generator and a diode switching network to produce a negative-going square-wave signal at PROBE ADJUST connector J9900. Amplifier U985 is configured as a multivibrator with the time constant of R987 and C987 determining the oscillation period. When the output of the multivibrator is at the positive supply voltage, CR988 is forward biased. This reverse biases CR989 and the PROBE ADJUST connector signal is held at ground potential by R990. When the multivibrator output switches states and is at the negative supply voltage, CR988 is reverse biased. Diode CR989 will now be forward biased and the circuit output signal be approximately -0.5 V.

# PERFORMANCE CHECK PROCEDURE

## INTRODUCTION

### PURPOSE

The "Performance Check Procedure" is used to verify the Performance Requirement statements listed in Table 1-1. It is the recommended acceptance check procedure for new instruments.

Instrument performance should be checked after every 2000 hours of operation or once each year, if used infrequently. A more frequent interval may be necessary, if your instrument is subjected to harsh environments or severe usage. The results of these periodic checks will determine the need for readjustment.

Selected procedures may also be used as preliminary troubleshooting aids or to verify instrument performance after repair or component replacement.

### STRUCTURE

This procedure is structured into four major subsections, each of which can be performed independently, to permit checking individual portions of the instrument. At the beginning of each subsection there is an equipment-required list showing only the test equipment necessary for performing the steps in that subsection. In this list, the Item number that follows each piece of equipment corresponds to the Item number listed in Table 4-1.

Also at the beginning of each subsection is a list of all the front-panel control settings required to prepare the instrument for performing Step 1 in that subsection. Each succeeding step within a particular subsection should then be performed, both in the sequence presented and in its entirety, to ensure that control-setting changes will be correct for ensuing steps.

### TEST EQUIPMENT

The test equipment listed in Table 4-1 is a complete list of the equipment required to accomplish both the "Performance Check Procedure" in this section and the "Adjustment Procedure" in Section 5. To assure accurate measurements, it is important that test equipment used for making these checks meet or exceed the specifications described in Table 4-1. When considering use of equipment other than that recommended, utilize the "Minimum Specification" column to determine whether available test equipment will suffice.

Each procedure in this section is written using the control and connector nomenclature imprinted on the "recommended" test equipment. When substitute equipment is used, control settings stated in the test setup and in the procedure itself may need to be altered.

Detailed operating instructions for test equipment are not given in this procedure. If more operating information is required, refer to the appropriate test-equipment instruction manual.

### LIMITS AND TOLERANCES

The tolerances given in this procedure are valid for an instrument that is operating in and has been previously calibrated in an ambient temperature between +20°C and +30°C. The instrument also must have had at least a 20-minute warm-up period. Refer to Table 1-1 for tolerances applicable to an instrument that is operating outside this temperature range. All tolerances specified are for the instrument only and do not include test-equipment error.

## PREPARATION FOR CHECKS

It is not necessary to remove the instrument cover to accomplish any subsection in the "Performance Check Procedure", since all checks are made using operator-accessible front- and rear-panel controls and connectors.

Test equipment items 1 through 8 in Table 4-1 are required to accomplish the complete Performance Check Procedure.

Before performing any procedure in this section, set the POWER switch to ON and allow a 20-minute warm-up period.

The most accurate display adjustments are made with a stable, well-focused, low-intensity display. Unless otherwise noted, adjust the INTENSITY, FOCUS, and TRIGGER LEVEL controls as needed to view the display.

**Table 4-1**  
**Test Equipment Required**

Item No. and Description	Minimum Specification	Purpose	Examples of Suitable Test Equipment
1. Calibration Generator	Standard-amplitude signal levels: 10 mV to 50 V. Accuracy: $\pm 0.3\%$ .  High-amplitude signal levels: 1 V to 60 V. Repetition rate: 1 kHz.  Fast-rise signal level: 1V. Repetition rate: 1 MHz Rise time: 1 ns or less Flatness: $\pm 0.5\%$ .	Vertical and horizontal checks and adjustments.	TEKTRONIX PG 506 Calibration Generator. <sup>a</sup>
2. Leveled Sine-Wave Generator	Frequency: 250 kHz to above 100 MHz. Output amplitude: variable from 10 mV to 5 V p-p. Output impedance: 50 $\Omega$ . Reference frequency: 50 kHz. Amplitude accuracy: constant within 3% of reference frequency as output frequency changes.	Vertical, horizontal, and triggering checks and adjustments. Display adjustment and Z-Axis check.	TEKTRONIX SG 503 Leveled Sine-Wave Generator. <sup>a</sup>
3. Time-Mark Generator	Marker outputs: 10 ns to 0.5 s. Marker accuracy: $\pm 0.1\%$ . Trigger output: 1 ms to 0.1 $\mu$ s, time-coincident with markers.	Horizontal checks and adjustments. Display adjustment.	TEKTRONIX TG 501 Time-Mark Generator. <sup>a</sup>
4. Cable (2 required)	Impedance: 50 $\Omega$ . Length: 42 in. Connectors: BNC.	Signal interconnection.	Tektronix Part Number 012-0057-01.
5. Termination (2 required)	Impedance: 50 $\Omega$ . Connectors: BNC.	Signal termination.	Tektronix Part Number 011-0049-01.
6. Dual-Input Coupler	Connectors: BNC-Female-to-Dual-BNC male.	Vertical checks and adjustments	Tektronix Part Number 067-0525-01.
7. 10X Attenuator	Ratio: 10X. Impedance: 50 $\Omega$ . Connectors: BNC.	Vertical compensation and triggering checks.	Tektronix Part Number 011-0059-02.

Table 4-1 (cont)

Item No. and Description	Minimum Specification	Purpose	Examples of Suitable Test Equipment
8. T-Connector	Connectors: BNC.	Signal interconnection.	Tektronix Part Number 103-0030-00.
9. Adapter	Connectors: BNC-Male-to-Miniature Probe Tip.	Signal interconnection.	Tektronix Part Number 013-0084-02.
10. Digital Voltmeter	Range: 0 to 140 V. Dc voltage accuracy: $\pm 0.15\%$ . 4 1/2-digit display.	Power supply checks and adjustment. Vertical adjustment.	TEKTRONIX DM 501A Digital Multimeter. <sup>a</sup>
11. Test Oscilloscope with included 10X Probe	Bandwidth: dc to 10 MHz. Minimum deflection factor: 5 mV/div. Accuracy: $\pm 3\%$ .	Holdoff check and general troubleshooting.	TEKTRONIX 2213 Oscilloscope.
12. DC Voltmeter	Range: 0 to 2500 V, calibrated to 1% accuracy at -2000 V.	High-voltage power supply check.	Triplett Model 630-NA.
13. Screwdriver	Length: 3-in shaft. Bit Size: 3/32 in.	Adjust variable resistors.	Xcelite R-3323.
14. Low-Capacitance Alignment Tool	Length: 1-in shaft. Bit size: 3/32 in.	Adjust variable capacitors.	J.F.D. Electronics Corp. Adjustment Tool Number 5284.

<sup>a</sup>Requires a TM 500-series power-module mainframe.

**INDEX TO PERFORMANCE CHECK STEPS**

**Page**

**Vertical**

**Page**

- 1. Check Deflection Accuracy and Variable Range . 4-4
- 2. Check Position Range . . . . . 4-4
- 3. Check Trigger View Gain . . . . . 4-5
- 4. Check Aberrations . . . . . 4-5
- 5. Check Bandwidth . . . . . 4-5
- 6. Check Bandwidth Limit Operation . . . . . 4-6
- 7. Check Common-Mode Rejection Ratio . . . . . 4-6
- 8. Check Channel Isolation . . . . . 4-7

**Horizontal**

- 1. Check Timing Accuracy and Linearity . . . . . 4-8
- 2. Check Variable Range and Sweep Separation . . 4-9
- 3. Check Delay Time Dial Range and Accuracy . . . 4-10

- 4. Check Delay Jitter . . . . . 4-11
- 5. Check Position Range . . . . . 4-11
- 6. Check X Gain . . . . . 4-11
- 7. Check X Bandwidth . . . . . 4-11
- 8. Check Sweep Length . . . . . 4-11

**Trigger**

- 1. Check Internal Triggering . . . . . 4-12
- 2. Check External Triggering . . . . . 4-13
- 3. Check External Trigger Ranges . . . . . 4-13
- 4. Check Single Sweep Operation . . . . . 4-14

**External Z-Axis and Probe Adjust**

- 1. Check External Z-Axis Operation . . . . . 4-15
- 2. Check Probe Adjust Operation . . . . . 4-15

# VERTICAL

**Equipment Required (see Table 4-1):**

Calibration Generator (Item 1)	50-Ω BNC Termination (Item 5)
Leveled Sine-Wave Generator (Item 2)	Dual-Input Coupler (Item 6)
50-Ω BNC Cable (Item 4)	10X Attenuator (Item 7)

## INITIAL CONTROL SETTINGS

### Vertical (Both Channels)

POSITION	Midrange
VERTICAL MODE	CH 1
BW LIMIT	On (button in)
VOLTS/DIV	2 mV
VOLTS/DIV Variable	CAL detent
INVERT	Off (button out)
AC-GND-DC	DC

### Horizontal

POSITION	Midrange
HORIZONTAL MODE	A
A SEC/DIV	0.2 ms
SEC/DIV Variable	CAL detent
X10 Magnifier	Off (knob in)

### A TRIGGER

VAR HOLDOFF	NORM
Mode	P-P AUTO
SLOPE	OUT
LEVEL	Midrange
A&B INT	VERT MODE
A SOURCE	INT
A EXT COUPLING	AC

c. Move the cable from the CH 1 OR X input connector to the CH 2 OR Y input connector. Set the VERTICAL MODE switch to CH 2.

**Table 4-2**  
**Deflection Accuracy Limits**

VOLTS/DIV Switch Setting	Standard Amplitude Signal	Vertical Deflection (Divisions)	Accuracy Limits (Divisions)
2 mV	10 mV	5	4.90 to 5.10
5 mV	20 mV	4	3.92 to 4.08
10 mV	50 mV	5	4.90 to 5.10
20 mV	0.1 V	5	4.90 to 5.10
50 mV	0.2 V	4	3.92 to 4.08
0.1 V	0.5 V	5	4.90 to 5.10
0.2 V	1 V	5	4.90 to 5.10
0.5 V	2 V	4	3.92 to 4.08
1 V	5 V	5	4.90 to 5.10
2 V	10 V	5	4.90 to 5.10
5 V	20 V	4	3.92 to 4.08

## PROCEDURE STEPS

### 1. Check Deflection Accuracy and Variable Range

a. Connect the standard-amplitude generator output via a 50-Ω cable to the CH 1 OR X input connector.

b. CHECK—Deflection accuracy is within the limits given in Table 4-2 for each CH 1 VOLTS/DIV switch setting and corresponding standard-amplitude signal. When at the 20-mV VOLTS/DIV switch setting, rotate the CH 1 VOLTS/DIV Variable control fully counterclockwise and CHECK that the display decreases to 2 divisions or less. Then return the CH 1 VOLTS/DIV Variable control to the CAL detent and continue with the 50-mV check.

d. Repeat part b using the Channel 2 controls.

### 2. Check Position Range

a. Set:

VOLTS/DIV (both)	50 mV
AC-GND-DC (both)	AC

b. Set the generator to produce a 0.5-V standard-amplitude signal.

c. Adjust the CH 2 VOLTS/DIV Variable control to produce a 4.4-division display. Set the CH 2 VOLTS/DIV switch to 10 mV.

d. CHECK—The bottom and top of the trace may be positioned above and below the center horizontal graticule line by rotating the Channel 2 POSITION control fully clockwise and counterclockwise respectively.

e. Move the cable from the CH 2 OR Y input connector to the CH 1 OR X input connector and set the VERTICAL MODE switch to CH 1.

f. Repeat parts c and d using the Channel 1 controls.

### 3. Check Trigger View Gain

a. Set:

Vertical POSITION (both)	Midrange
VOLTS/DIV (both)	0.1 V
VOLTS/DIV Variable (both)	CAL detent

b. While holding in the TRIG VIEW button, use the A TRIGGER LEVEL control to vertically center the display.

c. CHECK—Display amplitude is 4 to 6 divisions while holding in the TRIG VIEW button.

d. Move the cable from the CH 1 OR X input connector to the CH 2 OR Y input connector.

e. Repeat parts b and c.

f. Move the cable from the CH 2 OR Y input connector to the EXT INPUT connector. Set the A SOURCE switch to EXT.

g. Repeat parts b and c.

h. Set the A EXT COUPLING switch to DC.

i. Repeat parts b and c.

j. Set the A EXT COUPLING switch to DC ÷ 10.

k. Set the generator to produce a 5-V signal.

l. Repeat parts b and c.

m. Disconnect the test equipment from the instrument.

### 4. Check Aberrations

a. Set:

BW LIMIT	Off (button out)
VOLTS/DIV (both)	2 mV
AC-GND-DC (both)	DC
A SEC/DIV	0.05 $\mu$ s

b. Connect the fast-rise, positive-going square-wave output via a 50- $\Omega$  cable, a 10X attenuator, and a 50- $\Omega$  termination to the CH 1 OR X input connector.

c. Set the generator to produce a 1-MHz, 5-division display.

d. CHECK—Display aberrations are within 4% (0.2 division or less).

e. Repeat part d for each of the following VOLTS/DIV switch settings: 5 mV through 0.5 V. Adjust the generator output and attach or remove the 10X attenuator as necessary to maintain a 5-division display at each VOLTS/DIV switch setting.

f. Disconnect the cable from the CH 1 OR X input connector. Reconnect the 10X attenuator (if previously removed) and reduce the generator amplitude to minimum.

g. Connect the cable to the CH 2 OR Y input connector and set the VERTICAL MODE switch to CH 2.

h. Set the generator to produce a 5-division display.

i. Repeat parts d and e using the Channel 2 controls.

j. Disconnect the test equipment from the instrument.

### 5. Check Bandwidth

a. Set:

VOLTS/DIV (both)	2 mV
A SEC/DIV	20 $\mu$ s

## Performance Check Procedure—2235 Service

b. Connect the leveled sine-wave generator output via a 50- $\Omega$  cable and a 50- $\Omega$  termination to the CH 2 OR Y input connector.

c. Set the generator to produce a 50-kHz, 6-division display.

d. CHECK—Display amplitude is 4.2 divisions or greater as the generator output frequency is increased up to the value shown in Table 4-3 for the corresponding VOLTS/DIV switch setting.

**Table 4-3**  
**Settings for Bandwidth Checks**

VOLTS/DIV Switch Setting	Generator Output Frequency
2 mV	90 MHz
5 mV to 5 V	100 MHz

e. Repeat parts c and d for all indicated CH 2 VOLTS/DIV switch settings, up to the output-voltage upper limit of the sine-wave generator being used.

f. Move the cable from the CH 2 OR Y input connector to the CH 1 OR X input connector. Set the VERTICAL MODE switch to CH 1.

g. Repeat parts c and d for all indicated CH 1 VOLTS/DIV switch settings, up to the output-voltage upper limit of the sine-wave generator being used.

### 6. Check Bandwidth Limit Operation

a. Set:

BW LIMIT	On (button in)
CH 1 VOLTS/DIV	10 mV
A SEC/DIV	20 $\mu$ s

b. Set the generator to produce a 50-kHz, 6-division display.

c. Increase the generator output frequency until the display amplitude decreases to 4.2 divisions.

d. CHECK—Generator output frequency is between 18 and 22 MHz.

e. Disconnect the test equipment from the instrument.

### 7. Check Common-Mode Rejection Ratio

a. Set:

BW LIMIT	Off (button out)
CH 2 VOLTS/DIV	10 mV
INVERT	On (button in)

b. Connect the leveled sine-wave generator output via a 50- $\Omega$  cable, a 50- $\Omega$  termination, and a dual-input coupler to the CH 1 OR X and the CH 2 OR Y input connectors.

c. Set the generator to produce a 50-MHz, 6-division display.

d. Vertically center the display using the Channel 1 POSITION control. Then set the VERTICAL MODE switch to CH 2 and vertically center the display using the Channel 2 POSITION control.

e. Set the VERTICAL MODE switches to BOTH and ADD.

f. CHECK—Display amplitude is 0.6 division or less.

g. If the check in part f meets the requirement, skip to part p. If it does not, continue with part h.

h. Set the VERTICAL MODE switch to CH 1.

i. Set the generator to produce a 50-kHz, 6-division display.

j. Set the VERTICAL MODE switch to BOTH.

k. Adjust the CH 1 or CH 2 VOLTS/DIV Variable control for minimum display amplitude.

l. Set the VERTICAL MODE switch to CH 1.

m. Set the generator to produce a 50-MHz, 6-division display.

n. Set the VERTICAL MODE switch to BOTH.

- o. CHECK—Display amplitude is 0.6 division or less.
- p. Disconnect the test equipment from the instrument.

- c. Set the generator to produce a 50-MHz, 5-division display.
- d. Set the VERTICAL MODE switch to CH 2.
- e. CHECK—Display amplitude is 0.05 division or less.

**8. Check Channel Isolation**

a. Set:

VERTICAL MODE	CH 1
VOLTS/DIV (both)	1 V
VOLTS/DIV Variable (both)	CAL detent
INVERT	Off (button out)
Channel 2 AC-GND-DC	GND
A SEC/DIV	0.1 $\mu$ s

b. Connect the leveled sine-wave generator output via a 50- $\Omega$  cable and a 50- $\Omega$  termination to the CH 1 OR X input connector.

f. Move the cable from the CH 1 OR X input connector to the CH 2 OR Y input connector.

g. Set:

VERTICAL MODE	CH 1
Channel 1 AC-GND-DC	GND
Channel 2 AC-GND-DC	DC

h. CHECK—Display amplitude is 0.05 division or less.

i. Disconnect the test equipment from the instrument.

# HORIZONTAL

**Equipment Required (see Table 4-1):**

Calibration Generator (Item 1)	50-Ω BNC Cable (Item 4)
Leveled Sine-Wave Generator (Item 2)	50-Ω BNC Termination (Item 5)
Time-Mark Generator (Item 3)	

**INITIAL CONTROL SETTINGS**

**Vertical**

POSITION (both)	Midrange
VERTICAL MODE	CH 1
BW LIMIT	Off (button out)
CH 1 VOLTS/DIV	0.5 V
CH 1 VOLTS/DIV Variable	CAL detent
Channel 1 AC-GND-DC	DC

**Horizontal**

POSITION	Midrange
HORIZONTAL MODE	A
A SEC/DIV	0.05 μs
SEC/DIV Variable	CAL detent
X10 Magnifier	Off (knob in)
B DELAY TIME	
POSITION	Fully counterclockwise

**B TRIGGER**

SLOPE	OUT
LEVEL	Fully clockwise

**A TRIGGER**

VAR HOLDOFF	NORM
Mode	NORM
SLOPE	OUT
LEVEL	Midrange
A&B INT	VERT MODE
A SOURCE	INT
A EXT COUPLING	DC ÷ 10

**PROCEDURE STEPS**

**1. Check Timing Accuracy and Linearity**

a. Connect the time-mark generator output via a 50-Ω cable and a 50-Ω termination to the CH 1 OR X input connector.

b. Select 50-ns time markers from the time-marker generator.

c. Adjust the A TRIGGER LEVEL control for a stable, triggered display.

d. Use the Horizontal POSITION control to align the second time marker with the second vertical graticule line.

e. CHECK—Timing accuracy is within 2% (0.16 division at the 10th vertical graticule line), and linearity is within 5% (0.1 division over any 2 of the center 8 divisions).

**Table 4-4**  
**Settings for Timing Accuracy Checks**

SEC/DIV Switch Setting	Time-Mark Generator Setting	
	Normal	X10 Magnified
0.05 $\mu$ s	50 ns	10 ns
0.1 $\mu$ s	0.1 $\mu$ s	10 ns
0.2 $\mu$ s	0.2 $\mu$ s	20 ns
0.5 $\mu$ s	0.5 $\mu$ s	50 ns
1 $\mu$ s	1 $\mu$ s	0.1 $\mu$ s
2 $\mu$ s	2 $\mu$ s	0.2 $\mu$ s
5 $\mu$ s	5 $\mu$ s	0.5 $\mu$ s
10 $\mu$ s	10 $\mu$ s	1 $\mu$ s
20 $\mu$ s	20 $\mu$ s	2 $\mu$ s
50 $\mu$ s	50 $\mu$ s	5 $\mu$ s
0.1 ms	0.1 ms	10 $\mu$ s
0.2 ms	0.2 ms	20 $\mu$ s
0.5 ms	0.5 ms	50 $\mu$ s
1 ms	1 ms	0.1 ms
2 ms	2 ms	0.2 ms
5 ms	5 ms	0.5 ms
10 ms	10 ms	1 ms
20 ms	20 ms	2 ms
50 ms	50 ms	5 ms
A Sweep Only		
0.1 s	0.1 s	10 ms
0.2 s	0.2 s	20 ms
0.5 s	0.5 s	50 ms

**NOTE**

*For checking the timing accuracy of the A SEC/DIV switch settings from 50 ms to 0.5 s, watch the time marker tips only at the 2nd and 10th vertical graticule lines while adjusting the Horizontal POSITION control.*

f. Repeat parts c through e for the remaining A SEC/DIV and time-mark generator setting combinations shown in Table 4-4 under the "Normal" column.

g. Set:

A SEC/DIV                      0.05  $\mu$ s  
X10 Magnifier                On (knob out)

h. Select 10-ns time markers from the time-mark generator.

i. Use the Horizontal POSITION control to align the first time marker that is 25 ns beyond the start of the sweep with the second vertical graticule line.

j. CHECK—Timing accuracy is within 3% (0.24 division at the 10th vertical graticule line), and linearity is within 5% (0.1 division over any 2 of the center 8 divisions). Exclude any portion of the sweep past the 100th magnified division.

k. Repeat parts i and j for the remaining A SEC/DIV and time-mark generator setting combinations shown in Table 4-4 under the "X10 Magnified" column.

l. Set:

HORIZONTAL MODE        B  
A SEC/DIV                    0.1  $\mu$ s  
B SEC/DIV                    0.05  $\mu$ s  
X10 Magnifier                Off (knob in)

m. Repeat parts b through k for the B Sweep. Keep the A SEC/DIV switch one setting slower than the B SEC/DIV switch.

**2. Check Variable Range and Sweep Separation**

a. Set:

HORIZONTAL MODE        A  
A and B SEC/DIV            0.2 ms  
SEC/DIV Variable           Fully counterclockwise  
X10 Magnifier               Off (knob in)  
A TRIGGER Mode            P-P AUTO

b. Select 0.5-ms time markers from the time-mark generator.

c. CHECK—Time markers are 1 division or less apart.

d. Set:

Channel 1 AC-GND-DC      GND  
SEC/DIV Variable            CAL detent  
HORIZONTAL MODE          ALT

e. Use the Channel 1 POSITION control to set the A Sweep at the center horizontal graticule line.

f. CHECK—The B Sweep can be positioned more than 3.5 divisions above and below the A Sweep when the A/B SWP SEP control is rotated fully clockwise and counterclockwise respectively.

**Performance Check Procedure—2235 Service**

**3. Check Delay Time Dial Range and Accuracy**

a. Set the B DELAY TIME POSITION dial fully counterclockwise.

b. Align the start of the A Sweep with the 1st vertical graticule line using the Horizontal POSITION control.

c. CHECK—Intensified portion of the trace starts within 0.5 division of the start of the sweep.

d. Rotate the B DELAY TIME POSITION control fully clockwise.

e. CHECK—Intensified portion of the trace is past the 11th vertical graticule line.

f. Set:

A and B SEC/DIV            0.5  $\mu$ s  
 B DELAY TIME POSITION    Fully counterclockwise

g. Align the start of the A Sweep with the 1st vertical graticule line using the Horizontal POSITION control.

h. CHECK—Intensified portion of the trace starts within 1.1 divisions of the start of the sweep.

i. Repeat parts d and e.

j. Set:

Channel 1 AC-GND-DC        DC  
 HORIZONTAL MODE            B  
 A SEC/DIV                      0.5  $\mu$ s  
 B SEC/DIV                      0.05  $\mu$ s  
 B DELAY TIME POSITION       1.00

k. Select 5- $\mu$ s time markers from the time-mark generator.

l. Adjust the Horizontal POSITION control so that the top of the first fully displayed time marker is aligned with the center vertical graticule line.

m. Without changing the Horizontal POSITION control setting, set the B DELAY TIME POSITION dial to 9.00. Slightly readjust the B DELAY TIME POSITION dial to align the top of the time marker with the center vertical graticule line.

n. CHECK—The B DELAY TIME POSITION dial setting is between 8.905 and 9.095.

o. Repeat parts l through n for the remaining A and B SEC/DIV and time-mark generator setting combinations shown in Table 4-5.

**Table 4-5  
 Settings for Delay Time Accuracy Checks**

A SEC/DIV Switch Setting	B SEC/DIV Switch Setting	Time-Mark Generator Setting
0.5 $\mu$ s	0.05 $\mu$ s	0.5 $\mu$ s
5 $\mu$ s	0.5 $\mu$ s	5 $\mu$ s
0.5 ms	50 $\mu$ s	0.5 ms
5 ms	0.5 ms	5 ms
0.5 s	50 ms	0.5 s

p. Set:

A SEC/DIV                      0.5 ms  
 B SEC/DIV                      50  $\mu$ s  
 B DELAY TIME POSITION       1.00

q. Select 0.5-ms time markers from the time-mark generator.

r. Adjust the Horizontal POSITION control so that the rising edge of the displayed time marker is aligned with the center vertical graticule line.

s. Without changing the Horizontal POSITION control setting, turn the B DELAY TIME POSITION dial clockwise to position the next time marker leading edge to the center vertical graticule line.

t. CHECK—The B DELAY TIME POSITION dial setting is 0.975 to 1.025 greater than the previous setting.

u. Set the B DELAY TIME POSITION dial to the exact integer setting.

v. Repeat parts r through u for each successive time marker up to the marker corresponding to the B DELAY TIME POSITION dial setting of 10.00.

#### 4. Check Delay Jitter

a. Set:

A SEC/DIV	0.5 ms
B SEC/DIV	0.5 $\mu$ s
B DELAY TIME POSITION	10.00

b. Select 50- $\mu$ s time markers from the time-mark generator.

c. Rotate the B DELAY TIME POSITION control counterclockwise to position a time marker within the graticule area for each major dial division and CHECK that the jitter on the leading edge of the time marker does not exceed 0.5 division. Disregard slow drift.

#### 5. Check Position Range

a. Set:

HORIZONTAL MODE	A
A SEC/DIV	10 $\mu$ s

b. Select 10- $\mu$ s time markers from the time-mark generator.

c. CHECK—Start of the sweep can be positioned to the right of the center vertical graticule line by rotating the Horizontal POSITION control fully clockwise.

d. CHECK—The 11th time marker can be positioned to the left of the center vertical graticule line by rotating the Horizontal POSITION control fully counterclockwise.

e. Select 50- $\mu$ s time markers from the time-mark generator.

f. Align the 3rd time marker with the center vertical graticule line using the Horizontal POSITION control.

g. Set the X10 Magnifier knob to On (knob out).

h. CHECK—Magnified time marker can be positioned to the left of the center vertical graticule line by rotating the Horizontal POSITION control fully counterclockwise.

i. CHECK—Start of the sweep can be positioned to the right of the center vertical graticule line by rotating the Horizontal POSITION control fully clockwise.

j. Disconnect the test equipment from the instrument.

#### 6. Check X Gain

a. Set:

CH 1 VOLTS/DIV	10 mV
Horizontal POSITION	Midrange
A SEC/DIV	X-Y
X10 Magnifier	Off (knob in)

b. Connect the standard-amplitude generator output via a 50- $\Omega$  cable to the CH 1 OR X input connector.

c. Set the generator to produce a 50-mV signal. Vertically center the trace using the Channel 1 POSITION control.

d. CHECK—Display is 4.85 to 5.15 horizontal divisions.

e. Disconnect the test equipment from the instrument.

#### 7. Check X Bandwidth

a. Connect the leveled sine-wave generator output via a 50- $\Omega$  cable and a 50- $\Omega$  termination to the CH 1 OR X input connector.

b. Set the generator to produce a 5-division horizontal display at an output frequency of 50 kHz.

c. Increase the generator output frequency to 3 MHz.

d. CHECK—Display is at least 3.5 horizontal divisions.

e. Disconnect the test equipment from the instrument.

#### 8. Check Sweep Length

a. Set the A SEC/DIV control to 0.1 ms and position the start of the sweep at the first vertical graticule line using the Horizontal POSITION control.

b. CHECK—End of the sweep is to the right of the 11th vertical graticule line.

# TRIGGER

**Equipment Required (see Table 4-1):**

- |                                      |                               |
|--------------------------------------|-------------------------------|
| Leveled Sine-Wave Generator (Item 2) | 50-Ω BNC Termination (Item 5) |
| 50-Ω BNC Cable (Item 4)              |                               |

## INITIAL CONTROL SETTINGS

### Vertical

- |                           |                  |
|---------------------------|------------------|
| POSITION (both)           | Midrange         |
| VERTICAL MODE             | CH 1             |
| BW LIMIT                  | Off (button out) |
| CH 1 VOLTS/DIV            | 5 mV             |
| CH 2 VOLTS/DIV            | 50 mV            |
| VOLTS/DIV Variable (both) | CAL detent       |
| INVERT                    | Off (button out) |
| AC-GND-DC (both)          | DC               |

### Horizontal

- |                  |                        |
|------------------|------------------------|
| POSITION         | Midrange               |
| HORIZONTAL MODE  | A                      |
| A and B SEC/DIV  | 0.2 μs                 |
| SEC/DIV Variable | CAL detent             |
| X10 Magnifier    | Off (knob in)          |
| B DELAY TIME     |                        |
| POSITION         | Fully counterclockwise |

### B TRIGGER

- |       |          |
|-------|----------|
| SLOPE | OUT      |
| LEVEL | Midrange |

### A TRIGGER

- |                |          |
|----------------|----------|
| VAR HOLDOFF    | NORM     |
| Mode           | P-P AUTO |
| SLOPE          | OUT      |
| LEVEL          | Midrange |
| A&B INT        | CH 1     |
| A SOURCE       | INT      |
| A EXT COUPLING | DC       |

## PROCEDURE STEPS

### 1. Check Internal Triggering

a. Connect the leveled sine-wave generator output via a 50-Ω cable and a 50-Ω termination to the CH 1 OR X input connector.

b. Set the generator to produce a 10-MHz, 3-division display.

c. Set the CH 1 VOLTS/DIV switch to 50 mV.

d. CHECK—Stable display can be obtained by adjusting the A TRIGGER LEVEL control for each switch combination given in Table 4-6.

**Table 4-6**  
Switch Combinations for A Triggering Checks

A TRIGGER Mode	A TRIGGER SLOPE
NORM	OUT
NORM	IN
P-P AUTO	IN
P-P AUTO	OUT

e. Set the HORIZONTAL MODE switch to B.

f. CHECK—Stable display can be obtained by adjusting the B TRIGGER LEVEL control in a position other than the B RUNS AFTER DLY position for both the OUT and IN positions of the B TRIGGER SLOPE switch.

g. Set:

- |                 |      |
|-----------------|------|
| VERTICAL MODE   | CH 2 |
| HORIZONTAL MODE | A    |
| A&B INT         | CH 2 |

h. Move the cable from the CH 1 OR X input connector to the CH 2 OR Y input connector.

i. Repeat parts d through f.

j. Set:

- |                 |               |
|-----------------|---------------|
| HORIZONTAL MODE | A             |
| A SEC/DIV       | 0.1 μs        |
| X10 Magnifier   | On (knob out) |

k. Set the generator to produce a 60-MHz, 1.0-division display.

l. Repeat parts d through f.

m. Set:

VERTICAL MODE	CH 1
HORIZONTAL MODE	A
A&B INT	VERT MODE

n. Move the cable from the CH 2 OR Y input connector to the CH 1 OR X input connector.

o. Repeat parts d through f.

p. Set:

HORIZONTAL MODE	A
A SEC/DIV	0.05 $\mu$ S

q. Set the generator to produce a 100-MHz, 1.5-division display.

r. Repeat parts d through f.

s. Set:

VERTICAL MODE	CH 2
HORIZONTAL MODE	A

t. Move the cable from the CH 1 OR X input connector to the CH 2 OR Y input connector.

u. Repeat parts d through f.

v. Disconnect the test equipment from the instrument.

## 2. Check External Triggering

a. Set:

VERTICAL MODE	CH 1
HORIZONTAL MODE	A
X10 Magnifier	Off (knob in)
A SOURCE	EXT

b. Connect a 35-mV, 10-MHz leveled sine-wave signal via a 50- $\Omega$  cable and a 50- $\Omega$  termination to the EXT INPUT connector.

c. Push in and hold the TRIG VIEW button.

d. CHECK—Stable display can be obtained by adjusting the A TRIGGER LEVEL control for each switch combination given in Table 4-6. Then release the TRIG VIEW button.

e. Set the generator output voltage to 120 mV and the frequency to 60 MHz. Set the X10 Magnifier to On (knob out).

f. Repeat parts c and d.

g. Set the generator output voltage to 200 mV and the frequency to 100 MHz.

h. Repeat parts c and d.

i. Disconnect the test equipment from the instrument.

## 3. Check External Trigger Ranges

a. Set:

CH 1 VOLTS/DIV	0.5 V
A SEC/DIV	20 $\mu$ S
X10 Magnifier	Off (knob in)
A TRIGGER Mode	NORM

b. Connect the leveled sine-wave generator output via a 50- $\Omega$  cable, a 50- $\Omega$  termination, and a dual-input coupler to both the CH 1 OR X and EXT INPUT connectors.

c. Set the generator to produce a 50-kHz, 6.4-division display.

d. CHECK—Display is triggered along the entire positive slope of the waveform as the A TRIGGER LEVEL control is rotated.

e. CHECK—Display is not triggered (no trace) at either extreme of rotation.

f. Set the A TRIGGER SLOPE button to IN.

g. CHECK—Display is triggered along the entire negative slope of the waveform as the A TRIGGER LEVEL control is rotated.

## Performance Check Procedure—2235 Service

h. CHECK—Display is not triggered (no trace) at either extreme of rotation.

### 4. Check Single Sweep Operation

a. Adjust the A TRIGGER LEVEL control to obtain a stable display.

b. Set:

Channel 1 AC-GND-DC	GND
A SOURCE	INT

c. Press in the SGL SWP button. The READY LED should illuminate and remain on.

d. Set the Channel 1 AC-GND-DC switch to DC.

e. CHECK—READY LED goes out and a single sweep occurs.

#### NOTE

*The A INTENSITY control may require adjustment to observe the single-sweep trace.*

f. Press in the SGL SWP button several times.

g. CHECK—Single-sweep trace occurs, and the READY LED illuminates briefly every time the SGL SWP button is pressed in and released.

h. Disconnect the test equipment from the instrument.

# EXTERNAL Z-AXIS AND PROBE ADJUST

## Equipment Required (see Table 4-1):

Leveled Sine-Wave Generator (Item 2)

Two 50- $\Omega$  BNC Cables (Item 4)

50- $\Omega$  BNC Termination (Item 5)

BNC T-Connector (Item 8)

10X Probe (provided with instrument)

## INITIAL CONTROL SETTINGS

### Vertical

Channel 1 POSITION	Midrange
VERTICAL MODE	CH 1
BW LIMIT	Off (button out)
CH 1 VOLTS/DIV	1 V
CH 1 VOLTS/DIV Variable	CAL detent
Channel 1 AC-GND-DC	DC

### Horizontal

POSITION	Midrange
HORIZONTAL MODE	A
A SEC/DIV	20 $\mu$ s
SEC/DIV Variable	CAL detent
X10 Magnifier	Off (knob in)

### A TRIGGER

VAR HOLDOFF	NORM
Mode	P-P AUTO
SLOPE	OUT
LEVEL	Midrange
A&B INT	VERT MODE
A SOURCE	INT

## PROCEDURE STEPS

### 1. Check External Z-Axis Operation

a. Connect the leveled sine-wave generator output via a 50- $\Omega$  cable and a T-connector to the CH 1 OR X input con-

connector. Then connect a 50- $\Omega$  cable and a 50- $\Omega$  termination from the T-connector to the EXT Z AXIS INPUT connector on the rear panel.

b. Set the generator to produce a 5-V, 50-kHz signal.

c. CHECK—For noticeable intensity modulation. The positive part of the sine wave should be of lower intensity than the negative part.

d. Disconnect the test equipment from the instrument.

### 2. Check Probe Adjust Operation

a. Set:

CH 1 VOLTS/DIV	10 mV
A SEC/DIV	0.5 ms

b. Connect the 10X Probe to the CH 1 OR X input connector and insert the probe tip into the PROBE ADJUST jack on the instrument front panel. If necessary, adjust the probe compensation for a flat-topped square-wave display.

c. CHECK—Display amplitude is 4.75 to 5.25 divisions.

d. Disconnect the probe from the instrument.

# ADJUSTMENT PROCEDURE

## INTRODUCTION

### PURPOSE

The "Adjustment Procedure" is a set of logically sequenced instructions intended to return the instrument to conformance with the Performance Requirement statements listed in Table 1-1. Adjustments contained in this procedure should only be performed after checks from the "Performance Check Procedure" (Section 4) have indicated a need for readjustment or after repairs have been made to the instrument.

Table 4-1. When considering use of equipment other than that recommended, utilize the "Minimum Specification" column to determine whether available test equipment will suffice.

Detailed operating instructions for test equipment are not given in this procedure. If more operating information is required, refer to the appropriate test-equipment instruction manual.

### STRUCTURE

This procedure is structured into four major subsections, each of which can be performed independently to permit adjustment of individual sections of the instrument. For example, if only the Vertical section fails to meet the Performance Requirements or has had repairs made, it can be readjusted with little or no effect on other sections of the instrument.

The Power Supply section, however, affects all other sections of the instrument. Therefore, if repairs or readjustments have been made that change the absolute value of any of the supply voltages, the entire Adjustment Procedure should be performed.

At the beginning of each subsection is a list of all the front-panel control settings required to prepare the instrument for performing Step 1 in that subsection. Each succeeding step within a subsection should be performed in sequence and in its entirety to ensure that control settings will be correct for ensuing steps. All steps within a subsection should be completed.

### TEST EQUIPMENT

The test equipment listed in Table 4-1 is a complete list of the equipment required to accomplish both the "Performance Check Procedure" in section 4 and the "Adjustment Procedure" in this section. To assure accurate measurements, it is important that test equipment used for making these checks meet or exceed the specifications described in

### LIMITS AND TOLERANCES

The limits and tolerances stated in this procedure are instrument specifications only if they are listed in the "Performance Requirements" column of Table 1-1. Tolerances given are applicable only to the instrument undergoing adjustment and do not include test equipment error. Adjustment of the instrument must be accomplished at an ambient temperature between +20°C and +30°C, and the instrument must have had a warm-up period of at least 20 minutes.

### ADJUSTMENT INTERACTION

Some adjustments interact with and affect other adjustment settings. Table 5-1 identifies these interaction areas. Refer to this table if a partial procedure is performed or if a circuit requires readjustment due to a component replacement. To use Table 5-1, first find the adjustment that was made (extreme left column). Then move to the right, across the row, until you come to a darkened square. From the darkened square, move up the column to find the interactive adjustment. Check the accuracy and, if necessary, readjust the adjustment.

### PREPARATION FOR ADJUSTMENT

The instrument cabinet must be removed to perform the Adjustment Procedure. See the "Cabinet" remove and replace instructions located in the "Maintenance" section of the manual.

**Adjustment Procedure—2235 Service**

All test equipment items listed in Table 4-1 are required to accomplish a complete Adjustment Procedure. At the beginning of each subsection there is an equipment-required list showing only the test equipment necessary for performing the steps in that subsection. In this list, the item number following each piece of equipment corresponds to the item number listed in Table 4-1.

Before performing this procedure, do not preset any internal adjustments and do not change the -8.6-V power-supply adjustment. Altering this adjustment may necessitate a complete readjustment of the instrument, whereas only a partial adjustment might otherwise be required. Only change

an internal adjustment setting if a Performance Characteristic cannot be met with the original setting. If it is necessary to change the setting of an internal adjustment, check Table 5-1 for possible adjustment interactions.

Before performing any procedure in this section, set the POWER switch to ON and allow a 20-minute warm-up period.

The most accurate display adjustments are made with a stable, well-focused, low-intensity display. Unless otherwise noted, adjust the INTENSITY, FOCUS, and TRIGGER LEVEL controls as needed to view the display.

**Table 5-1  
Adjustment Interactions**

Adjustments or Replacements Made	Adjustments Affected																		
	TRACE ALIGNMENT	GEOMETRY	2/5mV DC BALANCE	CH 1 VAR BALANCE	MF/LF GAIN BAL & FREQ COMP	VERTICAL GAIN	ATTENUATOR COMP	DELAY LINE COMP	CH 2 HIGH FREQ MATCH	HORIZ GAIN	HORIZ X10 GAIN	MAGNIFIER REGISTRATION	DELAY DIAL TIMING	HIGH-SPEED TIMING	5ns TIMING AND LINEARITY	TRIGGER OFFSET	TRIGGER SENSITIVITY	SLOPE BALANCE	P-P AUTO TRIGGER CENTERING
-8.6V POWER SUPPLY	■	■	■	■	■	■	■	■	■	■	■	■	■	■	■	■	■	■	■
TRACE ALIGNMENT	■																		
GEOMETRY		■																	
2/5mV DC BALANCE			■																
CH 1 VAR BALANCE				■															
MF/LF GAIN BAL & FREQ COMP					■														
VERTICAL GAIN						■													
ATTENUATOR COMP							■												
DELAY LINE COMP								■											
CH 2 HIGH FREQ MATCH									■										
HORIZ GAIN										■									
HORIZ X10 GAIN											■								
MAGNIFIER REGISTRATION												■							
DELAY DIAL TIMING													■						
HIGH-SPEED TIMING														■					
5ns TIMING AND LINEARITY															■				
TRIGGER OFFSET																■			
TRIGGER SENSITIVITY																	■		
SLOPE BALANCE																		■	
P-P AUTO TRIGGER CENTERING																			■
CRT REPLACEMENT	■	■	■	■	■	■	■	■	■	■	■	■	■	■	■	■	■	■	■

4206-20

## INDEX TO ADJUSTMENT PROCEDURE STEPS

<b>Power Supply and CRT Display</b>	<b>Page</b>
1. Check/Adjust Power Supply DC Levels	5-4
2. Check High-Voltage Supply	5-5
3. Adjust CRT Grid Bias	5-5
4. Adjust Astigmatism	5-5
5. Adjust Trace Alignment	5-5
6. Adjust Geometry	5-5
<b>Vertical</b>	
1. Adjust Attenuator Step Balance	5-6
2. Adjust 2/5 mV DC Balance	5-7
3. Adjust Channel 1 Variable Balance	5-7
4. Adjust Channel 2 Invert Balance	5-7
5. Adjust MF/LF Compensation and Gain Balance	5-7
6. Adjust Vertical Gain	5-8
7. Check Deflection Accuracy and Variable Range	5-8
8. Check Input Coupling	5-8
9. Adjust Attenuator Compensation	5-9
10. Check Alternation Operation	5-10
11. Check Chop Operation	5-10
12. Adjust High-Frequency Peaking Compensation, Delay Line Compensation, and Channel 2 High- Frequency Compensation	5-10
13. Adjust 2-mV Peaking Compensation	5-11
14. Check Trigger View Gain	5-11
15. Check Position Range	5-11
16. Check Bandwidth Limit Operation	5-12
17. Check Bandwidth	5-12
18. Check Channel Isolation	5-12
19. Check Common-Mode Rejection Ratio	5-13
20. Check Input Gate Current	5-13

<b>Horizontal</b>	<b>Page</b>
1. Adjust Horizontal Amplifier Gain	5-14
2. Adjust X10 Horizontal Amplifier Gain	5-15
3. Adjust Magnifier Registration	5-15
4. Check Sweep Length	5-15
5. Check Position Range	5-15
6. Check Variable Range	5-15
7. Adjust Delay Dial Timing	5-16
8. Adjust High-Speed Timing	5-16
9. Adjust 5-ns Timing and Linearity	5-16
10. Check Timing Accuracy and Linearity	5-16
11. Check Delay Time Dial Range and Accuracy	5-17
12. Check Delay Jitter	5-18
13. Check Sweep Separation	5-19
14. Adjust X Gain	5-19
15. Check X Bandwidth	5-19
16. Check A-Sweep Holdoff	5-19

### Trigger

1. Adjust Trigger Offset	5-20
2. Adjust Trigger Sensitivity	5-20
3. Adjust Slope Balance	5-21
4. Adjust P-P Auto Trigger Centering	5-21
5. Check Internal Triggering	5-21
6. Check External Triggering	5-22
7. Check External Trigger Ranges	5-22
8. Check Single Sweep Operation	5-23

### External Z-Axis and Probe Adjust

1. Check External Z-Axis Operation	5-24
2. Check Probe Adjust Operation	5-24

# POWER SUPPLY AND CRT DISPLAY

**Equipment Required (See Table 4-1):**

Leveled Sine-Wave Generator (Item 2)	Digital Voltmeter (Item 10)
Time-Mark Generator (Item 3)	DC Voltmeter (Item 12)
50-Ω BNC Cable (Item 4)	Screwdriver (Item 13)
50-Ω BNC Termination (Item 5)	

See **ADJUSTMENT LOCATIONS 1**

at the back of this manual for location of test points and adjustments.

## INITIAL CONTROL SETTINGS

### Vertical

POSITION (both)	Midrange
VERTICAL MODE	CH 1
CH 1 VOLTS/DIV	5 mV
CH 1 VOLTS/DIV Variable	CAL detent
Channel 1 AC-GND-DC	GND

### Horizontal

POSITION	Midrange
HORIZONTAL MODE	A
A SEC/DIV	X-Y
SEC/DIV Variable	CAL detent
X10 Magnifier	Off (knob in)

### A TRIGGER

VAR HOLDOFF	NORM
Mode	P-P AUTO
SLOPE	OUT
LEVEL	Midrange
A&B INT	VERT MODE
A SOURCE	INT

## PROCEDURE STEPS

### 1. Check/Adjust Power Supply DC Levels (R938)

**NOTE**

Review the information at the beginning of the Adjustment Procedure before starting this step.

a. Connect the digital voltmeter low lead to chassis ground and connect the volts lead to the  $-8.6\text{-V}$  supply (TP961).

b. CHECK—Voltmeter reading is  $-8.56$  to  $-8.64$  V. If the reading is within these limits, skip to part d.

c. ADJUST—The  $-8.6$  V Adj potentiometer (R938) for a voltmeter reading of  $-8.6$  V.

d. CHECK—Voltage levels of the remaining power supplies listed in Table 5-2 are within the specified limits.

**Table 5-2  
Power Supply Limits**

Power Supply	Test Point	Reading (Volts)
$-8.6$ V	TP961	$-8.56$ to $-8.64$
$+5.2$ V	W968	$+5.04$ to $+5.36$
$+8.6$ V	W960	$+8.43$ to $+8.77$
$+30$ V	W956	$+29.1$ to $+30.9$
$+100$ V	W954	$+97.0$ to $+103.0$

e. Disconnect the test equipment from the instrument.

## 2. Check High-Voltage Supply

**WARNING**

*Instrument must be turned off when removing or replacing the crt cover and cap.*

a. Remove the crt cover and cap and connect a dc voltmeter capable of measuring at least  $-2500$  V between pin 2 of the crt socket and chassis ground. Pin 2 of the crt is negative with respect to the chassis.

b. CHECK—Voltmeter reading is between  $-1900$  V and  $-2100$  V.

c. Disconnect the voltmeter leads and replace the crt cap and cover.

## 3. Adjust CRT Grid Bias (R851)

a. Connect a  $50\text{-}\Omega$  termination to the EXT Z AXIS INPUT connector located on the rear panel.

b. Adjust the front-panel FOCUS control to produce a well-defined dot.

c. Rotate the A INTENSITY control fully counter clockwise.

d. ADJUST—Grid Bias (R851) for a visible dot. Then back off the Grid Bias potentiometer until the dot just disappears.

e. Disconnect the  $50\text{-}\Omega$  termination from the EXT Z AXIS INPUT connector.

## 4. Adjust Astigmatism (R874)

a. Set:

A INTENSITY	Visible display
CH 1 VOLTS/DIV	5 mV
Channel 1 AC-GND-DC	DC
A SEC/DIV	5 $\mu$ s

b. Connect  $50\text{-}\mu$ s time markers from the time-mark generator via a  $50\text{-}\Omega$  cable and a  $50\text{-}\Omega$  termination to the CH 1 OR X input connector.

c. Set the generator to produce a 50-kHz, 4-division display.

d. ADJUST—Astig (R874) and the front-panel FOCUS control for the best defined waveform.

e. Disconnect the test equipment from the instrument.

## 5. Adjust Trace Alignment

a. Position the trace to the center horizontal graticule line.

b. ADJUST—The front-panel TRACE ROTATION control for optimum alignment of the trace with the center horizontal graticule line.

## 6. Adjust Geometry (R870)

a. Set:

CH 1 VOLTS/DIV	50 mV
A SEC/DIV	0.1 ms

b. Connect  $50\text{-}\mu$ s time markers from the time-mark generator via a  $50\text{-}\Omega$  cable and a  $50\text{-}\Omega$  termination to the CH 1 OR X input connector.

c. Adjust the Channel 1 POSITION control to position the baseline part of the display below the bottom horizontal graticule line.

d. Adjust the SEC/DIV Variable control for 5 markers per division.

e. ADJUST—Geom (R870) for minimum curvature of the time markers at the left and right edges of the graticule.

f. Set the Channel 1 AC-GND-DC switch to GND.

g. ADJUST—Geom (R870) for minimum curvature of the baseline trace when positioned at the top and bottom horizontal graticule lines using the Channel 1 POSITION control.

h. Set the Channel 1 AC-GND-DC switch to DC.

i. Repeat parts e through h for optimum compromise between the vertical and horizontal displays.

j. Disconnect the test equipment from the instrument.

# VERTICAL

**Equipment Required (See Table 4-1):**

Calibration Generator (Item 1)	10X Attenuator (Item 7)
Leveled Sine-Wave Generator (Item 2)	Adapter (Item 9)
50-Ω BNC Cable (Item 4)	Screwdriver (Item 13)
50-Ω BNC Termination (Item 5)	Low-Capacitance Alignment Tool (Item 14)
Dual-Input Coupler (Item 6)	10X Probe (included with instrument)

See **ADJUSTMENT LOCATIONS 1** and **ADJUSTMENT LOCATIONS 2**

at the back of this manual for locations of test points and adjustments.

## INITIAL CONTROL SETTINGS

## PROCEDURE STEPS

### Vertical (Both Channels)

POSITION	Midrange
VERTICAL MODE	CH 1
BW LIMIT	On (button in)
VOLTS/DIV	50 mV
VOLTS/DIV Variable	CAL detent
INVERT	Off (button out)
AC-GND-DC	GND

### 1. Adjust Attenuator Step Balance (R10 and R60)

a. Position the trace on the center horizontal graticule line using the Channel 1 POSITION control.

b. Set the CH 1 VOLTS/DIV switch to 5 mV.

c. ADJUST—Ch 1 Step Bal (R10) to set the trace on the center horizontal graticule line.

d. Set the CH 1 VOLTS/DIV switch to 50 mV.

e. Repeat parts a through d until there is no trace shift when changing the CH 1 VOLTS/DIV switch from 50 mV to 5 mV.

f. Set the VERTICAL MODE switch to CH 2.

g. Repeats parts a through e for Channel 2, adjusting Ch 2 Step Bal (R60) in part c.

### Horizontal

POSITION	Midrange
HORIZONTAL MODE	A
A SEC/DIV	0.5 ms
SEC/DIV Variable	CAL detent
X10 Magnifier	Off (knob in)

### A TRIGGER

VAR HOLDOFF	NORM
Mode	P-P AUTO
SLOPE	OUT
LEVEL	Midrange
A&B INT	VERT MODE
A SOURCE	INT
A EXT COUPLING	AC

**2. Adjust 2/5 mV DC Balance (R33 and R83)**

- a. Set the CH 2 VOLTS/DIV switch to 5 mV.
- b. Position the trace on the center horizontal graticule line using the Channel 2 POSITION control.
- c. Set the CH 2 VOLTS/DIV switch to 2 mV.
- d. ADJUST—Ch 2 2/5 mV Dc Bal (R83) to set the trace on the center horizontal graticule line.
- e. Repeat parts a through d until there is no trace shift when changing the CH 2 VOLTS/DIV switch from 5 mV to 2 mV.
- f. Set the VERTICAL MODE switch to CH 1.
- g. Repeat parts a through e for Channel 1, adjusting Ch 1 2/5 mV Dc Bal (R33) in part d.

**3. Adjust Channel 1 Variable Balance (R25)**

- a. Set both VOLTS/DIV switches to 10 mV.
- b. Rotate the CH 1 VOLTS/DIV Variable control fully counterclockwise.
- c. Position the trace on the center horizontal graticule line using the Channel 1 POSITION control.
- d. Rotate the CH 1 VOLTS/DIV Variable control clockwise to the CAL detent.
- e. ADJUST—Ch 1 Var Bal (R25) to set the trace to the center horizontal graticule line.
- f. Repeat parts b through e until there is no trace shift between the fully clockwise and the fully counterclockwise positions of the CH 1 VOLTS/DIV Variable control.
- g. Return the CH 1 VOLTS/DIV Variable control to the CAL detent.

**4. Adjust Channel 2 Invert Balance (R75)**

- a. Set the VERTICAL MODE switch to CH 2.

- b. Position the trace on the center horizontal graticule line using the Channel 2 POSITION control.
- c. Set the INVERT button to On (button in).
- d. ADJUST—Ch 2 Invert Bal (R75) to set the trace to the center horizontal graticule line.
- e. Set the INVERT button to Off (button out).
- f. Repeat parts b through e until there is no trace shift when switching the INVERT button between the On and Off positions.
- g. Repeat Steps 2 and 3 for Channel 1 until no further improvement is noted.
- h. Repeat Steps 2 and 4 for Channel 2 until no further improvement is noted.

**5. Adjust MF/LF Compensation and Gain Balance (C53, R97, C3, and R47).**

- a. Set:

VERTICAL MODE	CH 2
VOLTS/DIV (both)	10 mV
AC-GND-DC (both)	DC
A SEC/DIV	20 $\mu$ s

- b. Connect the high-amplitude square wave output via a 50- $\Omega$  cable, a 10X attenuator, and a 50- $\Omega$  termination to the CH 2 OR Y input connector.
- c. Set the generator to produce a 10-kHz, 5-division display.
- d. Set the top of the display on the center horizontal graticule line using the Channel 2 POSITION control.
- e. ADJUST—Ch 2 MF/LF Comp (C53) and Ch 2 MF/LF Gain Bal (R97) for the best front corner and flat top.
- f. Move the cable from the CH 2 OR Y input connector to the CH 1 OR X input connector. Set the VERTICAL MODE switch to CH 1.
- g. Set the top of the display on the center horizontal graticule line using the Channel 1 POSITION control.

## Adjustment Procedure—2235 Service

h. ADJUST—Ch 1 MF/LF Comp (C3) and Ch 1 MF/LF Gain Bal (R47) for the best front corner and flat top.

i. Disconnect the test equipment from the instrument.

### 6. Adjust Vertical Gain (R145, R195, R76, and R26)

a. Connect a 50-mV standard-amplitude signal via a 50- $\Omega$  cable to the CH 1 OR X input connector.

b. Set the A SEC/DIV switch to 0.2 ms.

c. ADJUST—Ch 1 Gain (R145) for an exact 5-division display.

d. Move the cable from the CH 1 OR X input connector to the CH 2 OR Y input connector. Set the VERTICAL MODE switch to CH 2.

e. ADJUST—Ch 2 Gain (R195) for an exact 5-division display.

f. Change the generator output to 10 mV and set both VOLTS/DIV switches to 2 mV.

g. ADJUST—Ch 2 2-mV Gain (R76) for an exact 5-division display.

h. Move the cable from the CH 2 OR Y input connector to the CH 1 OR X input connector. Set the VERTICAL MODE switch to CH 1.

i. ADJUST—Ch 1 2-mV Gain (R26) for an exact 5-division display.

j. Set both AC-GND-DC switches to GND.

k. CHECK—That no trace shift occurs when switching between the 5 mV and 2 mV positions of the CH 1 VOLTS/DIV switch. If trace shift is observed, repeat Step 2 of this procedure.

l. Set the VERTICAL MODE switch to CH 2.

m. CHECK—That no trace shift occurs when switching between the 5 mV and 2 mV positions of the CH 2

VOLTS/DIV switch. If trace shift is observed, repeat Step 2 of this procedure.

### 7. Check Deflection Accuracy and Variable Range

a. Set:

VERTICAL MODE	CH 1
AC-GND-DC (both)	DC

b. CHECK—Deflection accuracy is within the limits given in Table 5-3 for each CH 1 VOLTS/DIV switch setting and corresponding standard-amplitude signal. When at the 20-mV VOLTS/DIV switch setting, rotate the CH 1 VOLTS/DIV Variable control fully counterclockwise and CHECK that the display decreases to 2 divisions or less. Then return the CH 1 VOLTS/DIV Variable control to the CAL detent and continue with the 50-mV check.

**Table 5-3**  
**Deflection Accuracy Limits**

VOLTS/DIV Switch Setting	Standard Amplitude Signal	Vertical Deflection (Divisions)	Accuracy Limits (Divisions)
2 mV	10 mV	5	4.90 to 5.10
5 mV	20 mV	4	3.92 to 4.08
10 mV	50 mV	5	4.90 to 5.10
20 mV	0.1 V	5	4.90 to 5.10
50 mV	0.2 V	4	3.92 to 4.08
0.1 V	0.5 V	5	4.90 to 5.10
0.2 V	1 V	5	4.90 to 5.10
0.5 V	2 V	4	3.92 to 4.08
1 V	5 V	5	4.90 to 5.10
2 V	10 V	5	4.90 to 5.10
5 V	20 V	4	3.92 to 4.08

c. Move the cable from the CH 1 OR X input connector to the CH 2 OR Y input connector. Set the VERTICAL MODE switch to CH 2.

d. Repeat part b using the Channel 2 controls.

### 8. Check Input Coupling

a. Set both VOLTS/DIV switches to 10 mV.

b. Set the calibration generator to produce a 20-mV signal.

c. Set the bottom of the signal on the center horizontal graticule line using the Channel 2 POSITION control.

d. Set the Channel 2 AC-GND-DC switch to AC.

e. CHECK—Display is centered about the center horizontal graticule line.

f. Move the cable from the CH 2 OR Y input connector to the CH 1 OR X input connector. Set the VERTICAL MODE switch to CH 1.

g. Repeat parts c through e using the Channel 1 controls.

h. Disconnect the test equipment from the instrument.

### 9. Adjust Attenuator Compensation (C12, C11, C5, C4, C62, C61, C55, and C54)

a. Set both AC-GND-DC switches to DC.

b. Connect the high-amplitude square wave output via a 50- $\Omega$  termination, a probe-tip-to-BNC adapter, and the 10X probe to the CH 1 OR X input connector.

c. Set the generator to produce a 1-kHz, 5-division display and compensate the probe using the probe compensation adjustment (see the probe instruction manual).

d. Set the CH 1 VOLTS/DIV switch to 0.1 V.

e. Replace the probe and probe-tip-to-BNC adapter with a 50- $\Omega$  cable.

f. Set the generator to produce a 5-division display.

#### NOTE

*Use Table 5-4 to identify the correct capacitor for each channel adjustment.*

g. ADJUST—The 10X LF Comp capacitor for best front corner.

**Table 5-4**  
**Attenuator Compensation Adjustments**

Adjustment	Channel 1	Channel 2
10X LF Comp	C12	C62
10X Input C	C11	C61
100X LF Comp	C5	C55
100X Input C	C4	C54

h. Replace the 50- $\Omega$  cable and 50- $\Omega$  termination with the probe and probe-tip-to-BNC adapter.

i. Set the generator to produce a 5-division display.

j. ADJUST—The 10X Input C capacitor for best flat top.

k. Repeat parts e through j until no further improvement is noted.

l. Set the CH 1 VOLTS/DIV switch to 1 V.

m. Replace the probe and probe-tip-to-BNC adapter with the 50- $\Omega$  cable and 50- $\Omega$  termination.

n. Set the generator to produce a 5-division display.

o. ADJUST—The 100X LF Comp capacitor for best front corner.

p. Replace the 50- $\Omega$  cable and 50- $\Omega$  termination with the probe and probe-tip-to-BNC adapter.

q. Set the generator to produce a 5-division display.

r. ADJUST—The 100X Input C capacitor for best flat top.

s. Repeat parts m through r until no further improvement is noted.

t. Set the VERTICAL MODE switch to CH 2.

## Adjustment Procedure—2235 Service

- u. Repeat parts b through s for Channel 2.
- v. Disconnect the test equipment from the instrument.

### 10. Check Alternation Operation

a. Set:

VERTICAL MODE	BOTH and ALT
AC-GND-DC (both)	GND
A and B SEC/DIV	50 ms
A&B INT	CH 1

b. Position the Channel 1 and Channel 2 traces about 2 divisions apart using the Channel 1 and Channel 2 POSITION controls.

c. CHECK—Sweeps alternate for all the A SEC/DIV switch settings.

#### NOTE

*At sweep speeds of 2 ms per division or faster, the trace alternations occur too rapidly to be observed.*

### 11. Check Chop Operation

a. Set:

VERTICAL MODE	BOTH and CHOP
A SEC/DIV	1 $\mu$ s
A&B INT	VERT MODE
A SOURCE	EXT

b. Connect the 10X probe to the EXT INPUT connector.

c. Connect the 10X probe tip to TP537.

d. CHECK—Period of one complete square-wave cycle is between 1.6 and 2.6 horizontal divisions.

e. Disconnect the 10X probe from TP537 and the EXT INPUT connector.

f. CHECK—Two traces are visible for all A SEC/DIV switch settings.

### 12. Adjust High-Frequency Compensation (C237), Delay Line Compensation (R240 and R241), and Channel 2 High-Frequency Compensation (C180)

a. Set:

VERTICAL MODE	CH 1
BW LIMIT	Off (button out)
VOLTS/DIV (both)	10 mV
AC-GND-DC (both)	DC
A SEC/DIV	0.05 $\mu$ s
A SOURCE	INT

b. Connect the positive-going fast-rise square wave output via a 50- $\Omega$  cable, a 10X attenuator, and a 50- $\Omega$  termination to the CH 1 OR X input connector.

c. Set the generator to produce a 1-MHz, 5-division display.

d. Set the top of the display to the center horizontal graticule line using the Channel 1 POSITION control.

e. ADJUST—HF Peak Comp (C237) for 2% overshoot (0.1 division) on the displayed signal.

f. ADJUST—DL Comp1 (R240) and DL Comp2 (R241) for best flat top on the front corner.

g. Repeat parts e and f until no further improvement is noted.

h. Set the CH 1 VOLTS/DIV switch to 5 mV.

i. Set the generator to produce a 5-division display.

j. CHECK—Display aberrations are within  $\pm 4\%$  (0.2 division or less).

k. Repeat part j for each of the following CH 1 VOLTS/DIV switch settings: 5 mV through 0.5 V. Adjust the generator output and add or remove the 10X attenuator as necessary to maintain a 5-division display at each VOLTS/DIV switch setting.

l. Move the cable from the CH 1 OR X input connector to the CH 2 OR Y input connector. Set the VERTICAL MODE switch to CH 2.

m. Adjust the generator to produce a 5-division display.

n. Set the top of the display to the center horizontal graticule line using the Channel 2 POSITION control.

o. ADJUST—Ch 2 High-Freq Comp (C180) for 2% overshoot (0.1 division) on the displayed signal.

p. Set the CH 2 VOLTS/DIV switch to 5 mV.

q. Repeat parts i through k for Channel 2.

**13. Adjust 2-mV Peaking Compensation (C76 and C26)**

a. Set both VOLTS/DIV switches to 2 mV.

b. Set the generator to produce a 5-division display.

c. Set the top of the display to the center horizontal graticule line using the Channel 2 POSITION control.

d. ADJUST—Ch 2 2-mV Peak Comp (C76) for 2% overshoot of the displayed signal.

e. Move the cable from the CH 2 OR Y input connector to the CH 1 OR X input connector. Set the VERTICAL MODE switch to CH 1.

f. Repeat parts b through d for Channel 1, adjusting Ch 1 2-mV Peak Comp (C26) in part d.

g. Disconnect the test equipment from the instrument.

**14. Check Trigger View Gain**

a. Set:

VOLTS/DIV (both)	0.1 V
A SEC/DIV	0.2 ms

b. Connect a 0.5-V standard-amplitude signal via a 50-Ω cable to the CH 1 OR X input connector.

c. While holding in the TRIG VIEW button, use the A TRIGGER LEVEL control to vertically center the display.

d. CHECK—Display amplitude is 4 to 6 divisions while holding in the TRIG VIEW button.

e. Move the cable from CH 1 OR X input connector to the CH 2 OR Y input connector. Set the VERTICAL MODE switch to CH 2.

f. Repeat parts c and d.

g. Move the cable from the CH 2 OR Y input connector to the EXT INPUT connector. Set the A SOURCE switch to EXT.

h. Repeat parts c and d.

i. Set the A EXT COUPLING switch to DC.

j. Repeat parts c and d.

k. Set the A EXT COUPLING switch to DC ÷ 10.

l. Set the generator to produce a 5-V signal.

m. Repeat parts c and d.

**15. Check Position Range**

a. Set:

VOLTS/DIV (both)	50 mV
AC-GND-DC (both)	AC
A SOURCE	INT

b. Move the cable from the EXT INPUT connector to the CH 1 OR X input connector.

c. Set the generator to produce a 0.5-V signal.

d. Adjust the CH 2 VOLTS/DIV Variable control to produce a 4.4-division display. Set the CH 2 VOLTS/DIV switch to 10 mV.

e. CHECK—The bottom and top of the trace may be positioned above and below the center horizontal graticule

**Adjustment Procedure—2235 Service**

line by rotating the Channel 2 POSITION control fully clockwise and counterclockwise respectively.

f. Move the cable from the CH 2 OR Y input connector to the CH 1 OR X input connector. Set the VERTICAL MODE switch to CH 1.

g. Repeat parts d and e using the Channel 1 controls.

h. Disconnect the test equipment from the instrument.

**NOTE**

*Install the instrument cabinet for the remaining vertical checks and allow a 20-minute warm-up period before continuing with the Adjustment Procedure. See the "Cabinet" remove and replace instructions located in the "Maintenance" section of the manual.*

**16. Check Bandwidth Limit Operation**

a. Set:

- Vertical POSITION (both) Midrange
- BW LIMIT On (button in)
- VOLTS/DIV Variable (both) CAL detent
- AC-GND-DC (both) DC
- A SEC/DIV 20  $\mu$ s

b. Connect the leveled sine-wave generator output via a 50- $\Omega$  cable and a 50- $\Omega$  termination to the CH 1 OR X input connector.

c. Set the generator to produce a 50-kHz, 6-division display.

d. Increase the generator output frequency until the display amplitude decreases to 4.2 divisions.

e. CHECK—Generator output frequency is between 18 MHz and 22 MHz.

**17. Check Bandwidth**

a. Set:

- BW LIMIT Off (button out)
- VOLTS/DIV (both) 2 mV

b. Set the generator to produce a 50-kHz, 6-division display.

c. CHECK—Display amplitude is 4.2 divisions or greater as the generator output frequency is increased up to the value shown in Table 5-5 for the corresponding VOLTS/DIV switch setting.

**Table 5-5  
Settings for Bandwidth Checks**

VOLTS/DIV Switch Setting	Generator Output Frequency
2 mV	90 MHz
5 mV to 5 V	100 MHz

d. Repeat parts b and c for all indicated CH 1 VOLTS/DIV switch settings, up to the output-voltage upper limit of the sine-wave generator being used.

e. Move the cable from the CH 1 OR X input connector to the CH 2 OR Y input connector. Set the VERTICAL MODE switch to CH 2.

f. Repeat parts b and c for all indicated CH 2 VOLTS/DIV switch settings, up to the output-voltage upper limit of the sine-wave generator being used.

**18. Check Channel Isolation**

a. Set:

- VOLTS/DIV (both) 1 V
- Channel 1 AC-GND-DC GND
- A SEC/DIV 0.1  $\mu$ s

b. Set the generator to produce a 50-MHz, 5-division display.

c. Set the VERTICAL MODE switch to CH 1.

d. CHECK—Display amplitude is 0.05 division or less.

e. Move the cable from the CH 2 OR Y input connector to the CH 1 OR X input connector.

f. Set:

- VERTICAL MODE CH 2
- Channel 1 AC-GND-DC DC
- Channel 2 AC-GND-DC GND

- g. CHECK—Display amplitude is 0.05 division or less.
- h. Disconnect the test equipment from the instrument.

**19. Check Common-Mode Rejection Ratio**

a. Set:

VOLTS/DIV (both)	10 mV
INVERT	On (button in)
Channel 2 AC-GND-DC	DC

b. Connect the leveled sine-wave generator output via a 50-Ω cable, a 50-Ω termination, and a dual-input coupler to the CH 1 OR X and CH 2 OR Y input connectors.

c. Set the generator to produce a 50-MHz, 6-division display.

d. Vertically center the display using the Channel 2 POSITION control. Then set the VERTICAL MODE switch to CH 1 and vertically center the display using the Channel 1 POSITION control.

e. Set the VERTICAL MODE switches to BOTH and ADD.

f. CHECK—Display amplitude is 0.6 division or less.

g. If the check in part f meets the requirement, skip to part p. If it does not, continue with part h.

h. Set the VERTICAL MODE switch to CH 1.

i. Set the generator to produce a 50-kHz, 6-division display.

j. Set the VERTICAL MODE switch to BOTH.

k. Adjust the CH 1 or CH 2 VOLTS/DIV Variable control for minimum display amplitude.

l. Set the VERTICAL MODE switch to CH 1.

m. Set the generator to produce a 50-MHz, 6-division display.

n. Set the VERTICAL MODE switch to BOTH.

o. CHECK—Display amplitude is 0.6 division or less.

p. Disconnect the test equipment from the instrument.

**20. Check Input Gate Current**

a. Set:

VERTICAL MODE	CH 1
VOLTS/DIV (both)	2 mV
VOLTS/DIV Variable (both)	CAL detent
AC-GND-DC (both)	GND

b. Position the trace on the center horizontal graticule line using the Channel 1 POSITION control.

c. CHECK—For 0.1 division or less trace shift while alternating the Channel 1 AC-GND-DC switch between the AC and GND positions.

d. Set the VERTICAL MODE switch to CH 2.

e. Repeat parts b and c using the Channel 2 controls.

**NOTE**

*To continue with the Adjustment Procedure, remove the instrument cabinet and allow a 20-minute time period to elapse before continuing with the Adjustment Procedure. See the "Cabinet" removal instructions located in the "Maintenance" section of the manual.*

# HORIZONTAL

**Equipment Required (see Table 4-1):**

Calibration Generator (Item 1)	50-Ω BNC Termination (Item 5)
Leveled Sine-Wave Generator (Item 2)	Test Oscilloscope (Item 11)
Time-Mark Generator (Item 3)	Screwdriver (Item 13)
50-Ω Cable (Item 4)	Low-Capacitance Alignment Tool (Item 14)

See **ADJUSTMENT LOCATIONS 1** and **ADJUSTMENT LOCATIONS 3**  
 at the back of the manual for test points and adjustments locations.

## INITIAL CONTROL SETTINGS

### Vertical

POSITION (both)	Midrange
VERTICAL MODE	CH 1
BW LIMIT	Off (button out)
CH 1 VOLTS/DIV	0.5 V
CH 1 VOLTS/DIV Variable	CAL detent
Channel 1 AC-GND-DC	DC

### Horizontal

POSITION	Midrange
HORIZONTAL MODE	A
A and B SEC/DIV	0.1 ms
SEC/DIV Variable	CAL detent
X10 Magnifier	Off (knob in)
B DELAY TIME POSITION	Fully counterclockwise

### B TRIGGER

SLOPE	OUT
LEVEL	Fully clockwise

### A TRIGGER

VAR HOLDOFF	NORM
Mode	P-P AUTO
SLOPE	OUT
LEVEL	Midrange
A&B INT	VERT MODE
A SOURCE	INT

## PROCEDURE STEPS

### 1. Adjust Horizontal Amplifier Gain (R740 and R730)

a. Connect 0.1-ms time markers from the time-mark generator via a 50-Ω cable and a 50-Ω termination to the CH 1 OR X input connector.

b. Align the first time marker with the first (extreme left) vertical graticule line using the Horizontal POSITION control.

c. ADJUST—A Sweep Gain (R740) for 1 time marker per division over the center 8 divisions.

#### NOTE

*When making timing measurements, use as a reference the tips of the time markers positioned at the center horizontal graticule line.*

d. Set the HORIZONTAL MODE switch to B.

e. ADJUST—B Sweep Gain (R730) for 1 time marker per division.

**2. Adjust X10 Horizontal Amplifier Gain (R754)**

a. Set:

HORIZONTAL MODE	A
X10 Magnifier	On (knob out)

b. Select 10- $\mu$ s time markers from the time-mark generator.

c. Align the nearest time marker to the first vertical graticule line with the first graticule line.

d. ADJUST—X10 Gain (R754) for 1 time marker per division.

**3. Adjust Magnifier Registration (R749)**

a. Set the A SEC/DIV switch to 0.2 ms.

b. Select 1-ms time markers from the time-mark generator.

c. Position the middle time marker to the center vertical graticule line using the Horizontal POSITION control.

d. Set the X10 Magnifier to Off (knob in).

e. ADJUST—Mag Regis (R749) to position the middle time marker to the center vertical graticule line.

f. Set the X10 Magnifier to On (knob out) and CHECK for no horizontal shift in the time marker.

g. Repeat parts c through f until no further improvement is noted.

**4. Check Sweep Length**

a. Set:

Channel 1 AC-GND-DC	GND
X10 Magnifier	Off (knob in)

b. Position the start of the sweep at the first vertical graticule line using the Horizontal POSITION control.

c. CHECK—End of the sweep is to the right of the 11th vertical graticule line.

**5. Check Position Range**

a. Set:

Channel 1 AC-GND-DC	DC
A SEC/DIV	10 $\mu$ s

b. Select 10- $\mu$ s time markers from the time-mark generator.

c. CHECK—Start of the sweep can be positioned to the right of the center vertical graticule line by rotating the Horizontal POSITION control fully clockwise.

d. CHECK—The 11th time marker can be positioned to the left of the center vertical graticule line by rotating the Horizontal POSITION control fully counterclockwise.

e. Select 50- $\mu$ s time markers from the time-mark generator.

f. Align the 3rd time marker with the center vertical graticule line using the Horizontal POSITION control.

g. Set the X10 Magnifier to On (knob out).

h. CHECK—Magnified time marker can be positioned to the left of the center vertical graticule line by rotating the Horizontal POSITION control fully counterclockwise.

i. CHECK—Start of the sweep can be positioned to the right of the center vertical graticule line by rotating the Horizontal POSITION control fully clockwise.

**6. Check Variable Range**

a. Set:

Horizontal POSITION	Midrange
A SEC/DIV	0.2 ms
SEC/DIV Variable	Fully counterclockwise
X10 Magnifier	Off (knob in)

b. Select 0.5-ms time markers from the time-mark generator.

c. CHECK—Time markers are 1 division or less apart.

### 7. Adjust Delay Dial Timing (R646 and R652)

a. Set:

HORIZONTAL MODE	ALT
A SEC/DIV	0.1 ms
B SEC/DIV	1 $\mu$ S
SEC/DIV Variable	CAL detent
B DELAY TIME POSITION	1.00

b. Select 0.1-ms time markers from the time-mark generator.

c. Adjust the A/B SWP SEP control to separate the A and B Sweeps.

d. ADJUST—Delay Start (R646) so that the 2nd A-Sweep time marker is intensified and the B-Sweep time marker's rising edge starts at the beginning of the B Sweep.

e. Set the B DELAY TIME POSITION dial to 9.00.

f. ADJUST—Delay End (R652) so that the 10th A-Sweep time marker is intensified and the B-Sweep time marker's rising edge starts at the beginning of the B Sweep.

g. Set the B DELAY TIME POSITION dial to 1.00.

h. Repeat parts d through g until no further improvement is noted.

### 8. Adjust High-Speed Timing (C703 and C713)

a. Set:

HORIZONTAL MODE	A
A SEC/DIV	0.1 $\mu$ S

b. Select 0.1- $\mu$ S time markers from the time-mark generator.

c. ADJUST—A High Speed Timing (C703) for 1 time marker per division over the center 8 divisions.

d. Set:

HORIZONTAL MODE	B
A SEC/DIV	0.2 $\mu$ S
B SEC/DIV	0.1 $\mu$ S

e. ADJUST—B High Speed Timing (C713) for 1 time marker per division over the center 8 divisions.

### 9. Adjust 5-ns Timing and Linearity (C775 and C785)

a. Set:

CH 1 VOLTS/DIV	0.2 V
HORIZONTAL MODE	A
A SEC/DIV	0.05 $\mu$ S
X10 Magnifier	On (knob out)

b. Select 10-ns time markers from the time-mark generator.

c. Align the time markers with the vertical graticule lines using the Horizontal POSITION control.

d. ADJUST—5-ns Timing (C775 and C785 alternately) for one time marker every 2 divisions over the center 8 divisions of the magnified sweep.

e. CHECK—Time markers between the 2nd and 4th vertical graticule lines should be aligned within 0.05 division. If not, a slight compromise between timing and linearity should be made by readjusting the 5-ns Timing capacitors (C775 and C785).

### 10. Check Timing Accuracy and Linearity

a. Set:

CH 1 VOLTS/DIV	0.5 V
X10 Magnifier	Off (knob in)
A TRIGGER Mode	NORM

b. Select 50-ns time markers from the time-marker generator.

c. Adjust the A TRIGGER LEVEL control for a stable, triggered display.

d. Use the Horizontal POSITION control to align the second time marker with the second vertical graticule line.

e. CHECK—Timing accuracy is within 2% (0.16 division at the 10th vertical graticule line), and linearity is within 5% (0.1 division over any 2 of the center 8 divisions).

**Table 5-6**  
**Settings for Timing Accuracy Checks**

SEC/DIV Switch Setting	Time-Mark Generator Setting	
	Normal	X10 Magnified
0.05 $\mu$ s	50 ns	10 ns
0.1 $\mu$ s	0.1 $\mu$ s	10 ns
0.2 $\mu$ s	0.2 $\mu$ s	20 ns
0.5 $\mu$ s	0.5 $\mu$ s	50 ns
1 $\mu$ s	1 $\mu$ s	0.1 $\mu$ s
2 $\mu$ s	2 $\mu$ s	0.2 $\mu$ s
5 $\mu$ s	5 $\mu$ s	0.5 $\mu$ s
10 $\mu$ s	10 $\mu$ s	1 $\mu$ s
20 $\mu$ s	20 $\mu$ s	2 $\mu$ s
50 $\mu$ s	50 $\mu$ s	5 $\mu$ s
0.1 ms	0.1 ms	10 $\mu$ s
0.2 ms	0.2 ms	20 $\mu$ s
0.5 ms	0.5 ms	50 $\mu$ s
1 ms	1 ms	0.1 ms
2 ms	2 ms	0.2 ms
5 ms	5 ms	0.5 ms
10 ms	10 ms	1 ms
20 ms	20 ms	2 ms
50 ms	50 ms	5 ms
A Sweep Only		
0.1 s	0.1 s	10 ms
0.2 s	0.2 s	20 ms
0.5 s	0.5 s	50 ms

**NOTE**

*For checking the timing accuracy of the A SEC/DIV switch settings from 50 ms to 0.5 s, watch the time marker tips only at the 2nd and 10th vertical graticule lines while adjusting the Horizontal POSITION control.*

f. Repeat parts c through e for the remaining A SEC/DIV and time-mark generator setting combinations shown in Table 5-6 under the "Normal" column.

g. Set the X10 Magnifier to On (knob out).

h. Select 50-ms time markers from the time-mark generator when checking the A Sweep and 5-ms time markers when checking the B Sweep.

i. Use the Horizontal POSITION control to align the first time marker that is 25 ns beyond the start of the sweep with the second vertical graticule line.

j. CHECK—Timing accuracy is within 3% (0.24 division at the 10th vertical graticule line), and linearity is within 5% (0.1 division over any 2 of the center 8 divisions). Exclude any portion of the sweep past the 100th magnified division.

k. Repeat parts i and j for the remaining A SEC/DIV and time-mark generator setting combinations shown in Table 5-6 under the "X10 Magnified" column.

l. Set:

HORIZONTAL MODE	B
A SEC/DIV	0.1 $\mu$ s
B SEC/DIV	0.05 $\mu$ s
X10 Magnifier	Off (knob in)

m. Repeat parts b through k for the B Sweep. Keep the A SEC/DIV switch one setting slower than the B SEC/DIV switch.

**11. Check Delay Time Dial Range and Accuracy**

a. Set:

Channel 1 AC-GND-DC	GND
HORIZONTAL MODE	ALT
A and B SEC/DIV	0.2 ms
X10 Magnifier	Off (knob in)
B DELAY TIME POSITION	Fully counterclockwise
A TRIGGER Mode	P-P AUTO

b. Align the start of the A Sweep with the 1st vertical graticule line using the Horizontal POSITION control.

c. CHECK—Intensified portion of the trace starts within 0.5 division of the start of the sweep.

d. Rotate the B DELAY TIME POSITION control fully clockwise.

e. CHECK—Intensified portion of the trace is past the 11th vertical graticule line.

f. Set:

A and B SEC/DIV	0.5 $\mu$ s
B DELAY TIME POSITION	Fully counterclockwise

## Adjustment Procedure—2235 Service

g. Align the start of the A Sweep with the 1st vertical graticule line using the Horizontal POSITION control.

h. CHECK—Intensified portion of the trace starts within 1.1 divisions of the start of the sweep.

i. Repeat parts d and e.

j. Set:

Channel 1 AC-GND-DC	DC
HORIZONTAL MODE	B
A SEC/DIV	0.5 $\mu$ S
B SEC/DIV	0.05 $\mu$ S
B DELAY TIME POSITION	1.00

k. Select 0.5- $\mu$ S time markers from the time-mark generator.

l. Adjust the Horizontal POSITION control so that the top of the first fully displayed time marker is aligned with the center vertical graticule line.

m. Without changing the Horizontal POSITION control setting, set the B DELAY TIME POSITION dial to 9.00. Slightly readjust the B DELAY TIME POSITION dial to align the top of the time marker with the center vertical graticule line.

n. CHECK—The B DELAY TIME POSITION dial setting is between 8.905 and 9.095.

o. Repeat parts l through n for the remaining A and B SEC/DIV and time-mark generator setting combinations shown in Table 5-7.

**Table 5-7**  
**Settings for Delay Time Accuracy Checks**

A SEC/DIV Switch Setting	B SEC/DIV Switch Setting	Time-Mark Generator Setting
0.5 $\mu$ S	0.05 $\mu$ S	0.5 $\mu$ S
5 $\mu$ S	0.5 $\mu$ S	5 $\mu$ S
0.5 ms	50 $\mu$ S	0.5 ms
5 ms	0.5 ms	5 ms
0.5 s	50 ms	0.5 s

p. Set:

A SEC/DIV	5 $\mu$ S
B SEC/DIV	0.5 $\mu$ S
B DELAY TIME POSITION	1.00

q. Select 5- $\mu$ S time markers from the time-mark generator.

r. Adjust the Horizontal POSITION control so that the rising edge of the displayed time marker is aligned with the center vertical graticule line.

s. Without changing the Horizontal POSITION control setting, turn the B DELAY TIME POSITION dial clockwise to position the next time marker leading edge to the center vertical graticule line.

t. CHECK—The B DELAY TIME POSITION dial setting is 0.975 to 1.025 greater than the previous setting.

u. Set the B DELAY TIME POSITION dial to the exact integer setting.

v. Repeat parts r through u for each successive time marker up to the marker corresponding to the B DELAY TIME POSITION dial setting of 10.00.

## 12. Check Delay Jitter

a. Set:

A SEC/DIV	0.5 ms
B SEC/DIV	0.5 $\mu$ S
B DELAY TIME POSITION	10.00

b. Select 50- $\mu$ S time markers from the time-mark generator.

c. Rotate the B DELAY TIME POSITION dial counter-clockwise to position a time marker within the graticule area for each major dial division and CHECK that the jitter on the leading edge does not exceed 0.5 division. Disregard slow drift.

d. Disconnect the test equipment from the instrument.

**13. Check Sweep Separation**

a. Set:

HORIZONTAL MODE	ALT
A and B SEC/DIV	0.5 ms

b. Use the Channel 1 POSITION control to set the A Sweep at the center horizontal graticule line.

c. CHECK—The B Sweep can be positioned more than 3.5 divisions above and below the A Sweep when the A/B SWP SEP control is rotated fully clockwise and counter-clockwise respectively.

**14. Adjust X Gain (R760)**

a. Set:

CH 1 VOLTS/DIV	10 mV
A SEC/DIV	X-Y

b. Connect a 50-mV standard-amplitude signal via a 50-Ω cable to the CH 1 or X input connector.

c. ADJUST—X Gain (R760) for exactly 5-divisions of horizontal deflection.

d. Disconnect the test equipment from the instrument.

**15. Check X Bandwidth**

a. Connect the leveled sine-wave generator output via a 50-Ω cable and a 50-Ω termination to the CH 1 OR X input connector.

b. Set the generator to produce a 5-division horizontal display at an output frequency of 50 kHz.

c. Increase the generator output frequency to 3 MHz.

d. CHECK—Display is at least 3.5 horizontal divisions.

e. Disconnect the test equipment from the instrument.

**16. Check A-Sweep Holdoff**

a. Set:

HORIZONTAL MODE	A
A SEC/DIV	1 ms
VAR HOLDOFF	NORM

b. Connect the test oscilloscope and its 10X probe tip to the front end of R707 (toward the front panel) which is located on the Timing circuit board.

c. CHECK—The A-Sweep holdoff is greater than 3 ms but less than 7 ms.

d. Rotate the VAR HOLDOFF control to the maximum clockwise position (MAX).

e. CHECK—The A-Sweep holdoff has increased by a factor of 10 or more.

f. Disconnect the test oscilloscope 10X probe from R707.

# TRIGGER

**Equipment Required (see Table 4-1):**

Leveled Sine-Wave Generator (Item 2)	10X Attenuator (Item 7)
50-Ω BNC Cable (Item 4)	Digital Voltmeter (Item 12)
50-Ω BNC Termination (Item 5)	Screwdriver (Item 13)

See **ADJUSTMENT LOCATIONS 1**

at the back of this manual for test points and adjustment locations.

## INITIAL CONTROL SETTINGS

### Vertical (Both Channels)

POSITION	Midrange
VERTICAL MODE	BOTH-ALT
BW LIMIT	Off (button out)
VOLTS/DIV	0.5 V
VOLTS/DIV Variable	CAL detent
INVERT	Off (button out)
AC-GND-DC	GND

### Horizontal

POSITION	Midrange
HORIZONTAL MODE	A
A and B SEC/DIV	1 ms
SEC/DIV Variable	CAL detent
X10 Magnifier	Off (knob in)
B DELAY TIME POSITION	Fully counterclockwise

### B TRIGGER

SLOPE	OUT
LEVEL	Midrange

### A TRIGGER

VAR HOLDOFF	NORM
Mode	P-P AUTO
SLOPE	OUT
LEVEL	Midrange
A&B INT	CH 2
A SOURCE	INT
A EXT COUPLING	DC

## PROCEDURE STEPS

### 1. Adjust Trigger Offset (R309)

a. Set the Channel 1 trace and the Channel 2 trace to the center horizontal graticule line using the Channel 1 and Channel 2 POSITION controls.

b. Connect the digital voltmeter low lead to chassis ground and the high (volts) lead to W4000-1 (Alt Sweep Logic circuit board connector to the Main circuit board).

c. CHECK—The offset voltage reading is less than 80 mV. Note the reading for use in part e.

d. Set the A&B INT switch to CH 1.

e. ADJUST—Trigger Offset (R309) so that the voltage reading is the same as that obtained in part c.

f. Set the A&B INT switch to CH 2.

g. Repeat parts c through f until there is 1 mV or less difference in the voltmeter readings between the CH 1 and CH 2 positions of the A&B INT switch.

### 2. Adjust Trigger Sensitivity (R479)

a. Set:

VERTICAL MODE	CH 1
CH 1 VOLTS/DIV	0.1 V
AC-GND-DC (both)	AC
A SEC/DIV	10 μs

b. Connect the leveled sine-wave generator output via a 50-Ω cable and a 50-Ω termination to the CH 1 OR X input connector.

c. Set the generator to produce a 50-kHz, 2.2-division display.

d. Set the CH 1 VOLTS/DIV switch to 1 V.

e. ADJUST—Trigger Sensitivity (R479) while rotating the A TRIGGER LEVEL control slowly so that the A Trigger is just able to be maintained.

### 3. Adjust Slope Balance (R471)

a. Set the CH 1 VOLTS/DIV switch to 50 mV.

b. Set the generator to produce a 4-division display.

c. ADJUST—Slope Bal (R471) for a downward vertical shift of 0.22-division at the start of the sweep when changing the A TRIGGER SLOPE switch between the OUT and IN positions.

### 4. Adjust P-P Auto Trigger Centering (R434 and R435)

a. Set:

A TRIGGER SLOPE           OUT  
A TRIGGER LEVEL       Fully clockwise

b. Set the generator to produce a 50-kHz, 5-division display.

c. Set the CH 1 VOLTS/DIV switch to 0.5 V.

d. ADJUST—(+ ) Auto (R434) so that the vertical display just solidly triggers on the positive peak of the signal.

e. Set:

A TRIGGER SLOPE           IN  
A TRIGGER LEVEL       Fully counterclockwise

f. ADJUST—(– ) Auto (R435) so that the display just solidly triggers on the negative peak of the signal.

### 5. Check Internal Triggering

a. Set:

CH 1 VOLTS/DIV           5 mV  
CH 2 VOLTS/DIV           50 mV  
A and B SEC/DIV         0.2 μs  
A&B INT                   CH 1

b. Set the generator to produce a 10-MHz, 3-division display.

c. Set the CH 1 VOLTS/DIV switch to 50 mV.

d. CHECK—Stable display can be obtained by adjusting the A TRIGGER LEVEL control for each switch combination given in Table 5-8.

**Table 5-8**  
**Switch Combinations for A Triggering Checks**

A TRIGGER Mode	A TRIGGER SLOPE
NORM	OUT
NORM	IN
P-P AUTO	IN
P-P AUTO	OUT

e. Set the HORIZONTAL MODE switch to B.

f. CHECK—Stable display can be obtained by adjusting the B TRIGGER LEVEL control in a position other than the B RUNS AFTER DLY position for both the OUT and IN positions of the B TRIGGER SLOPE switch.

g. Set:

VERTICAL MODE           CH 2  
HORIZONTAL MODE        A  
A&B INT                   CH 2

h. Move the cable from the CH 1 OR X input connector to the CH 2 OR Y input connector.

i. Repeat parts d through f.

## Adjustment Procedure—2235 Service

j. Set:

HORIZONTAL MODE	A
A SEC/DIV	0.1 $\mu$ s
X10 Magnifier	On (knob out)

k. Set the generator to produce a 60-MHz, 1.0-division display.

l. Repeat parts d through f.

m. Set:

VERTICAL MODE	CH 1
HORIZONTAL MODE	A
A&B INT	VERT MODE

n. Move the cable from the CH 2 OR Y input connector to the CH 1 OR X input connector.

o. Repeat parts d through f.

p. Set:

HORIZONTAL MODE	A
A SEC/DIV	0.05 $\mu$ s

q. Set the generator to produce a 100-MHz, 1.5-division display.

r. Repeat parts d through f.

s. Set:

VERTICAL MODE	CH 2
HORIZONTAL MODE	A

t. Move the cable from the CH 1 OR X input connector to the CH 2 OR Y input connector.

u. Repeat parts d through f.

v. Disconnect the test equipment from the instrument.

## 6. Check External Triggering

a. Set:

VERTICAL MODE	CH 1
HORIZONTAL MODE	A
X10 Magnifier	Off (knob in)
A SOURCE	EXT

b. Connect a 35-mV, 10-MHz leveled sine-wave signal via a 50- $\Omega$  cable and a 50- $\Omega$  termination to the EXT INPUT connector.

c. Push in and hold the TRIG VIEW button.

d. CHECK—Stable display can be obtained by adjusting the A TRIGGER LEVEL control for each switch combination given in Table 5-8. Then release the TRIG VIEW button.

e. Set the generator output voltage to 120 mV and the frequency to 60 MHz. Set the X10 Magnifier to On (knob out).

f. Repeat parts c and d.

g. Set the generator output voltage to 200 mV and the frequency to 100 MHz.

h. Repeat parts c and d.

i. Disconnect the test equipment from the instrument.

## 7. Check External Trigger Ranges

a. Set:

CH 1 VOLTS/DIV	0.5 V
A SEC/DIV	20 $\mu$ s
X10 Magnifier	Off (knob in)
A TRIGGER Mode	NORM

b. Connect the leveled sine-wave generator output via a 50- $\Omega$  cable, a 50- $\Omega$  termination, and a dual-input coupler to both the CH 1 OR X and EXT INPUT connectors.

c. Set the generator to produce a 50-kHz, 6.4-division display.

d. CHECK—Display is triggered along the entire positive slope of the waveform as the A TRIGGER LEVEL control is rotated.

e. CHECK—Display is not triggered (no trace) at either extreme of rotation.

f. Set the A TRIGGER SLOPE button to IN.

g. CHECK—Display is triggered along the entire negative slope of the waveform as the A TRIGGER LEVEL control is rotated.

h. CHECK—Display is not triggered (no trace) at either extreme of rotation.

### 8. Check Single Sweep Operation

a. Adjust the A TRIGGER LEVEL control to obtain a stable display.

b. Set:

Channel 1 AC-GND-DC	GND
A SOURCE	INT

c. Press in the SGL SWP button. The READY LED should illuminate and remain on.

d. Set the Channel 1 AC-GND-DC switch to DC.

e. CHECK—READY LED goes out and a single sweep occurs.

#### NOTE

*The A INTENSITY control may require adjustment to observe the single-sweep trace.*

f. Press in the SGL SWP button several times.

g. CHECK—Single-sweep trace occurs, and the READY LED illuminates briefly every time the SGL SWP button is pressed in and released.

h. Disconnect the test equipment from the instrument.

## EXTERNAL Z-AXIS AND PROBE ADJUST

**Equipment Required (see Table 4-1):**

Leveled Sine-Wave Generator (Item 2)	BNC T-Connector (Item 8)
Two 50-Ω BNC Cables (Item 4)	10X Probe (provided with instrument)
50-Ω BNC Termination (Item 5)	

### INITIAL CONTROL SETTINGS

**Vertical**

Channel 1 POSITION	Midrange
VERTICAL MODE	CH 1
BW LIMIT	Off (button out)
CH 1 VOLTS/DIV	1 V
CH 1 VOLTS/DIV Variable	CAL detent
Channel 1 AC-GND-DC	DC

**Horizontal**

POSITION	Midrange
HORIZONTAL MODE	A
A SEC/DIV	20 μs
SEC/DIV Variable	CAL detent
X10 Magnifier	Off (knob in)

**A TRIGGER**

VAR HOLDOFF	NORM
Mode	P-P AUTO
SLOPE	OUT
LEVEL	Midrange
A&B INT	VERT MODE
A SOURCE	INT

### PROCEDURE STEPS

**1. Check External Z-Axis Operation**

a. Connect the leveled sine-wave generator output via a 50-Ω cable and a T-connector to the CH 1 OR X input con-

connector. Then connect a 50-Ω cable and a 50-Ω termination from the T-connector to the EXT Z AXIS INPUT connector on the rear panel.

b. Set the generator to produce a 5-V, 50-kHz signal.

c. CHECK—For noticeable intensity modulation. The positive part of the sine wave should be of lower intensity than the negative part.

d. Disconnect the test equipment from the instrument.

**2. Check Probe Adjust Operation**

a. Set:

CH 1 VOLTS/DIV	10 mV
A SEC/DIV	0.5 ms

b. Connect the 10X Probe to the CH 1 OR X input connector and insert the probe tip into the PROBE ADJUST jack on the instrument front panel. If necessary, adjust the probe compensation for a flat-topped square-wave display.

c. CHECK—Display amplitude is 4.75 to 5.25 divisions.

d. Disconnect the probe from the instrument.

# MAINTENANCE

This section of the manual contains information for conducting preventive maintenance, troubleshooting, and corrective maintenance on the 2235 Oscilloscope.

## STATIC-SENSITIVE COMPONENTS

The following precautions are applicable when performing any maintenance involving internal access to the instrument.

**CAUTION**

*Static discharge can damage any semiconductor component in this instrument.*

This instrument contains electrical components that are susceptible to damage from static discharge. Table 6-1 lists the relative susceptibility of various classes of semiconductors. Static voltages of 1 kV to 30 kV are common in unprotected environments.

When performing maintenance observe the following precautions to avoid component damage:

1. Minimize handling of static-sensitive components.
2. Transport and store static-sensitive components or assemblies in their original containers or on a metal rail. Label any package that contains static-sensitive components or assemblies.
3. Discharge the static voltage from your body by wearing a grounded antistatic wrist strap while handling these components. Servicing static-sensitive components or assemblies should be performed only at a static-free work station by qualified service personnel.
4. Nothing capable of generating or holding a static charge should be allowed on the work station surface.
5. Keep the component leads shorted together whenever possible.
6. Pick up components by their bodies, never by their leads.

**Table 6-1  
Susceptibility  
to Static Discharge Damage**

Semiconductor Classes	Relative Susceptibility Levels <sup>a</sup>
MOS or CMOS microcircuits or discretes, or linear microcircuits with MOS inputs. (Most Sensitive)	1
ECL	2
Schottky signal diodes	3
Schottky TTL	4
High-frequency bipolar transistors	5
JFETs	6
Linear microcircuits	7
Low-power Schottky TTL	8
TTL (Least Sensitive)	9

<sup>a</sup>Voltage equivalent for levels: (Voltage discharged from a 100 pF capacitor through a resistance of 100 Ω.)

1 = 100 to 500 V    4 = 500 V    7 = 400 to 1000 V(est.)  
 2 = 200 to 500 V    5 = 400 to 600 V    8 = 900 V  
 3 = 250 V    6 = 600 to 800 V    9 = 1200 V

7. Do not slide the components over any surface.
8. Avoid handling components in areas that have a floor or work-surface covering capable of generating a static charge.
9. Use a soldering iron that is connected to earth ground.
10. Use only approved antistatic, vacuum-type desoldering tools for component removal.

# PREVENTIVE MAINTENANCE

## INTRODUCTION

Preventive maintenance consists of cleaning, visual inspection, lubrication, and checking instrument performance. When accomplished regularly, it may prevent instrument malfunction and enhance instrument reliability. The severity of the environment in which the instrument is used determines the required frequency of maintenance. An appropriate time to accomplish preventive maintenance is just before instrument adjustment.

## GENERAL CARE

The cabinet minimizes accumulation of dust inside the instrument and should normally be in place when operating the oscilloscope. The optional front-panel cover provides both dust and damage protection for the front panel and crt face, and it should be in place whenever the instrument is stored or is being transported.

## INSPECTION AND CLEANING

The instrument should be visually inspected and cleaned as often as operating conditions require. Accumulation of dirt in the instrument can cause overheating and component breakdown. Dirt on components acts as an insulating blanket, preventing efficient heat dissipation. It also provides an electrical conduction path that could result in instrument failure, especially under high-humidity conditions.

### CAUTION

*Avoid the use of chemical cleaning agents which might damage the plastics used in this instrument. Use a nonresidue-type cleaner, preferably isopropyl alcohol, denatured ethyl alcohol, or a solution of 5% mild detergent with 95% water. Before using any other type of cleaner, consult your Tektronix Service Center or representative.*

## Exterior

**INSPECTION.** Inspect the external portion of the instrument for damage, wear, and missing parts; use Table 6-2 as a guide. Instruments that appear to have been dropped or otherwise abused should be checked thoroughly to verify correct operation and performance. Deficiencies found that could cause personal injury or could lead to further damage to the instrument should be repaired immediately.

### CAUTION

*To prevent getting moisture inside the instrument during external cleaning, use only enough liquid to dampen the cloth or applicator.*

**CLEANING.** Loose dust on the outside of the instrument can be removed with a soft cloth or small soft-bristle brush. The brush is particularly useful for dislodging dirt on and around the controls and connectors. Dirt that remains can be removed with a soft cloth dampened in a mild detergent-and-water solution. Do not use abrasive cleaners. Clean the light filter and the crt face with a soft lint-free cloth dampened with either denatured alcohol or a mild detergent-and-water solution.

## Interior

To gain access to internal portions of the instrument for inspection and cleaning, refer to the "Removal and Replacement Instructions" in the "Corrective Maintenance" part of this section.

**INSPECTION.** Inspect the internal portions of the instrument for damage and wear, using Table 6-3 as a guide. Deficiencies found should be repaired immediately. The corrective procedure for most visible defects is obvious; however, particular care must be taken if heat-damaged components are found. Overheating usually indicates other trouble in the instrument; therefore, it is important that the cause of overheating be corrected to prevent recurrence of the damage.

If you didn't obtain this scanned manual from <http://www.aa4df.com>, you have been sold or given stolen property. If it was a free download, please understand that the wannabe good Samaritan that gave it to you did not invest the time and material to create it, has no authorization to distribute it, and is stealing from the poor, not from the rich.

**Table 6-2**  
**External Inspection Checklist**

Item	Inspect For	Repair Action
Cabinet and Front Panel	Cracks, scratches, deformations, and damaged hardware or gaskets.	Touch up paint and replace defective parts.
Front-panel Controls	Missing, damaged, or loose knobs, buttons, and controls.	Repair or replace missing or defective items.
Connectors	Broken shells, cracked insulation, and deformed contacts. Dirt in connectors.	Replace defective parts. Clean or wash out dirt.
Carrying Handle	Correct operation.	Replace defective parts.
Accessories	Missing items or parts of items, bent pins, broken or frayed cables, and damaged connectors.	Replace damaged or missing items, frayed cables, and defective parts.

**Table 6-3**  
**Internal Inspection Checklist**

Item	Inspect For	Repair Action
Circuit Boards	Loose, broken, or corroded solder connections. Burned circuit boards. Burned, broken, or cracked circuit-run plating.	Clean solder corrosion with an eraser and flush with isopropyl alcohol. Resolder defective connections. Determine cause of burned items and repair. Repair defective circuit runs.
Resistors	Burned, cracked, broken, or blistered.	Replace defective resistors. Check for cause of burned component and repair as necessary.
Solder Connections	Cold solder or rosin joints.	Resolder joint and clean with isopropyl alcohol.
Capacitors	Damaged or leaking cases. Corroded solder on leads or terminals.	Replace defective capacitors. Clean solder connections and flush with isopropyl alcohol.
Wiring and Cables	Loose plugs or connectors. Burned, broken, or frayed wiring.	Firmly seat connectors. Repair or replace defective wires or cables.
Chassis	Dents, deformations, and damaged hardware.	Straighten, repair, or replace defective hardware.

If any electrical component is replaced, conduct a Performance Check of the affected circuit and of other closely related circuit (see Section 4). If repair or replacement work is done on any of the power supplies, conduct a complete Performance Check and, if so indicated, an instrument readjustment (see Section 5).



*To prevent damage from electrical arcing, ensure that circuit boards and components are dry before applying power to the instrument.*

**CLEANING.** To clean the interior, blow off dust with dry, low-pressure air (approximately 9 psi). Remove any remaining dust with a soft brush or a cloth dampened with a solution of mild detergent and water. A cotton-tipped applicator is useful for cleaning in narrow spaces and on circuit boards.

If these methods do not remove all the dust or dirt, the instrument may be spray washed using a solution of 5% mild detergent and 95% water as follows:

1. Gain access to the parts to be cleaned (see "Removal and Replacement Instructions").

## Maintenance—2235 Service

2. Spray wash dirty parts with the detergent-and-water solution; then use clean water to thoroughly rinse them.

3. Dry all parts with low-pressure air.

**SWITCH CONTACTS.** The VOLTS/DIV and THE SEC/DIV Switches are mounted circuit-boards within the instrument. Care must be exercised to preserve the high-frequency characteristics of these switches. Switch maintenance is seldom necessary, but if it is required, observe the following precautions.

1. The VOLTS/DIV switches contain cam-actuated contacts.



*Most spray-type circuit coolants contain Freon 12 as a propellant. Because many Freons adversely affect switch contacts, do not use a spray-type coolants.*

*The only recommended circuit coolants for the volts-division attenuators are dry ice (CO<sub>2</sub>) and isopropyl alcohol.*

a. Use only isopropyl alcohol as a cleaning solution, especially in the area of the vertical Attenuator circuit board. Carbon-based solvents will damage the board material.

b. Apply the alcohol with a small, camel-hair brush. Do not use cotton-tipped applicators when cleaning contacts.

2. The SEC/DIV switch is comprised of rotary-activated contacts.



*Use only hot deionized or distilled water, 55°C (131°F), to clean the timing switch in this instrument. Tap water contains impurities which are left as residuals after evaporation.*

a. Spray hot water into the slots at the top of each switch housing while rotating the switch control knob.

Spray only for approximately five seconds, using an atomizing spray device.

b. Dry both the switch and the circuit board on which it is mounted, using dry low-pressure air.

c. Bake the switch and the circuit board in an oven at 75°C (167°F) for 15 minutes to eliminate all moisture.

d. Spray a very small amount (only about a 1/2-second squirt) of a recommended lubricant, such as No Noise, into the slots at the top of the switch housing.

e. Rotate the switch control knob about 180° and again spray a very small amount of lubricant into each slot.

## LUBRICATION

Most of the potentiometers used in this instrument are permanently sealed and generally do not require periodic lubrication. All switches, both rotary- and lever-type, are installed with proper lubrication applied where necessary and will rarely require any additional lubrication. Therefore, a regular periodic lubrication program for the instrument is not recommended.

## SEMICONDUCTOR CHECKS

Periodic checks of the transistors and other semiconductors in the oscilloscope are not recommended. The best check of semi-conductor performance is actual operation in the instrument.

## PERIODIC READJUSTMENT

To ensure accurate measurements, check the performance of this instrument after every 2000 hours of operation, or if used infrequently, once each year. In addition, replacement of components may necessitate readjustment of the affected circuits.

Complete Performance Check and Adjustment instructions are given in Sections 4 and 5. The Performance Check Procedure can also be helpful in localizing certain trouble in the instrument. In some cases, minor problems may be revealed or corrected by readjustment. If only a partial adjustment is performed, see the interaction chart, Table 5-1, for possible adjustment interactions with other circuits.

# TROUBLESHOOTING

## INTRODUCTION

Preventive maintenance performed on a regular basis should reveal most potential problems before an instrument malfunctions. However, should troubleshooting be required, the following information is provided to facilitate location of a fault. In addition, the material presented in the "Theory of Operation" and the "Diagrams" sections of this manual may be helpful while troubleshooting.

## TROUBLESHOOTING AIDS

### Schematic Diagrams

Complete schematic diagrams are located on tabbed foldout pages in the "Diagrams" section. The portions of circuitry that are mounted on each circuit board are enclosed within heavy black lines. Also within the black lines, near either the top or the bottom edge, are the assembly number and name of the circuit board.

Component numbers and electrical values of components in this instrument are shown on the schematic diagrams. Refer to the first page of the "Diagrams" section for definitions of the reference designators and symbols used to identify components.

### Circuit Board Illustrations

Circuit board illustrations (showing the physical location of each component) are provided for use in conjunction with each schematic diagram. Each board illustration can be found on the back side of a foldout page, preceding the schematic diagram(s) to which it relates. If more than one schematic diagram is associated with a particular circuit board, the board illustration is located on a left-hand page preceding the diagram with which the board is first associated.

Also provided in the "Diagrams" section is an illustration of the bottom side of the Main circuit board. This drawing facilitates troubleshooting by showing the connection pads and the location of components that are mounted on the top side of the board. Probing of Main board component signals that are inaccessible from the top side can be achieved without the necessity of disassembling portions of the instrument.

Waveform test-point locations are also identified on the circuit board illustration by hexagonal-outlined numbers that correspond to the waveform numbers appearing on both the schematic diagram and the waveform illustration.

### Circuit Board Locations

An illustration depicting the location of a circuit board within the instrument is shown on the foldout page adjacent to the circuit board illustration.

### Circuit Board Interconnection Diagram

A circuit board cable distribution diagram and connector-pin locator table is provided in the "Diagrams" section to aid in tracing a signal path or power source between boards. All wires, plug and jack numbers are shown along with wire or pin numbers.

### Power Distribution Diagram

A Power Distribution diagram 8 is provided to aid in troubleshooting power-supply problems. This diagram shows service jumpers used to remove power from the various circuit boards. Excessive loading on a power supply by a circuit board can be isolated to the faulty board by disconnecting appropriate service jumpers.

### Grid Coordinate System

Each schematic diagram and circuit board illustration has a grid border along its left and top edges. A table located adjacent to each schematic diagram lists the grid coordinates of each component shown on that schematic. To aid in physically locating a component on the respective circuit board, this table also lists the circuit-board grid coordinate of each component.

Adjacent to each circuit board illustration is an alphanumeric listing of every component mounted on that board. A second column in this listing identifies the schematic diagram in which each component can be found. These component-locator tables are especially useful when more than one schematic diagram is associated with a particular circuit board.

### Troubleshooting Charts

The troubleshooting charts contained in the "Diagrams" section are to be used as an aid in locating malfunctioning circuitry. To use the charts, begin with the Troubleshooting Guide. This chart will help identify a particular problem area for further troubleshooting.

Note that some troubleshooting-procedure boxes on each chart contain numbers along their lower edges. These numbers identify the applicable schematic diagram(s) to be used when performing the action specified in the box.

Both General and Specific notes may be called out in the troubleshooting-chart boxes. These notes are located on the inner panels of the foldout pages. Specific Notes contain procedures or additional information to be used in performing the particular troubleshooting step called for in that box. General Notes contain information that pertains to the overall troubleshooting procedure.

Some malfunctions, especially those involving multiple simultaneous failures, may require more elaborate troubleshooting approaches with references to circuit descriptions in the "Theory or Operation" section of this manual.

### Component Color Coding

Information regarding color codes and markings of resistors and capacitors is located in the color-coding illustration (Figure 9-1) at the beginning of the "Diagrams" section.

**RESISTOR COLOR CODE.** Resistors used in this instrument are carbon-film, composition, or precision metal-film types. They are color coded with the EIA color code; however, some metal-film resistors may have the value printed on the body. The color code is interpreted by starting with the strip that is nearest to one end of the resistor. Composition resistors have four stripes; these represent two significant figures, a multiplier, and a tolerance value. Metal-film resistors have five stripes which represent three significant figures, a multiplier, and a tolerance value.

**CAPACITOR MARKINGS.** Capacitance values of common disc capacitors and small electrolytics are marked on the side of the capacitor body. White ceramic capacitors are color code in picofarads, using a modified EIA code.

Dipped tantalum capacitors are color coded in microfarads. The color dot indicates both the positive lead and the voltage rating. Since these capacitors are easily destroyed by reversed or excessive voltage, be careful to observe the polarity and voltage rating.

**DIODE COLOR CODE.** The cathode end of each glass-encased diode is indicated by either a stripe, a series of stripes, or a dot. For most silicon or germanium diodes marked with a series of stripes, the color combination of the stripes identifies three digits of the Tektronix Part Number, using the resistor color-code system (e.g., a diode having either a pink or a blue strip at the cathode end, then a

brown-gray-green stripe combination, indicates Tektronix Part Number 152-0185-00). The cathode and anode ends of a metal-encased diode can be identified by the diode symbol marked on its body.

### Semiconductor Lead Configurations

Figure 9-2 in the "Diagrams" section shows the lead configurations for semiconductor devices used in the instrument. These lead configurations and case styles are typical of those available at completion of the design of the instrument. Vendor changes and performance improvement changes may result in changes of case styles or lead configurations. If the device in question does not appear to match the configuration in Figure 9-2, examine the associated circuitry or consult a semiconductor manufacturer's data sheet.

### Multipin Connectors

Multipin connector orientation is indicated by two triangles: one on the holder and one on the circuit board. Slot numbers are usually molded into the holder. When a connection is made to circuit-board pins, ensure that the triangle on the holder and the triangle on the circuit board are aligned with each other (see Figure 6-1).

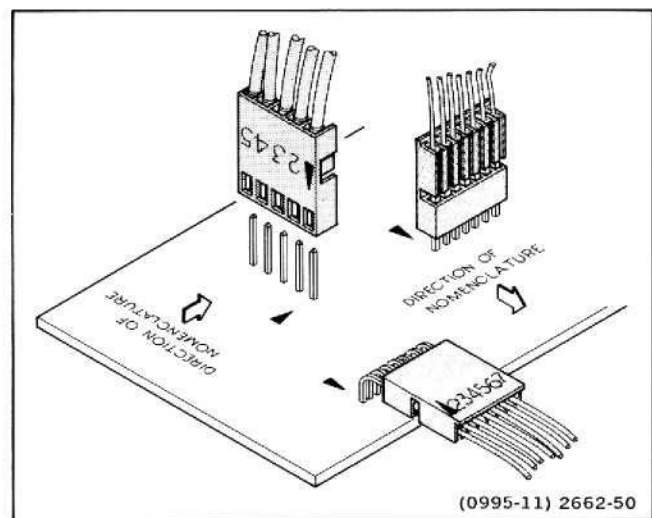

Figure 6-1. Multi-connector holder orientation.

## TROUBLESHOOTING EQUIPMENT

The equipment listed in Table 4-1, or equivalent equipment, may be useful when troubleshooting this instrument.

## TROUBLESHOOTING TECHNIQUE

The following procedure is arranged in an order that enables checking simple trouble possibilities before requiring more extensive troubleshooting. The first four checks ensure proper control settings, connections, operation, and adjustment. If the trouble is not located by these checks, the remaining steps will aid in locating the defective component. When the defective component is located, replace it, using the appropriate replacement procedure given under "Corrective Maintenance" in this section.

### CAUTION

*Before using any test equipment to make measurements on static-sensitive, current-sensitive, or voltage-sensitive components or assemblies, ensure that any voltage or current supplied by the test equipment does not exceed the limits of the component to be tested.*

#### 1. Check Control Settings

Incorrect control settings can give a false indication of instrument malfunction. If there is any question about the correct function or operation of any control, refer to either the "Operating Instructions" (Section 2) in this manual or to the instrument Operators Manual.

#### 2. Check Associated Equipment

Before proceeding, ensure that any equipment used with this instrument is operating correctly. Verify that input signals are properly connected and that the interconnecting cables are not defective. Check the power-input-source voltages.

### WARNING

*To avoid electrical shock, disconnect the instrument from the power-input source before performing visual inspection.*

#### 3. Visual Check

Perform a visual inspection. This check may reveal broken connections or wires, damaged components, semiconductors not firmly mounted, damaged circuit boards, or other clues.

### WARNING

*Dangerous potentials exist at several points throughout this instrument. If it is operated with the cabinet removed, do not touch exposed connections or components.*

#### 4. Check Instrument Performance and Adjustment

Check the performance of either of those circuits where trouble appears to exist or the entire instrument. The apparent trouble may only be the result of misadjustment. Complete performance check and adjustment instructions are given in Sections 4 and 5 of this manual.

#### 5. Isolate Trouble to a Circuit

To isolate problems to a particular area, use the trouble symptom to help identify the circuit in which the trouble is located. Refer to the troubleshooting charts in the "Diagrams" section as an aid in locating a faulty circuit.

#### 6. Check Power Supplies

### WARNING

*For safety reasons an isolation transformer must be connected whenever troubleshooting is done in the Preregulator and the Inverter Power Supply sections.*

Check the power supplies whenever trouble symptoms appear in more than one circuit. The correct output voltage and ripple for each supply should be measured between the supply test point and chassis ground (see Table 6-4 and associated circuit board illustration). Voltages may be measured either by a DMM or an oscilloscope, while the ripple measurements are accomplished only with an oscilloscope. Before checking power-supply circuitry set the A INTENSITY control to minimum brightness and the A SEC/DIV switch to X-Y mode.

When measuring ripple, use a 1X probe with a bayonet signal tip attached to the probe tip to minimize stray pickup.

Insert the bayonet signal tip to the first test point indicated in Table 6-4 and touch the bayonet ground tip to the chassis ground near the test point. The ripple values listed in Table 6-4 are based on a system limited in bandwidth to 30 kHz (greater bandwidth will result in higher readings).

If power supply voltages and ripple are within the listed ranges, the supply can be assumed to be operating correctly. If any are outside these ranges, the supply may be either misadjusted or operating incorrectly. Use the "Power Supply, Display, and Z-Axis" section in the "Adjustment" procedure to adjust the -8.6 V supply.

A defective component elsewhere in the instrument can create the appearance of a power-supply problem and may also affect the operation of other circuits.

**Table 6-4**  
**Power Supply Limits and Ripple**

Power Supply	Test Point	Reading (Volts)	P-P Ripple (mV)
-8.6 V	TP961	-8.56 to -8.64	1.5
+5.2 V	W968	+5.04 to +5.36	3.0
+8.6 V	W960	+8.43 to +8.77	1.5
+30 V	W956	+29.1 to +30.9	20.0
+100 V	W954	+97.0 to +103.0	40.0

**7. Check Circuit Board Interconnections**

After the trouble has been isolated to a particular circuit, again check for loose or broken connections and heat-damaged components.

**8. Check Voltages and Waveforms**

Often the defective component can be located by checking the appropriate voltage or waveform in the circuit. Typical voltages are listed on the schematic diagrams. Waveforms are shown adjacent to the schematics, and waveform test points are indicated on both the schematics and circuit board illustrations by hexagonal-outlined numbers.

**NOTE**

*Voltages and waveforms given on the schematic diagrams are not absolute and may vary slightly between instruments. To establish operating conditions similar to those used to obtain these readings, see the "Voltage and Waveform Setup" conditions in the "Diagrams" section for the preliminary equipment setup. Note the recommended test equipment, initial front-panel control settings, and cable-connection instructions. The control-setting changes (from initial setup) required to obtain the given waveforms and voltages are located on the waveform-diagram page.*



*To avoid electric shock, always disconnect the instrument from the power input source before removing or replacing components.*

**9. Check Individual Components**

The following procedures describe methods of checking individual components. Two-lead components that are soldered in place are most accurately checked by first disconnecting one end from the circuit board. This isolates the measurement from the effects of surrounding circuitry. See Figure 9-1 for value identification or Figure 9-2 for typical semiconductor lead configuration.



*When checking semiconductors, observe the static-sensitive precautions located at the beginning of this section.*

**TRANSISTORS.** A good check of transistor operation is actual performance under operating conditions. A transistor can most effectively be checked by substituting a known good component. However, be sure that circuit conditions are not such that a replacement transistor might also be damaged. If substitute transistors are not available, use a dynamic tester. Static-type testers are not recommended, since they do not check operation under simulated operating conditions.

When troubleshooting transistors in the circuit with a voltmeter, measure both the emitter-to-base and emitter-to-collector voltages to determine whether they are consistent with normal circuit voltages. Voltages across a transistor may vary with the type of device and its circuit function.

Some of these voltage are predictable. The emitter-to-base voltage for a conducting silicon transistor will normally range from 0.6 to 0.8 V. The emitter-to-collector voltage for a saturated transistor is about 0.2 V. Because these values are small, the best way to check them is by connecting a sensitive voltmeter across the junction rather than comparing two voltages taken with respect to ground. If the former method is used, both leads of the voltmeter must be isolated from ground.

If values less than these are obtained, either the device is shorted or no current is flowing in the external circuit. If values exceed the emitter-to-base values given, either the junction is reverse biased or the device is defective. Volt-

ages exceeding those given for typical emitter-to-collector values could indicate either a nonsaturated device operating normally or a defective (open-circuited) transistor. If the device is conducting, voltage will be developed across the resistors in series with it; if it is open, no voltage will be developed across the resistors in series with it, unless current is being supplied by a parallel path.

**CAUTION**

*When checking emitter-to-base junctions, do not use an ohmmeter range that has either a high internal current or voltage. High current or high voltage can damage the transistor. Reverse biasing the emitter-to-base junction with a high current may degrade the transistor's current-transfer ratio (Beta).*

A transistor emitter-to-base junction also can be checked for an open or shorted condition by measuring the resistance between terminals with an ohmmeter set to a range having a low internal source current, such as the R X 1 k $\Omega$  range. The junction resistance should be very high in one direction and very low when the meter leads are reversed.

When troubleshooting a field-effect transistor, the voltage across its elements can be checked in the same manner as previously described for other transistors. However, remember that in the normal depletion mode of operation, the gate-to-source junction is reverse biased; in the enhanced mode, the junction is forward biased.

**INTEGRATED CIRCUITS.** An integrated circuit (IC) can be checked with a voltmeter, test oscilloscope, or by direct substitution. A good understanding of circuit operation is essential to troubleshooting a circuit having an IC. Use care when checking voltages and waveforms around the IC so that adjacent leads are not shorted together. The grabber tip or an IC test clip provides a convenient means of clipping a test probe to an IC.

**CAUTION**

*When checking a diode, do not use an ohmmeter range that has a high internal current. High current can damage the diode. Checks on diodes can be performed in much the same manner as on transistor emitter-to-base junctions; use a dynamic tester, such as the TEKTRONIX 576 Curve Tracer.*

**DIODES.** A diode can be checked for either an open or a shorted condition by measuring the resistance between terminals with an ohmmeter set to a range having a low internal source current, such as the R X 1 k $\Omega$  range. The diode resistance should be very high in one direction and very low when the meter leads are reversed.

When conducting, silicon diodes should have 0.6 to 0.8 V across their junctions, and schottky diodes should have 0.2 to 0.4 V across their junctions. Higher readings indicate that they are either reverse biased or defective, depending on polarity.

**RESISTORS.** Check resistors with an ohmmeter. Refer to the "Replaceable Electrical parts" list for the tolerances of resistors used in this instrument. A resistor normally does not require replacement unless its measured value varies widely from its specified value and tolerance.

**INDUCTORS.** Check for open inductors by checking continuity with an ohmmeter. Shorted or partially shorted inductors can usually be found by checking the waveform response when high-frequency signals are passed through the circuit.

**CAPACITORS.** A leaky or shorted capacitor can best be detected by checking resistance with an ohmmeter set to one of the highest ranges. Do not exceed the voltage rating of the capacitor. The resistance reading should be high after the capacitor is charged to the output voltage of the ohmmeter. An open capacitor can be detected with a capacitance meter or by checking whether the capacitor passes ac signals.

## 10. Repair and Adjust the Circuit

If any defective parts are located, follow the replacement procedures given under "Corrective Maintenance" in this section. After any electrical component has been replaced, the performance for that particular circuit should be checked, as well as the performance of other closely related circuits. Since the power supplies affect all circuits, performance of the entire instrument should be checked if work has been done in any of the power supplies or if the power transformer has been replaced. Readjustment of the affected circuitry may be necessary. Refer to the "Performance Check Procedure" and "Adjustment Procedure" (Sections 4 and 5) and to Table 5-1 (Adjustment Interactions).

# CORRECTIVE MAINTENANCE

## INTRODUCTION

Corrective maintenance consists of component replacement and instrument repair. This part of the manual describes special techniques and procedures required to replace components in this instrument. If it is necessary to ship your instrument to a Tektronix Service Center for repair or service, refer to the "Repackaging for Shipment" instructions at the end of this section.

## MAINTENANCE PRECAUTIONS

To reduce the possibility of personal injury or instrument damage, observe the following precautions.

1. Disconnect the instrument from the ac power input source before removing or installing components.
2. Use care not to interconnect instrument grounds which may be at difference potentials (cross grounding).

## OBTAINING REPLACEMENT PARTS

Most electrical and mechanical parts can be obtained through your local Tektronix Field Office or representative. However, many of the standard electronic components can usually be obtained from a local commercial source. Before purchasing or ordering a part from a source other than Tektronix, Inc., please check the "Replaceable Electrical Parts" list (Section 7) for the proper value, rating, tolerance, and description.

### NOTE

*Physical size and shape of a component may affect instrument performance, particularly at high frequencies. Always use direct-replacement components, unless it is known that a substitute will not degrade instrument performance.*

## Special Parts

In addition to the standard electronic components, some special parts are used in this instrument. These parts are manufactured or selected by Tektronix, Inc. to meet specific performance requirements, or are manufactured for Tektronix, Inc. in accordance with our specifications. The various manufacturers can be identified by referring to the "Cross Index-Mfr Code Number to Manufacturer" at the be-

ginning of the "Replaceable Electrical Parts" list. Most of the mechanical parts used in this instrument were manufactured by Tektronix, Inc. Order all special parts directly from your local Tektronix Field Office or representative.

## Ordering Parts

When ordering replacement parts from Tektronix, Inc., be sure to include all of the following information:

1. Instrument type (include modification or option numbers).
2. Instrument serial number.
3. A description of the part (if electrical, include its component number).
4. Tektronix part number.

## MAINTENANCE AIDS

The maintenance aids listed in Table 6-5 include items required for performing most of the maintenance procedures on this instrument. Equivalent product may be substituted for the examples given, provided their characteristics are similar.

## INTERCONNECTIONS

Pin connectors are used to connect wires to the interconnecting pins. They are grouped together and mounted in a plastic holder and should be removed, reinstalled, or replaced as a unit. If an individual wire or connector in the assembly is faulty, the entire cable assembly should be replaced. To provide correct orientation of this multipin connector when it is reconnected to its mating pins, an arrow is stamped on the circuit board, and a matching arrow is molded into the plastic housing of the multipin connector. Be sure these arrows are aligned with each other when the multipin connector is reinstalled.

### NOTE

*The individual wires on the Front Panel & Filter circuit boards to the Main circuit board may be replaced individually. The pins from the Alternate SYNC Board may also be replaced individually.*

**Table 6-5**  
**Maintenance Aids**

<b>Description</b>	<b>Specifications</b>	<b>Usage</b>	<b>Example</b>
1. Soldering Iron	15 to 25 W.	General soldering and unsoldering.	Antex Precision Model C.
2. Torx Screwdrivers	Torx tips #T7, #T9, #T10, #T15 and #T20.	Assembly and disassembly.	Tektronix Part Numbers (#T7) 003-1293-00 (#T9) 003-0965-00 (#T10) 003-0814-00 (#T15) 003-0966-00 (#T20) 003-0866-00
3. Nutdrivers	1/4 inch, 5/16 inch, 1/2 inch, and 9/16 inch	Assembly and disassembly.	Xcelite #8, #10, #16, and #18.
4. Open-end wrench	9/16 inch	Assembly and disassembly.	
5. Hex Wrenches	0.050 inch and 1/16 inch.	Assembly and disassembly	Allen Wrenches
6. Long-nose Pliers		Component removal and replacement.	
7. Diagonal Cutters		Component removal and replacement.	
8. Vacuum Solder Extractor	No static charge retention	Unsoldering components.	Pace Model PC-10.
9. Lubricant	No-Noise.	Switch lubrication.	Tektronix Part Number 006-0442-02.
10. Pin-replacement kit		Replace circuit board connector pins.	Tektronix Part Number 040-0542-00.
11. Isolation Transformer		Isolate the instrument from the ac-power-source outlet.	Tektronix Part Number 006-5953-00.
12. 1X Probe		Power supply ripple check.	TEKTRONIX P6101 Probe (1X). Part Number 010-6101-03.
13. Bayonet Ground Assembly		Signal interconnection.	Tektronix Part Number 013-0085-00.

## TRANSISTORS AND INTEGRATED CIRCUITS

Transistors and integrated circuits should not be replaced unless they are actually defective. If unsoldered from the circuit board during routine maintenance, return them to their original board locations. Unnecessary replacement or transposing of semiconductor devices may affect the adjustment of the instrument. When a semiconductor is replaced, check the performance of any instrument circuit that may be affected.

Any replacement components should be of the original type or a direct replacement. Bend transistor leads to fit their circuit board holes and cut the leads to the same length as the original component. See Figure 9-2 for typical lead-configuration illustrations.

To remove a soldered dual-in-line packaged (DIP) IC, do not heat adjacent conductors consecutively. Apply heat to pins at alternate sides and ends of the IC as solder is removed. Allow a moment for the circuit board to cool before proceeding to the next pin.

The heat-sink-mounted power supply transistors are insulated from the heat sink. In addition, a heat-sink compound is used to increase heat transfer capabilities. Reinstall the insulators and replace the heat-sink compound when replacing these transistors. The compound should be applied to both sides of the insulators and should be applied to the bottom side of the transistor where it comes in contact with the insulator.

**NOTE**

*After replacing a power transistor, check that the collector is not shorted to the heat sink before applying power to the instrument.*

## SOLDERING TECHNIQUES

The reliability and accuracy of this instrument can be maintained only if proper soldering techniques are used to remove or replace parts. General soldering techniques, which apply to maintenance of any precision electronic equipment, should be used when working on this instrument.

If obtained apart from the associated equipment and from any vendor other than aa4df or ralph.d.miller, you have been sold stolen property. Please demand a refund, and if applicable, file a complaint with eBay.

**WARNING**

*To avoid an electric-shock hazard, observe the following precautions before attempting any soldering: turn the instrument off, disconnect it from the ac power source, and allow approximately three minutes for the power-supply capacitors to discharge.*

Use rosin-core wire solder containing 63% tin and 37% lead. Contact your local Tektronix Field Office or representative to obtain the names of approved solder types.

When soldering on circuit boards or small insulated wires, use only a 15- to 25-watt, pencil-type soldering iron. A higher wattage soldering iron can cause etched circuit conductors to separate from the board base material and melt the insulation on small wires. Always keep the soldering-iron tip properly tinned to ensure best heat transfer from the iron tip to the solder joint. To protect heat-sensitive components, either hold the component lead with long-nose pliers or place a heat block between the component body and the solder joint. Apply only enough solder to make a firm joint. After soldering, clean the area around the solder connection with an approved flux-removing solvent (such as isopropyl alcohol) and allow it to air dry.

**CAUTION**

*Attempts to unsolder, remove, and resolder leads from the component side of a circuit board may cause damage to the reverse side of the circuit board.*

The following techniques should be used to replace a component on any of the circuit boards:

1. Touch the vacuum desoldering tool to the lead at the solder connection. Never place the iron directly on the board; doing this may damage the board.

**NOTE**

*Some components are difficult to remove from the circuit board due to a bend placed in each lead during machine insertion of the component. The purpose of the bent leads is to hold the component in place during a solder-flow manufacturing process that solders all the components at once. To make removal of machine-inserted components easier, straighten the component leads on the reverse side of the circuit board with a small screwdriver or pliers. It may be necessary to remove the circuit board to gain access to the component leads on the reverse side of the circuit board. Circuit-board removal and reinstallation procedures are discussed later in this section.*

2. When removing a multipin component, especially an IC, do not heat adjacent pins consecutively. Apply heat to pins at alternate sides and ends of the IC as solder is removed. Allow a moment for the circuit board to cool before proceed to the next pin.

**CAUTION**

*Excessive heat can cause the etched circuit conductors to separate from the circuit board. Never allow the solder extractor tip to remain at one place on the board for more than three seconds. Solder wick, spring-actuated or squeeze-bulb solder suckers, and heat blocks (for desoldering multipin components) must not be used. Damage caused by poor soldering techniques can void the instrument warranty.*

3. To replace the component, bend the leads of the replacement item to fit the holes in the circuit board. If the component is replaced while the board is installed in the instrument, cut the leads so they protrude only a small amount through the reverse side of the circuit board. Excess lead length may cause shorting to other conductive parts.

4. Insert the leads into the holes of the board so that the replacement component is positioned the same as the original component. Most components should be firmly seated against the circuit board.

5. Touch the soldering iron to the connection and apply enough solder to make a firm solder joint. Do not move the component while the solder hardens.

6. Cut off any excess lead protruding through the circuit board (if not clipped to size in step 3).

7. Clean the area around the solder connection with an approved flux-removing solvent. Be careful not to remove any of the printed information from the circuit board.

## REMOVAL AND REPLACEMENT INSTRUCTIONS

The exploded view drawings in the “Replaceable Mechanical Parts” list (Section 9) may be helpful during the removal and reinstallation of individual subassemblies or components. Circuit board and component locations are shown in the “Diagrams” section.

### Cabinet

#### WARNING

*To avoid electric shock, disconnect the instrument from the ac-power-input source before removing or replacing any component or assembly.*

To remove the instrument cabinet, perform the following steps:

1. Disconnect the power cord from the instrument. For instruments with a power-cord securing clamp; remove the Phillips-head screw holding the power-cord securing clamp before disconnecting the power cord.

2. Remove the screw from the right-rear side of the cabinet and two screws from the rear panel. Then remove the rear panel.

3. Pull the front panel and attached chassis forward and out of the cabinet.

To reinstall the cabinet, perform the following steps:

4. Slide the chassis frame into the cabinet from the front until the cabinet is fully into the front-panel groove and the rear of the cabinet is flush with the rear of the chassis.

5. Align the rear-panel and the side mounting holes with the screw holes in the chassis frame and reinstall the three screws removed in step 2.

#### CAUTION

*To ensure that the cabinet is grounded to the instrument chassis, the screw at the right rear side of the cabinet must be tightly secured.*

6. Reconnect the power cord (reinstall the securing clamp and screw removed in step 1 if applicable).

### Cathode-Ray Tube

#### WARNING

*Use care when handling a crt. Breakage of the crt may cause high-velocity scattering of glass fragments (implosion). Protective clothing and safety glasses should be worn. Avoid striking the crt on any object which may cause it to crack or implode. When storing a crt, either place it in a protective carton or set it face down on a smooth surface in a protected location with a soft mat under the faceplate.*

To remove the crt, perform the following steps:

1. Disconnect four deflection-plate wires at the middle of the crt neck and unplug the Trace Rotation connector (P9006) from the Front-Panel circuit board (note the connection locations and wire colors for reinstallation reference).

#### WARNING

*The crt anode lead and the High-Voltage Multiplier output lead retain a high-voltage charge after the instrument is turned off. To avoid electrical shock, disconnect the High-Voltage Multiplier lead from the crt anode lead and ground both leads to the main instrument chassis.*

## Maintenance—2235 Service

2. Unplug the crt anode lead connector from the High-Voltage Multiplier lead located on left side of Power-Supply shield and discharge it to the chassis.

3. Remove two front panel screws that retain the plastic crt frame and light filter to the front panel. Remove the crt frame and light filter from the instrument.

4. With the rear of the instrument facing you, place the fingers of both hands over the front edge of the front subpanel. Then, using both thumbs, press forward gently on the crt funnel near the front of the crt. When the crt base pins disengage from the socket, remove the crt and the crt shield through the instrument front subpanel. Place the crt in a safe place until it is ready to reinstall. If the plastic crt corner pads fall out, save them for reinstallation.

5. Remove the crt socket cover and cap from the rear of the crt socket for reinstallation.

To reinstall the crt, perform the following steps:

6. Reinstall any plastic crt corner pads that are out of place. Insert the crt, crt shield, anode lead, and Trace Rotation leads through the front-panel opening. Make sure all pins are straight and that the indexing keys on the crt base, socket, and shield are aligned. Make sure that the ground clip makes contact only with the outside of the crt shield.

7. Push the crt base into the socket. Verify that the crt base and socket are flush together as viewed from the rear and that the crt is seated properly in the front-panel opening.

8. Reinstall the crt socket cap and cover to the rear of the crt socket (removed in step 5).

9. Reinstall the crt frame and light filter; then secure them with two front panel screws (removed in step 3).

10. Reconnect the crt anode lead to the High-Voltage Multiplier (disconnected in step 2).

11. Reconnect the four deflection-plate wires and the Trace Rotation connector (disconnected in step 1).

### Power-Supply Shield

To remove the Power-Supply shield, perform the following steps:

1. Remove the screw from the plastic power-supply cover on the bottom section of the Main circuit board. Press gently on the rear of the cover and slide it forward.

2. Remove the screw securing the Power-Supply shield to the Main circuit board (located at the bottom of the circuit board near the middle right side of the frame).

3. Remove two screws securing the left rear of the Power-Supply shield to the back of the chassis frame.

4. Remove the crt anode lead from the anode clip on the side of the Power-Supply shield.

5. Remove the screw from the front upper right-hand corner of the Power-Supply shield.

6. Lift the shield up and out of the chassis frame by removing the right rear corner first.

To reinstall the Power-Supply shield, perform the following steps:

7. Insert the shield into the chassis frame. Make sure that the shield's right and back edges are in their chassis frame guides, that the crt socket-wire assembly is in its cut-out, and that the Alt Sweep board is in its plastic holder.

8. Reinstall the screw at the upper right-hand corner of the shield (removed in step 5).

9. Reinstall the crt anode lead into the anode clip on the side of the Power-Supply shield (removed in step 4).

10. Reinstall two screws securing the shield to the back of the chassis frame (removed in step 3).

11. Reinstall the screw holding the shield to the Main circuit board at the right side of the frame (removed in step 2).

12. Reinstall the plastic power-supply cover on the bottom of the Main circuit board and secure both the shield and the cover with one screw (removed in step 1).

### Filter Circuit Board

To remove the Filter circuit board, perform the following steps.

1. Remove the Power-Supply shield (see the “Power-Supply Shield” removal procedure).

2. Remove the five wires to the Filter circuit board by unsoldering two wires from the Main circuit board, two from the line filter, and one wire from the fuse holder (pull the protective cap completely off the fuse holder before unsoldering).

3. Remove two screws securing the Filter circuit board to the back of the chassis frame. Lift the Filter circuit board out of the instrument.

To reinstall the Filter circuit board, perform the following steps.

4. Reinstall two screws securing the Filter circuit board to the back of the chassis frame (removed in step 3).

5. Resolder the five wires from the Filter circuit board to the Main circuit board, line filter, and fuse holder (unsoldered in step 2).

6. Reinstall the Power-Supply shield (see the “Power-Supply Shield” reinstallation procedure).

### Alt Sweep Circuit Board

To remove the Alt Sweep circuit board, perform the following steps:

1. Use a vacuum-desoldering tool to unsolder the 27 pins (between the Alt Sweep circuit board and the Main circuit board) from the Main circuit board.

2. Remove the Alt Sweep circuit board from the instrument by unclipping it from the plastic holder attached to the Power-Supply shield.

To reinstall the Alt Sweep circuit board, perform the following steps:

3. Insert the 27 pins of the Alt Sweep circuit board into the Main circuit board.

4. Reinstall the Alt Sweep circuit board into the plastic holder attached to the Power-Supply shield.

5. Resolder the 27 pins to the Main circuit board (unsoldered in step 1).

### Attenuator Circuit Board

To remove the Attenuator circuit board, perform the following steps:

1. Use a 1/16-inch Hex-key wrench to loosen the set screws on both the CH 1 and the CH 2 VOLTS/DIV Variable knobs and remove the knobs.

2. Set the CH 1 and the CH 2 VOLTS/DIV switches to the same position. Note switch positions for reinstallation reference; then remove the knobs by pulling them straight out from the front panel.

3. Place the instrument on its side and remove two screws securing the Attenuator board to the subpanel (located underneath the CH 1 and CH 2 input connectors).

4. Unsolder the resistors from the CH 1 and CH 2 input connectors.

5. Remove the following connectors from the Attenuator circuit board, noting their locations for reinstallation reference:

- a. P9103, a four-wire connector located behind the CH 1 VOLTS/DIV switch assembly.
- b. P9108, a four-wire connector located behind the CH 2 VOLTS/DIV switch assembly.
- c. P9091, a three-wire connector located between the Channel 1 and Channel 2 Variable potentiometers at the rear of the Attenuator circuit board.

6. Remove four screws securing the Top shield to both the Attenuator circuit board and the bottom shield.

7. Remove two screws and the ground strap from the rear of the Attenuator circuit board.

8. Pull the Attenuator board straight back from the front of the instrument until the circuit board interconnecting pins are disengaged and the switch shafts are clear of both the Front-Panel circuit board and the two AC-GND-DC switch shafts (located between the front-panel and the subpanel).

To reinstall the Attenuator circuit board, perform the following steps:

9. Insert the two VOLTS/DIV switch shafts and the AC-GND-DC switch shafts into the front panel holes. Ensure that the interconnecting pins are aligned with the Front-Pan-

## Maintenance—2235 Service

el circuit board connectors and that the two resistors (soldered to the bottom of the Attenuator circuit board) do not touch the Front-Panel circuit board. Push the Attenuator circuit board forward and, at the same time press the front end of the board down slightly. Align the two AC-GND-DC switch shafts with the front-panel holes by moving either the Channel 1 or the Channel 2 AC-GND-DC switch knob.

10. Reinstall two screws and ground strap to the rear of the Attenuator circuit board (removed in step 7).

11. Replace the top shield and reinstall the four screws and ground strap from the rear of the attenuator board to the top shield (removed in step 6).

12. Reconnect three connectors to the Attenuator circuit board disconnected in step 5.

13. Place the instrument on its side and reinstall two screws to the subpanel (removed in step 4).

14. Resolder the resistors to the CH 1 and CH 2 input connectors (disconnected in step 3).

15. Reinstall the two VOLTS/DIV knobs at the positions noted in step 2.

16. Rotate the two Variable control shafts fully clockwise to their calibrated detent positions.

17. Reinstall the Variable knobs onto their shafts (with lettering horizontal and right-side up) and tighten the set screws.

### Timing Circuit Board

To remove the Timing circuit board, perform the following steps.

1. Use a 1/16-inch Hex-key wrench to loosen the set screw of the SEC/DIV Variable knob.

2. Lock the A and B SEC/DIV knobs together and note the position for reinstallation reference. Use a 1/4-inch nut driver to remove the nut securing the B SEC/DIV knob; pull off the knob and collet from the shaft assembly.

3. Use a 1/16-inch Hex-key wrench to loosen two set screws securing the A SEC/DIV dial to the shaft assembly.

4. Remove the following connectors from the Timing circuit board.

a. P9705, an eight-wire connector located at the rear of the Timing circuit board.

b. P9700, a 10-wire connector located on the right edge of the Timing circuit board.

5. Remove one screw at the rear of the Attenuator circuit board (securing both the Attenuator and the Timing circuit boards to the Bottom shield).

6. Remove the remaining three screws securing the Timing circuit board to the Bottom shield.

7. Pull the Timing circuit board straight back from the front of the instrument until the circuit board interconnecting pins are disengaged and the switch shaft is clear of the Front-Panel circuit board.

To reinstall the Timing circuit board, perform the following steps:

8. Insert the SEC/DIV switch shaft through the hole in the Front-Panel circuit board, ensuring that the interconnecting pins are aligned with the Front-Panel connectors. Push the Timing circuit board forward into position.

9. Reinstall three screws securing the Timing circuit board to the bottom shield (removed in step 6).

10. Reinstall the remaining screw at the rear of the Attenuator circuit board securing both the Attenuator and the Timing circuit boards to the bottom shield (removed in step 5).

11. Reconnect two connectors to the Timing circuit board (disconnected in step 4).

12. Reinstall the A SEC/DIV dial in the position noted in step 3 and secure it with two set screws.

13. Reinstall the collet and the B SEC/DIV knob at the position noted in step 2 and secure it with the nut.

14. Reinstall the SEC/DIV Variable knob onto its shaft (with lettering horizontal and right-side up) and tighten the set screw.

### Bottom Shield, Attenuator and Timing Circuit-Board Module

Removal of the module consisting of the Bottom shield and the Attenuator and Timing circuit boards is accomplished by the following steps:

1. Perform steps 1 through 5 under the "Attenuator Circuit Board" removal procedure.
2. Perform steps 1 through 4 under the "Timing Circuit Board" removal.
3. Place the instrument on its side and remove four screws holding the Bottom shield to the Main circuit board.
4. Pull the Bottom shield, along with the Attenuator and Timing circuit boards straight back from the front of the instrument until the interconnecting pins on both circuit boards are disengaged and the switch shafts are clear of the holes in the Front-Panel circuit board; then lift out the entire assembly through the top of the instrument.
5. If accessibility to the bottom of either the Attenuator or the Timing circuit board is desired refer to steps 6 and 7 of the "Attenuator Circuit Board" removal procedure and to steps 5 and 6 of the "Timing Circuit Board" removal procedure.

To reinstall the Bottom shield-Attenuator-Timing assembly, perform the following steps:

6. If one or both of the circuit boards was removed, reinstall the circuit board(s) to the Bottom shield by referring to steps 10 and 11 of the "Attenuator Circuit Board" reinstallation procedure and to steps 9 and 10 of the "Timing Circuit Board" reinstallation procedure.
7. Insert the three switch shafts through the holes in both the Front-Panel circuit board and the front panel (refer to the "Attenuator Circuit Board" and the "Timing Circuit Board" reinstallation procedures).
8. Reinstall the four screws holding the Bottom shield to the Main circuit board (removed in step 3).
9. Complete reinstallation of the module by performing steps 12 through 17 of the "Attenuator Circuit Board"

reinstallation procedure and steps 11 through 14 of the "Timing Circuit Board" reinstallation procedure.

### Front-Panel Circuit Board

1. Remove the crt (see the "Cathode-Ray Tube" removal procedure).
2. Remove the Bottom shield, Attenuator, and Timing circuit-board module (see the preceding removal procedure).
3. Remove the knobs from the following control shafts by pulling them straight out from the front panel:
  - a. Channel 1 and Channel 2 POSITION,
  - b. A/B SWP SEP,
  - c. Horizontal POSITION,
  - d. A TRIGGER LEVEL,
  - e. B TRIGGER LEVEL.
4. Unsolder both the resistor to the EXT INPUT center connector and the wire strap to the EXT INPUT ground lug.
5. Unsolder the single wire from the PROBE ADJUST connector and the two wires from the VAR HOLDOFF control (leading to the Front-Panel circuit board).
6. Remove the following screws:
  - a. Three screws securing the upper part of the Front-Panel circuit board to the front panel.
  - b. Two recessed frame-securing screws at the left-rear corner of the chassis frame.
  - c. Two screws holding the Main circuit board to the chassis frame.
  - d. One screw securing the delay line to the chassis frame on the left side of the instrument.
  - e. Two recessed frame-securing screws at the right front corner.
7. Pull the front-left frame assembly apart from the rear-right frame assembly.

**NOTE**

*At this point, any component on the Front-Panel circuit board may be accessed for removal and replacement. Skip to step 11 of this procedure after component replacement. If circuit board replacement is intended, continue with the remaining disassembly steps.*

8. Use a vacuum-desoldering tool to unsolder the 39 wire straps from the Main circuit board (connecting to the Front-Panel circuit board).

9. Remove the Front-Panel circuit board from the instrument and clean the wire-strap holes on the Main circuit board of any remaining solder.

**NOTE**

*If a vacuum-desoldering tool is not available, lift each strap out of the Main circuit board as the joint is heated.*

To reinstall the Front-Panel circuit board, perform the following steps:

10. Insert and resolder the 39 wire straps on the Front-Panel circuit board into their corresponding holes in the Main circuit board (unsoldered in step 8).

11. Align the two chassis frame assemblies disassembled in step 7, making sure the POWER switch extension-shaft button is properly placed in the front panel.

12. Reinstall four chassis-frame securing screws, two screws securing the Main circuit board to the chassis frame, and one screw securing the delay line to the chassis frame (removed in step 6, parts b through e).

13. Push the Front-Panel circuit board forward and insert the control shafts, push buttons, and three-position slide switches into their corresponding front-panel holes.

14. Reinstall three screws securing the Front-Panel circuit board to the front-panel (removed in step 6, part a).

15. Resolder the single wire to the PROBE ADJUST connector and the two wires to the VAR HOLDOFF control (unsoldered in step 5).

16. Resolder the resistor to the EXT INPUT center connector and the wire strap to the EXT INPUT ground lug (unsoldered in step 4).

17. Replace the front-panel knobs (removed in step 3).

18. Reinstall the Bottom shield, Attenuator, and Timing circuit-board module (see the preceding reinstallation procedure).

19. Reinstall the crt (see the "Cathode-Ray Tube" reinstallation procedure).

**Main Circuit Board**

All components on the Main circuit board are accessible either directly or by removing either the crt, the Bottom shield, Attenuator, Timing circuit-board module, or the Power-Supply shield. Removal of the Main circuit board is required only when it is necessary to replace the board with a new one.

To remove the Main circuit board, perform the following steps:

1. Disconnect the three-wire B DELAY TIME POSITION potentiometer connector (P4644) from the Main circuit board (located in front of the Power-Supply shield).

2. Remove the Alt Sweep circuit board (see "Alt Sweep Circuit Board" removal procedure).

3. Remove the Power-Supply shield and plastic power-supply cover (see "Power-Supply Shield" removal procedure).

4. Unsolder five wires from the Filter circuit board (leading to the Main circuit board).

5. Remove connectors from the Attenuator and Timing circuit boards, noting their locations for reinstallation reference.

6. Remove the FOCUS control shaft assembly by pulling it straight out from the front panel.

7. Remove the POWER switch extension-shaft assembly by first pressing in the POWER button to the ON position. Then insert a scribe (or similar tool) into the notch between the end of the switch shaft and the end of the extension shaft and gently pry the connection apart. Push the extension shaft forward, then sideways, to clear the switch shaft. Finally, pull the extension shaft back and out of the instrument.

8. Disconnect P9001 and P9002 from the rear of the Main circuit board near the fuse holder.

9. Unsolder the rear-panel EXT Z AXIS connector wire from the Main circuit board.

10. Remove two screws securing the power-supply transistor heat-sink assembly (at the right side of the chassis frame).

**WARNING**

*The crt anode lead and the output terminal to the High-Voltage Multiplier will retain a high-voltage charge after the instrument is turned off. To avoid electrical shock, ground the crt side of the anode lead to the main instrument chassis.*

11. Disconnect the crt anode lead from the High-Voltage Multiplier anode lead by carefully pulling the anode plug out of the jack. Discharge the plug tip to the chassis.

12. Unsolder two sets of crt socket wires from the Main circuit board, noting wire color and position for reinstallation reference.

13. Unsolder two sets of delay-line wires from the Main circuit board, noting wire color and position for reinstallation reference.

14. Remove three screws securing the Bottom shield to the Main circuit board.

15. Remove three screws securing the Main circuit board to the instrument chassis frame (one under the EXT Z AXIS connector and two along the left side of the Main circuit board).

16. Use a vacuum-desoldering tool to unsolder the 39 wire straps (connecting the Main circuit board to the Front-Panel circuit board) from the Main circuit board.

**NOTE**

*If a vacuum-desoldering tool is not available, lift each wire strap out of the Main circuit board as the joint is heated. Use care to maintain, as nearly as possible, the original shape and spacing of the wire straps to facilitate replacing the circuit board.*

17. Push the wire-strap connection end of the Main circuit board down until it is clear of all wire strap ends; then remove it through the bottom of the instrument frame. Ensure that the wire straps are not bent out of place.

To replace the Main circuit board, use the following procedure:

18. Place the Main circuit board into the chassis frame, ensuring that the board is in the guides at the rear and right side of the frame and that the 39 wire straps are inserted into their corresponding holes.

19. Reinstall three screws securing the Main circuit board to the chassis frame (removed in step 15).

20. Resolder 39 wire straps to the Main circuit board.

21. Reinstall three screws holding the bottom shield to the Main circuit board (removed in step 14).

22. Resolder two sets of delay-line wires at the locations noted in step 13.

23. Resolder two sets of crt socket wires at the locations noted in step 12.

24. Reconnect the crt anode lead to the High-Voltage Multiplier anode lead (disconnect in step 11).

25. Reinstall two securing screws in the power-supply transistor heat sink assembly (removed in step 10).

26. Insert and resolder the EXT Z AXIS connector wire into the Main circuit board (removed in step 9).

## Maintenance—2235 Service

27. Reconnect P9001 and P9002 to the Main circuit board (removed in step 8).

28. Insert the POWER switch extension-shaft assembly into the front panel (from the rear). Push the POWER switch to the ON lock position and align the extension shaft with the switch shaft. Press them together gently until they snap into place.

29. Reinstall the FOCUS control shaft assembly (removed in step 6).

30. Reconnect the connectors to the Attenuator and Timing circuit boards (removed in step 5).

31. Resolder five wires from the Filter circuit board to the Main circuit board (unsoldered in step 4).

32. Reinstall the Power-Supply shield and plastic power-supply cover (see "Power-Supply Shield" reinstallation procedure).

33. Reinstall the Alt Sweep circuit board (see "Alt Sweep Circuit Board" reinstallation procedure).

34. Reconnect the B DELAY TIME POSITION potentiometer connector (P9644) to the Main circuit board (disconnected in step 1).

## REPACKAGING FOR SHIPMENT

If the instrument is to be shipped to a Tektronix Service Center for service or repair, attach a tag showing; owner (with address) and the name of an individual at your firm

that can be contacted. Include complete instrument serial number and a description of the service required.

Save and reuse the package in which your instrument was shipped. If the original packaging is unfit for use or not available, repackage the instrument as follows:

Surround the instrument with polyethylene sheeting to protect its finish. Obtain a carton of corrugated cardboard having a carton test strength of 275 pounds and having inside dimensions of no less than six inches more than the instrument dimensions. Cushion the instrument by tightly packing three inches of dunnage or urethane foam between carton and instrument, on all sides. Seal carton with shipping tape or industrial stapler.

## SELECTABLE COMPONENTS

If desired, the trigger-system bandwidth of the oscilloscope may be reduced from the normal 20 MHz to frequencies shown in Table 6-6. To alter the bandwidth, remove C419 (component number A1C419 on Diagram 3) from the Main Circuit Board using the steps in the "Soldering Techniques" part of the "Maintenance" section. The capacitor should be a non-polarized type such as a disc-ceramic or equivalent.

**Table 6-6**  
**Trigger Bandwidth Alteration**

Trigger Bandwidth	Capacitor Value
20 MHz	180 pF
10 MHz	390 pF
5 MHz	750 pF
1 MHz	3300 pF
50 kHz	0.068 $\mu$ F
10 kHz	0.33 $\mu$ F

# OPTIONS

There are currently no options for the 2235, except the optional power cords previously described in Section 2.

# REPLACEABLE ELECTRICAL PARTS

## PARTS ORDERING INFORMATION

Replacement parts are available from or through your local Tektronix, Inc. Field Office or representative.

Changes to Tektronix instruments are sometimes made to accommodate improved components as they become available, and to give you the benefit of the latest circuit improvements developed in our engineering department. It is therefore important, when ordering parts, to include the following information in your order: Part number, instrument type or number, serial number, and modification number if applicable.

If a part you have ordered has been replaced with a new or improved part, your local Tektronix, Inc. Field Office or representative will contact you concerning any change in part number.

Change information, if any, is located at the rear of this manual.

### LIST OF ASSEMBLIES

A list of assemblies can be found at the beginning of the Electrical Parts List. The assemblies are listed in numerical order. When the complete component number of a part is known, this list will identify the assembly in which the part is located.

### CROSS INDEX-MFR. CODE NUMBER TO MANUFACTURER

The Mfr. Code Number to Manufacturer index for the Electrical Parts List is located immediately after this page. The Cross Index provides codes, names and addresses of manufacturers of components listed in the Electrical Parts List.

### ABBREVIATIONS

Abbreviations conform to American National Standard Y1.1.

### COMPONENT NUMBER (column one of the Electrical Parts List)

A numbering method has been used to identify assemblies, subassemblies and parts. Examples of this numbering method and typical expansions are illustrated by the following:

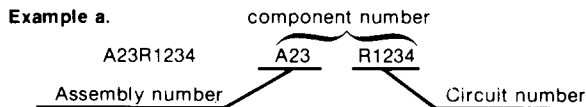

**Read: Resistor 1234 of Assembly 23**

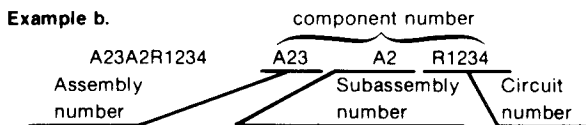

**Read: Resistor 1234 of Subassembly 2 of Assembly 23**

Only the circuit number will appear on the diagrams and circuit board illustrations. Each diagram and circuit board illustration is clearly marked with the assembly number. Assembly numbers are also marked on the mechanical exploded views located in the Mechanical Parts List. The component number is obtained by adding the assembly number prefix to the circuit number.

The Electrical Parts List is divided and arranged by assemblies in numerical sequence (e.g., assembly A1 with its subassemblies and parts, precedes assembly A2 with its subassemblies and parts).

Chassis-mounted parts have no assembly number prefix and are located at the end of the Electrical Parts List.

### TEKTRONIX PART NO. (column two of the Electrical Parts List)

Indicates part number to be used when ordering replacement part from Tektronix.

### SERIAL/MODEL NO. (columns three and four of the Electrical Parts List)

Column three (3) indicates the serial number at which the part was first used. Column four (4) indicates the serial number at which the part was removed. No serial number entered indicates part is good for all serial numbers.

### NAME & DESCRIPTION (column five of the Electrical Parts List)

In the Parts List, an Item Name is separated from the description by a colon (:). Because of space limitations, an Item Name may sometimes appear as incomplete. For further Item Name identification, the U.S. Federal Cataloging Handbook H6-1 can be utilized where possible.

### MFR. CODE (column six of the Electrical Parts List)

Indicates the code number of the actual manufacturer of the part. (Code to name and address cross reference can be found immediately after this page.)

### MFR. PART NUMBER (column seven of the Electrical Parts List)

Indicates actual manufacturers part number.

# Replaceable Electrical Parts—2235 Service

## CROSS INDEX—MFR. CODE NUMBER TO MANUFACTURER

Mfr. Code	Manufacturer	Address	City, State, Zip
000FG	RIFA WORLD PRODUCTS INC.	7625 BUSH LAKE RD P.O. BOX 35263	MINNEAPOLIS, MN 55435
000FG	RIFA WORLD PRODUCTS INC.	7625 BUSH LAKE RD P.O. BOX 35263	MINNEAPOLIS, MN 55435
000FG	RIFA WORLD PRODUCTS INC.	7625 BUSH LAKE RD P.O. BOX 35263	MINNEAPOLIS, MN 55435
000LI	TOPTRON CORP		TOKYO, JAPAN
00853	SANGAMO ELECTRIC CO., S. CAROLINA DIV.	P O BOX 128	PICKENS, SC 29671
01121	ALLEN-BRADLEY COMPANY	1201 2ND STREET SOUTH	MILWAUKEE, WI 53204
01281	TRW ELECTRONIC COMPONENTS, SEMICONDUCTOR OPERATIONS	14520 AVIATION BLVD.	LAWNDALE, CA 90260
01295	TEXAS INSTRUMENTS, INC., SEMICONDUCTOR GROUP	P O BOX 5012, 13500 N CENTRAL EXPRESSWAY	DALLAS, TX 75222
02113	COILCRAFT INC.	1102 SILVER LAKE RD.	CARY, IL 60013
02114	FERROXCUBE CORPORATION	PO BOX 359, MARION ROAD	SAUGERTIES, NY 12477
02735	RCA CORPORATION, SOLID STATE DIVISION	ROUTE 202	SOMERVILLE, NY 08876
03508	GENERAL ELECTRIC COMPANY, SEMI-CONDUCTOR PRODUCTS DEPARTMENT	ELECTRONICS PARK	SYRACUSE, NY 13201
04222	AVX CERAMICS, DIVISION OF AVX CORP.	P O BOX 867, 19TH AVE. SOUTH	MYRTLE BEACH, SC 29577
04713	MOTOROLA, INC., SEMICONDUCTOR PROD. DIV.	5005 E MCDOWELL RD, PO BOX 20923	PHOENIX, AZ 85036
05245	CORCOM INC.	2635 N KILDARE AVENUE	CHICAGO, IL 60639
07263	FAIRCHILD SEMICONDUCTOR, A DIV. OF FAIRCHILD CAMERA AND INSTRUMENT CORP.	464 ELLIS STREET	MOUNTAIN VIEW, CA 94042
08057	MAGNETICS DIV OF SPANG INDST. INC.	230 ADRIAN RD.	MILLBRAE, CA 94030
12697	CLAROSTAT MFG. CO., INC.	LOWER WASHINGTON STREET	DOVER, NH 03820
12969	UNITRODE CORPORATION	580 PLEASANT STREET	WATERTOWN, MA 02172
13511	AMPHENOL CARDRE DIV., BUNKER RAMO CORP.		LOS GATOS, CA 95030
14433	ITT SEMICONDUCTORS	3301 ELECTRONICS WAY P O BOX 3049	WEST PALM BEACH, FL 33402
14552	MICRO SEMICONDUCTOR CORP.	2830 E FAIRVIEW ST.	SANTA ANA, CA 92704
14752	ELECTRO CUBE INC.	1710 S. DEL MAR AVE.	SAN GABRIEL, CA 91776
15238	ITT SEMICONDUCTORS, A DIVISION OF INTER NATIONAL TELEPHONE AND TELEGRAPH CORP.	P.O. BOX 168, 500 BROADWAY	LAWRENCE, MA 01841
15454	RODAN INDUSTRIES, INC.	2905 BLUE STAR ST.	ANAHEIM, CA 92806
18324	SIGNETICS CORP.	811 E. ARQUES	SUNNYVALE, CA 94086
19396	ILLINOIS TOOL WORKS, INC. PAKTRON DIV.	900 FOLLIN LANE, SE	VIENNA, VA 22180
20462	PREM ENTERPRISES, INC.	3519 N. CHAPEL HILL	MCHENRY, IL 60050
20932	EMCON DIV OF ILLINOIS TOOL WORKS INC.	11620 SORRENTO VALLEY RD P O BOX 81542	SAN DIEGO, CA 92121
22229	SOLITRON DEVICES, INC., SEMICONDUCTOR GROUP	8808 BALBOA AVENUE	SAN DIEGO OPERS, CA 92123
22526	BERG ELECTRONICS, INC.	YOUK EXPRESSWAY	NEW CUMBERLAND, PA 17070
24546	CORNING GLASS WORKS, ELECTRONIC COMPONENTS DIVISION	550 HIGH STREET	BRADFORD, PA 16701
26769	NCI INC.	5900 AUSTRALIAN AVENUE	WEST PALM BEACH, FL 33407
27014	NATIONAL SEMICONDUCTOR CORP.	2900 SEMICONDUCTOR DR.	SANTA CLARA, CA 95051
31918	IEE/SCHADOW INC.	8081 WALLACE ROAD	EDEN PRAIRIE, MN 55343
32997	BOURNS, INC., TRIMPOT PRODUCTS DIV.	1200 COLUMBIA AVE.	RIVERSIDE, CA 92507
50157	MIDWEST COMPONENTS INC.	P. O. BOX 787 1981 PORT CITY BLVD.	MUSKEGON, MI 49443
50434	HEWLETT-PACKARD COMPANY	640 PAGE MILL ROAD	PALO ALTO, CA 94304
51642	CENTRE ENGINEERING INC.	2820 E COLLEGE AVENUE	STATE COLLEGE, PA 16801
51984	NEC AMERICA INC. RADIO AND TRANSMISSION DIV.	2990 TELESTAR CT. SUITE 212	FALLS CHURCH, VA 22042
53184	XCITON CORPORATION	5 HEMLOCK STREET	LATHAM, NY 12110
54473	MATSUSHITA ELECTRIC, CORP. OF AMERICA	1 PANASONIC WAY	SECAUCUS, NJ 07094
54937	DEYOUNG MFG., INC.	PO BOX 1806, 1517 130TH AVE.	BELLEVUE, WA 98009
55680	NICHICON/AMERICA/CORP.	6435 N PROESEL AVENUE	CHICAGO, IL 60645
56289	SPRAGUE ELECTRIC CO.	87 MARSHALL ST.	NORTH ADAMS, MA 01247
57668	R-OHM CORP.	16931 MILLIKEN AVE.	IRVINE, CA 92713
59660	TUSONIX INC.	2155 N FORBES BLVD	TUCSON, AZ 85705
71279	CAMBRIDGE THERMIONIC CORP.	445 CONCORD AVE.	CAMBRIDGE, MA 02138
71400	BUSSMAN MFG., DIVISION OF MCGRAW-EDISON CO.	2536 W. UNIVERSITY ST.	ST. LOUIS, MO 63107
71590	CENTRALAB ELECTRONICS, DIV. OF GLOBE-UNION, INC.	P O BOX 858	FORT DODGE, IA 50501

CROSS INDEX—MFR. CODE NUMBER TO MANUFACTURER

Mfr. Code	Manufacturer	Address	City, State, Zip
72982	ERIE TECHNOLOGICAL PRODUCTS, INC.	644 W. 12TH ST.	ERIE, PA 16512
73138	BECKMAN INSTRUMENTS, INC., HELIPOT DIV.	2500 HARBOR BLVD.	FULLERTON, CA 92634
73899	JFD ELECTRONICS COMPONENTS CORP.	PINETREE ROAD	OXFORD, NC 27565
75042	TRW ELECTRONIC COMPONENTS, IRC FIXED RESISTORS, PHILADELPHIA DIVISION	401 N. BROAD ST.	PHILADELPHIA, PA 19108
77820	BENDIX CORP., THE, ELECTRICAL COMPONENTS DIVISION	SHERMAN AVE.	SIDNEY, NY 13838
80009	TEKTRONIX, INC.	P O BOX 500	BEAVERTON, OR 97077
80031	ELECTRA-MIDLAND CORP., MEPCO DIV.	22 COLUMBIA ROAD	MORRISTOWN, NJ 07960
82389	SWITCHCRAFT, INC.	5555 N. ELSTON AVE.	CHICAGO, IL 60630
90201	MALLORY CAPACITOR CO., DIV. OF P. R. MALLORY AND CO., INC.	3029 E. WASHINGTON STREET P. O. BOX 372	INDIANAPOLIS, IN 46206
91637	DALE ELECTRONICS, INC.	P. O. BOX 609	COLUMBUS, NE 68601
CODE 96	733 NOT FOUND		
91637	DALE ELECTRONICS, INC.	P. O. BOX 609	COLUMBUS, NE 68601

# Replaceable Electrical Parts—2235 Service

Component No.	Tektronix Part No.	Serial/Model No. Eff Dscnt	Name & Description	Mfr Code	Mfr Part Number
A1	670-7614-00		CKT BOARD ASSY:MAIN	80009	670-7614-00
A	672-1064-00		CKT BOARD ASSY:ATTENUATOR/TIMING,W/SHIELD	80009	672-1064-00
A2	670-7561-00		CKT BOARD ASSY:ATTENUATOR	80009	670-7561-00
A3	670-7611-00		CKT BOARD ASSY:FRONT PANEL	80009	670-7611-00
A4	670-7613-00		CKT BOARD ASSY:TIMING	80009	670-7613-00
A5	670-7612-00		CKT BOARD ASSY:ALTERNATE SWEEP	80009	670-7612-00
A6	670-7615-00		CKT BOARD ASSY:EMI FILTER BD	80009	670-7615-00
A1	670-7614-00		CKT BOARD ASSY:MAIN	80009	670-7614-00
A1C114	281-0767-00		CAP.,FXD,CER DI:330PF,20%,100V	12969	CGB331MEX
A1C115	281-0767-00		CAP.,FXD,CER DI:330PF,20%,100V	12969	CGB331MEX
A1C116	281-0862-00		CAP.,FXD,CER DI:0.001UF,+80-20%,100V	20932	401-ES-100AD102Z
A1C125	281-0772-00		CAP.,FXD,CER DI:0.0047UF,10%,100V	04222	GC701C472K
A1C126	283-0114-00		CAP.,FXD,CER DI:0.0015UF,5%,200V	59660	805534Y5DO152J
A1C130	283-0159-00		CAP.,FXD,CER DI:18PF,5%,50V	51642	T150-050NP0180J
A1C133	281-0785-00		CAP.,FXD,CER DI:68PF,10%,100V	72982	8035D2AADCOG680K
A1C164	281-0767-00		CAP.,FXD,CER DI:330PF,20%,100V	12969	CGB331MEX
A1C165	281-0767-00		CAP.,FXD,CER DI:330PF,20%,100V	12969	CGB331MEX
A1C175	281-0772-00		CAP.,FXD,CER DI:0.0047UF,10%,100V	04222	GC701C472K
A1C176	283-0114-00		CAP.,FXD,CER DI:0.0015UF,5%,200V	59660	805534Y5DO152J
A1C180	281-0140-00		CAP.,VAR,CER DI:5-25PF,100V	59660	518-023A 5-25
A1C198	281-0862-00		CAP.,FXD,CER DI:0.001UF,+80-20%,100V	20932	401-ES-100AD102Z
A1C200	290-0136-00		CAP.,FXD,ELCTLT:2.2UF,20%,20V	56289	162D225X0020CD2
A1C201	290-0136-00		CAP.,FXD,ELCTLT:2.2UF,20%,20V	56289	162D225X0020CD2
A1C210	281-0500-00		CAP.,FXD,CER DI:2.2PF,+/-0.5PF,500V	04222	7001-COJ-2R2D
A1C215	281-0862-00		CAP.,FXD,CER DI:0.001UF,+80-20%,100V	20932	401-ES-100AD102Z
A1C220	281-0772-00		CAP.,FXD,CER DI:0.0047UF,10%,100V	04222	GC701C472K
A1C225	281-0862-00		CAP.,FXD,CER DI:0.001UF,+80-20%,100V	20932	401-ES-100AD102Z
A1C226	281-0862-00		CAP.,FXD,CER DI:0.001UF,+80-20%,100V	20932	401-ES-100AD102Z
A1C228	283-0665-00		CAP.,FXD,MICA D:190PF,1%,100V	00853	D155F191F0
A1C229	283-0665-00		CAP.,FXD,MICA D:190PF,1%,100V	00853	D155F191F0
A1C237	281-0140-00		CAP.,VAR,CER DI:5-25PF,100V	59660	518-023A 5-25
A1C239	281-0776-00		CAP.,FXD,CER DI:120PF,5%,100V	04222	SR211A121JAA
A1C240	281-0511-00		CAP.,FXD,CER DI:22PF,+/-2.2PF,500V	59660	301-000C0G0220K
A1C241	281-0777-00		CAP.,FXD,CER DI:51PF,5%,100V	04222	SR211A510JAA
A1C242	281-0812-00		CAP.,FXD,CER DI:1000PF,10%,100V	72982	8035D9AADX7R102K
A1C250	281-0768-00		CAP.,FXD,CER DI:470PF,20%,100V	72982	8035D9AADW5R471M
A1C251	281-0768-00		CAP.,FXD,CER DI:470PF,20%,100V	72982	8035D9AADW5R471M
A1C255	281-0862-00		CAP.,FXD,CER DI:0.001UF,+80-20%,100V	20932	401-ES-100AD102Z
A1C262	281-0862-00		CAP.,FXD,CER DI:0.001UF,+80-20%,100V	20932	401-ES-100AD102Z
A1C274	281-0773-00		CAP.,FXD,CER DI:0.01UF,10%,100V	04222	SA201C103KAA
A1C281	281-0775-00		CAP.,FXD,CER DI:0.1UF,20%,50V	04222	MA205E104MAA
A1C292	290-0776-00		CAP.,FXD,ELCTLT:22UF,+50-10%,10V	55680	ULA1A220TEA
A1C312	281-0893-00		CAP.,FXD,CER DI:4.7PF,+/-0.5PF,100V	04222	MA101A4R7DAA
A1C337	281-0893-00		CAP.,FXD,CER DI:4.7PF,+/-0.5PF,100V	04222	MA101A4R7DAA
A1C363	281-0862-00		CAP.,FXD,CER DI:0.001UF,+80-20%,100V	20932	401-ES-100AD102Z
A1C369	281-0862-00		CAP.,FXD,CER DI:0.001UF,+80-20%,100V	20932	401-ES-100AD102Z
A1C381	283-0663-00		CAP.,FXD,MICA D:16.8PF,+/-0.5PF,500V	00853	D155C16R8D0
A1C389	281-0773-00		CAP.,FXD,CER DI:0.01UF,10%,100V	04222	SA201C103KAA
A1C390	281-0862-00		CAP.,FXD,CER DI:0.001UF,+80-20%,100V	20932	401-ES-100AD102Z
A1C392	281-0862-00		CAP.,FXD,CER DI:0.001UF,+80-20%,100V	20932	401-ES-100AD102Z
A1C396	283-0203-00		CAP.,FXD,CER DI:0.47UF,20%,50V	72982	8131M058Z5U0474M
A1C397	281-0773-00		CAP.,FXD,CER DI:0.01UF,10%,100V	04222	SA201C103KAA

Replaceable Electrical Parts—2235 Service

Component No.	Tektronix Part No.	Serial/Model No. Eff Dscont	Name & Description	Mfr Code	Mfr Part Number
A1C405	281-0773-00		CAP.,FXD,CER DI:0.01UF,10%,100V	04222	SA201C103KAA
A1C408	281-0773-00		CAP.,FXD,CER DI:0.01UF,10%,100V	04222	SA201C103KAA
A1C414	290-0246-00		CAP.,FXD,ELCTLT:3.3UF,10%,15V	56289	162D335X9015CD2
A1C415	290-0246-00		CAP.,FXD,ELCTLT:3.3UF,10%,15V	56289	162D335X9015CD2
A1C418	281-0862-00		CAP.,FXD,CER DI:0.001UF,+80-20%,100V	20932	401-ES-100AD102Z
A1C419	281-0851-00		CAP.,FXD,CER DI:180PF,5%,100VDC	20932	401E0100AD181J
A1C420	281-0773-00		CAP.,FXD,CER DI:0.01UF,10%,100V	04222	SA201C103KAA
A1C421	281-0773-00		CAP.,FXD,CER DI:0.01UF,10%,100V	04222	SA201C103KAA
A1C451	281-0772-00		CAP.,FXD,CER DI:0.0047UF,10%,100V	04222	GC701C472K
A1C453	281-0862-00		CAP.,FXD,CER DI:0.001UF,+80-20%,100V	20932	401-ES-100AD102Z
A1C459	281-0862-00		CAP.,FXD,CER DI:0.001UF,+80-20%,100V	20932	401-ES-100AD102Z
A1C473	281-0862-00		CAP.,FXD,CER DI:0.001UF,+80-20%,100V	20932	401-ES-100AD102Z
A1C479	281-0893-00		CAP.,FXD,CER DI:4.7PF,+/-0.5PF,100V	04222	MA101A4R7DAA
A1C480	281-0772-00		CAP.,FXD,CER DI:0.0047UF,10%,100V	04222	GC701C472K
A1C494	281-0773-00		CAP.,FXD,CER DI:0.01UF,10%,100V	04222	SA201C103KAA
A1C499	281-0773-00		CAP.,FXD,CER DI:0.01UF,10%,100V	04222	SA201C103KAA
A1C501	290-0246-00		CAP.,FXD,ELCTLT:3.3UF,10%,15V	56289	162D335X9015CD2
A1C502	281-0773-00		CAP.,FXD,CER DI:0.01UF,10%,100V	04222	SA201C103KAA
A1C503	281-0775-00		CAP.,FXD,CER DI:0.1UF,20%,50V	04222	MA205E104MAA
A1C504	290-0246-00		CAP.,FXD,ELCTLT:3.3UF,10%,15V	56289	162D335X9015CD2
A1C505	290-0183-00		CAP.,FXD,ELCTLT:1UF,10%,35V	90201	TAC105K035P02
A1C506	281-0772-00		CAP.,FXD,CER DI:0.0047UF,10%,100V	04222	GC701C472K
A1C507	290-0776-00		CAP.,FXD,ELCTLT:22UF,+50-10%,10V	55680	ULA1A220TEA
A1C517	281-0772-00		CAP.,FXD,CER DI:0.0047UF,10%,100V	04222	GC701C472K
A1C518	281-0852-00		CAP.,FXD,CER DI:1800PF,10%,100VDC	04222	GC101C182KAA
A1C519	281-0775-00		CAP.,FXD,CER DI:0.1UF,20%,50V	04222	MA205E104MAA
A1C520	290-0246-00		CAP.,FXD,ELCTLT:3.3UF,10%,15V	56289	162D335X9015CD2
A1C525	281-0895-00		CAP.,FXD,CER DI:6.8PF,100W VDC	04222	MA101A6R8DAA
A1C527	281-0797-00		CAP.,FXD,CER DI:15PF,10%,100V	72982	8035D9AADC0G150K
A1C531	281-0773-00		CAP.,FXD,CER DI:0.01UF,10%,100V	04222	SA201C103KAA
A1C537	281-0775-00		CAP.,FXD,CER DI:0.1UF,20%,50V	04222	MA205E104MAA
A1C538	281-0862-00		CAP.,FXD,CER DI:0.001UF,+80-20%,100V	20932	401-ES-100AD102Z
A1C539	281-0862-00		CAP.,FXD,CER DI:0.001UF,+80-20%,100V	20932	401-ES-100AD102Z
A1C540	290-0776-00		CAP.,FXD,ELCTLT:22UF,+50-10%,10V	55680	ULA1A220TEA
A1C545	283-0119-00		CAP.,FXD,CER DI:2200PF,5%,200V	59660	855-536Y5E0222J
A1C547	281-0767-00		CAP.,FXD,CER DI:330PF,20%,100V	12969	CGB331MEX
A1C553	281-0775-00		CAP.,FXD,CER DI:0.1UF,20%,50V	04222	MA205E104MAA
A1C561	281-0862-00		CAP.,FXD,CER DI:0.001UF,+80-20%,100V	20932	401-ES-100AD102Z
A1C565	281-0768-00		CAP.,FXD,CER DI:470PF,20%,100V	72982	8035D9AADW5R471M
A1C590	290-0136-00		CAP.,FXD,ELCTLT:2.2UF,20%,20V	56289	162D225X0020CD2
A1C603	281-0862-00		CAP.,FXD,CER DI:0.001UF,+80-20%,100V	20932	401-ES-100AD102Z
A1C635	281-0826-00		CAP.,FXD,CER DI:2200PF,5%,100V	12969	CGC222KEX
A1C646	290-0776-00		CAP.,FXD,ELCTLT:22UF,+50-10%,10V	55680	ULA1A220TEA
A1C647	281-0862-00		CAP.,FXD,CER DI:0.001UF,+80-20%,100V	20932	401-ES-100AD102Z
A1C648	281-0862-00		CAP.,FXD,CER DI:0.001UF,+80-20%,100V	20932	401-ES-100AD102Z
A1C649	281-0862-00		CAP.,FXD,CER DI:0.001UF,+80-20%,100V	20932	401-ES-100AD102Z
A1C673	281-0797-00		CAP.,FXD,CER DI:15PF,10%,100V	72982	8035D9AADC0G150K
A1C762	281-0811-00		CAP.,FXD,CER DI:10PF,10%,100V	72982	8035D2AADC1G100K
A1C764	281-0773-00		CAP.,FXD,CER DI:0.01UF,10%,100V	04222	SA201C103KAA
A1C770	281-0775-00		CAP.,FXD,CER DI:0.1UF,20%,50V	04222	MA205E104MAA
A1C775	281-0214-00		CAP.,VAR,CER DI:0.5-3PF,400V	80031	2502A0R503VP02F0
A1C777	281-0771-00		CAP.,FXD,CER DI:0.0022UF,20%,200V	56289	292C Z5U222M200B
A1C779	285-1101-00		CAP.,FXD,PLSTC:0.022UF,10%,200V	19396	223K02PT485
A1C780	281-0775-00		CAP.,FXD,CER DI:0.1UF,20%,50V	04222	MA205E104MAA

# Replaceable Electrical Parts—2235 Service

Component No.	Tektronix Part No.	Serial/Model No. Eff Dscnt	Name & Description	Mfr Code	Mfr Part Number
A1C782	281-0775-00		CAP.,FXD,CER DI:0.1UF,20%,50V	04222	MA205E104MAA
A1C785	281-0661-00		CAP.,FXD,CER DI:0.8PF,+/-0.1PF,500V	04222	7001-COK-OR8B
A1C787	281-0771-00		CAP.,FXD,CER DI:0.0022UF,20%,200V	56289	292C Z5U222M200B
A1C789	285-1101-00		CAP.,FXD,PLSTC:0.022UF,10%,200V	19396	223K02PT485
A1C796	281-0775-00		CAP.,FXD,CER DI:0.1UF,20%,50V	04222	MA205E104MAA
A1C797	281-0775-00		CAP.,FXD,CER DI:0.1UF,20%,50V	04222	MA205E104MAA
A1C799	283-0057-00		CAP.,FXD,CER DI:0.1UF,+80-20%,200V	56289	2C20Z5U104Z200B
A1C824	281-0785-00		CAP.,FXD,CER DI:68PF,10%,100V	72982	8035D2AADCOG680K
A1C825	281-0767-00		CAP.,FXD,CER DI:330PF,20%,100V	12969	CGB331MEX
A1C828	281-0775-00		CAP.,FXD,CER DI:0.1UF,20%,50V	04222	MA205E104MAA
A1C832	281-0775-00		CAP.,FXD,CER DI:0.1UF,20%,50V	04222	MA205E104MAA
A1C835	281-0775-00		CAP.,FXD,CER DI:0.1UF,20%,50V	04222	MA205E104MAA
A1C845	281-0771-00		CAP.,FXD,CER DI:0.0022UF,20%,200V	56289	292C Z5U222M200B
A1C847	283-0057-00		CAP.,FXD,CER DI:0.1UF,+80-20%,200V	56289	2C20Z5U104Z200B
A1C849	283-0057-00		CAP.,FXD,CER DI:0.1UF,+80-20%,200V	56289	2C20Z5U104Z200B
A1C851	283-0057-00		CAP.,FXD,CER DI:0.1UF,+80-20%,200V	56289	2C20Z5U104Z200B
A1C853	281-0791-00		CAP.,FXD,CER DI:270PF,10%,100V	72982	8035D2AADX5R271K
A1C854	283-0279-00		CAP.,FXD,CER DI:0.001UF,20%,3000V	59660	878-530 Y5S0102M
A1C855	285-1255-00		CAP.,FXD,PLASTIC:0.01UF,20%,3KV	56289	430P582
A1C871	283-0057-00		CAP.,FXD,CER DI:0.1UF,+80-20%,200V	56289	2C20Z5U104Z200B
A1C873	281-0775-00		CAP.,FXD,CER DI:0.1UF,20%,50V	04222	MA205E104MAA
A1C875	281-0775-00		CAP.,FXD,CER DI:0.1UF,20%,50V	04222	MA205E104MAA
A1C877	281-0775-00		CAP.,FXD,CER DI:0.1UF,20%,50V	04222	MA205E104MAA
A1C879	283-0057-00		CAP.,FXD,CER DI:0.1UF,+80-20%,200V	56289	2C20Z5U104Z200B
A1C893	283-0279-00		CAP.,FXD,CER DI:0.001UF,20%,3000V	59660	878-530 Y5S0102M
A1C904	285-1192-00		CAP.,FXD,PPR DI:0.0022UF,20%,250VAC	000FG	PME271Y422
A1C906	290-0978-00		CAP.,FXD,ELCTLT:75UF,+50-10%,450V	56289	17D1149
A1C907	285-0932-00		CAP.,FXD,PLSTC:1UF,10%,400V	14752	230B1E105K
A1C908	283-0481-00		CAP.,FXD,CER DI:220PF,10%,250 VAC	000LD	RK0611
A1C917	281-0812-00		CAP.,FXD,CER DI:1000PF,10%,100V	72982	8035D9AADX7R102K
A1C919	281-0852-00		CAP.,FXD,CER DI:1800PF,10%,100VDC	04222	GC101C182KAA.
A1C922	281-0775-00		CAP.,FXD,CER DI:0.1UF,20%,50V	04222	MA205E104MAA
A1C925	290-0973-00		CAP.,FXD,ELCTLT:100UF,20%,25 VDC	55680	ULB1E101M
A1C940	290-0922-00		CAP.,FXD,ELCTLT:1000UF,+50-10%,50V	55680	ULB1E102TFAANA
A1C941	283-0423-00		CAP.,FXD,CER DI:0.22UF,+80-20%,50V	04222	DG015E224Z
A1C942	290-0768-00		CAP.,FXD,ELCTLT:10UF,+50-10%,100V	54473	ECE-A100V10L
A1C943	290-0768-00		CAP.,FXD,ELCTLT:10UF,+50-10%,100V	54473	ECE-A100V10L
A1C944	290-0183-00		CAP.,FXD,ELCTLT:1UF,10%,35V	90201	TAC105K035P02
A1C945	281-0775-00		CAP.,FXD,CER DI:0.1UF,20%,50V	04222	MA205E104MAA
A1C954	290-0947-00		CAP.,FXD,ELCTLT:33UF,+50-10%,160V	55680	UHC2C330TFA
A1C956	290-0946-00		CAP.,FXD,ELCTLT:270UF,10+100%,40V	90201	VPR271N040E1E1C
A1C960	290-0945-00		CAP.,FXD,ELCTLT:840UF,10+100%,12V	90201	VPR841N012E1E1C
A1C961	290-0945-00		CAP.,FXD,ELCTLT:840UF,10+100%,12V	90201	VPR841N012E1E1C
A1C962	290-0945-00		CAP.,FXD,ELCTLT:840UF,10+100%,12V	90201	VPR841N012E1E1C
A1C963	290-0945-00		CAP.,FXD,ELCTLT:840UF,10+100%,12V	90201	VPR841N012E1E1C
A1C968	290-0945-00		CAP.,FXD,ELCTLT:840UF,10+100%,12V	90201	VPR841N012E1E1C
A1C970	290-0945-00		CAP.,FXD,ELCTLT:840UF,10+100%,12V	90201	VPR841N012E1E1C
A1C975	285-1255-00		CAP.,FXD,PLASTIC:0.01UF,20%,3KV	56289	430P582
A1C976	285-1255-00		CAP.,FXD,PLASTIC:0.01UF,20%,3KV	56289	430P582
A1C979	285-1255-00		CAP.,FXD,PLASTIC:0.01UF,20%,3KV	56289	430P582
A1C9272	281-0534-00		CAP.,FXD,CER DI:3.3PF,+/-0.25PF,500V	04222	7001-COJ-3R3C
A1C9273	281-0534-00		CAP.,FXD,CER DI:3.3PF,+/-0.25PF,500V	04222	7001-COJ-3R3C
A1CR133	152-0141-02		SEMICONV DEVICE:SILICON,30V,150MA	01295	1N4152R
A1CR183	152-0141-02		SEMICONV DEVICE:SILICON,30V,150MA	01295	1N4152R

Component No.	Tektronix Part No.	Serial/Model No. Eff Dscont	Name & Description	Mfr Code	Mfr Part Number
A1CR200	152-0141-02		SEMICON D DEVICE:SILICON,30V,150MA	01295	1N4152R
A1CR201	152-0141-02		SEMICON D DEVICE:SILICON,30V,150MA	01295	1N4152R
A1CR202	152-0141-02		SEMICON D DEVICE:SILICON,30V,150MA	01295	1N4152R
A1CR203	152-0141-02		SEMICON D DEVICE:SILICON,30V,150MA	01295	1N4152R
A1CR226	152-0141-02		SEMICON D DEVICE:SILICON,30V,150MA	01295	1N4152R
A1CR227	152-0141-02		SEMICON D DEVICE:SILICON,30V,150MA	01295	1N4152R
A1CR228	152-0141-02		SEMICON D DEVICE:SILICON,30V,150MA	01295	1N4152R
A1CR229	152-0141-02		SEMICON D DEVICE:SILICON,30V,150MA	01295	1N4152R
A1CR372	152-0141-02		SEMICON D DEVICE:SILICON,30V,150MA	01295	1N4152R
A1CR381	152-0141-02		SEMICON D DEVICE:SILICON,30V,150MA	01295	1N4152R
A1CR393	152-0141-02		SEMICON D DEVICE:SILICON,30V,150MA	01295	1N4152R
A1CR399	152-0141-02		SEMICON D DEVICE:SILICON,30V,150MA	01295	1N4152R
A1CR414	152-0141-02		SEMICON D DEVICE:SILICON,30V,150MA	01295	1N4152R
A1CR415	152-0141-02		SEMICON D DEVICE:SILICON,30V,150MA	01295	1N4152R
A1CR503	152-0075-00		SEMICON D DEVICE:GE,25V,40MA	14433	G866
A1CR508	152-0141-02		SEMICON D DEVICE:SILICON,30V,150MA	01295	1N4152R
A1CR509	152-0141-02		SEMICON D DEVICE:SILICON,30V,150MA	01295	1N4152R
A1CR514	152-0141-02		SEMICON D DEVICE:SILICON,30V,150MA	01295	1N4152R
A1CR518	152-0141-02		SEMICON D DEVICE:SILICON,30V,150MA	01295	1N4152R
A1CR551	152-0141-02		SEMICON D DEVICE:SILICON,30V,150MA	01295	1N4152R
A1CR556	152-0141-02		SEMICON D DEVICE:SILICON,30V,150MA	01295	1N4152R
A1CR583	152-0141-02		SEMICON D DEVICE:SILICON,30V,150MA	01295	1N4152R
A1CR712	152-0141-02		SEMICON D DEVICE:SILICON,30V,150MA	01295	1N4152R
A1CR764	152-0141-02		SEMICON D DEVICE:SILICON,30V,150MA	01295	1N4152R
A1CR765	152-0141-02		SEMICON D DEVICE:SILICON,30V,150MA	01295	1N4152R
A1CR768	152-0141-02		SEMICON D DEVICE:SILICON,30V,150MA	01295	1N4152R
A1CR770	152-0141-02		SEMICON D DEVICE:SILICON,30V,150MA	01295	1N4152R
A1CR780	152-0141-02		SEMICON D DEVICE:SILICON,30V,150MA	01295	1N4152R
A1CR805	152-0141-02		SEMICON D DEVICE:SILICON,30V,150MA	01295	1N4152R
A1CR818	152-0141-02		SEMICON D DEVICE:SILICON,30V,150MA	01295	1N4152R
A1CR820	152-0141-02		SEMICON D DEVICE:SILICON,30V,150MA	01295	1N4152R
A1CR823	152-0141-02		SEMICON D DEVICE:SILICON,30V,150MA	01295	1N4152R
A1CR824	152-0141-02		SEMICON D DEVICE:SILICON,30V,150MA	01295	1N4152R
A1CR825	152-0141-02		SEMICON D DEVICE:SILICON,30V,150MA	01295	1N4152R
A1CR829	152-0141-02		SEMICON D DEVICE:SILICON,30V,150MA	01295	1N4152R
A1CR840	152-0141-02		SEMICON D DEVICE:SILICON,30V,150MA	01295	1N4152R
A1CR845	152-0141-02		SEMICON D DEVICE:SILICON,30V,150MA	01295	1N4152R
A1CR851	152-0242-00		SEMICON D DEVICE:SILICON,225V,200MA	07263	FDH5004
A1CR853	152-0242-00		SEMICON D DEVICE:SILICON,225V,200MA	07263	FDH5004
A1CR854	152-0242-00		SEMICON D DEVICE:SILICON,225V,200MA	07263	FDH5004
A1CR855	152-0242-00		SEMICON D DEVICE:SILICON,225V,200MA	07263	FDH5004
A1CR879	152-0413-00		SEMICON D DEVICE:SILICON,400V,750MA	12969	UTR307
A1CR901	152-0040-00		SEMICON D DEVICE:SILICON,600V,1A	15238	LG109
A1CR902	152-0040-00		SEMICON D DEVICE:SILICON,600V,1A	15238	LG109
A1CR903	152-0040-00		SEMICON D DEVICE:SILICON,600V,1A	15238	LG109
A1CR904	152-0040-00		SEMICON D DEVICE:SILICON,600V,1A	15238	LG109
A1CR907	152-0808-00		SEMICON D DEVICE,DI:RECTIFIER,SI,400V,1.0A	01281	DSR3400X
A1CR908	152-0141-02		SEMICON D DEVICE:SILICON,30V,150MA	01295	1N4152R
A1CR920	152-0061-00		SEMICON D DEVICE:SILICON,175V,100MA	07263	FDH2161
A1CR945	152-0141-02		SEMICON D DEVICE:SILICON,30V,150MA	01295	1N4152R
A1CR946	152-0414-00		SEMICON D DEVICE:SILICON,200V,0.75A	12969	UTR308
A1CR947	152-0414-00		SEMICON D DEVICE:SILICON,200V,0.75A	12969	UTR308
A1CR954	152-0413-00		SEMICON D DEVICE:SILICON,400V,750MA	12969	UTR307
A1CR955	152-0413-00		SEMICON D DEVICE:SILICON,400V,750MA	12969	UTR307

# Replaceable Electrical Parts—2235 Service

Component No.	Tektronix Part No.	Serial/Model No. Eff Dscont	Name & Description	Mfr Code	Mfr Part Number
A1CR956	152-0414-00		SEMICONV DEVICE:SILICON,200V,0.75A	12969	UTR308
A1CR957	152-0414-00		SEMICONV DEVICE:SILICON,200V,0.75A	12969	UTR308
A1CR960	152-0414-00		SEMICONV DEVICE:SILICON,200V,0.75A	12969	UTR308
A1CR961	152-0414-00		SEMICONV DEVICE:SILICON,200V,0.75A	12969	UTR308
A1CR962	152-0414-00		SEMICONV DEVICE:SILICON,200V,0.75A	12969	UTR308
A1CR963	152-0414-00		SEMICONV DEVICE:SILICON,200V,0.75A	12969	UTR308
A1CR967	152-0581-00		SEMICONV DEVICE:SILICON,20V,1A	04713	1N5817
A1CR970	152-0581-00		SEMICONV DEVICE:SILICON,20V,1A	04713	1N5817
A1DS856	150-0035-00		LAMP,GLOW:90V,0.3MA,AID-T,WIRE LD	000LI	JH005/3011JA
A1DS858	150-0035-00		LAMP,GLOW:90V,0.3MA,AID-T,WIRE LD	000LI	JH005/3011JA
A1DS870	150-0035-00		LAMP,GLOW:90V,0.3MA,AID-T,WIRE LD	000LI	JH005/3011JA
A1DS9150	150-1071-00		LT EMITTING DIO:GREEN,565NM,20MA MAX	50434	QLMP-3531
A1E200	276-0532-00		SHIELDING BEAD,:	02114	56-590-65/4A6
A1E201	276-0532-00		SHIELDING BEAD,:	02114	56-590-65/4A6
A1E272	276-0532-00		SHIELDING BEAD,:	02114	56-590-65/4A6
A1E590	276-0752-00		CORE,EM:FERRITE	000LC	BP53-BH3.TX10
A1E907	276-0635-00		CORE,EM:TOROID,FERRITE	08057	7J-41405-TC
A1L142	108-0420-00		COIL,RF:60NH	80009	108-0420-00
A1L143	108-0420-00		COIL,RF:60NH	80009	108-0420-00
A1L192	108-0420-00		COIL,RF:60NH	80009	108-0420-00
A1L193	108-0420-00		COIL,RF:60NH	80009	108-0420-00
A1L960	108-1058-00		COIL,RF:FIXED,10UH	02113	B8724
A1L961	108-1058-00		COIL,RF:FIXED,10UH	02113	B8724
A1Q102	151-0712-00		TRANSISTOR:SILICON,NPN	04713	SPS8223
A1Q103	151-0712-00		TRANSISTOR:SILICON,NPN	04713	SPS8223
A1Q114	151-0190-00		TRANSISTOR:SILICON,NPN	07263	S032677
A1Q115	151-0190-00		TRANSISTOR:SILICON,NPN	07263	S032677
A1Q152	151-0712-00		TRANSISTOR:SILICON,NPN	04713	SPS8223
A1Q153	151-0712-00		TRANSISTOR:SILICON,NPN	04713	SPS8223
A1Q164	151-0190-00		TRANSISTOR:SILICON,NPN	07263	S032677
A1Q165	151-0190-00		TRANSISTOR:SILICON,NPN	07263	S032677
A1Q202	151-0212-00		TRANSISTOR:SILICON,NPN	04713	SRF 518
A1Q203	151-0212-00		TRANSISTOR:SILICON,NPN	04713	SRF 518
A1Q206	151-0369-00		TRANSISTOR:SILICON,PNP	01295	SKA6664
A1Q207	151-0369-00		TRANSISTOR:SILICON,PNP	01295	SKA6664
A1Q230	151-0271-00		TRANSISTOR:SILICON,PNP	04713	SPS8236
A1Q231	151-0271-00		TRANSISTOR:SILICON,PNP	04713	SPS8236
A1Q254	151-0752-00		TRANSISTOR:SILICON,NPN	01281	LT4403
A1Q255	151-0752-00		TRANSISTOR:SILICON,NPN	01281	LT4403
A1Q256	151-0752-00		TRANSISTOR:SILICON,NPN	01281	LT4403
A1Q257	151-0752-00		TRANSISTOR:SILICON,NPN	01281	LT4403
A1Q283	151-0736-00		TRANSISTOR:SILICON,NPN	04713	SPS8317
A1Q284	151-0712-00		TRANSISTOR:SILICON,NPN	04713	SPS8223
A1Q285	151-0712-00		TRANSISTOR:SILICON,NPN	04713	SPS8223
A1Q302	151-0711-01		TRANSISTOR:NPN,SI	04713	SPS8608M
A1Q303	151-0711-01		TRANSISTOR:NPN,SI	04713	SPS8608M
A1Q327	151-0711-01		TRANSISTOR:NPN,SI	04713	SPS8608M
A1Q328	151-0711-01		TRANSISTOR:NPN,SI	04713	SPS8608M
A1Q382	151-1042-00		SEMICONV DVC SE:MATCHED PAIR FET	01295	SKA5390
A1Q384	151-0711-00		TRANSISTOR:SILICON,NPN	04713	SPS8224
A1Q397	151-0190-00		TRANSISTOR:SILICON,NPN	07263	S032677
A1Q402	151-0276-00		TRANSISTOR:SILICON,PNP	80009	151-0276-00
A1Q403	151-0276-00		TRANSISTOR:SILICON,PNP	80009	151-0276-00
A1Q413	151-0190-00		TRANSISTOR:SILICON,NPN	07263	S032677

Replaceable Electrical Parts—2235 Service

Component No.	Tektronix Part No.	Serial/Model No. Eff Dscnt	Name & Description	Mfr Code	Mfr Part Number
A1Q419	151-0711-00		TRANSISTOR:SILICON,NPN	04713	SPS8224
A1Q420	151-0711-00		TRANSISTOR:SILICON,NPN	04713	SPS8224
A1Q421	151-0712-00		TRANSISTOR:SILICON,NPN	04713	SPS8223
A1Q422	151-0199-00		TRANSISTOR:SILICON,PNP	04713	SPS6866K
A1Q423	151-0424-00		TRANSISTOR:SILICON,NPN	04713	SPS8246
A1Q428	151-0711-00		TRANSISTOR:SILICON,NPN	04713	SPS8224
A1Q429	151-0712-00		TRANSISTOR:SILICON,NPN	04713	SPS8223
A1Q440	151-0711-00		TRANSISTOR:SILICON,NPN	04713	SPS8224
A1Q441	151-0711-00		TRANSISTOR:SILICON,NPN	04713	SPS8224
A1Q460	151-0712-00		TRANSISTOR:SILICON,NPN	04713	SPS8223
A1Q463	151-0712-00		TRANSISTOR:SILICON,NPN	04713	SPS8223
A1Q509	151-0188-00		TRANSISTOR:SILICON,PNP	04713	SPS6868K
A1Q511	151-0188-00		TRANSISTOR:SILICON,PNP	04713	SPS6868K
A1Q525	151-0190-00		TRANSISTOR:SILICON,NPN	07263	S032677
A1Q576	151-0199-00		TRANSISTOR:SILICON,PNP	04713	SPS6866K
A1Q578	151-0199-00		TRANSISTOR:SILICON,PNP	04713	SPS6866K
A1Q586	151-0198-00		TRANSISTOR:SILICON,NPN,SEL FROM MPS918	04713	SPS8802-1
A1Q756	151-0190-00		TRANSISTOR:SILICON,NPN	07263	S032677
A1Q770	151-0188-00		TRANSISTOR:SILICON,PNP	04713	SPS6868K
A1Q775	151-0347-00		TRANSISTOR:SILICON,NPN	56289	2N5551
A1Q779	151-0350-00		TRANSISTOR:SILICON,PNP	04713	SPS6700
A1Q780	151-0190-00		TRANSISTOR:SILICON,NPN	07263	S032677
A1Q785	151-0347-00		TRANSISTOR:SILICON,NPN	56289	2N5551
A1Q789	151-0350-00		TRANSISTOR:SILICON,PNP	04713	SPS6700
A1Q804	151-0188-00		TRANSISTOR:SILICON,PNP	04713	SPS6868K
A1Q814	151-0188-00		TRANSISTOR:SILICON,PNP	04713	SPS6868K
A1Q825	151-0424-00		TRANSISTOR:SILICON,NPN	04713	SPS8246
A1Q829	151-0199-00		TRANSISTOR:SILICON,PNP	04713	SPS6866K
A1Q835	151-0199-00		TRANSISTOR:SILICON,PNP	04713	SPS6866K
A1Q840	151-0347-00		TRANSISTOR:SILICON,NPN	56289	2N5551
A1Q845	151-0350-00		TRANSISTOR:SILICON,PNP	04713	SPS6700
A1Q885	151-0443-00		TRANSISTOR:SILICON,PNP	04713	SPS7950
A1Q908	151-0164-00		TRANSISTOR:SILICON,PNP	01295	SKB3334
A1Q928	151-0432-00		TRANSISTOR:SILICON,NPN	27014	T07391E2
A1Q930	151-0164-00		TRANSISTOR:SILICON,PNP	01295	SKB3334
A1Q935	151-0506-00		SCR:SILICON	03508	C106B2X283
A1Q938	151-0276-00		TRANSISTOR:SILICON,PNP	80009	151-0276-00
A1Q939	151-0276-00		TRANSISTOR:SILICON,PNP	80009	151-0276-00
A1Q944	151-0432-00		TRANSISTOR:SILICON,NPN	27014	T07391E2
A1Q946	151-0476-02		TRANSISTOR:SILICON,NPN,SEL	04713	OB
A1Q947	151-0476-02		TRANSISTOR:SILICON,NPN,SEL	04713	OB
A1Q9070	151-1151-00		TRANSISTOR:N-CHANNEL,SI	04713	MPT3N40
A1R100	315-0430-00		RES.,FXD,CMPSN:43 OHM,5%,0.25W	01121	CB4305
A1R101	315-0430-00		RES.,FXD,CMPSN:43 OHM,5%,0.25W	01121	CB4305
A1R102	321-0155-00		RES.,FXD,FILM:402 OHM,1%,0.125W	91637	MFF1816G402R0F
A1R103	321-0155-00		RES.,FXD,FILM:402 OHM,1%,0.125W	91637	MFF1816G402R0F
A1R104	321-0101-00		RES.,FXD,FILM:110 OHM,1%,0.125W	91637	MFF1816G110R0F
A1R105	321-0101-00		RES.,FXD,FILM:110 OHM,1%,0.125W	91637	MFF1816G110R0F
A1R106	321-0161-00		RES.,FXD,FILM:464 OHM,1%,0.125W	91637	MFF1816G464R0F
A1R108	321-0223-00		RES.,FXD,FILM:2.05K OHM,1%,0.125W	91637	MFF1816G20500F
A1R109	321-0221-00		RES.,FXD,FILM:1.96K OHM,1%,0.125W	91637	MFF1816G19600F
A1R114	321-0225-00		RES.,FXD,FILM:2.15K OHM,1%,0.125W	91637	MFF1816G21500F
A1R115	321-0225-00		RES.,FXD,FILM:2.15K OHM,1%,0.125W	91637	MFF1816G21500F
A1R120	321-0123-00		RES.,FXD,FILM:187 OHM,1%,0.125W	91637	MFF1816G187R0F

## Replaceable Electrical Parts—2235 Service

Component No.	Tektronix Part No.	Serial/Model No. Eff Dscnt	Name & Description	Mfr Code	Mfr Part Number
A1R121	321-0123-00		RES.,FXD,FILM:187 OHM,1%,0.125W	91637	MFF1816G187R0F
A1R122	315-0750-00		RES.,FXD,CMPSN:75 OHM,5%,0.25W	01121	CB7505
A1R125	315-0242-00		RES.,FXD,CMPSN:2.4K OHM,5%,0.25W	01121	CB2425
A1R126	315-0182-00		RES.,FXD,CMPSN:1.8K OHM,5%,0.25W	01121	CB1825
A1R130	315-0510-00		RES.,FXD,CMPSN:51 OHM,5%,0.25W	01121	CB5105
A1R131	315-0510-00		RES.,FXD,CMPSN:51 OHM,5%,0.25W	01121	CB5105
A1R132	315-0511-00		RES.,FXD,CMPSN:510 OHM,5%,0.25W	01121	CB5115
A1R133	315-0111-00		RES.,FXD,CMPSN:110 OHM,5%,0.25W	01121	CB1115
A1R135	315-0101-00		RES.,FXD,CMPSN:100 OHM,5%,0.25W	01121	CB1015
A1R136	315-0101-00		RES.,FXD,CMPSN:100 OHM,5%,0.25W	01121	CB1015
A1R138	315-0182-00		RES.,FXD,CMPSN:1.8K OHM,5%,0.25W	01121	CB1825
A1R139	315-0302-00		RES.,FXD,CMPSN:3K OHM,5%,0.25W	01121	CB3025
A1R142	315-0101-00		RES.,FXD,CMPSN:100 OHM,5%,0.25W	01121	CB1015
A1R143	315-0101-00		RES.,FXD,CMPSN:100 OHM,5%,0.25W	01121	CB1015
A1R144	315-0511-00		RES.,FXD,CMPSN:510 OHM,5%,0.25W	01121	CB5115
A1R145	311-1238-00		RES.,VAR,NONWIR:5K OHM,10%,0.50W	73138	72-27-0
A1R150	315-0430-00		RES.,FXD,CMPSN:43 OHM,5%,0.25W	01121	CB4305
A1R151	315-0430-00		RES.,FXD,CMPSN:43 OHM,5%,0.25W	01121	CB4305
A1R152	321-0155-00		RES.,FXD,FILM:402 OHM,1%,0.125W	91637	MFF1816G402R0F
A1R153	321-0155-00		RES.,FXD,FILM:402 OHM,1%,0.125W	91637	MFF1816G402R0F
A1R154	321-0101-00		RES.,FXD,FILM:110 OHM,1%,0.125W	91637	MFF1816G110R0F
A1R155	321-0101-00		RES.,FXD,FILM:110 OHM,1%,0.125W	91637	MFF1816G110R0F
A1R156	321-0161-00		RES.,FXD,FILM:464 OHM,1%,0.125W	91637	MFF1816G464R0F
A1R158	321-0223-00		RES.,FXD,FILM:2.05K OHM,1%,0.125W	91637	MFF1816G20500F
A1R159	321-0221-00		RES.,FXD,FILM:1.96K OHM,1%,0.125W	91637	MFF1816G19600F
A1R164	321-0225-00		RES.,FXD,FILM:2.15K OHM,1%,0.125W	91637	MFF1816G21500F
A1R165	321-0225-00		RES.,FXD,FILM:2.15K OHM,1%,0.125W	91637	MFF1816G21500F
A1R170	321-0123-00		RES.,FXD,FILM:187 OHM,1%,0.125W	91637	MFF1816G187R0F
A1R171	321-0123-00		RES.,FXD,FILM:187 OHM,1%,0.125W	91637	MFF1816G187R0F
A1R172	315-0750-00		RES.,FXD,CMPSN:75 OHM,5%,0.25W	01121	CB7505
A1R175	315-0242-00		RES.,FXD,CMPSN:2.4K OHM,5%,0.25W	01121	CB2425
A1R176	315-0182-00		RES.,FXD,CMPSN:1.8K OHM,5%,0.25W	01121	CB1825
A1R180	315-0510-00		RES.,FXD,CMPSN:51 OHM,5%,0.25W	01121	CB5105
A1R181	315-0510-00		RES.,FXD,CMPSN:51 OHM,5%,0.25W	01121	CB5105
A1R182	315-0511-00		RES.,FXD,CMPSN:510 OHM,5%,0.25W	01121	CB5115
A1R183	315-0111-00		RES.,FXD,CMPSN:110 OHM,5%,0.25W	01121	CB1115
A1R185	315-0101-00		RES.,FXD,CMPSN:100 OHM,5%,0.25W	01121	CB1015
A1R186	315-0101-00		RES.,FXD,CMPSN:100 OHM,5%,0.25W	01121	CB1015
A1R188	315-0182-00		RES.,FXD,CMPSN:1.8K OHM,5%,0.25W	01121	CB1825
A1R189	315-0302-00		RES.,FXD,CMPSN:3K OHM,5%,0.25W	01121	CB3025
A1R192	315-0101-00		RES.,FXD,CMPSN:100 OHM,5%,0.25W	01121	CB1015
A1R193	315-0101-00		RES.,FXD,CMPSN:100 OHM,5%,0.25W	01121	CB1015
A1R194	315-0511-00		RES.,FXD,CMPSN:510 OHM,5%,0.25W	01121	CB5115
A1R195	311-1238-00		RES.,VAR,NONWIR:5K OHM,10%,0.50W	73138	72-27-0
A1R200	315-0911-00		RES.,FXD,CMPSN:910 OHM,5%,0.25W	01121	CB9115
A1R202	321-0178-00		RES.,FXD,FILM:698 OHM,1%,0.125W	91637	MFF1816G698R0F
A1R203	321-0178-00		RES.,FXD,FILM:698 OHM,1%,0.125W	91637	MFF1816G698R0F
A1R204	321-0089-00		RES.,FXD,FILM:82.5 OHM,1%,0.125W	91637	MFF1816G82R50F
A1R206	321-0139-00		RES.,FXD,FILM:274 OHM,1%,0.125W	91637	MFF1816G274R0F
A1R207	321-0139-00		RES.,FXD,FILM:274 OHM,1%,0.125W	91637	MFF1816G274R0F
A1R210	315-0431-00		RES.,FXD,CMPSN:430 OHM,5%,0.25W	01121	CB4315
A1R212	321-0086-00		RES.,FXD,FILM:76.8 OHM,1%,0.125W	91637	MFF1816G76R80F
A1R213	321-0086-00		RES.,FXD,FILM:76.8 OHM,1%,0.125W	91637	MFF1816G76R80F
A1R215	321-0135-00		RES.,FXD,FILM:249 OHM,1%,0.125W	91637	MFF1816G249R0F

## Replaceable Electrical Parts—2235 Service

Component No.	Tektronix Part No.	Serial/Model No. Eff      Dscont	Name & Description	Mfr Code	Mfr Part Number
A1R216	321-0163-00		RES.,FXD,FILM:487 OHM,1%,0.125W	91637	MFF1816G487R0F
A1R217	321-0163-00		RES.,FXD,FILM:487 OHM,1%,0.125W	91637	MFF1816G487R0F
A1R218	321-0102-00		RES.,FXD,FILM:113 OHM,1%,0.125W	91637	MFF1816G113R0F
A1R219	321-0102-00		RES.,FXD,FILM:113 OHM,1%,0.125W	91637	MFF1816G113R0F
A1R220	307-0104-00		RES.,FXD,CMPSN:3.3 OHM,5%,0.25W	01121	CB33G5
A1R222	321-0318-00		RES.,FXD,FILM:20K OHM,1%,0.125W	91637	MFF1816G20001F
A1R223	321-0318-00		RES.,FXD,FILM:20K OHM,1%,0.125W	91637	MFF1816G20001F
A1R225	315-0103-00		RES.,FXD,CMPSN:10K OHM,5%,0.25W	01121	CB1035
A1R226	315-0221-00		RES.,FXD,CMPSN:220 OHM,5%,0.25W	01121	CB2215
A1R227	315-0221-00		RES.,FXD,CMPSN:220 OHM,5%,0.25W	01121	CB2215
A1R230	321-0086-00		RES.,FXD,FILM:76.8 OHM,1%,0.125W	91637	MFF1816G76R80F
A1R231	321-0086-00		RES.,FXD,FILM:76.8 OHM,1%,0.125W	91637	MFF1816G76R80F
A1R233	321-0085-00		RES.,FXD,FILM:75 OHM,1%,0.125W	91637	MFF1816G75R00F
A1R234	315-0360-00		RES.,FXD,CMPSN:36 OHM,5%,0.25W	01121	CB3605
A1R235	315-0360-00		RES.,FXD,CMPSN:36 OHM,5%,0.25W	01121	CB3605
A1R236	315-0751-00		RES.,FXD,CMPSN:750 OHM,5%,0.25W	01121	CB7515
A1R239	315-0242-00		RES.,FXD,CMPSN:2.4K OHM,5%,0.25W	01121	CB2425
A1R240	311-1248-00		RES.,VAR,NONWIR:500 OHM,10%,0.50W	73138	72-23-0
A1R241	311-1237-00		RES.,VAR,NONWIR:1K OHM,10%,0.50W	32997	3386X-T07-102
A1R242	315-0273-00		RES.,FXD,CMPSN:27K OHM,5%,0.25W	01121	CB2735
A1R244	321-0172-00		RES.,FXD,FILM:604 OHM,1%,0.125W	91637	MFF1816G604R0F
A1R245	321-0172-00		RES.,FXD,FILM:604 OHM,1%,0.125W	91637	MFF1816G604R0F
A1R250	315-0221-00		RES.,FXD,CMPSN:220 OHM,5%,0.25W	01121	CB2215
A1R251	315-0221-00		RES.,FXD,CMPSN:220 OHM,5%,0.25W	01121	CB2215
A1R254	321-0110-00		RES.,FXD,FILM:137 OHM,1%,0.125W	91637	MFF1816G137R0F
A1R255	321-0110-00		RES.,FXD,FILM:137 OHM,1%,0.125W	91637	MFF1816G137R0F
A1R256	322-0175-00		RES.,FXD,FILM:649 OHM,1%,0.25W	75042	CEBT0-6490F
A1R257	322-0175-00		RES.,FXD,FILM:649 OHM,1%,0.25W	75042	CEBT0-6490F
A1R258	322-0180-00		RES.,FXD,FILM:732 OHM,1%,0.25W	75042	CEBT0-7320F
A1R259	322-0180-00		RES.,FXD,FILM:732 OHM,1%,0.25W	75042	CEBT0-7320F
A1R261	323-0058-00		RES.,FXD,FILM:39.2 OHM,1%,0.5W	91637	CMF65-116GB9R20F
A1R262	315-0151-00		RES.,FXD,CMPSN:150 OHM,5%,0.25W	01121	CB1515
A1R266	323-0114-00		RES.,FXD,FILM:150 OHM,1%,0.50W	75042	CECT0-1500F
A1R267	323-0114-00		RES.,FXD,FILM:150 OHM,1%,0.50W	75042	CECT0-1500F
A1R268	323-0114-00		RES.,FXD,FILM:150 OHM,1%,0.50W	75042	CECT0-1500F
A1R269	323-0114-00		RES.,FXD,FILM:150 OHM,1%,0.50W	75042	CECT0-1500F
A1R270	323-0114-00		RES.,FXD,FILM:150 OHM,1%,0.50W	75042	CECT0-1500F
A1R271	323-0114-00		RES.,FXD,FILM:150 OHM,1%,0.50W	75042	CECT0-1500F
A1R279	315-0223-00		RES.,FXD,CMPSN:22K OHM,5%,0.25W	01121	CB2235
A1R281	315-0821-00		RES.,FXD,CMPSN:820 OHM,5%,0.25W	01121	CB8215
A1R282	315-0752-00		RES.,FXD,CMPSN:7.5K OHM,5%,0.25W	01121	CB7525
A1R283	315-0471-00		RES.,FXD,CMPSN:470 OHM,5%,0.25W	01121	CB4715
A1R284	315-0621-00		RES.,FXD,CMPSN:620 OHM,5%,0.25W	01121	CB6215
A1R285	315-0561-00		RES.,FXD,CMPSN:560 OHM,5%,0.25W	01121	CB5615
A1R286	321-0068-00		RES.,FXD,FILM:49.9 OHM,1%,0.125W	91637	MFF1816G49R90F
A1R287	321-0068-00		RES.,FXD,FILM:49.9 OHM,1%,0.125W	91637	MFF1816G49R90F
A1R288	315-0431-00		RES.,FXD,CMPSN:430 OHM,5%,0.25W	01121	CB4315
A1R289	315-0431-00		RES.,FXD,CMPSN:430 OHM,5%,0.25W	01121	CB4315
A1R292	321-0179-00		RES.,FXD,FILM:715 OHM,1%,0.125W	91637	MFF1816G715R0F
A1R293	315-0620-00		RES.,FXD,CMPSN:62 OHM,5%,0.25W	01121	CB6205
A1R301	315-0221-00		RES.,FXD,CMPSN:220 OHM,5%,0.25W	01121	CB2215
A1R302	315-0221-00		RES.,FXD,CMPSN:220 OHM,5%,0.25W	01121	CB2215
A1R303	315-0221-00		RES.,FXD,CMPSN:220 OHM,5%,0.25W	01121	CB2215
A1R304	315-0152-00		RES.,FXD,CMPSN:1.5K OHM,5%,0.25W	01121	CB1525

Replaceable Electrical Parts—2235 Service

Component No.	Tektronix Part No.	Serial/Model No. Eff Dscnt	Name & Description	Mfr Code	Mfr Part Number
A1R305	315-0152-00		RES.,FXD,CMPSN:1.5K OHM,5%,0.25W	01121	CB1525
A1R306	315-0470-00		RES.,FXD,CMPSN:47 OHM,5%,0.25W	01121	CB4705
A1R307	315-0470-00		RES.,FXD,CMPSN:47 OHM,5%,0.25W	01121	CB4705
A1R309	311-1564-00		RES.,VAR,NONWIR:TRMR,500 OHM,0.5W	73138	91-86-0
A1R310	321-0194-00		RES.,FXD,FILM:1.02K OHM,1%,0.125W	91637	MFF1816G10200F
A1R311	321-0194-00		RES.,FXD,FILM:1.02K OHM,1%,0.125W	91637	MFF1816G10200F
A1R312	321-0098-00		RES.,FXD,FILM:102 OHM,1%,0.125W	91637	MFF1816G102R0F
A1R314	321-0170-00		RES.,FXD,FILM:576 OHM,1%,0.125W	91637	MFF1816G576R0F
A1R315	321-0170-00		RES.,FXD,FILM:576 OHM,1%,0.125W	91637	MFF1816G576R0F
A1R317	321-0209-00		RES.,FXD,FILM:1.47K OHM,1%,0.125W	91637	MFF1816G14700F
A1R318	321-0198-00		RES.,FXD,FILM:1.13K OHM,1%,0.125W	91637	MFF1816G11300F
A1R319	321-0213-00		RES.,FXD,FILM:1.62K OHM,1%,0.125W	91637	MFF1816G16200F
A1R321	321-0208-00		RES.,FXD,FILM:1.43K OHM,1%,0.125W	91637	MFF1816G14300F
A1R322	321-0241-00		RES.,FXD,FILM:3.16K OHM,1%,0.125W	91637	MFF1816G31600F
A1R324	315-0101-00		RES.,FXD,CMPSN:100 OHM,5%,0.25W	01121	CB1015
A1R326	315-0221-00		RES.,FXD,CMPSN:220 OHM,5%,0.25W	01121	CB2215
A1R327	315-0221-00		RES.,FXD,CMPSN:220 OHM,5%,0.25W	01121	CB2215
A1R328	315-0221-00		RES.,FXD,CMPSN:220 OHM,5%,0.25W	01121	CB2215
A1R329	315-0152-00		RES.,FXD,CMPSN:1.5K OHM,5%,0.25W	01121	CB1525
A1R330	315-0152-00		RES.,FXD,CMPSN:1.5K OHM,5%,0.25W	01121	CB1525
A1R331	315-0470-00		RES.,FXD,CMPSN:47 OHM,5%,0.25W	01121	CB4705
A1R332	315-0470-00		RES.,FXD,CMPSN:47 OHM,5%,0.25W	01121	CB4705
A1R335	321-0203-00		RES.,FXD,FILM:1.27K OHM,1%,0.125W	91637	MFF1816G12700F
A1R336	321-0203-00		RES.,FXD,FILM:1.27K OHM,1%,0.125W	91637	MFF1816G12700F
A1R337	321-0098-00		RES.,FXD,FILM:102 OHM,1%,0.125W	91637	MFF1816G102R0F
A1R339	321-0170-00		RES.,FXD,FILM:576 OHM,1%,0.125W	91637	MFF1816G576R0F
A1R340	321-0170-00		RES.,FXD,FILM:576 OHM,1%,0.125W	91637	MFF1816G576R0F
A1R342	321-0209-00		RES.,FXD,FILM:1.47K OHM,1%,0.125W	91637	MFF1816G14700F
A1R343	321-0198-00		RES.,FXD,FILM:1.13K OHM,1%,0.125W	91637	MFF1816G11300F
A1R344	321-0213-00		RES.,FXD,FILM:1.62K OHM,1%,0.125W	91637	MFF1816G16200F
A1R346	321-0208-00		RES.,FXD,FILM:1.43K OHM,1%,0.125W	91637	MFF1816G14300F
A1R347	321-0241-00		RES.,FXD,FILM:3.16K OHM,1%,0.125W	91637	MFF1816G31600F
A1R349	315-0101-00		RES.,FXD,CMPSN:100 OHM,5%,0.25W	01121	CB1015
A1R350	315-0470-00		RES.,FXD,CMPSN:47 OHM,5%,0.25W	01121	CB4705
A1R351	315-0470-00		RES.,FXD,CMPSN:47 OHM,5%,0.25W	01121	CB4705
A1R352	321-0275-00		RES.,FXD,FILM:7.15K OHM,1%,0.125W	91637	MFF1816G71500F
A1R353	321-0275-00		RES.,FXD,FILM:7.15K OHM,1%,0.125W	91637	MFF1816G71500F
A1R356	315-0622-00		RES.,FXD,CMPSN:6.2K OHM,5%,0.25W	01121	CB6225
A1R357	321-0149-00		RES.,FXD,FILM:348 OHM,1%,0.125W	91637	MFF1816G348R0F
A1R358	315-0101-00		RES.,FXD,CMPSN:100 OHM,5%,0.25W	01121	CB1015
A1R359	321-0148-00		RES.,FXD,FILM:340 OHM,1%,0.125W	91637	MFF1816G340R0F
A1R360	321-0156-00		RES.,FXD,FILM:412 OHM,1%,0.125W	91637	MFF1816G412R0F
A1R361	315-0101-00		RES.,FXD,CMPSN:100 OHM,5%,0.25W	01121	CB1015
A1R363	315-0331-00		RES.,FXD,CMPSN:330 OHM,5%,0.25W	01121	CB3315
A1R365	315-0620-00		RES.,FXD,CMPSN:62 OHM,5%,0.25W	01121	CB6205
A1R366	315-0202-00		RES.,FXD,CMPSN:2K OHM,5%,0.25W	01121	CB2025
A1R367	315-0911-00		RES.,FXD,CMPSN:910 OHM,5%,0.25W	01121	CB9115
A1R369	315-0751-00		RES.,FXD,CMPSN:750 OHM,5%,0.25W	01121	CB7515
A1R372	315-0220-00		RES.,FXD,CMPSN:22 OHM,5%,0.25W	01121	CB2205
A1R374	315-0202-00		RES.,FXD,CMPSN:2K OHM,5%,0.25W	01121	CB2025
A1R381	321-0444-00		RES.,FXD,FILM:412K OHM,1%,0.125W	91637	MFF1816G41202F
A1R382	315-0470-00		RES.,FXD,CMPSN:47 OHM,5%,0.25W	01121	CB4705
A1R384	315-0121-00		RES.,FXD,CMPSN:120 OHM,5%,0.25W	01121	CB1215
A1R385	315-0130-00		RES.,FXD,CMPSN:13 OHM,5%,0.25W	01121	CB1305

## Replaceable Electrical Parts—2235 Service

Component No.	Tektronix Part No.	Serial/Model No. Eff      Dscnt	Name & Description	Mfr Code	Mfr Part Number
A1R386	315-0911-00		RES.,FXD,CMPSN:910 OHM,5%,0.25W	01121	CB9115
A1R389	315-0100-00		RES.,FXD,CMPSN:10 OHM,5%,0.25W	01121	CB1005
A1R390	315-0101-00		RES.,FXD,CMPSN:100 OHM,5%,0.25W	01121	CB1015
A1R392	315-0751-00		RES.,FXD,CMPSN:750 OHM,5%,0.25W	01121	CB7515
A1R393	315-0240-00		RES.,FXD,CMPSN:24 OHM,5%,0.25W	01121	CB2405
A1R395	315-0911-00		RES.,FXD,CMPSN:910 OHM,5%,0.25W	01121	CB9115
A1R397	315-0200-00		RES.,FXD,CMPSN:20 OHM,5%,0.25W	01121	CB2005
A1R398	315-0201-00		RES.,FXD,CMPSN:200 OHM,5%,0.25W	01121	CB2015
A1R399	315-0751-00		RES.,FXD,CMPSN:750 OHM,5%,0.25W	01121	CB7515
A1R402	315-0182-00		RES.,FXD,CMPSN:1.8K OHM,5%,0.25W	01121	CB1825
A1R405	315-0752-00		RES.,FXD,CMPSN:7.5K OHM,5%,0.25W	01121	CB7525
A1R407	315-0752-00		RES.,FXD,CMPSN:7.5K OHM,5%,0.25W	01121	CB7525
A1R408	315-0392-00		RES.,FXD,CMPSN:3.9K OHM,5%,0.25W	01121	CB3925
A1R411	315-0103-00		RES.,FXD,CMPSN:10K OHM,5%,0.25W	01121	CB1035
A1R412	315-0102-00		RES.,FXD,CMPSN:1K OHM,5%,0.25W	01121	CB1025
A1R413	315-0113-00		RES.,FXD,CMPSN:11K OHM,5%,0.25W	01121	CB1135
A1R414	315-0244-00		RES.,FXD,CMPSN:240K OHM,5%,0.25W	01121	CB2445
A1R415	315-0244-00		RES.,FXD,CMPSN:240K OHM,5%,0.25W	01121	CB2445
A1R416	315-0473-00		RES.,FXD,CMPSN:47K OHM,5%,0.25W	01121	CB4735
A1R417	315-0473-00		RES.,FXD,CMPSN:47K OHM,5%,0.25W	01121	CB4735
A1R419	315-0182-00		RES.,FXD,CMPSN:1.8K OHM,5%,0.25W	01121	CB1825
A1R420	315-0101-00		RES.,FXD,CMPSN:100 OHM,5%,0.25W	01121	CB1015
A1R421	315-0203-00		RES.,FXD,CMPSN:20K OHM,5%,0.25W	01121	CB2035
A1R422	315-0100-00		RES.,FXD,CMPSN:10 OHM,5%,0.25W	01121	CB1005
A1R423	315-0100-00		RES.,FXD,CMPSN:10 OHM,5%,0.25W	01121	CB1005
A1R424	315-0203-00		RES.,FXD,CMPSN:20K OHM,5%,0.25W	01121	CB2035
A1R426	315-0434-00		RES.,FXD,CMPSN:430K OHM,5%,0.25W	01121	CB4345
A1R427	315-0434-00		RES.,FXD,CMPSN:430K OHM,5%,0.25W	01121	CB4345
A1R428	315-0102-00		RES.,FXD,CMPSN:1K OHM,5%,0.25W	01121	CB1025
A1R429	315-0102-00		RES.,FXD,CMPSN:1K OHM,5%,0.25W	01121	CB1025
A1R432	315-0823-00		RES.,FXD,CMPSN:82K OHM,5%,0.25W	01121	CB8235
A1R433	315-0823-00		RES.,FXD,CMPSN:82K OHM,5%,0.25W	01121	CB8235
A1R434	311-1646-00		RES.,VAR,NONWIR:TRMR,2M OHM,0.5W	01121	E4A205
A1R435	311-1646-00		RES.,VAR,NONWIR:TRMR,2M OHM,0.5W	01121	E4A205
A1R440	315-0101-00		RES.,FXD,CMPSN:100 OHM,5%,0.25W	01121	CB1015
A1R441	315-0101-00		RES.,FXD,CMPSN:100 OHM,5%,0.25W	01121	CB1015
A1R442	321-0087-00		RES.,FXD,FILM:78.7 OHM,1%,0.125W	91637	MFF1816G78R70F
A1R443	321-0087-00		RES.,FXD,FILM:78.7 OHM,1%,0.125W	91637	MFF1816G78R70F
A1R444	315-0162-00		RES.,FXD,CMPSN:1.6K OHM,5%,0.25W	01121	CB1625
A1R446	315-0224-00		RES.,FXD,CMPSN:220K OHM,5%,0.25W	01121	CB2245
A1R448	315-0270-00		RES.,FXD,CMPSN:27 OHM,5%,0.25W	01121	CB2705
A1R449	315-0270-00		RES.,FXD,CMPSN:27 OHM,5%,0.25W	01121	CB2705
A1R451	315-0100-00		RES.,FXD,CMPSN:10 OHM,5%,0.25W	01121	CB1005
A1R452	315-0272-00		RES.,FXD,CMPSN:2.7K OHM,5%,0.25W	01121	CB2725
A1R453	315-0470-00		RES.,FXD,CMPSN:47 OHM,5%,0.25W	01121	CB4705
A1R455	315-0100-00		RES.,FXD,CMPSN:10 OHM,5%,0.25W	01121	CB1005
A1R457	321-0207-00		RES.,FXD,FILM:1.4K OHM,1%,0.125W	91637	MFF1816G14000F
A1R458	321-0197-00		RES.,FXD,FILM:1.1K OHM,1%,0.125W	91637	MFF1816G11000F
A1R459	315-0242-00		RES.,FXD,CMPSN:2.4K OHM,5%,0.25W	01121	CB2425
A1R460	321-0091-00		RES.,FXD,FILM:86.6 OHM,1%,0.125W	91637	MFF1816G86R60F
A1R461	321-0203-00		RES.,FXD,FILM:1.27K OHM,1%,0.125W	91637	MFF1816G12700F
A1R462	321-0201-00		RES.,FXD,FILM:1.21K OHM,1%,0.125W	91637	MFF1816G12100F
A1R463	321-0090-00		RES.,FXD,FILM:84.5 OHM,1%,0.125W	91637	MFF1816G84R50F
A1R464	315-0271-00		RES.,FXD,CMPSN:270 OHM,5%,0.25W	01121	CB2715

## Replaceable Electrical Parts—2235 Service

Component No.	Tektronix	Serial/Model No.		Name & Description	Mfr Code	Mfr Part Number
	Part No.	Eff	Dscont			
A1R465	315-0431-00			RES.,FXD,CMPSN:430 OHM,5%,0.25W	01121	CB4315
A1R469	315-0820-00			RES.,FXD,CMPSN:82 OHM,5%,0.25W	01121	CB8205
A1R470	315-0113-00			RES.,FXD,CMPSN:11K OHM,5%,0.25W	01121	CB1135
A1R471	311-1245-00			RES.,VAR,NONWIR:10K OHM,10%,0.50W	73138	72-28-0
A1R473	315-0392-00			RES.,FXD,CMPSN:3.9K OHM,5%,0.25W	01121	CB3925
A1R474	315-0432-00			RES.,FXD,CMPSN:4.3K OHM,5%,0.25W	01121	CB4325
A1R478	315-0222-00			RES.,FXD,CMPSN:2.2K OHM,5%,0.25W	01121	CB2225
A1R479	311-1236-00			RES.,VAR,NONWIR:250 OHM,10%,0.50W	73138	72-22-0
A1R483	315-0391-00			RES.,FXD,CMPSN:390 OHM,5%,0.25W	01121	CB3915
A1R486	315-0431-00			RES.,FXD,CMPSN:430 OHM,5%,0.25W	01121	CB4315
A1R487	315-0471-00			RES.,FXD,CMPSN:470 OHM,5%,0.25W	01121	CB4715
A1R494	307-0104-01			RES.,FXD,CMPSN:3.3 OHM,5%,0.25W	01121	CB33G5
A1R499	307-0104-01			RES.,FXD,CMPSN:3.3 OHM,5%,0.25W	01121	CB33G5
A1R501	315-0512-00			RES.,FXD,CMPSN:5.1K OHM,5%,0.25W	01121	CB5125
A1R502	315-0911-00			RES.,FXD,CMPSN:910 OHM,5%,0.25W	01121	CB9115
A1R503	315-0473-00			RES.,FXD,CMPSN:47K OHM,5%,0.25W	01121	CB4735
A1R504	315-0124-00			RES.,FXD,CMPSN:120K OHM,5%,0.25W	01121	CB1245
A1R505	315-0473-00			RES.,FXD,CMPSN:47K OHM,5%,0.25W	01121	CB4735
A1R507	315-0391-00			RES.,FXD,CMPSN:390 OHM,5%,0.25W	01121	CB3915
A1R509	315-0222-00			RES.,FXD,CMPSN:2.2K OHM,5%,0.25W	01121	CB2225
A1R510	315-0471-00			RES.,FXD,CMPSN:470 OHM,5%,0.25W	01121	CB4715
A1R511	315-0392-00			RES.,FXD,CMPSN:3.9K OHM,5%,0.25W	01121	CB3925
A1R512	315-0432-00			RES.,FXD,CMPSN:4.3K OHM,5%,0.25W	01121	CB4325
A1R513	315-0391-00			RES.,FXD,CMPSN:390 OHM,5%,0.25W	01121	CB3915
A1R514	315-0471-00			RES.,FXD,CMPSN:470 OHM,5%,0.25W	01121	CB4715
A1R516	315-0392-00			RES.,FXD,CMPSN:3.9K OHM,5%,0.25W	01121	CB3925
A1R517	315-0432-00			RES.,FXD,CMPSN:4.3K OHM,5%,0.25W	01121	CB4325
A1R518	315-0102-00			RES.,FXD,CMPSN:1K OHM,5%,0.25W	01121	CB1025
A1R523	315-0153-00			RES.,FXD,CMPSN:15K OHM,5%,0.25W	01121	CB1535
A1R524	321-0318-00			RES.,FXD,FILM:20K OHM,1%,0.125W	91637	MFF1816G20001F
A1R525	321-0322-00			RES.,FXD,FILM:22.1K OHM,1%,0.125W	91637	MFF1816G22101F
A1R526	315-0152-00			RES.,FXD,CMPSN:1.5K OHM,5%,0.25W	01121	CB1525
A1R527	315-0472-00			RES.,FXD,CMPSN:4.7K OHM,5%,0.25W	01121	CB4725
A1R528	315-0911-00			RES.,FXD,CMPSN:910 OHM,5%,0.25W	01121	CB9115
A1R538	315-0512-00			RES.,FXD,CMPSN:5.1K OHM,5%,0.25W	01121	CB5125
A1R539	315-0512-00			RES.,FXD,CMPSN:5.1K OHM,5%,0.25W	01121	CB5125
A1R540	315-0511-00			RES.,FXD,CMPSN:510 OHM,5%,0.25W	01121	CB5115
A1R541	315-0511-00			RES.,FXD,CMPSN:510 OHM,5%,0.25W	01121	CB5115
A1R544	315-0431-00			RES.,FXD,CMPSN:430 OHM,5%,0.25W	01121	CB4315
A1R545	315-0102-00			RES.,FXD,CMPSN:1K OHM,5%,0.25W	01121	CB1025
A1R547	315-0102-00			RES.,FXD,CMPSN:1K OHM,5%,0.25W	01121	CB1025
A1R548	315-0102-00			RES.,FXD,CMPSN:1K OHM,5%,0.25W	01121	CB1025
A1R549	315-0681-00			RES.,FXD,CMPSN:680 OHM,5%,0.25W	01121	CB6815
A1R555	315-0821-00			RES.,FXD,CMPSN:820 OHM,5%,0.25W	01121	CB8215
A1R556	315-0512-00			RES.,FXD,CMPSN:5.1K OHM,5%,0.25W	01121	CB5125
A1R558	315-0512-00			RES.,FXD,CMPSN:5.1K OHM,5%,0.25W	01121	CB5125
A1R560	315-0512-00			RES.,FXD,CMPSN:5.1K OHM,5%,0.25W	01121	CB5125
A1R561	315-0512-00			RES.,FXD,CMPSN:5.1K OHM,5%,0.25W	01121	CB5125
A1R562	315-0512-00			RES.,FXD,CMPSN:5.1K OHM,5%,0.25W	01121	CB5125
A1R564	315-0202-00			RES.,FXD,CMPSN:2K OHM,5%,0.25W	01121	CB2025
A1R565	315-0301-00			RES.,FXD,CMPSN:300 OHM,5%,0.25W	01121	CB3015
A1R566	315-0511-00			RES.,FXD,CMPSN:510 OHM,5%,0.25W	01121	CB5115
A1R568	315-0332-00			RES.,FXD,CMPSN:3.3K OHM,5%,0.25W	01121	CB3325
A1R569	315-0432-00			RES.,FXD,CMPSN:4.3K OHM,5%,0.25W	01121	CB4325

Replaceable Electrical Parts—2235 Service

Component No.	Tektronix Part No.	Serial/Model No. Eff Dscont	Name & Description	Mfr Code	Mfr Part Number
A1R571	315-0222-00		RES.,FXD,CMPSN:2.2K OHM,5%,0.25W	01121	CB2225
A1R572	315-0102-00		RES.,FXD,CMPSN:1K OHM,5%,0.25W	01121	CB1025
A1R573	315-0222-00		RES.,FXD,CMPSN:2.2K OHM,5%,0.25W	01121	CB2225
A1R574	315-0102-00		RES.,FXD,CMPSN:1K OHM,5%,0.25W	01121	CB1025
A1R576	315-0561-00		RES.,FXD,CMPSN:560 OHM,5%,0.25W	01121	CB5615
A1R577	315-0221-00		RES.,FXD,CMPSN:220 OHM,5%,0.25W	01121	CB2215
A1R578	315-0561-00		RES.,FXD,CMPSN:560 OHM,5%,0.25W	01121	CB5615
A1R580	315-0181-00		RES.,FXD,CMPSN:180 OHM,5%,0.25W	01121	CB1815
A1R586	315-0101-00		RES.,FXD,CMPSN:100 OHM,5%,0.25W	01121	CB1015
A1R645	315-0201-00		RES.,FXD,CMPSN:200 OHM,5%,0.25W	01121	CB2015
A1R646	311-1563-00		RES.,VAR,NONWIR:1K OHM,20%,0.50W	73138	91-85-0
A1R647	315-0102-00		RES.,FXD,CMPSN:1K OHM,5%,0.25W	01121	CB1025
A1R648	315-0512-00		RES.,FXD,CMPSN:5.1K OHM,5%,0.25W	01121	CB5125
A1R649	315-0512-00		RES.,FXD,CMPSN:5.1K OHM,5%,0.25W	01121	CB5125
A1R673	315-0472-00		RES.,FXD,CMPSN:4.7K OHM,5%,0.25W	01121	CB4725
A1R676	315-0471-00		RES.,FXD,CMPSN:470 OHM,5%,0.25W	01121	CB4715
A1R756	315-0912-00		RES.,FXD,CMPSN:9.1K OHM,5%,0.25W	01121	CB9125
A1R757	315-0202-00		RES.,FXD,CMPSN:2K OHM,5%,0.25W	01121	CB2025
A1R758	321-0343-00		RES.,FXD,FILM:36.5K OHM,1%,0.125W	91637	MFF1816G36501F
A1R759	321-0267-00		RES.,FXD,FILM:5.9K OHM,1%,0.125W	91637	MFF1816G59000F
A1R760	311-1565-00		RES.,VAR,NONWIR:250 OHM,20%,0.50W	73138	91-87-0
A1R761	321-0210-00		RES.,FXD,FILM:1.5K OHM,1%,0.125W	91637	MFF1816G15000F
A1R762	315-0153-00		RES.,FXD,CMPSN:15K OHM,5%,0.25W	01121	CB1535
A1R764	315-0221-00		RES.,FXD,CMPSN:220 OHM,5%,0.25W	01121	CB2215
A1R766	321-0109-00		RES.,FXD,FILM:133 OHM,1%,0.125W	91637	MFF1816G133R0F
A1R768	321-0158-00		RES.,FXD,FILM:432 OHM,1%,0.125W	91637	MFF1816G432R0F
A1R770	315-0470-00		RES.,FXD,CMPSN:47 OHM,5%,0.25W	01121	CB4705
A1R773	321-0182-00		RES.,FXD,FILM:768 OHM,1%,0.125W	91637	MFF1816G768R0F
A1R775	323-0310-00		RES.,FXD,FILM:16.5K OHM,1%,0.50W	75042	CECT0-1652F
A1R776	321-0205-00		RES.,FXD,FILM:1.33K OHM,1%,0.125W	91637	MFF1816G13300F
A1R777	315-0470-00		RES.,FXD,CMPSN:47 OHM,5%,0.25W	01121	CB4705
A1R778	315-0101-00		RES.,FXD,CMPSN:100 OHM,5%,0.25W	01121	CB1015
A1R779	315-0243-00		RES.,FXD,CMPSN:24K OHM,5%,0.25W	01121	CB2435
A1R780	315-0470-00		RES.,FXD,CMPSN:47 OHM,5%,0.25W	01121	CB4705
A1R782	321-0209-00		RES.,FXD,FILM:1.47K OHM,1%,0.125W	91637	MFF1816G14700F
A1R783	321-0201-00		RES.,FXD,FILM:1.21K OHM,1%,0.125W	91637	MFF1816G12100F
A1R785	323-0310-00		RES.,FXD,FILM:16.5K OHM,1%,0.50W	75042	CECT0-1652F
A1R786	321-0205-00		RES.,FXD,FILM:1.33K OHM,1%,0.125W	91637	MFF1816G13300F
A1R787	315-0470-00		RES.,FXD,CMPSN:47 OHM,5%,0.25W	01121	CB4705
A1R788	315-0101-00		RES.,FXD,CMPSN:100 OHM,5%,0.25W	01121	CB1015
A1R789	315-0243-00		RES.,FXD,CMPSN:24K OHM,5%,0.25W	01121	CB2435
A1R792	321-0263-00		RES.,FXD,FILM:5.36K OHM,1%,0.125W	91637	MFF1816G53600F
A1R793	321-0361-00		RES.,FXD,FILM:56.2K OHM,1%,0.125W	91637	MFF1816G56201F
A1R796	315-0100-00		RES.,FXD,CMPSN:10 OHM,5%,0.25W	01121	CB1005
A1R797	315-0100-00		RES.,FXD,CMPSN:10 OHM,5%,0.25W	01121	CB1005
A1R799	315-0100-00		RES.,FXD,CMPSN:10 OHM,5%,0.25W	01121	CB1005
A1R800	315-0682-00		RES.,FXD,CMPSN:6.8K OHM,5%,0.25W	01121	CB6825
A1R804	315-0102-00		RES.,FXD,CMPSN:1K OHM,5%,0.25W	01121	CB1025
A1R805	315-0562-00		RES.,FXD,CMPSN:5.6K OHM,5%,0.25W	01121	CB5625
A1R810	315-0682-00		RES.,FXD,CMPSN:6.8K OHM,5%,0.25W	01121	CB6825
A1R814	315-0102-00		RES.,FXD,CMPSN:1K OHM,5%,0.25W	01121	CB1025
A1R818	315-0302-00		RES.,FXD,CMPSN:3K OHM,5%,0.25W	01121	CB3025
A1R820	315-0332-00		RES.,FXD,CMPSN:3.3K OHM,5%,0.25W	01121	CB3325
A1R822	301-0512-00		RES.,FXD,CMPSN:5.1K OHM,5%,0.50W	01121	EB5125

## Replaceable Electrical Parts—2235 Service

Component No.	Tektronix Part No.	Serial/Model No. Eff Dscont	Name & Description	Mfr Code	Mfr Part Number
A1R823	301-0512-00		RES.,FXD,CMPSN:5.1K OHM,5%,0.50W	01121	EB5125
A1R825	315-0750-00		RES.,FXD,CMPSN:75 OHM,5%,0.25W	01121	CB7505
A1R826	315-0104-00		RES.,FXD,CMPSN:100K OHM,5%,0.25W	01121	CB1045
A1R828	315-0560-00		RES.,FXD,CMPSN:56 OHM,5%,0.25W	01121	CB5605
A1R830	321-0212-00		RES.,FXD,FILM:1.58K OHM,1%,0.125W	91637	MFF1816G15800F
A1R832	321-0222-00		RES.,FXD,FILM:2K OHM,1%,0.125W	91637	MFF1816G20000F
A1R834	315-0101-00		RES.,FXD,CMPSN:100 OHM,5%,0.25W	01121	CB1015
A1R835	321-0228-00		RES.,FXD,FILM:2.32K OHM,1%,0.125W	91637	MFF1816G23200F
A1R836	315-0102-00		RES.,FXD,CMPSN:1K OHM,5%,0.25W	01121	CB1025
A1R840	315-0561-00		RES.,FXD,CMPSN:560 OHM,5%,0.25W	01121	CB5615
A1R841	322-0322-00		RES.,FXD,FILM:22.1K OHM,1%,0.25W	24546	NA60D2212F
A1R842	315-0241-00		RES.,FXD,CMPSN:240 OHM,5%,0.25W	01121	CB2415
A1R844	315-0104-00		RES.,FXD,CMPSN:100K OHM,5%,0.25W	01121	CB1045
A1R845	315-0472-00		RES.,FXD,CMPSN:4.7K OHM,5%,0.25W	01121	CB4725
A1R849	315-0102-00		RES.,FXD,CMPSN:1K OHM,5%,0.25W	01121	CB1025
A1R851	311-1558-00		RES.,VAR,NONWIR:20K OHM,20%,0.50W	73138	91-80-0
A1R852	315-0203-00		RES.,FXD,CMPSN:20K OHM,5%,0.25W	01121	CB2035
A1R853	315-0244-00		RES.,FXD,CMPSN:240K OHM,5%,0.25W	01121	CB2445
A1R854	315-0472-00		RES.,FXD,CMPSN:4.7K OHM,5%,0.25W	01121	CB4725
A1R858	315-0511-00		RES.,FXD,CMPSN:510 OHM,5%,0.25W	01121	CB5115
A1R860	315-0625-00		RES.,FXD,CMPSN:6.2M OHM,5%,0.25W	01121	CB6255
A1R870	311-1555-00		RES.,VAR,NONWIR:100K OHM,20%,0.5W	73138	91-77-0
A1R871	315-0102-00		RES.,FXD,CMPSN:1K OHM,5%,0.25W	01121	CB1025
A1R872	315-0223-00		RES.,FXD,CMPSN:22K OHM,5%,0.25W	01121	CB2235
A1R873	315-0513-00		RES.,FXD,CMPSN:51K OHM,5%,0.25W	01121	CB5135
A1R874	311-1555-00		RES.,VAR,NONWIR:100K OHM,20%,0.5W	73138	91-77-0
A1R875	315-0102-00		RES.,FXD,CMPSN:1K OHM,5%,0.25W	01121	CB1025
A1R877	315-0102-00		RES.,FXD,CMPSN:1K OHM,5%,0.25W	01121	CB1025
A1R879	315-0514-00		RES.,FXD,CMPSN:510K OHM,5%,0.25W	01121	CB5145
A1R885	315-0912-00		RES.,FXD,CMPSN:9.1K OHM,5%,0.25W	01121	CB9125
A1R886	315-0184-00		RES.,FXD,CMPSN:180K OHM,5%,0.25W	01121	CB1845
A1R888	301-0514-00		RES.,FXD,CMPSN:510K OHM,5%,0.50W	01121	EB5145
A1R889	301-0514-00		RES.,FXD,CMPSN:510K OHM,5%,0.50W	01121	EB5145
A1R890	301-0514-00		RES.,FXD,CMPSN:510K OHM,5%,0.50W	01121	EB5145
A1R891	301-0514-00		RES.,FXD,CMPSN:510K OHM,5%,0.50W	01121	EB5145
A1R892	301-0514-00		RES.,FXD,CMPSN:510K OHM,5%,0.50W	01121	EB5145
A1R893	311-1933-00		RES.,VAR,NONWIR:PNL,5M OHM,10%,0.50W	01121	17M095
A1R894	301-0514-00		RES.,FXD,CMPSN:510K OHM,5%,0.50W	01121	EB5145
A1R905	301-0823-00		RES.,FXD,CMPSN:82K OHM,5%,0.50W	01121	EB8235
A1R906	301-0823-00		RES.,FXD,CMPSN:82K OHM,5%,0.50W	01121	EB8235
A1R907	308-0843-00		RES.,FXD WW:0.2 OHM,5%,1.0W	91637	RS1AR2000JT/R
A1R908	315-0302-00		RES.,FXD,CMPSN:3K OHM,5%,0.25W	01121	CB3025
A1R910	315-0301-00		RES.,FXD,CMPSN:300 OHM,5%,0.25W	01121	CB3015
A1R912	321-0150-00		RES.,FXD,FILM:357 OHM,1%,0.125W	91637	MFF1816G357R0F
A1R913	321-0289-00		RES.,FXD,FILM:10K OHM,1%,0.125W	91637	MFF1816G10001F
A1R914	321-0378-00		RES.,FXD,FILM:84.5K OHM,1%,0.125W	91637	MFF1816G84501F
A1R915	321-0289-00		RES.,FXD,FILM:10K OHM,1%,0.125W	91637	MFF1816G10001F
A1R916	315-0514-00		RES.,FXD,CMPSN:510K OHM,5%,0.25W	01121	CB5145
A1R917	315-0303-00		RES.,FXD,CMPSN:30K OHM,5%,0.25W	01121	CB3035
A1R919	315-0113-00		RES.,FXD,CMPSN:11K OHM,5%,0.25W	01121	CB1135
A1R921	315-0303-00		RES.,FXD,CMPSN:30K OHM,5%,0.25W	01121	CB3035
A1R922	315-0203-00		RES.,FXD,CMPSN:20K OHM,5%,0.25W	01121	CB2035
A1R925	315-0124-00		RES.,FXD,CMPSN:120K OHM,5%,0.25W	01121	CB1245
A1R926	303-0154-00		RES.,FXD,CMPSN:150K OHM,5%,1W	01121	GB1545

Replaceable Electrical Parts—2235 Service

Component No.	Tektronix Part No.	Serial/Model No. Eff	Dscont	Name & Description	Mfr Code	Mfr Part Number
A1R927	315-0104-00			RES.,FXD,CMPSN:100K OHM,5%,0.25W	01121	CB1045
A1R928	315-0682-00			RES.,FXD,CMPSN:6.8K OHM,5%,0.25W	01121	CB6825
A1R929	315-0302-00			RES.,FXD,CMPSN:3K OHM,5%,0.25W	01121	CB3025
A1R930	315-0104-00			RES.,FXD,CMPSN:100K OHM,5%,0.25W	01121	CB1045
A1R934	308-0441-00			RES.,FXD,WW:3 OHM,5%,3W	91637	CW2B-3R00J
A1R935	315-0121-00			RES.,FXD,CMPSN:120 OHM,5%,0.25W	01121	CB1215
A1R937	321-0234-00			RES.,FXD,FILM:2.67K OHM,1%,0.125W	91637	MFF1816G26700F
A1R938	311-1248-00			RES.,VAR,NONWIR:500 OHM,10%,0.50W	73138	72-23-0
A1R939	321-0304-00			RES.,FXD,FILM:14.3K OHM,1%,0.125W	91637	MFF1816G14301F
A1R940	315-0203-00			RES.,FXD,CMPSN:20K OHM,5%,0.25W	01121	CB2035
A1R941	315-0102-00			RES.,FXD,CMPSN:1K OHM,5%,0.25W	01121	CB1025
A1R942	315-0102-00			RES.,FXD,CMPSN:1K OHM,5%,0.25W	01121	CB1025
A1R943	301-0472-00			RES.,FXD,CMPSN:4.7K OHM,5%,0.50W	01121	EB4725
A1R944	315-0102-00			RES.,FXD,CMPSN:1K OHM,5%,0.25W	01121	CB1025
A1R945	301-0622-00			RES.,FXD,CMPSN:6.2K OHM,5%,0.50W	01121	EB6225
A1R946	315-0470-00			RES.,FXD,CMPSN:47 OHM,5%,0.25W	01121	CB4705
A1R947	315-0470-00			RES.,FXD,CMPSN:47 OHM,5%,0.25W	01121	CB4705
A1R949	308-0677-00			RES.,FXD,WW:1 OHM,5%,2W	75042	BWH-1R000J
A1R964	307-0106-00			RES.,FXD,CMPSN:4.7 OHM,5%,0.25W	01121	CB47G5
A1R966	307-0106-00			RES.,FXD,CMPSN:4.7 OHM,5%,0.25W	01121	CB47G5
A1R971	308-0847-00			RES.,FXD,WW:0.62 OHM,5%,1W	75042	BW20-0.62OHM
A1R976	315-0512-00			RES.,FXD,CMPSN:5.1K OHM,5%,0.25W	01121	CB5125
A1R978	315-0512-00			RES.,FXD,CMPSN:5.1K OHM,5%,0.25W	01121	CB5125
A1R9272	301-0121-00			RES.,FXD,CMPSN:120 OHM,5%,0.50W	01121	EB1215
A1R9273	301-0121-00			RES.,FXD,CMPSN:120 OHM,5%,0.50W	01121	EB1215
A1RT236	307-0125-00			RES.,THERMAL:500 OHM,10%,.25 DEG C	50157	2D1595
A1S901	260-1849-00			SWITCH,PUSH:DPDT,4A,250VAC,W/BRKT	31918	NE15/F2U103EE
A1T390	120-1401-00			XFMR,TRIG:	54937	OBD
A1T906	120-1439-00			TRANSFORMER,RF:ENERGY STORAGE	20462	OBD
A1T944	120-1347-00			TRANSFORMER,RF:DRIVER SATURATING POT CORE	80009	120-1347-00
A1T948	120-1348-00	B010100	B010379	XFMR,PWR,SDN&SU:HIGH VOLTAGE	80009	120-1348-00
A1T948	120-1348-01	B010380		XFMR,PWR,SDN&SU:HIGH VOLTAGE	80009	120-1348-01
A1TP940	131-0589-00			TERMINAL,PIN:0.46 L X 0.025 SQ	22526	48283-029
A1TP950	131-0589-00			TERMINAL,PIN:0.46 L X 0.025 SQ	22526	48283-029
A1U130	155-0274-00			MICROCIRCUIT,LI:VERTICAL PREAMP	80009	155-0274-00
A1U180	155-0274-00			MICROCIRCUIT,LI:VERTICAL PREAMP	80009	155-0274-00
A1U225	156-0067-00			MICROCIRCUIT,LI:OPERATIONAL AMPLIFIER	01295	MICROA741CP
A1U310	156-0534-00			MICROCIRCUIT,LI:DUAL DIFF AMPL,14 LD DIP	80009	156-0534-00
A1U335	156-0534-00			MICROCIRCUIT,LI:DUAL DIFF AMPL,14 LD DIP	80009	156-0534-00
A1U350	156-1294-00			MICROCIRCUIT,LI:FIVE NPN TRANSISTOR ARRAY	80009	156-1294-00
A1U426	156-0158-00			MICROCIRCUIT,LI:DUAL OPERATIONAL AMPLIFIER	18324	MC1458N
A1U460	156-0534-00			MICROCIRCUIT,LI:DUAL DIFF AMPL,14 LD DIP	80009	156-0534-00
A1U480	156-1641-00			MICROCIRCUIT,DI:ECL,QUAD 2-INPUT NOR GATE	80009	156-1641-00
A1U502	156-1713-00			MICROCIRCUIT,DI:ECL RETRIG MONOSTAGE	04713	MC10198
A1U504	156-1335-00			MICROCIRCUIT,DI:DUAL RETRIG RESET MONO MV	07263	96LS02
A1U506	156-1639-00			MICROCIRCUIT,DI:DUAL D MASTER SLAVE	04713	MC10H131
A1U532	156-1641-00			MICROCIRCUIT,DI:ECL,QUAD 2-INPUT NOR GATE	80009	156-1641-00
A1U537	156-0721-02			MICROCIRCUIT,DI:QUAD 2-IN NAND SCHMITT TRI	04713	SN74LS132NDS
A1U540	156-0388-03			MICROCIRCUIT,DI:DUAL D FLIP-FLOP	07263	74LS74A
A1U555	156-0728-02			MICROCIRCUIT,DI:QUAD 2 IPUT S TATE W/OC	80009	156-0728-02
A1U565	156-0384-02			MICROCIRCUIT,DI:QUAD 2-INP NAND GATE	01295	SN74LS03
A1U758	156-1149-00			MICROCIRCUIT,LI:OPERATIONAL AMP,JFET INPUT	27014	GLEA134
A1U930	156-1627-00			MICROCIRCUIT,LI:POWER WIDTH MODULATED CONT	01295	TL594CN
A1U975	152-0806-00			SEMICONV DEVICE:HV MULTIPLIER,4K VAC INPUT	12969	CMX647

## Replaceable Electrical Parts—2235 Service

Component No.	Tektronix Part No.	Serial/Model No. Eff Dscont	Name & Description	Mfr Code	Mfr Part Number
A1VR200	152-0149-00		SEMICONV DEVICE:ZENER,0.4W,10V,5%	04713	SZG35009K3
A1VR645	152-0317-00		SEMICONV DEVICE:ZENER,0.25W,6.2V,5%	04713	SZG20012
A1VR712	152-0508-00		SEMICONV DEVICE:ZENER,0.4W,12.6V,5%	80009	152-0508-00
A1VR764	152-0508-00		SEMICONV DEVICE:ZENER,0.4W,12.6V,5%	80009	152-0508-00
A1VR782	152-0243-00		SEMICONV DEVICE:ZENER,0.4W,15V,5%	14552	TD3810983
A1VR828	152-0514-00		SEMICONV DEVICE:ZENER,0.4W,10V,1%	80009	152-0514-00
A1VR925	152-0166-00		SEMICONV DEVICE:ZENER,0.4W,6.2V,5%	04713	SZ11738RL
A1VR935	152-0255-00		SEMICONV DEVICE:ZENER,0.4W,51V,5%	80009	152-0255-00
A1VR943	152-0317-00		SEMICONV DEVICE:ZENER,0.25W,6.2V,5%	04713	SZG20012
A1W282	131-0566-00		BUS CONDUCTOR:DUMMY RES,2.375,22 AWG	57668	JWW-0200E0
A1W283	131-0566-00		BUS CONDUCTOR:DUMMY RES,2.375,22 AWG	57668	JWW-0200E0
A1W310	131-0566-00		BUS CONDUCTOR:DUMMY RES,2.375,22 AWG	57668	JWW-0200E0
A1W335	131-0566-00		BUS CONDUCTOR:DUMMY RES,2.375,22 AWG	57668	JWW-0200E0
A1W350	131-0566-00		BUS CONDUCTOR:DUMMY RES,2.375,22 AWG	57668	JWW-0200E0
A1W351	131-0566-00		BUS CONDUCTOR:DUMMY RES,2.375,22 AWG	57668	JWW-0200E0
A1W408	131-0566-00		BUS CONDUCTOR:DUMMY RES,2.375,22 AWG	57668	JWW-0200E0
A1W410	131-0566-00		BUS CONDUCTOR:DUMMY RES,2.375,22 AWG	57668	JWW-0200E0
A1W419	131-0566-00		BUS CONDUCTOR:DUMMY RES,2.375,22 AWG	57668	JWW-0200E0
A1W428	131-0566-00		BUS CONDUCTOR:DUMMY RES,2.375,22 AWG	57668	JWW-0200E0
A1W429	131-0566-00		BUS CONDUCTOR:DUMMY RES,2.375,22 AWG	57668	JWW-0200E0
A1W494	131-0566-00		BUS CONDUCTOR:DUMMY RES,2.375,22 AWG	57668	JWW-0200E0
A1W535	131-0566-00		BUS CONDUCTOR:DUMMY RES,2.375,22 AWG	57668	JWW-0200E0
A1W537	131-0566-00		BUS CONDUCTOR:DUMMY RES,2.375,22 AWG	57668	JWW-0200E0
A1W538	131-0566-00		BUS CONDUCTOR:DUMMY RES,2.375,22 AWG	57668	JWW-0200E0
A1W555	131-0566-00		BUS CONDUCTOR:DUMMY RES,2.375,22 AWG	57668	JWW-0200E0
A1W556	131-0566-00		BUS CONDUCTOR:DUMMY RES,2.375,22 AWG	57668	JWW-0200E0
A1W558	131-0566-00		BUS CONDUCTOR:DUMMY RES,2.375,22 AWG	57668	JWW-0200E0
A1W560	131-0566-00		BUS CONDUCTOR:DUMMY RES,2.375,22 AWG	57668	JWW-0200E0
A1W570	131-0566-00		BUS CONDUCTOR:DUMMY RES,2.375,22 AWG	57668	JWW-0200E0
A1W582	131-0566-00		BUS CONDUCTOR:DUMMY RES,2.375,22 AWG	57668	JWW-0200E0
A1W590	131-0566-00		BUS CONDUCTOR:DUMMY RES,2.375,22 AWG	57668	JWW-0200E0
A1W591	131-0566-00		BUS CONDUCTOR:DUMMY RES,2.375,22 AWG	57668	JWW-0200E0
A1W592	131-0566-00		BUS CONDUCTOR:DUMMY RES,2.375,22 AWG	57668	JWW-0200E0
A1W602	131-0566-00		BUS CONDUCTOR:DUMMY RES,2.375,22 AWG	57668	JWW-0200E0
A1W603	131-0566-00		BUS CONDUCTOR:DUMMY RES,2.375,22 AWG	57668	JWW-0200E0
A1W635	131-0566-00		BUS CONDUCTOR:DUMMY RES,2.375,22 AWG	57668	JWW-0200E0
A1W649	131-0566-00		BUS CONDUCTOR:DUMMY RES,2.375,22 AWG	57668	JWW-0200E0
A1W732	131-0566-00		BUS CONDUCTOR:DUMMY RES,2.375,22 AWG	57668	JWW-0200E0
A1W770	131-0566-00		BUS CONDUCTOR:DUMMY RES,2.375,22 AWG	57668	JWW-0200E0
A1W780	131-0566-00		BUS CONDUCTOR:DUMMY RES,2.375,22 AWG	57668	JWW-0200E0
A1W885	131-0566-00		BUS CONDUCTOR:DUMMY RES,2.375,22 AWG	57668	JWW-0200E0
A1W954	131-0566-00		BUS CONDUCTOR:DUMMY RES,2.375,22 AWG	57668	JWW-0200E0
A1W955	131-0566-00		BUS CONDUCTOR:DUMMY RES,2.375,22 AWG	57668	JWW-0200E0
A1W956	131-0566-00		BUS CONDUCTOR:DUMMY RES,2.375,22 AWG	57668	JWW-0200E0
A1W959	131-0566-00		BUS CONDUCTOR:DUMMY RES,2.375,22 AWG	57668	JWW-0200E0
A1W960	131-0566-00		BUS CONDUCTOR:DUMMY RES,2.375,22 AWG	57668	JWW-0200E0
A1W961	131-0566-00		BUS CONDUCTOR:DUMMY RES,2.375,22 AWG	57668	JWW-0200E0
A1W964	131-0566-00		BUS CONDUCTOR:DUMMY RES,2.375,22 AWG	57668	JWW-0200E0
A1W965	131-0566-00		BUS CONDUCTOR:DUMMY RES,2.375,22 AWG	57668	JWW-0200E0
A1W968	131-0566-00		BUS CONDUCTOR:DUMMY RES,2.375,22 AWG	57668	JWW-0200E0
A1W971	131-0566-00		BUS CONDUCTOR:DUMMY RES,2.375,22 AWG	57668	JWW-0200E0
A1W972	131-0566-00		BUS CONDUCTOR:DUMMY RES,2.375,22 AWG	57668	JWW-0200E0
A1W974	131-0566-00		BUS CONDUCTOR:DUMMY RES,2.375,22 AWG	57668	JWW-0200E0
A1W975	131-0566-00		BUS CONDUCTOR:DUMMY RES,2.375,22 AWG	57668	JWW-0200E0

## Replaceable Electrical Parts—2235 Service

Component No.	Tektronix Part No.	Serial/Model No. Eff      Dscnt	Name & Description	Mfr Code	Mfr Part Number
A1W976	131-0566-00		BUS CONDUCTOR:DUMMY RES,2.375,22 AWG	57668	JWW-0200E0
A1W977	131-0566-00		BUS CONDUCTOR:DUMMY RES,2.375,22 AWG	57668	JWW-0200E0
A1W979	131-0566-00		BUS CONDUCTOR:DUMMY RES,2.375,22 AWG	57668	JWW-0200E0
A1W991	131-0566-00		BUS CONDUCTOR:DUMMY RES,2.375,22 AWG	57668	JWW-0200E0
A1W992	131-0566-00		BUS CONDUCTOR:DUMMY RES,2.375,22 AWG	57668	JWW-0200E0
A1W993	131-0566-00		BUS CONDUCTOR:DUMMY RES,2.375,22 AWG	57668	JWW-0200E0
A1W995	131-0566-00		BUS CONDUCTOR:DUMMY RES,2.375,22 AWG	57668	JWW-0200E0
A1W997	131-0566-00		BUS CONDUCTOR:DUMMY RES,2.375,22 AWG	57668	JWW-0200E0
A1W998	131-0566-00		BUS CONDUCTOR:DUMMY RES,2.375,22 AWG	57668	JWW-0200E0
A1W999	131-0566-00		BUS CONDUCTOR:DUMMY RES,2.375,22 AWG	57668	JWW-0200E0
A1W9000	131-1817-00		LINK,TERM CONNE:22 AWG,2.25" LONG	80009	131-1817-00
A1W9001	131-1817-00		LINK,TERM CONNE:22 AWG,2.25" LONG	80009	131-1817-00
A1W9041	195-7745-00		LEAD,ELECTRICAL:18 AWG,3.5 L,8-20	80009	195-7745-00
A1W9191	195-7747-00		LEAD,ELECTRICAL:18 AWG,3.5 L,8-19	80009	195-7747-00

# Replaceable Electrical Parts—2235 Service

Component No.	Tektronix Part No.	Serial/Model No. Eff Dscont	Name & Description	Mfr Code	Mfr Part Number
A2	670-7561-00		CKT BOARD ASSY:ATTENUATOR	80009	670-7561-00
A2AT1	307-1014-06		ATTENUATOR,FXD:100	80009	307-1014-06
A2AT2	307-1013-00		ATTENUATOR,FXD:10X	80009	307-1013-00
A2AT51	307-1014-06		ATTENUATOR,FXD:100	80009	307-1014-06
A2AT52	307-1013-00		ATTENUATOR,FXD:10X	80009	307-1013-00
A2C2	285-1132-02		CAP.,FXD,PLASTIC:0.019UF,10%,600V	80009	285-1132-02
A2C3	281-0182-00		CAP.,VAR,PLSTC:1.8-10PF,500V	80031	2805D1R810BH02F0
A2C6	283-0000-00		CAP.,FXD,CER DI:0.001UF,+100-0%,500V	59660	831610Y5U0102P
A2C9	281-0770-00		CAP.,FXD,CER DI:0.001UF,20%,100V	72982	8035D9AADX5R102M
A2C10	283-0028-00		CAP.,FXD,CER DI:0.0022UF,20%,50V	59660	0805585Y5SO222M
A2C13	281-0862-00		CAP.,FXD,CER DI:0.001UF,+80-20%,100V	20932	401-ES-100AD102Z
A2C17	281-0862-00		CAP.,FXD,CER DI:0.001UF,+80-20%,100V	20932	401-ES-100AD102Z
A2C21	281-0773-00		CAP.,FXD,CER DI:0.01UF,10%,100V	04222	SA201C103KAA
A2C26	281-0158-00		CAP.,VAR,CER D1:7.45PF,50V	73899	DVJ-5006
A2C27	281-0893-00		CAP.,FXD,CER DI:4.7PF,+/-0.5PF,100V	04222	MA101A4R7DAA
A2C30	281-0775-00		CAP.,FXD,CER DI:0.1UF,20%,50V	04222	MA205E104MAA
A2C35	281-0862-00		CAP.,FXD,CER DI:0.001UF,+80-20%,100V	20932	401-ES-100AD102Z
A2C38	281-0862-00		CAP.,FXD,CER DI:0.001UF,+80-20%,100V	20932	401-ES-100AD102Z
A2C52	285-1132-02		CAP.,FXD,PLASTIC:0.019UF,10%,600V	80009	285-1132-02
A2C53	281-0182-00		CAP.,VAR,PLSTC:1.8-10PF,500V	80031	2805D1R810BH02F0
A2C56	283-0000-00		CAP.,FXD,CER DI:0.001UF,+100-0%,500V	59660	831610Y5U0102P
A2C59	281-0770-00		CAP.,FXD,CER DI:0.001UF,20%,100V	72982	8035D9AADX5R102M
A2C60	283-0028-00		CAP.,FXD,CER DI:0.0022UF,20%,50V	59660	0805585Y5SO222M
A2C63	281-0862-00		CAP.,FXD,CER DI:0.001UF,+80-20%,100V	20932	401-ES-100AD102Z
A2C67	281-0862-00		CAP.,FXD,CER DI:0.001UF,+80-20%,100V	20932	401-ES-100AD102Z
A2C71	281-0773-00		CAP.,FXD,CER DI:0.01UF,10%,100V	04222	SA201C103KAA
A2C76	281-0158-00		CAP.,VAR,CER D1:7.45PF,50V	73899	DVJ-5006
A2C77	281-0893-00		CAP.,FXD,CER DI:4.7PF,+/-0.5PF,100V	04222	MA101A4R7DAA
A2C80	281-0775-00		CAP.,FXD,CER DI:0.1UF,20%,50V	04222	MA205E104MAA
A2C85	281-0862-00		CAP.,FXD,CER DI:0.001UF,+80-20%,100V	20932	401-ES-100AD102Z
A2C88	281-0862-00		CAP.,FXD,CER DI:0.001UF,+80-20%,100V	20932	401-ES-100AD102Z
A2C90	290-0523-00		CAP.,FXD,ELCTLT:2.2UF,20%,20V	56289	196D225X0020HA1
A2C91	290-0523-00		CAP.,FXD,ELCTLT:2.2UF,20%,20V	56289	196D225X0020HA1
A2C93	290-0776-00		CAP.,FXD,ELCTLT:22UF,+50-10%,10V	55680	ULA1A220TEA
A2C94	281-0862-00		CAP.,FXD,CER DI:0.001UF,+80-20%,100V	20932	401-ES-100AD102Z
A2C96	290-0776-00		CAP.,FXD,ELCTLT:22UF,+50-10%,10V	55680	ULA1A220TEA
A2C97	281-0862-00		CAP.,FXD,CER DI:0.001UF,+80-20%,100V	20932	401-ES-100AD102Z
A2CR7	152-0324-00		SEMICONV DEVICE:SILICON,35V,100MA	03508	DE103
A2CR18	152-0141-02		SEMICONV DEVICE:SILICON,30V,150MA	01295	1N4152R
A2CR57	152-0324-00		SEMICONV DEVICE:SILICON,35V,100MA	03508	DE103
A2CR68	152-0141-02		SEMICONV DEVICE:SILICON,30V,150MA	01295	1N4152R
A2E90	276-0532-00		SHIELDING BEAD,:	02114	56-590-65/4A6
A2E91	276-0532-00		SHIELDING BEAD,:	02114	56-590-65/4A6
A2L93	120-0382-00		XFMR,TOROID:14 TURNS,SINGLE	80009	120-0382-00
A2L96	120-0382-00		XFMR,TOROID:14 TURNS,SINGLE	80009	120-0382-00
A2Q13	151-1124-00		TRANSISTOR:JFE,N-CHAN,SI,SEL	22229	F2942
A2Q15	151-0711-00		TRANSISTOR:SILICON,NPN	04713	SPS8224
A2Q18	151-0711-00		TRANSISTOR:SILICON,NPN	04713	SPS8224
A2Q63	151-1124-00		TRANSISTOR:JFE,N-CHAN,SI,SEL	22229	F2942
A2Q65	151-0711-00		TRANSISTOR:SILICON,NPN	04713	SPS8224
A2Q68	151-0711-00		TRANSISTOR:SILICON,NPN	04713	SPS8224
A2R2	317-0105-00		RES.,FXD,CMPSN:1M OHM,5%,0.125W	01121	BB1055
A2R3	321-1731-00		RES.,FXD,FILM:500K OHM,1%,0.125W	24546	NA4D5003F

Replaceable Electrical Parts—2235 Service

Component No.	Tektronix Part No.	Serial/Model No. Eff Dscnt	Name & Description	Mfr Code	Mfr Part Number
A2R4	317-0056-00		RES.,FXD,CMPSN:5.6 OHM,5%,0.125W	01121	BB56G5
A2R5	321-1731-00		RES.,FXD,FILM:500K OHM,1%,0.125W	24546	NA4D5003F
A2R6	317-0474-00		RES.,FXD,CMPSN:470K OHM,5%,0.125W	01121	BB4745
A2R7	315-0160-00		RES.,FXD,CMPSN:16 OHM,5%,0.25W	01121	CB1605
A2R8	315-0220-01		RES.,FXD,CMPSN:22 OHM,5%,0.25W	01121	CB2205
A2R9	315-0112-00		RES.,FXD,CMPSN:1.1K OHM,5%,0.25W	01121	CB1125
A2R10	311-1559-00		RES.,VAR,NONWIR:10K OHM,20%,0.50W	73138	91-81-0
A2R11	315-0153-00		RES.,FXD,CMPSN:15K OHM,5%,0.25W	01121	CB1535
A2R13	315-0101-00		RES.,FXD,CMPSN:100 OHM,5%,0.25W	01121	CB1015
A2R14	317-0161-00		RES.,FXD,CMPSN:160 OHM,5%,0.125W	01121	BB1615
A2R15	315-0101-00		RES.,FXD,CMPSN:100 OHM,5%,0.25W	01121	CB1015
A2R17	315-0201-00		RES.,FXD,CMPSN:200 OHM,5%,0.25W	01121	CB2015
A2R18	315-0911-00		RES.,FXD,CMPSN:910 OHM,5%,0.25W	01121	CB9115
A2R19	307-0843-00		RES.,NTWK,FXD,FI:INPUT ATTENUATOR	80009	307-0843-00
A2R21	315-0160-00		RES.,FXD,CMPSN:16 OHM,5%,0.25W	01121	CB1605
A2R22	321-0210-00		RES.,FXD,FILM:1.5K OHM,1%,0.125W	91637	MFF1816G15000F
A2R23	321-0210-00		RES.,FXD,FILM:1.5K OHM,1%,0.125W	91637	MFF1816G15000F
A2R25	311-1568-00		RES.,VAR,NONWIR:50 OHM,20%,0.50W	73138	91-90-0
A2R26	311-0643-00		RES.,VAR,NONWIR:50 OHM,10%,0.50W	73138	82-33-2
A2R27	315-0160-00		RES.,FXD,CMPSN:16 OHM,5%,0.25W	01121	CB1605
A2R29	321-0090-00		RES.,FXD,FILM:84.5 OHM,1%,0.125W	91637	MFF1816G84R50F
A2R30	315-0124-00		RES.,FXD,CMPSN:120K OHM,5%,0.25W	01121	CB1245
A2R31	315-0750-00		RES.,FXD,CMPSN:75 OHM,5%,0.25W	01121	CB7505
A2R33	311-1556-00		RES.,VAR,NONWIR:50K OHM,20%,0.50W	73138	91-78-0
A2R34	315-0101-00		RES.,FXD,CMPSN:100 OHM,5%,0.25W	01121	CB1015
A2R35	321-0144-00		RES.,FXD,FILM:309 OHM,1%,0.125W	91637	MFF1816G309R0F
A2R37	315-0102-00		RES.,FXD,CMPSN:1K OHM,5%,0.25W	01121	CB1025
A2R38	321-0144-00		RES.,FXD,FILM:309 OHM,1%,0.125W	91637	MFF1816G309R0F
A2R39	315-0242-00		RES.,FXD,CMPSN:2.4K OHM,5%,0.25W	01121	CB2425
A2R41	321-0154-00		RES.,FXD,FILM:392 OHM,1%,0.125W	91637	MFF1816G392R0F
A2R42	315-0333-00		RES.,FXD,CMPSN:33K OHM,5%,0.25W	01121	CB3335
A2R43	311-2179-00		RES.,VAR,NONWIR:PNL,10 OHM,10%,0.5W	32997	91Z1D-Z07-EA0037
A2R46	315-0472-00		RES.,FXD,CMPSN:4.7K OHM,5%,0.25W	01121	CB4725
A2R47	311-1224-00		RES.,VAR,NONWIR:500 OHM,20%,0.50W	32997	3386F-T04-501
A2R48	315-0512-00		RES.,FXD,CMPSN:5.1K OHM,5%,0.25W	01121	CB5125
A2R52	317-0105-00		RES.,FXD,CMPSN:1M OHM,5%,0.125W	01121	BB1055
A2R53	321-1731-00		RES.,FXD,FILM:500K OHM,1%,0.125W	24546	NA4D5003F
A2R54	317-0056-00		RES.,FXD,CMPSN:5.6 OHM,5%,0.125W	01121	BB56G5
A2R55	321-1731-00		RES.,FXD,FILM:500K OHM,1%,0.125W	24546	NA4D5003F
A2R56	317-0474-00		RES.,FXD,CMPSN:470K OHM,5%,0.125W	01121	BB4745
A2R57	315-0160-00		RES.,FXD,CMPSN:16 OHM,5%,0.25W	01121	CB1605
A2R58	315-0220-01		RES.,FXD,CMPSN:22 OHM,5%,0.25W	01121	CB2205
A2R59	315-0112-00		RES.,FXD,CMPSN:1.1K OHM,5%,0.25W	01121	CB1125
A2R60	311-1559-00		RES.,VAR,NONWIR:10K OHM,20%,0.50W	73138	91-81-0
A2R61	315-0153-00		RES.,FXD,CMPSN:15K OHM,5%,0.25W	01121	CB1535
A2R63	315-0101-00		RES.,FXD,CMPSN:100 OHM,5%,0.25W	01121	CB1015
A2R64	317-0161-00		RES.,FXD,CMPSN:160 OHM,5%,0.125W	01121	BB1615
A2R65	315-0101-00		RES.,FXD,CMPSN:100 OHM,5%,0.25W	01121	CB1015
A2R67	315-0201-00		RES.,FXD,CMPSN:200 OHM,5%,0.25W	01121	CB2015
A2R68	315-0911-00		RES.,FXD,CMPSN:910 OHM,5%,0.25W	01121	CB9115
A2R69	307-0843-00		RES.,NTWK,FXD,FI:INPUT ATTENUATOR	80009	307-0843-00
A2R71	315-0160-00		RES.,FXD,CMPSN:16 OHM,5%,0.25W	01121	CB1605
A2R72	321-0210-00		RES.,FXD,FILM:1.5K OHM,1%,0.125W	91637	MFF1816G15000F
A2R73	321-0210-00		RES.,FXD,FILM:1.5K OHM,1%,0.125W	91637	MFF1816G15000F

## Replaceable Electrical Parts—2235 Service

Component No.	Tektronix Part No.	Serial/Model No. Eff Dscont	Name & Description	Mfr Code	Mfr Part Number
A2R75	311-1568-00		RES.,VAR,NONWIR:50 OHM,20%,0.50W	73138	91-90-0
A2R76	311-0643-00		RES.,VAR,NONWIR:50 OHM,10%,0.50W	73138	82-33-2
A2R77	315-0160-00		RES.,FXD,CMPSN:16 OHM,5%,0.25W	01121	CB1605
A2R79	321-0090-00		RES.,FXD,FILM:84.5 OHM,1%,0.125W	91637	MFF1816G84R50F
A2R80	315-0124-00		RES.,FXD,CMPSN:120K OHM,5%,0.25W	01121	CB1245
A2R81	315-0750-00		RES.,FXD,CMPSN:75 OHM,5%,0.25W	01121	CB7505
A2R83	311-1556-00		RES.,VAR,NONWIR:50K OHM,20%,0.50W	73138	91-78-0
A2R84	315-0101-00		RES.,FXD,CMPSN:100 OHM,5%,0.25W	01121	CB1015
A2R85	321-0144-00		RES.,FXD,FILM:309 OHM,1%,0.125W	91637	MFF1816G309R0F
A2R87	315-0102-00		RES.,FXD,CMPSN:1K OHM,5%,0.25W	01121	CB1025
A2R88	321-0144-00		RES.,FXD,FILM:309 OHM,1%,0.125W	91637	MFF1816G309R0F
A2R91	321-0154-00		RES.,FXD,FILM:392 OHM,1%,0.125W	91637	MFF1816G392R0F
A2R93	311-2179-00		RES.,VAR,NONWW:PNL,10 OHM,10%,0.5W	32997	91Z1D-Z07-EA0037
A2R96	315-0472-00		RES.,FXD,CMPSN:4.7K OHM,5%,0.25W	01121	CB4725
A2R97	311-1224-00		RES.,VAR,NONWIR:500 OHM,20%,0.50W	32997	3386F-T04-501
A2R98	315-0512-00		RES.,FXD,CMPSN:5.1K OHM,5%,0.25W	01121	CB5125
A2R9100	315-0620-00		RES.,FXD,CMPSN:62 OHM,5%,0.25W	01121	CB6205
A2R9510	315-0620-00		RES.,FXD,CMPSN:62 OHM,5%,0.25W	01121	CB6205
A2S1	105-0934-00		ACTUATOR,CAM SW:AC-GND-DC	80009	105-0934-00
A2S10	105-0935-00		ACTUATOR,CAM SW:ATTENUATOR	80009	105-0935-00
A2S51	105-0934-00		ACTUATOR,CAM SW:AC-GND-DC	80009	105-0934-00
A2S60	105-0935-00		ACTUATOR,CAM SW:ATTENUATOR	80009	105-0935-00
A2U10	156-1134-01		MICROCIRCUIT,LI:OPNL AMP,MOS/FET INPUT	02735	CA3140AE
A2U30	155-0273-00		MICROCIRCUIT,LI:ATTEN AMPLIFIER	80009	155-0273-00
A2U60	156-1134-01		MICROCIRCUIT,LI:OPNL AMP,MOS/FET INPUT	02735	CA3140AE
A2U80	155-0273-00		MICROCIRCUIT,LI:ATTEN AMPLIFIER	80009	155-0273-00
A2W43	131-0566-00		BUS CONDUCTOR:DUMMY RES,2.375,22 AWG	57668	JWW-0200E0
A2W93	131-0566-00		BUS CONDUCTOR:DUMMY RES,2.375,22 AWG	57668	JWW-0200E0
A2W94	131-0566-00		BUS CONDUCTOR:DUMMY RES,2.375,22 AWG	57668	JWW-0200E0
A2W96	131-0566-00		BUS CONDUCTOR:DUMMY RES,2.375,22 AWG	57668	JWW-0200E0

Replaceable Electrical Parts—2235 Service

Component No.	Tektronix Part No.	Serial/Model No. Eff Dscnt	Name & Description	Mfr Code	Mfr Part Number
A3	670-7611-00		CKT BOARD ASSY:FRONT PANEL	80009	670-7611-00
A3C376	283-0006-00		CAP.,FXD,CER DI:0.02UF,+80-20%,500V	59660	0841545Z5V00203Z
A3C377	281-0576-00		CAP.,FXD,CER DI:11PF,5%,500V	59660	301-000C0G0110J
A3C379	283-0780-00		CAP.,FXD,MICA D:125PF,1%,500V	00853	D155F1250F0
A3C380	281-0578-00		CAP.,FXD,CER DI:18PF,5%,500V	59660	301-050C0G0180J
A3C987	281-0773-00		CAP.,FXD,CER DI:0.01UF,10%,100V	04222	SA201C103KAA
A3CR534	152-0141-02		SEMICONV DEVICE:SILICON,30V,150MA	01295	1N4152R
A3CR537	152-0141-02		SEMICONV DEVICE:SILICON,30V,150MA	01295	1N4152R
A3CR538	152-0141-02		SEMICONV DEVICE:SILICON,30V,150MA	01295	1N4152R
A3CR539	152-0141-02		SEMICONV DEVICE:SILICON,30V,150MA	01295	1N4152R
A3CR648	152-0141-02		SEMICONV DEVICE:SILICON,30V,150MA	01295	1N4152R
A3CR988	152-0141-02		SEMICONV DEVICE:SILICON,30V,150MA	01295	1N4152R
A3CR989	152-0141-02		SEMICONV DEVICE:SILICON,30V,150MA	01295	1N4152R
A3DS518	150-1029-00		LT EMITTING DIO:GREEN,565NM,35MA	53184	XC209G
A3R89	315-0242-00		RES.,FXD,CMPSN:2.4K OHM,5%,0.25W	01121	CB2425
A3R92	315-0333-00		RES.,FXD,CMPSN:33K OHM,5%,0.25W	01121	CB3335
A3R111	321-0251-00		RES.,FXD,FILM:4.02K OHM,1%,0.125W	91637	MFF1816G40200F
A3R112	311-2178-00		RES.,VAR,NONWW:PNL,500 OHM,10%,0.5W	01121	W8650A
A3R161	321-0251-00		RES.,FXD,FILM:4.02K OHM,1%,0.125W	91637	MFF1816G40200F
A3R162	311-2178-00		RES.,VAR,NONWW:PNL,500 OHM,10%,0.5W	01121	W8650A
A3R280	311-2147-00		RES.,VAR,NONWIR:PNL,5K OHM,20%,0.50W	01121	W8615B
A3R377	321-0807-00		RES.,FXD,FILM:900K OHM,1%,0.125W	91637	HFF1104F90002F
A3R378	321-0617-00		RES.,FXD,FILM:111K OHM,1%,0.125W	91637	MFF1816G11102F
A3R379	315-0220-00		RES.,FXD,CMPSN:22 OHM,5%,0.25W	01121	CB2205
A3R380	321-0459-00		RES.,FXD,FILM:590K OHM,1%,0.125W	91637	MFF1816G59002F
A3R438	311-2178-00		RES.,VAR,NONWW:PNL,500 OHM,10%,0.5W	01121	W8650A
A3R519	315-0682-00		RES.,FXD,CMPSN:6.8K OHM,5%,0.25W	01121	CB6825
A3R520	315-0912-00		RES.,FXD,CMPSN:9.1K OHM,5%,0.25W	01121	CB9125
A3R602	311-2147-00		RES.,VAR,NONWIR:PNL,5K OHM,20%,0.50W	01121	W8615B
A3R726	311-2147-00		RES.,VAR,NONWIR:PNL,5K OHM,20%,0.50W	01121	W8615B
A3R982	311-1560-00		RES.,VAR,NONWIR:5K OHM,20%,0.50W	73138	91-82-0
A3R983	315-0241-00		RES.,FXD,CMPSN:240 OHM,5%,0.25W	01121	CB2415
A3R985	315-0124-00		RES.,FXD,CMPSN:120K OHM,5%,0.25W	01121	CB1245
A3R986	315-0434-00		RES.,FXD,CMPSN:430K OHM,5%,0.25W	01121	CB4345
A3R987	315-0124-00		RES.,FXD,CMPSN:120K OHM,5%,0.25W	01121	CB1245
A3R988	315-0182-00		RES.,FXD,CMPSN:1.8K OHM,5%,0.25W	01121	CB1825
A3R989	321-0239-00		RES.,FXD,FILM:3.01K OHM,1%,0.125W	91637	MFF1816G30100F
A3R990	321-0126-00		RES.,FXD,FILM:200 OHM,1%,0.125W	91637	MFF1816G200R0F
A3R9376	315-0510-00		RES.,FXD,CMPSN:51 OHM,5%,0.25W	01121	CB5105
A3S90	260-1995-00		SWITCH,PUSH:DPDT,SLOPE	71590	K40352AB
A3S200	260-2111-00		SWITCH,PUSH:1 BUTTON,1 POLE,BEAM FIND	80009	260-2111-00
A3S226	260-2075-00		SWITCH,PUSH:SPDT,50VDC,500M AMP	80009	260-2075-00
A3S380	260-2033-00		SWITCH,SLIDE:DPPT,125V,0.5A	82389	OBD
A3S390	260-2111-00		SWITCH,PUSH:1 BUTTON,1 POLE,BEAM FIND	80009	260-2111-00
A3S392	260-2033-00		SWITCH,SLIDE:DPPT,125V,0.5A	82389	OBD
A3S401	260-2110-00		SWITCH,PUSH:3 BUTTON,2 POLE,TRIG MODE	80009	260-2110-00
A3S460	260-2075-00		SWITCH,PUSH:SPDT,50VDC,500M AMP	80009	260-2075-00
A3S532	260-2110-00		SWITCH,PUSH:3 BUTTON,2 POLE,TRIG MODE	80009	260-2110-00
A3S545	260-2033-00		SWITCH,SLIDE:DPPT,125V,0.5A	82389	OBD
A3S550	260-2033-00		SWITCH,SLIDE:DPPT,125V,0.5A	82389	OBD
A3S555	260-2033-00		SWITCH,SLIDE:DPPT,125V,0.5A	82389	OBD
A3S602	260-2075-00		SWITCH,PUSH:SPDT,50VDC,500M AMP	80009	260-2075-00
A3S648	260-2033-00		SWITCH,SLIDE:DPPT,125V,0.5A	82389	OBD

## Replaceable Electrical Parts—2235 Service

Component No.	Tektronix	Serial/Model No.		Name & Description	Mfr	Mfr Part Number
	Part No.	Eff	Dscont		Code	
A3U985	156-0067-00			MICROCIRCUIT,LI:OPERATIONAL AMPLIFIER	01295	MICROA741CP
A3W89	131-0566-00			BUS CONDUCTOR:DUMMY RES,2.375,22 AWG	57668	JWW-0200E0
A3W515	131-0566-00			BUS CONDUCTOR:DUMMY RES,2.375,22 AWG	57668	JWW-0200E0
A3W534	131-0566-00			BUS CONDUCTOR:DUMMY RES,2.375,22 AWG	57668	JWW-0200E0
A3W539	131-0566-00			BUS CONDUCTOR:DUMMY RES,2.375,22 AWG	57668	JWW-0200E0
A3W630	131-0566-00			BUS CONDUCTOR:DUMMY RES,2.375,22 AWG	57668	JWW-0200E0

Replaceable Electrical Parts—2235 Service

Component No.	Tektronix Part No.	Serial/Model No. Eff Dscnt	Name & Description	Mfr Code	Mfr Part Number
A4	670-7613-00		CKT BOARD ASSY:TIMING	80009	670-7613-00
A4C701	295-0194-00		CAP SET,MATCHED:2 EA 1.0UF,1.5%,50V	90201	TTX 100 + 100
A4C702	283-0674-00		CAP.,FXD,MICA D:85PF,1%,500V	00853	D155F850F0
A4C703	281-0207-00		CAP.,VAR,PLSTC:2-18PF,100V	80031	2807C00218MH02F0
A4C705	281-0813-00		CAP.,FXD CER DI:0.047UF,20%,50V	04222	GC705-E-473M
A4C706	281-0773-00		CAP.,FXD,CER DI:0.01UF,10%,100V	04222	SA201C103KAA
A4C707	281-0773-00		CAP.,FXD,CER DI:0.01UF,10%,100V	04222	SA201C103KAA
A4C708	281-0756-00		CAP.,FXD,CER DI:2.2PF,0.5%,200V	12969	CGB2R2DFN
A4C710	281-0813-00		CAP.,FXD CER DI:0.047UF,20%,50V	04222	GC705-E-473M
A4C712	283-0674-00		CAP.,FXD,MICA D:85PF,1%,500V	00853	D155F850F0
A4C713	281-0207-00		CAP.,VAR,PLSTC:2-18PF,100V	80031	2807C00218MH02F0
A4C714	281-0756-00		CAP.,FXD,CER DI:2.2PF,0.5%,200V	12969	CGB2R2DFN
A4C715	290-0776-00		CAP.,FXD,ELCTL:22UF,+50-10%,10V	55680	ULA1A220TEA
A4C720	281-0773-00		CAP.,FXD,CER DI:0.1UF,20%,50V	04222	MA205E104MAA
A4C724	281-0773-00		CAP.,FXD,CER DI:0.01UF,10%,100V	04222	SA201C103KAA
A4C728	283-0203-00		CAP.,FXD,CER DI:0.47UF,20%,50V	72982	8131M058Z5U0474M
A4C749	281-0775-00		CAP.,FXD,CER DI:0.1UF,20%,50V	04222	MA205E104MAA
A4C750	290-0246-00		CAP.,FXD,ELCTL:3.3UF,10%,15V	56289	162D335X9015CD2
A4C751	281-0809-00		CAP.,FXD,CER DI:200PF,5%,100V	72982	8013T2ADDC1G201J
A4C752	281-0775-00		CAP.,FXD,CER DI:0.1UF,20%,50V	04222	MA205E104MAA
A4C755	283-0107-00		CAP.,FXD,CER DI:51PF,5%,200V	96733	R3017
A4CR732	152-0141-02		SEMICONV DEVICE:SILICON,30V,150MA	01295	1N4152R
A4CR742	152-0141-02		SEMICONV DEVICE:SILICON,30V,150MA	01295	1N4152R
A4Q701	151-0424-00		TRANSISTOR:SILICON,NPN	04713	SPS8246
A4Q704	151-1042-00		SEMICONV DVC SE:MATCHED PAIR FET	01295	SKA5390
A4Q706	151-0736-00		TRANSISTOR:SILICON,NPN	04713	SPS8317
A4Q709	151-0424-00		TRANSISTOR:SILICON,NPN	04713	SPS8246
A4Q710	151-1042-00		SEMICONV DVC SE:MATCHED PAIR FET	01295	SKA5390
A4Q712	151-0736-00		TRANSISTOR:SILICON,NPN	04713	SPS8317
A4Q732	151-0712-00		TRANSISTOR:SILICON,NPN	04713	SPS8223
A4Q737	151-0188-00		TRANSISTOR:SILICON,PNP	04713	SPS6868K
A4Q742	151-0712-00		TRANSISTOR:SILICON,NPN	04713	SPS8223
A4R701	307-0780-01		RES,NTWK,FXD,FI:TIMING	80009	307-0780-01
A4R702	322-0519-01		RES.,FXD,FILM:2.49M OHM,0.5%,0.25W	91637	HFF143G24903D
A4R703	315-0100-00		RES.,FXD,CMPSN:10 OHM,5%,0.25W	01121	CB1005
A4R705	315-0151-00		RES.,FXD,CMPSN:150 OHM,5%,0.25W	01121	CB1515
A4R707	301-0202-00		RES.,FXD,CMPSN:2K OHM,5%,0.50W	01121	EB2025
A4R709	315-0100-00		RES.,FXD,CMPSN:10 OHM,5%,0.25W	01121	CB1005
A4R710	315-0151-00		RES.,FXD,CMPSN:150 OHM,5%,0.25W	01121	CB1515
A4R711	307-0780-01		RES,NTWK,FXD,FI:TIMING	80009	307-0780-01
A4R713	301-0202-00		RES.,FXD,CMPSN:2K OHM,5%,0.50W	01121	EB2025
A4R715	321-0308-00		RES.,FXD,FILM:15.8K OHM,1%,0.125W	91637	MFF1816G15801F
A4R716	321-0303-00		RES.,FXD,FILM:14K OHM,1%,0.125W	91637	MFF1816G14001F
A4R717	321-0306-00		RES.,FXD,FILM:15K OHM,1%,0.125W	91637	MFF1816G15001F
A4R718	321-0306-00		RES.,FXD,FILM:15K OHM,1%,0.125W	91637	MFF1816G15001F
A4R719	315-0330-00		RES.,FXD,CMPSN:33 OHM,5%,0.25W	01121	CB3305
A4R721	311-2151-00		RES.,VAR,NONWIR:PNL,500 OHM,20%,0.5W,DPST	12697	0BD
A4R722	315-0201-00		RES.,FXD,CMPSN:200 OHM,5%,0.25W	01121	CB2015
A4R724	315-0200-00		RES.,FXD,CMPSN:20 OHM,5%,0.25W	01121	CB2005
A4R727	321-0246-00		RES.,FXD,FILM:3.57K OHM,1%,0.125W	91637	MFF1816G35700F
A4R728	321-0211-00		RES.,FXD,FILM:1.54K OHM,1%,0.125W	91637	MFF1816G15400F
A4R730	311-0635-00		RES.,VAR,NONWIR:1K OHM,10%,0.5%,0.5W	73138	82P-6-2-102K
A4R731	321-0244-00		RES.,FXD,FILM:3.4K OHM,1%,0.125W	91637	MFF1816G34000F

## Replaceable Electrical Parts—2235 Service

Component No.	Tektronix Part No.	Serial/Model No. Eff Dscont	Name & Description	Mfr Code	Mfr Part Number
A4R732	321-0198-00		RES.,FXD,FILM:1.13K OHM,1%,0.125W	91637	MFF1816G11300F
A4R733	321-0203-00		RES.,FXD,FILM:1.27K OHM,1%,0.125W	91637	MFF1816G12700F
A4R737	315-0392-00		RES.,FXD,CMPSN:3.9K OHM,5%,0.25W	01121	CB3925
A4R738	315-0512-00		RES.,FXD,CMPSN:5.1K OHM,5%,0.25W	01121	CB5125
A4R740	311-0635-00		RES.,VAR,NONWIR:1K OHM,10%,0.5%,0.5W	73138	82P-6-2-102K
A4R741	321-0244-00		RES.,FXD,FILM:3.4K OHM,1%,0.125W	91637	MFF1816G34000F
A4R742	321-0198-00		RES.,FXD,FILM:1.13K OHM,1%,0.125W	91637	MFF1816G11300F
A4R743	321-0203-00		RES.,FXD,FILM:1.27K OHM,1%,0.125W	91637	MFF1816G12700F
A4R745	321-0177-00		RES.,FXD,FILM:681 OHM,1%,0.125W	91637	MFF1816G681R0F
A4R746	321-0184-00		RES.,FXD,FILM:806 OHM,1%,0.125W	91637	MFF1816G806R0F
A4R748	315-0113-00		RES.,FXD,CMPSN:11K OHM,5%,0.25W	01121	CB1135
A4R749	311-1560-00		RES.,VAR,NONWIR:5K OHM,20%,0.50W	73138	91-82-0
A4R750	315-0113-00		RES.,FXD,CMPSN:11K OHM,5%,0.25W	01121	CB1135
A4R751	321-0326-00		RES.,FXD,FILM:24.3K OHM,1%,0.125W	91637	MFF1816G24301F
A4R752	315-0100-00		RES.,FXD,CMPSN:10 OHM,5%,0.25W	01121	CB1005
A4R753	321-0216-00		RES.,FXD,FILM:1.74K OHM,1%,0.125W	91637	MFF1816G17400F
A4R754	311-0622-00		RES.,VAR,NONWIR:100 OHM,10%,0.50W	32997	3329H-G48-101
A4R755	315-0121-00		RES.,FXD,CMPSN:120 OHM,5%,0.25W	01121	CB1215
A4RT715	307-0125-00		RES.,THERMAL:500 OHM,10%,25 DEG C	50157	2D1595
A4S701	260-2023-01		SWITCH,ROTARY:A/B SWEEP	80009	260-2023-01
A4U715	156-0067-00		MICROCIRCUIT,LI:OPERATIONAL AMPLIFIER	01295	MICROA741CP
A4U750	156-1150-00		MICROCIRCUIT,LI:VOLTAGE REGULATOR,NEGATIVE	04713	MC79L05ACP
A4U760	155-0124-00		MICROCIRCUIT,LI:HORIZONTAL PREAMPL	80009	155-0124-00
A4VR720	152-0744-00		SEMICONV DEVICE:ZEN,SI,3.6V,5%,0.4W	04713	1N747A
A4VR749	152-0744-00		SEMICONV DEVICE:ZEN,SI,3.6V,5%,0.4W	04713	1N747A
A4W709	131-0566-00		BUS CONDUCTOR:DUMMY RES.2.375,22 AWG	57668	JWW-0200E0

Replaceable Electrical Parts—2235 Service

Component No.	Tektronix Part No.	Serial/Model No. Eff Dscont	Name & Description	Mfr Code	Mfr Part Number
A5	670-7612-00		CKT BOARD ASSY:ALTERNATE SWEEP	80009	670-7612-00
A5C610	281-0862-00		CAP.,FXD,CER DI:0.001UF,+80-20%,100V	20932	401-ES-100AD102Z
A5C624	281-0826-00		CAP.,FXD,CER DI:2200PF,5%,100V	12969	CGC222KEX
A5C627	281-0893-00		CAP.,FXD,CER DI:4.7PF,+/-0.5PF,100V	04222	MA101A4R7DAA
A5C643	281-0811-00		CAP.,FXD,CER DI:10PF,10%,100V	72982	8035D2AADC1G100K
A5C655	281-0773-00		CAP.,FXD,CER DI:0.01UF,10%,100V	04222	SA201C103KAA
A5C659	281-0773-00		CAP.,FXD,CER DI:0.01UF,10%,100V	04222	SA201C103KAA
A5C665	281-0810-00		CAP.,FXD,CER DI:5.6PF,0.5%,100V	04222	GC10-1A5R6D
A5C671	281-0851-00		CAP.,FXD,CER DI:180PF,5%,100VDC	20932	401E0100AD181J
A5C672	281-0759-00		CAP.,FXD,CER DI:22PF,10%,100V	72982	8035D9AADC1G220K
A5C690	281-0772-00		CAP.,FXD,CER DI:0.0047UF,10%,100V	04222	GC701C472K
A5C693	290-0776-00		CAP.,FXD,ELCTLT:22UF,+50-10%,10V	55680	ULA1A220TEA
A5C694	281-0775-00		CAP.,FXD,CER DI:0.1UF,20%,50V	04222	MA205E104MAA
A5CR680	152-0141-02		SEMICONV DEVICE:SILICON,30V,150MA	01295	1N4152R
A5CR685	152-0141-02		SEMICONV DEVICE:SILICON,30V,150MA	01295	1N4152R
A5CR816	152-0153-00		SEMICONV DEVICE:SILICON,15V,50MA	07263	FD7003
A5CR817	152-0141-02		SEMICONV DEVICE:SILICON,30V,150MA	01295	1N4152R
A5Q619	151-0712-00		TRANSISTOR:SILICON,NPN	04713	SPS8223
A5Q620	151-0712-00		TRANSISTOR:SILICON,NPN	04713	SPS8223
A5Q630	151-0369-00		TRANSISTOR:SILICON,PNP	01295	SKA6664
A5Q631	151-0369-00		TRANSISTOR:SILICON,PNP	01295	SKA6664
A5Q637	151-0276-00		TRANSISTOR:SILICON,PNP	80009	151-0276-00
A5Q643	151-0190-00		TRANSISTOR:SILICON,NPN	07263	S032677
A5Q680	151-0198-00		TRANSISTOR:SILICON,NPN,SEL FROM MPS918	04713	SPS8802-1
A5Q685	151-0198-00		TRANSISTOR:SILICON,NPN,SEL FROM MPS918	04713	SPS8802-1
A5R604	315-0242-00		RES.,FXD,CMPSN:2.4K OHM,5%,0.25W	01121	CB2425
A5R605	321-0203-00		RES.,FXD,FILM:1.27K OHM,1%,0.125W	91637	MFF1816G12700F
A5R606	321-0201-00		RES.,FXD,FILM:1.21K OHM,1%,0.125W	91637	MFF1816G12100F
A5R609	315-0222-00		RES.,FXD,CMPSN:2.2K OHM,5%,0.25W	01121	CB2225
A5R610	315-0241-00		RES.,FXD,CMPSN:240 OHM,5%,0.25W	01121	CB2415
A5R611	315-0470-00		RES.,FXD,CMPSN:47 OHM,5%,0.25W	01121	CB4705
A5R614	315-0302-00		RES.,FXD,CMPSN:3K OHM,5%,0.25W	01121	CB3025
A5R616	321-0207-00		RES.,FXD,FILM:1.4K OHM,1%,0.125W	91637	MFF1816G14000F
A5R617	321-0197-00		RES.,FXD,FILM:1.1K OHM,1%,0.125W	91637	MFF1816G11000F
A5R619	321-0092-00		RES.,FXD,FILM:88.7 OHM,1%,0.125W	91637	MFF1816G88R70F
A5R620	321-0090-00		RES.,FXD,FILM:84.5 OHM,1%,0.125W	91637	MFF1816G84R50F
A5R621	315-0271-00		RES.,FXD,CMPSN:270 OHM,5%,0.25W	01121	CB2715
A5R623	315-0910-00		RES.,FXD,CMPSN:91 OHM,5%,0.25W	01121	CB9105
A5R624	301-0430-00		RES.,FXD,CMPSN:43 OHM,5%,0.50W	01121	EB4305
A5R625	315-0431-00		RES.,FXD,CMPSN:430 OHM,5%,0.25W	01121	CB4315
A5R626	315-0431-00		RES.,FXD,CMPSN:430 OHM,5%,0.25W	01121	CB4315
A5R627	315-0201-00		RES.,FXD,CMPSN:200 OHM,5%,0.25W	01121	CB2015
A5R629	315-0471-00		RES.,FXD,CMPSN:470 OHM,5%,0.25W	01121	CB4715
A5R630	315-0471-00		RES.,FXD,CMPSN:470 OHM,5%,0.25W	01121	CB4715
A5R631	315-0471-00		RES.,FXD,CMPSN:470 OHM,5%,0.25W	01121	CB4715
A5R632	315-0181-00		RES.,FXD,CMPSN:180 OHM,5%,0.25W	01121	CB1815
A5R633	315-0302-00		RES.,FXD,CMPSN:3K OHM,5%,0.25W	01121	CB3025
A5R634	315-0201-00		RES.,FXD,CMPSN:200 OHM,5%,0.25W	01121	CB2015
A5R637	315-0104-00		RES.,FXD,CMPSN:100K OHM,5%,0.25W	01121	CB1045
A5R638	315-0102-00		RES.,FXD,CMPSN:1K OHM,5%,0.25W	01121	CB1025
A5R640	315-0114-00		RES.,FXD,CMPSN:110K OHM,5%,0.25W	01121	CB1145
A5R642	321-0314-00		RES.,FXD,FILM:18.2K OHM,1%,0.125W	91637	MFF1816G18201F
A5R643	321-0322-00		RES.,FXD,FILM:22.1K OHM,1%,0.125W	91637	MFF1816G22101F

## Replaceable Electrical Parts—2235 Service

Component No.	Tektronix Part No.	Serial/Model No. Eff Dscont	Name & Description	Mfr Code	Mfr Part Number
A5R644	315-0512-00		RES.,FXD,CMPSN:5.1K OHM,5%,0.25W	01121	CB5125
A5R651	321-0277-00		RES.,FXD,FILM:7.5K OHM,1%,0.125W	91637	MFF1816G75000F
A5R652	311-1238-00		RES.,VAR,NONWIR:5K OHM,10%,0.50W	73138	72-27-0
A5R653	321-0289-00		RES.,FXD,FILM:10K OHM,1%,0.125W	91637	MFF1816G10001F
A5R657	315-0102-00		RES.,FXD,CMPSN:1K OHM,5%,0.25W	01121	CB1025
A5R660	315-0471-00		RES.,FXD,CMPSN:470 OHM,5%,0.25W	01121	CB4715
A5R662	315-0392-00		RES.,FXD,CMPSN:3.9K OHM,5%,0.25W	01121	CB3925
A5R663	315-0102-00		RES.,FXD,CMPSN:1K OHM,5%,0.25W	01121	CB1025
A5R664	315-0392-00		RES.,FXD,CMPSN:3.9K OHM,5%,0.25W	01121	CB3925
A5R665	315-0204-00		RES.,FXD,CMPSN:200K OHM,5%,0.25W	01121	CB2045
A5R666	315-0221-00		RES.,FXD,CMPSN:220 OHM,5%,0.25W	01121	CB2215
A5R670	315-0512-00		RES.,FXD,CMPSN:5.1K OHM,5%,0.25W	01121	CB5125
A5R671	315-0681-00		RES.,FXD,CMPSN:680 OHM,5%,0.25W	01121	CB6815
A5R672	315-0331-00		RES.,FXD,CMPSN:330 OHM,5%,0.25W	01121	CB3315
A5R674	315-0512-00		RES.,FXD,CMPSN:5.1K OHM,5%,0.25W	01121	CB5125
A5R677	315-0471-00		RES.,FXD,CMPSN:470 OHM,5%,0.25W	01121	CB4715
A5R690	315-0100-00		RES.,FXD,CMPSN:10 OHM,5%,0.25W	01121	CB1005
A5R693	307-0106-00		RES.,FXD,CMPSN:4.7 OHM,5%,0.25W	01121	CB47G5
A5R816	315-0562-00		RES.,FXD,CMPSN:5.6K OHM,5%,0.25W	01121	CB5625
A5R817	315-0302-00		RES.,FXD,CMPSN:3K OHM,5%,0.25W	01121	CB3025
A5U605	156-0534-00		MICROCIRCUIT,LI:DUAL DIFF AMPL,14 LD DIP	80009	156-0534-00
A5U625	156-1641-00		MICROCIRCUIT,DI:ECL,QUAD 2-INPUT NOR GATE	80009	156-1641-00
A5U655	156-1126-00		MICROCIRCUIT,LI:VOLTAGE COMPARATOR	51984	UPC311C
A5U660	156-0385-02		MICROCIRCUIT,DI:HEX INVERTER	01295	SN74LS04
A5U665	156-0382-02		MICROCIRCUIT,DI:QUAD 2-INP NAND GATE	01295	SN74LS00
A5U670	156-1611-00		MICROCIRCUIT,DI:DUAL D TYPE EDGE-TRIGGERED	07263	74F74
A5U680	156-0382-02		MICROCIRCUIT,DI:QUAD 2-INP NAND GATE	01295	SN74LS00
A5VR624	152-0195-00		SEMICONV DEVICE:ZENER,0.4W,5.1V,5%	04713	SZ11755
A5VR660	152-0195-00		SEMICONV DEVICE:ZENER,0.4W,5.1V,5%	04713	SZ11755
A5W637	131-0566-00		BUS CONDUCTOR:DUMMY RES,2.375,22 AWG	57668	JWW-0200E0
A5W638	131-0566-00		BUS CONDUCTOR:DUMMY RES,2.375,22 AWG	57668	JWW-0200E0
A5W643	131-0566-00		BUS CONDUCTOR:DUMMY RES,2.375,22 AWG	57668	JWW-0200E0
A5W655	131-0566-00		BUS CONDUCTOR:DUMMY RES,2.375,22 AWG	57668	JWW-0200E0
A5W662	131-0566-00		BUS CONDUCTOR:DUMMY RES,2.375,22 AWG	57668	JWW-0200E0
A5W668	131-0566-00		BUS CONDUCTOR:DUMMY RES,2.375,22 AWG	57668	JWW-0200E0
A5W670	131-0566-00		BUS CONDUCTOR:DUMMY RES,2.375,22 AWG	57668	JWW-0200E0
A5W677	131-0566-00		BUS CONDUCTOR:DUMMY RES,2.375,22 AWG	57668	JWW-0200E0
A5W678	131-0566-00		BUS CONDUCTOR:DUMMY RES,2.375,22 AWG	57668	JWW-0200E0
A5W682	131-0566-00		BUS CONDUCTOR:DUMMY RES,2.375,22 AWG	57668	JWW-0200E0
A5W690	131-0566-00		BUS CONDUCTOR:DUMMY RES,2.375,22 AWG	57668	JWW-0200E0
A5W695	131-0566-00		BUS CONDUCTOR:DUMMY RES,2.375,22 AWG	57668	JWW-0200E0
A5W696	131-0566-00		BUS CONDUCTOR:DUMMY RES,2.375,22 AWG	57668	JWW-0200E0
A5W698	131-0566-00		BUS CONDUCTOR:DUMMY RES,2.375,22 AWG	57668	JWW-0200E0

Replaceable Electrical Parts—2235 Service

Component No.	Tektronix Part No.	Serial/Model No. Eff Dscnt	Name & Description	Mfr Code	Mfr Part Number
A6	670-7615-00		CKT BOARD ASSY:EMI FILTER BOARD	80009	670-7615-00
A6C900	285-1252-00		CAP.,FXD,PLASTIC:0.15UF,10%,250 VAC	26769	719J1MH154PM251S
A6C902	285-1192-00		CAP.,FXD,PPR DI:0.0022UF,20%,250VAC	000FG	PME271Y422
A6C903	285-1192-00		CAP.,FXD,PPR DI:0.0022UF,20%,250VAC	000FG	PME271Y422
A6R901	301-0512-00		RES.,FXD,CMPSN:5.1K OHM,5%,0.50W	01121	EB5125
A6R903	301-0331-00		RES.,FXD,CMPSN:330 OHM,5%,0.50W	01121	EB3315
A6RT901	307-0863-00		RES,THERMAL:100 OHM,10%,NTC	15454	SG13-5
A6T901	120-1449-00		XFMR,COM MODE:	02113	P104
A6T903	120-1455-00		TRANSFORMER,RF:POT CORE	20462	OB0
A6VR901	307-0456-00		RES,V SENSITIVE:	03508	MOV-V250LA15A
A6W9011	196-0531-00		LEAD,ELECTRICAL:18 AWG,3.0 L,8-01	80009	196-0531-00
A6W9091	196-0505-00		LEAD,ELECTRICAL:18 AWG,3.0 L,8-9	80009	196-0505-00
CHASSIS PARTS					
DL9210	119-1515-00		DELAY LINE,ELEC:93NS,150 OHM,ASSY	80009	119-1515-00
F9001	159-0018-00		FUSE,CARTRIDGE:3AG,0.8A,250V,SLOW-BLOW	71400	MDL 8/10
FL9001	119-1541-00		FILTER,RFI:1A,250VAC	05245	1EF1
J9100	131-0126-00		CONNECTOR,RCPT.:BNC,FEMALE	77820	9663-1 NT-34
J9376	131-0955-00		CONN,RCPT,ELEC:BNC,FEMALE	13511	31-279
J9510	131-0126-00		CONNECTOR,RCPT.:BNC,FEMALE	77820	9663-1 NT-34
J9800	131-0955-00		CONN,RCPT,ELEC:BNC,FEMALE	13511	31-279
J9900	136-0387-01		JACK,TIP:BLACK	71279	450-4252-01-0310
R9521	311-2146-00		RES.,VAR,NONWIR:50 OHM,20%,0.5W	12697	CM41773
R9644	311-1183-01		RES.,VAR,WW:PNL,2K OHM,5%,2W	32997	3540S-91-202
R9802A,B	311-2177-00		RES.,VAR,NONWW:PNL,10K OHM,20%,0.5W	12697	CM43517
R9812	311-2177-00		RES.,VAR,NONWW:PNL,10K OHM,20%,0.5W	12697	CM43517
V9870	154-0861-00		ELECTRON TUBE:T4651-31-2	80009	154-0861-00

# DIAGRAMS AND CIRCUIT BOARD ILLUSTRATIONS

## Symbols

Graphic symbols and class designation letters are based on ANSI Standard Y32.2-1975.

Logic symbology is based on ANSI Y32.14-1973 in terms of positive logic. Logic symbols depict the logic function performed and may differ from the manufacturer's data.

The overline on a signal name indicates that the signal performs its intended function when it is in the low state.

Abbreviations are based on ANSI Y1.1-1972.

Other ANSI standards that are used in the preparation of diagrams by Tektronix, Inc. are:

- Y14.15, 1966 Drafting Practices.
- Y14.2, 1973 Line Conventions and Lettering.
- Y10.5, 1968 Letter Symbols for Quantities Used in Electrical Science and Electrical Engineering.

American National Standard Institute  
1430 Broadway  
New York, New York 10018

## Component Values

Electrical components shown on the diagrams are in the following units unless noted otherwise:

- Capacitors = Values one or greater are in picofarads (pF). Values less than one are in microfarads ( $\mu$ F).
- Resistors = Ohms ( $\Omega$ ).

— The information and special symbols below may appear in this manual. —

## Assembly Numbers and Grid Coordinates

Each assembly in the instrument is assigned an assembly number (e.g., A20). The assembly number appears on the circuit board outline on the diagram, in the title for the circuit board component location illustration, and in the lookup table for the schematic diagram and corresponding component locator illustration. The Replaceable Electrical Parts list is arranged by assemblies in numerical sequence; the components are listed by component number \*(see following illustration for constructing a component number).

The schematic diagram and circuit board component location illustration have grids. A lookup table with the grid coordinates is provided for ease of locating the component. Only the components illustrated on the facing diagram are listed in the lookup table. When more than one schematic diagram is used to illustrate the circuitry on a circuit board, the circuit board illustration may only appear opposite the first diagram on which it was illustrated; the lookup table will list the diagram number of other diagrams that the circuitry of the circuit board appears on.

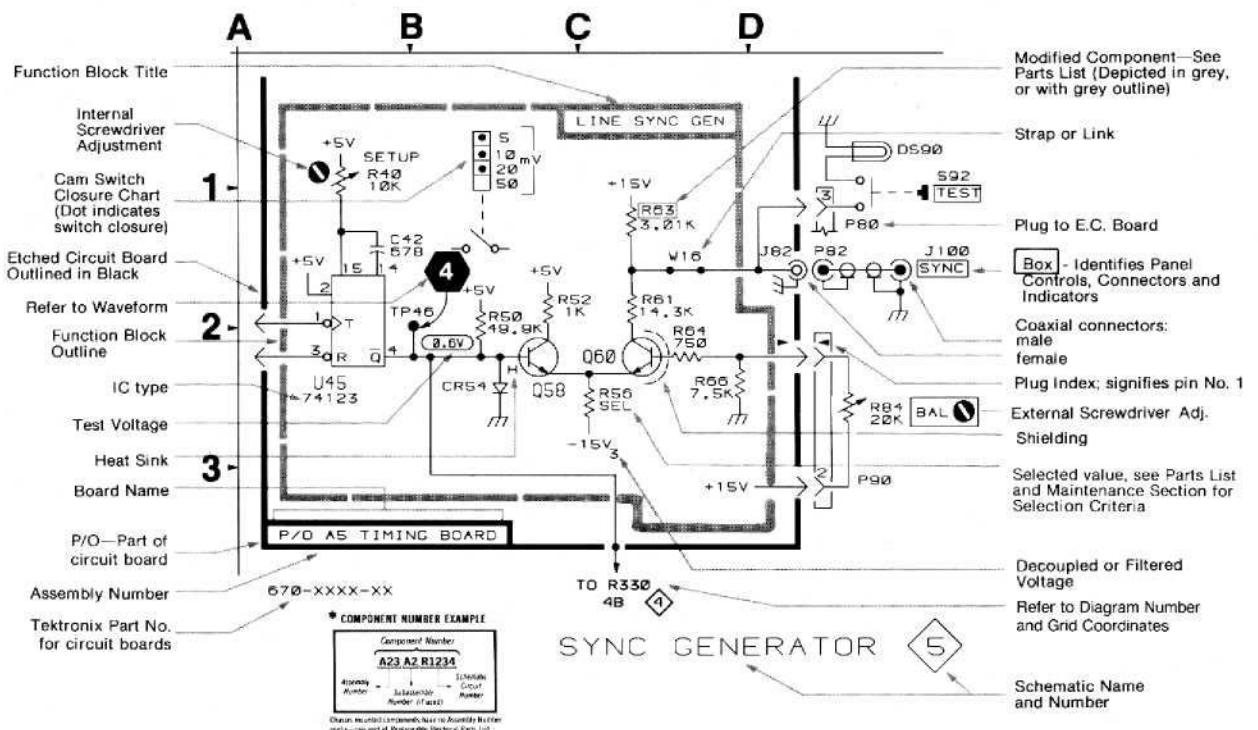

COLOR CODE

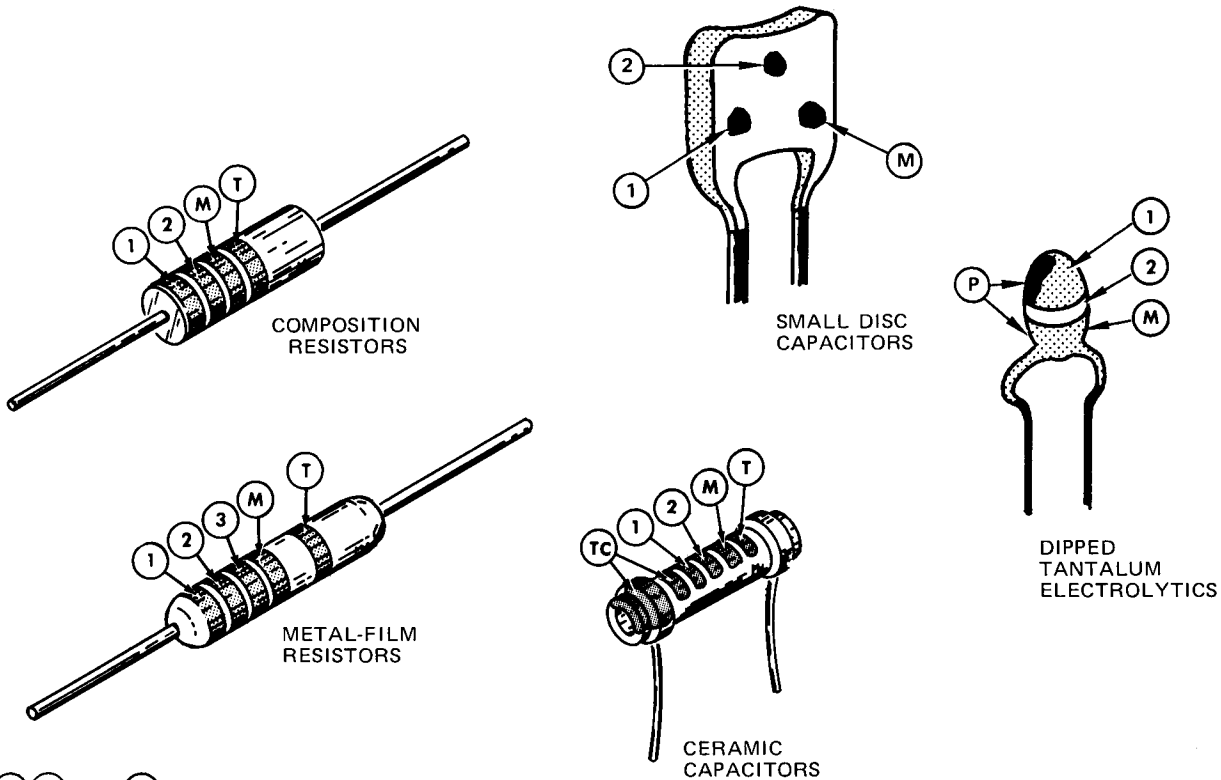

① ② and ③ - 1st, 2nd, and 3rd significant figures

Ⓜ - multiplier      Ⓣ - tolerance

ⓉⓈ - temperature coefficient

Ⓟ - polarity and voltage rating

Ⓣ and/or ⓉⓈ color code may not be present on some capacitors

COLOR	SIGNIFICANT FIGURES	RESISTORS		CAPACITORS			DIPPED TANTALUM VOLTAGE RATING
		MULTIPLIER	TOLERANCE	MULTIPLIER	TOLERANCE		
					over 10 pF	under 10 pF	
BLACK	0	1	----	1	±20%	±2 pF	4 VDC
BROWN	1	10	±1%	10	±1%	±0.1 pF	6 VDC
RED	2	10 <sup>2</sup> or 100	±2%	10 <sup>2</sup> or 100	±2%	----	10 VDC
ORANGE	3	10 <sup>3</sup> or 1 K	±3%	10 <sup>3</sup> or 1000	±3%	----	15 VDC
YELLOW	4	10 <sup>4</sup> or 10 K	±4%	10 <sup>4</sup> or 10,000	+100% -9%	----	20 VDC
GREEN	5	10 <sup>5</sup> or 100 K	±½%	10 <sup>5</sup> or 100,000	±5%	±0.5 pF	25 VDC
BLUE	6	10 <sup>6</sup> or 1 M	±¼%	10 <sup>6</sup> or 1,000,000	----	----	35 VDC
VIOLET	7	----	±1/10%	----	----	----	50 VDC
GRAY	8	----	----	10 <sup>-2</sup> or 0.01	+80% -20%	±0.25 pF	----
WHITE	9	----	----	10 <sup>-1</sup> or 0.1	±10%	±1 pF	----
GOLD	-	10 <sup>-1</sup> or 0.1	±5%	----	----	----	----
SILVER	-	10 <sup>-2</sup> or 0.01	±10%	----	----	----	----
NONE	-	----	±20%	----	±10%	±1 pF	----

Figure 9-1. Color codes for resistors and capacitors.

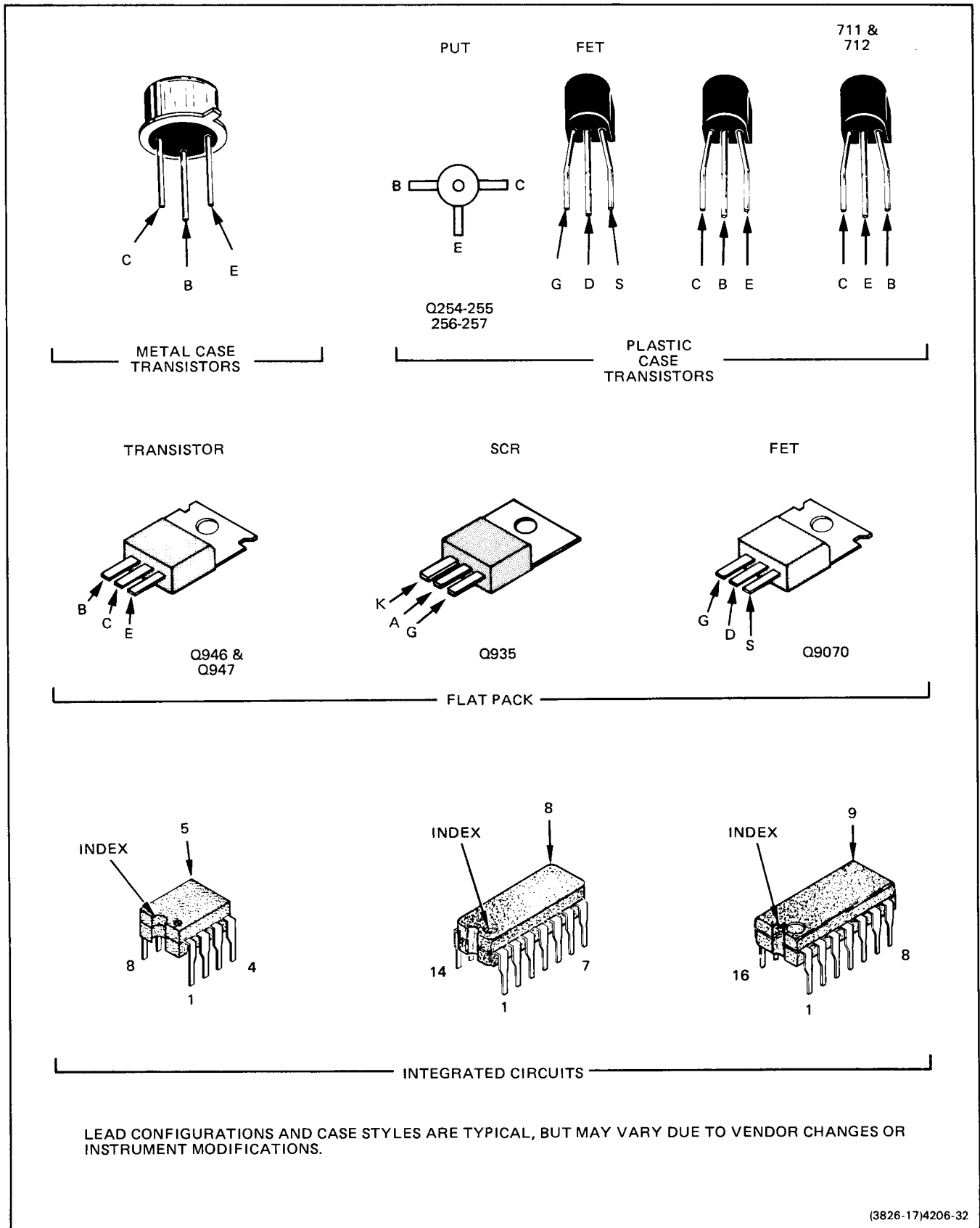

Figure 9-2. Semiconductor lead configurations.

To identify any component mounted on a circuit board and to locate that component in the appropriate schematic diagram

**1. Locate the Circuit Board Illustration**

- a. In the instrument identify the Assembly Number of the circuit board in question. The Assembly Number is usually printed on the upper left corner of the circuit board on the component side.
- b. In the manual locate and pull out tabbed page whose title corresponds with the Assembly Number of the circuit board. Circuit board assembly numbers and board nomenclature are printed on the back side of the tabs (facing the rear of the manual).

**2. Determine the Component Location**

- a. Compare the component location with the desired component location.
- b. Scan the schematic diagram to find the component location.
- c. Determine the component location.

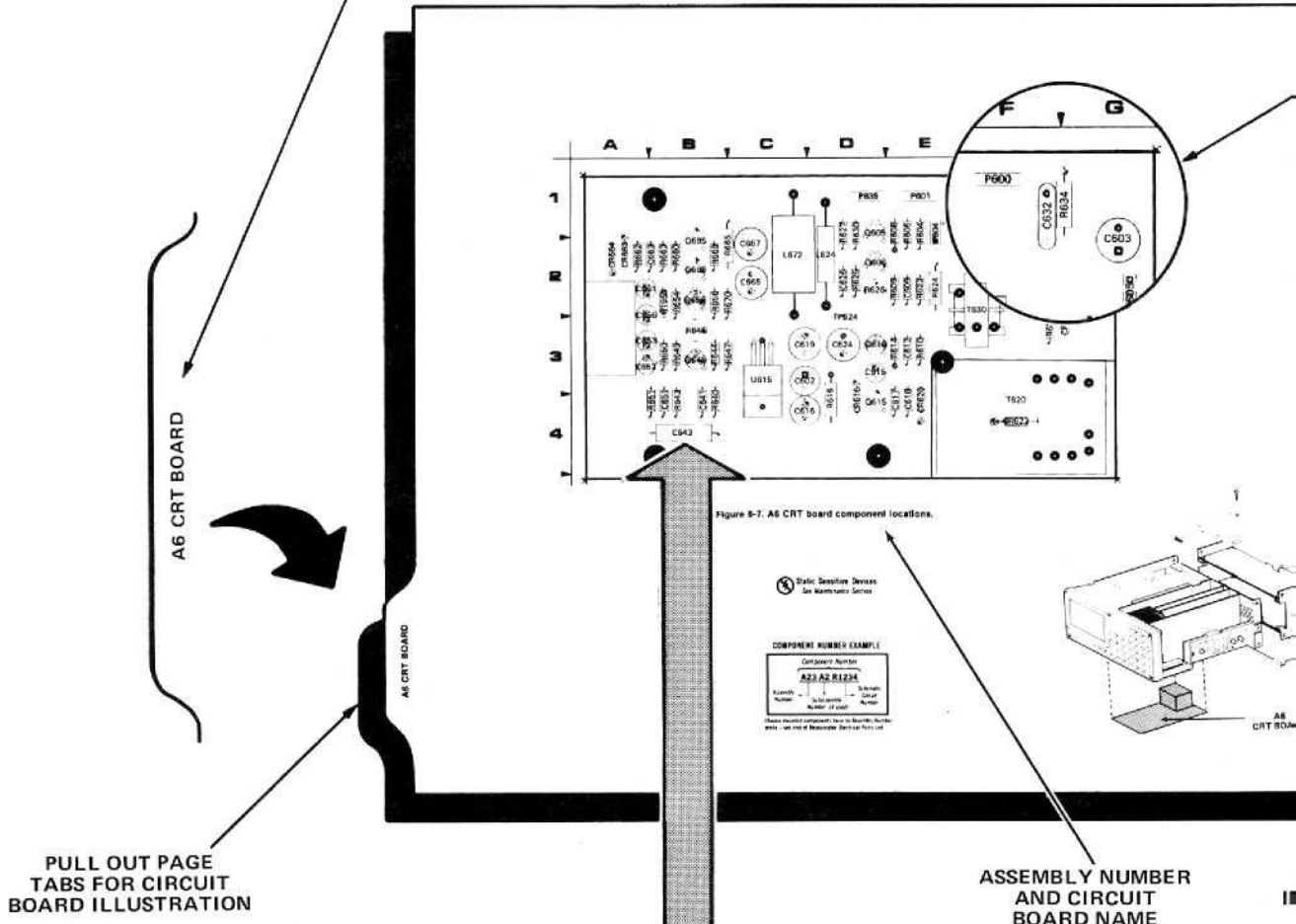

Figure 8-7. A6 CRT board component locations.

**5. Locate the Component on the Circuit Board**

- a. In the manual, locate and pull out the tabbed page whose title and Assembly Number correspond with the desired circuit board. This information is on the back side of the tabs.
- b. Using the Circuit Number and grid coordinates, locate the component on the Circuit Board Illustration.
- c. In the circuit board location illustration, determine the location of the circuit board in the instrument.
- d. Find the circuit board in the instrument and compare it with its illustration in the manual to locate the desired component on the board.

**4. Determine the Circuit Board Illustration Location**

- a. From the schematic diagram, determine the Assembly Number of the circuit board on which the component is mounted. This information is boxed on the back side of the heavy line that distinguishes the board location.
- b. Scan the Component Location Table for the Assembly Number just determined and find the location of the desired component.
- c. Under the BOARD LOCATION column, determine the grid coordinates for the desired component.

Figure 9-3. Locating components on schematic diagram

**Circuit Number**  
 circuit board with its illustration and locate component by area and shape on the illustration.  
 adjacent to the Circuit Board Illustration and Circuit Number of the desired component.  
 the Schematic Diagram Number in which the component is located.

### A6 CRT BOARD

#### COMPONENTS LOCATED ON SCHEMATIC DIAGRAM 10

C602	C632	Q668	R625
C603	C641	R604	R626
C609	C643	R605	R627
C671	C651	R608	R630
C615	Q606	R609	R632
C616	Q610	R610	
C617	Q615	R614	
C618	Q645	R616	
C619	Q656	R623	
C624	Q665	R624	
C626			

#### COMPONENTS LOCATED ON SCHEMATIC DIAGRAM 11

C670	Q670	R677	
C671	Q672	R679	
C673	Q673	R680	
C680			
C681	R671	U617	
P603	R673	U618	
P607	R674	U619	
Q669	R675		

### COMPONENT LOCATION TABLE

CRT CIRCUIT DIAGRAM 10

A6 ASSEMBLY		
CIRCUIT NUMBER	SCHEM LOCATION	BOARD LOCATION
Q606	4E	2D
Q610	7C	3D
Q615	7D	3D
Q645	3E	3B
Q656	2F	2B
Q665	1G	1B
Q668	2G	2B
R604	4C	1E
R605	5D	1E
R608	4E	1D
R609	4E	2D
R610	7B	3E
R614	7C	3D
R616	1C	3D
R623	4D	2E
R625	7F	2D
R626	7F	2D
R627	7G	1D
R630	4E	1D
TP624	3B	2D
U615	1D	3C

CHASSIS MOUNTED PARTS

CIRCUIT NUMBER	SCHEM LOCATION	BOARD LOCATION
L635	51	CHASSIS
V635	6J	CHASSIS

### CRT CIRCUIT DIAGRAM 10

#### A6 ASSEMBLY

CIRCUIT NUMBER	SCHEM LOCATION	BOARD LOCATION	CIRCUIT NUMBER	SCHEM LOCATION	BOARD LOCATION
C602	2C	3C	Q656	2F	2B
C603	1C	1G	Q665	1G	1B
C609	4E	2C	Q668	2G	2B
C612	7C	3E			
C615	7C	3D	R604	4C	1E
C616	2C	3C	R605	5D	1E
C617	7D	3D	R608	4E	1D
C618	7E	3E	R609	4E	2D
C619	6E	3C	R610	7B	3E
C624	4F	3D	R614	7C	3D
C626	7G	2D	R616	1C	3D
C632	8G	1E	R623	4D	2E
C643	3D	4B	R625	7F	2D
C651	3E	3B	R626	7F	2D
		3B	R627	7G	1D
		3B	R630	4E	1D

Q606	4E	2D	TP624	3B	2D
Q610	7C	3D			
Q615	7D	3D	U615	1D	3C
Q645	3E	3B			

#### CHASSIS MOUNTED PARTS

CIRCUIT NUMBER	SCHEM LOCATION	BOARD LOCATION	CIRCUIT NUMBER	SCHEM LOCATION	BOARD LOCATION
L635	51	CHASSIS	V635	6J	CHASSIS

Illustration for Component Circuit Board Location

Component  
 Determine the Assembly in which the component is located in a corner of the board outline.

For the Assembly  
 Determine the Circuit Number of the

man, read the grid

ic diagrams and circuit board illustrations.

MANUAL BINDER

MANUAL BINDER

1  
2  
3  
4

### 3. Locate the Component on the Schematic Diagram

- Locate and pull out tabbed page whose number and title correspond with the Schematic Diagram Number just determined in the table. Schematic diagram nomenclature and numbers are printed on the front side of the tabs (facing the front of the manual).
- Scan the Component Location Table adjacent to the schematic diagram and find the Circuit Number of the desired component.
- Under the SCHEM LOCATION column, read the grid coordinates for the desired component.
- Using the Circuit Number and grid coordinates, locate the component on the schematic diagram.

PULL OUT  
PAGE TABS  
FOR SCHEMATIC  
DIAGRAMS

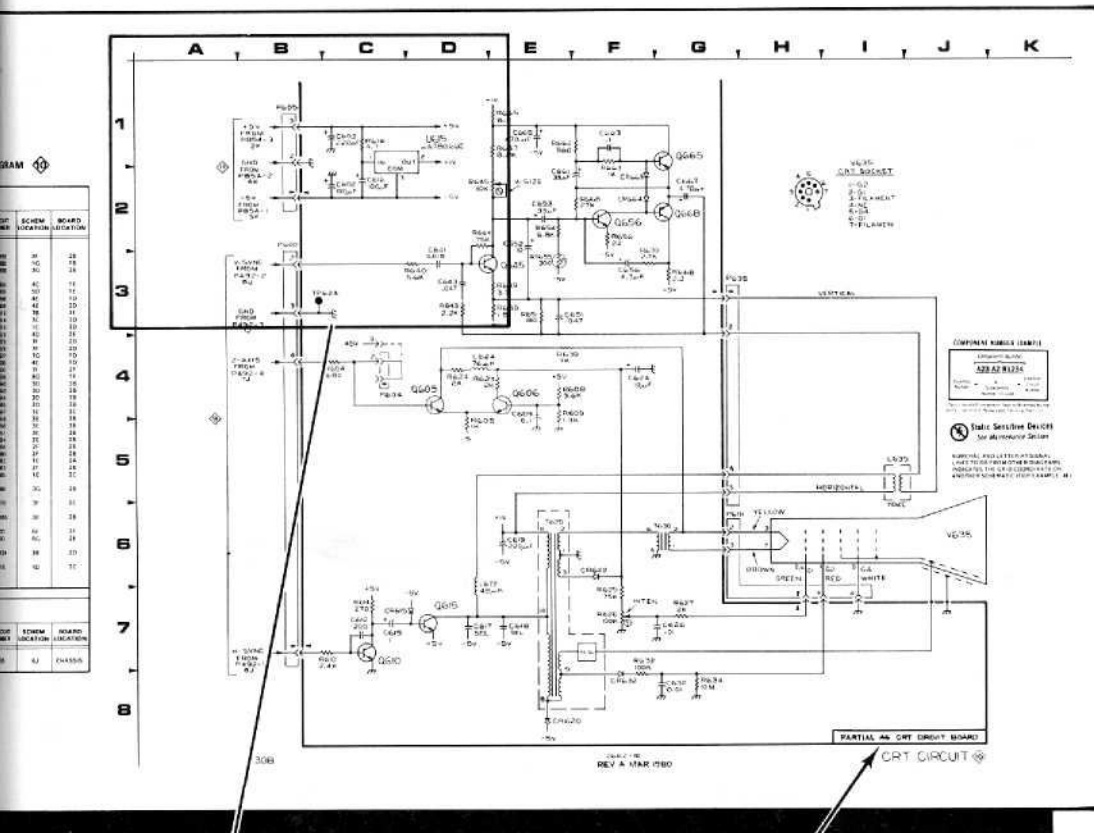

CRT CIRCUIT 10

PARTIAL A6 CRT CIRCUIT BOARD  
CRT CIRCUIT 10

SCHEMATIC DIAGRAM  
NAME AND NUMBER

Numeral and letter at signal lines to or from other diagrams indicates the grid coordinates on another schematic (for example: 4E)

To identify any component in a schematic diagram and to locate that component on its respective circuit board.

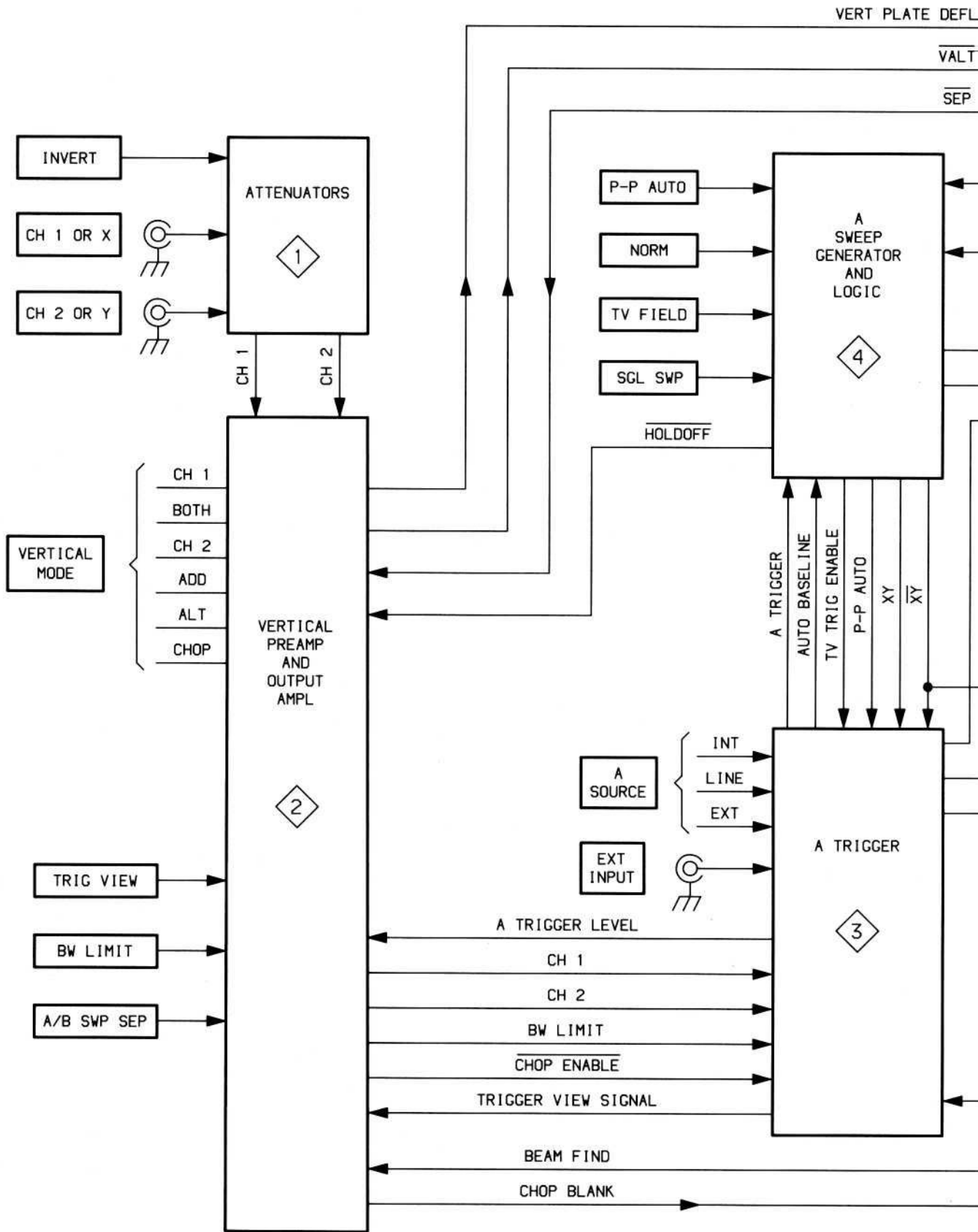
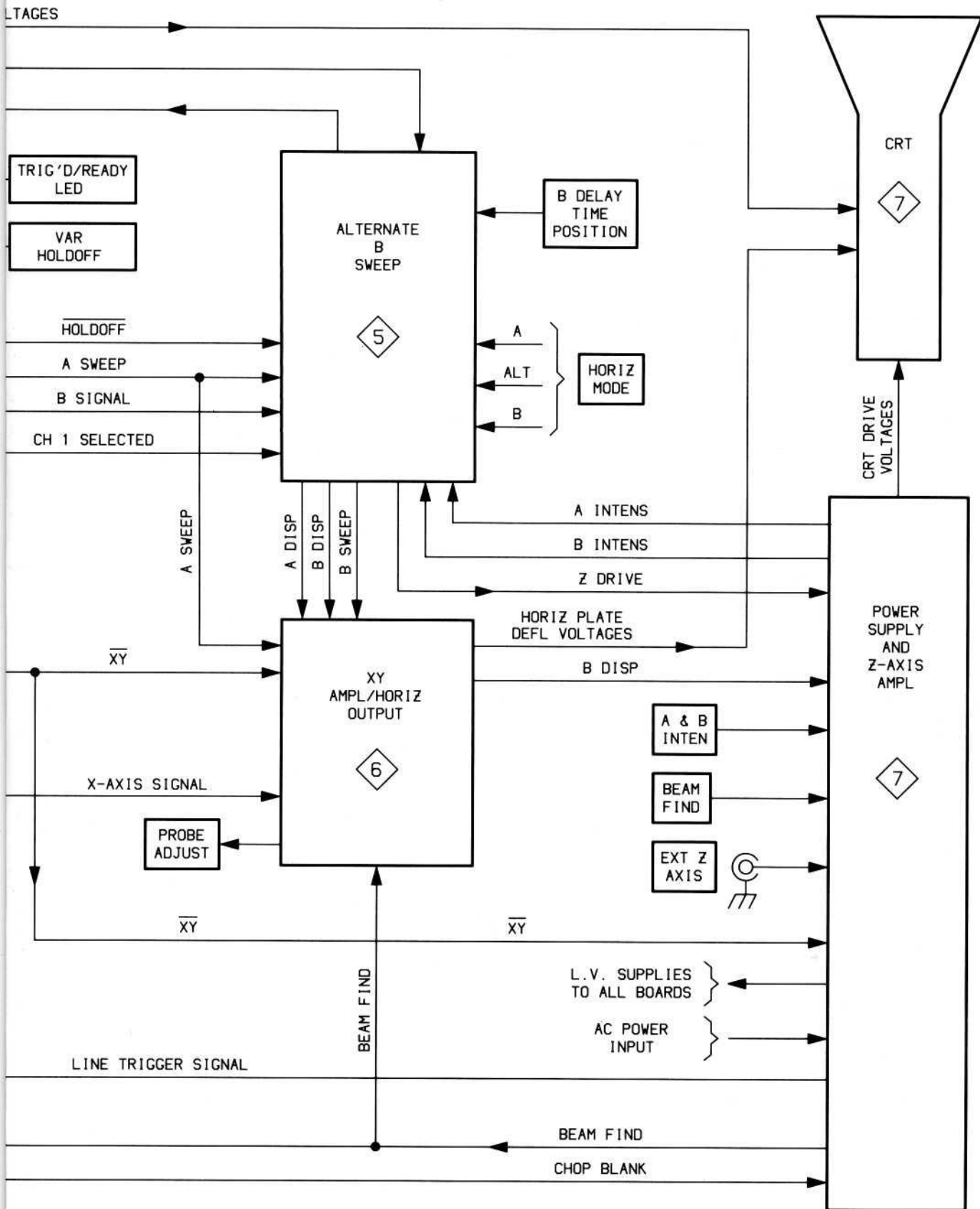

Figure 9



BASIC BLOCK DIAGRAM FIG. 9-4

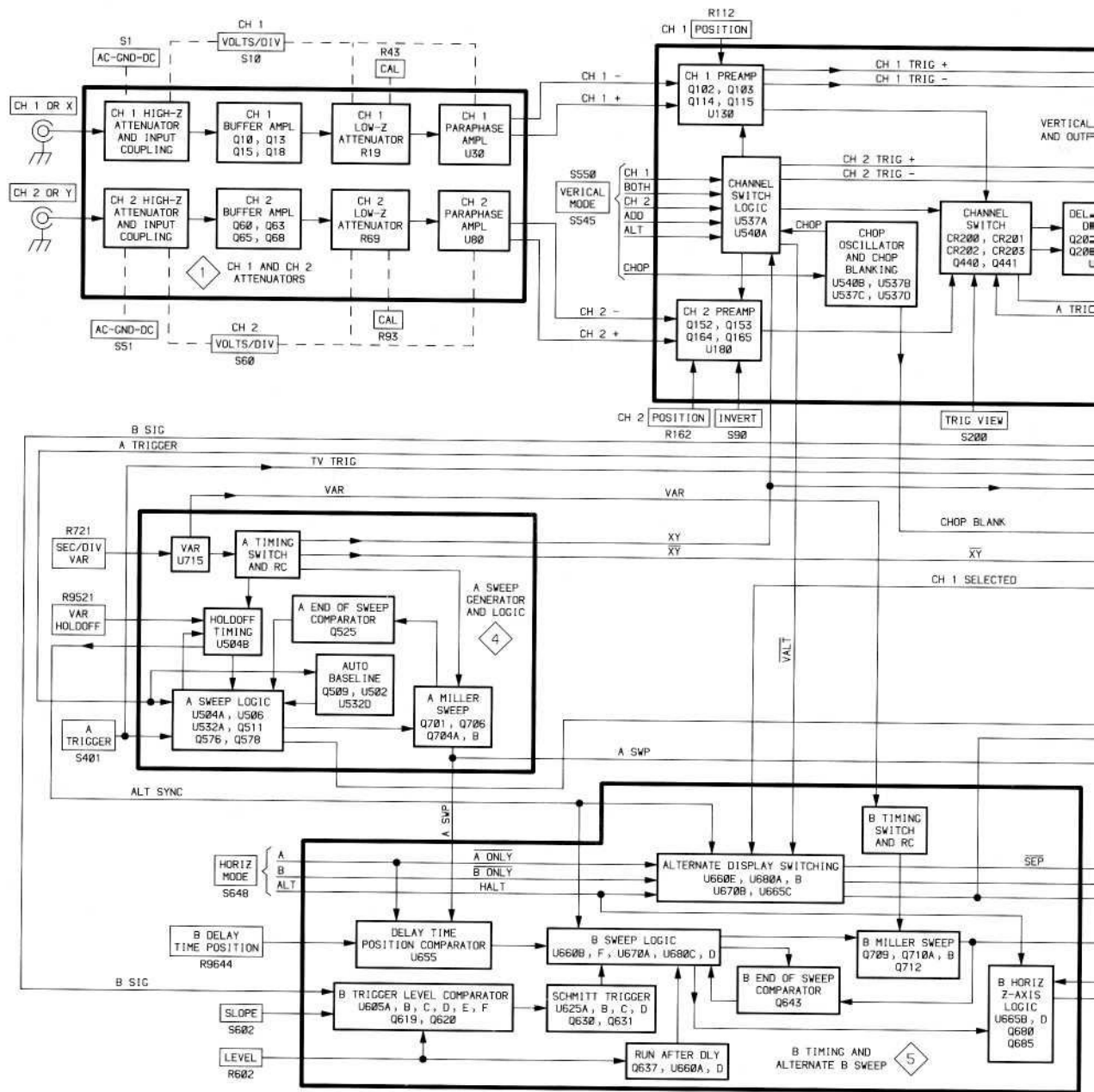
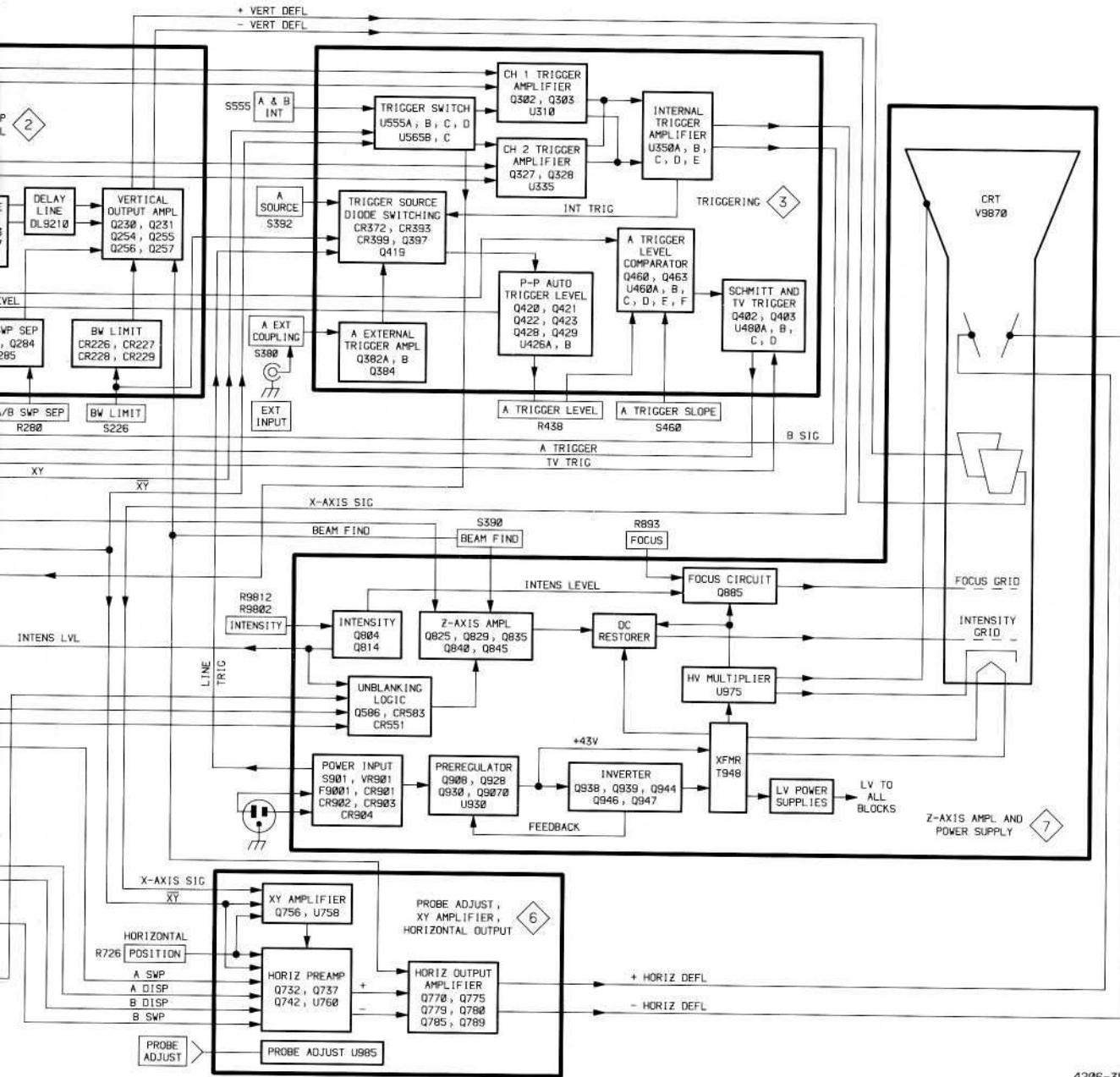

Figure 9-5. D



DETAILED BLOCK DIAGRAM

FIG. 9-5

4206-35

# TEST WAVEFORM AND VOLTAGE SETUPS

## WAVEFORM MEASUREMENTS

On the left-hand pages preceding the schematic diagrams are test waveform illustrations that are intended to aid in troubleshooting the instrument. To test the instrument for these waveforms, make the initial control settings as follows:

### Vertical (Both Channels)

POSITION	Midrange
VERTICAL MODE	CH 1
BW LIMIT	Off (button out)
VOLTS/DIV	10 mV
VOLTS/DIV Variable	CAL detent
INVERT	Off (button out)
AC-GND-DC	GND

### Horizontal

POSITION	Midrange
HORIZONTAL MODE	A
A and B SEC/DIV	0.5 ms
SEC/DIV Variable	CAL detent
X10 Magnifier	Off (knob in)
B DELAY TIME POSITION	5.0

### B TRIGGER

LEVEL	Fully clockwise
SLOPE	OUT

### A TRIGGER

VAR HOLDOFF	Minimum (fully ccw)
Mode	P-P AUTO
LEVEL	Midrange
A&B INT	VERT MODE
A SOURCE	INT

Changes to the control settings for specific waveforms are noted at the beginning of each set of waveforms. Input signals and hookups required are also indicated, if needed, for each set of waveforms.

## DC VOLTAGE MEASUREMENTS

Typical voltage measurements, located on the schematic diagram, were obtained with the instrument operating under the conditions specified in the Waveforms Measurements setup. Control-setting changes required for specific voltages are indicated on each waveforms page. Measurements are referenced to chassis ground with the exception of the Preregulator and Inverter voltages on Diagram 7. These voltages are referenced as indicated on the schematic diagram.

## RECOMMENDED TEST EQUIPMENT

Test equipment in Table 4-1 in the "Performance Check Procedure", section 4 of this manual, meets the required specifications for testing this instrument.

## POWER SUPPLY ISOLATION PROCEDURE

Each regulated supply has numerous feed points to external loads throughout the instrument. The power distribution diagram is used in conjunction with the schematic diagrams to determine those loads that can be isolated by removing service jumpers and those that cannot.

The power distribution and circuit board interconnections diagrams are divided into circuit boards. Each power supply feed to a circuit board is indicated by the schematic diagram number on which the voltage appears. The schematic diagram grid location of a service jumper or component is given adjacent to the component number on the power distribution and circuit board interconnect diagrams.

If a power supply comes up after lifting one of the main jumpers from the power supply to isolate that supply, it is very probable that a short exists in the circuitry on that supply line. By lifting jumpers farther down the line, the circuit in which a short exists may be located.

Always set the POWER switch to OFF before soldering or unsoldering service jumpers or other components and before attempting to measure component resistance values.

### CHASSIS MOUNTED PARTS

CIRCUIT NUMBER	SCHEM NUMBER	SCHEM LOCATION	CIRCUIT NUMBER	SCHEM NUMBER	SCHEM LOCATION
C9272	2	8S	P9870-14	7	8P
C9273	2	2S	P9870-1	7	8P
			P9870-2	7	8N
DL9210	2	5K	P9870-3	7	7N
			P9870-4	7	7N
DS9150	7	8A	P9870-5	7	6P
			P9870-7	7	5P
F9001	7	5A	P9870-8	7	7P
FL9001	7	5A	Q9070	7	8J
J9100	1	1A	R9100	1	1A
J9376	3	5A	R9272	2	8S
J9510	1	6A	R9273	2	2S
J9800	7	4A	R9376	3	5A
J9900	6	2E	R9510	1	6A
			R9521	4	3A
P9272	7	5P	R9644	5	5D
P9273	7	5P	R9802A	7	2A
P9778	7	4P	R9802B	7	3A
P9788	7	4P			
P9070-1	7	8J	V9870	7	2P
P9070-2	7	8J			
P9070-3	7	8J	W9272	2	8S
P9870-10	7	4P			
P9870-12	7	3N			

W9001 (A1 TO A3)					
WIRE NO.	LINE NAME	DIAG NO. & GRID COORDINATES	WIRE NO.	LINE NAME	DIAG NO. & GRID COORDINATES
1	BEAM FIND	7,4F	21	HORIZ POS	6,3B
2	CH 1 POS CW	2,2D	22	+AUTO LEVEL CW	3,8M
3	CH 1 POS CCW	2,3D	23	-AUTO LEVEL CCW	3,8M
4	A/B SWP SEP	2,2L	24	P-P	4,8B
5	+8.6 Vg	8,4P	25	SS RESET	4,5B
6	TRIG VIEW	2,7B	26	B ONLY	5,2E
7	CH 2 POS CW	2,8D	27	HALT	5,2E
8	CH 2 POS CCW	2,9D	28	B SLOPE	5,8F
9	CH 2	2,6B	29	TRIG'D LED	4,9K
10	BW LIMIT	2,4K	30	SS	4,9B
11	CHOP ENABLE	3,4C	31	GND	3,6C
12	-8.6 Vh	8,5P	32	CH 1 T	3,2C
13	VALT	5,2E	33	CH 2 T	3,3C
14	CH 1	2,5B	34	V MODE T	3,3C
15	A ONLY	5,1E	35	EXT	3,7C
16	B LEVEL	5,9F	36	LINE	3,6C
17	TV TRIG ENABLE	4,9B	37	INT	3,7C
18	XY	3,2C	38	GND	3,6C
19	A SLOPE	3,8N	39	EXT INPUT	3,5C
20	A TRIGGER LEVEL	3,8M			

P9700 (A4 TO A1)		
PIN NO.	LINE NAME	DIAG NO. & GRID COORDINATES
1	A DISP	6,5E
2	B DISP	6,5E
3	B SWP	5,6E
4	H.O. 2	4,4D
5	H.O. 1	4,4D
6	H.O. COM	4,4D
7	A SWP	4,8N
8	GND	5,7E
9	B RETRACE	5,7E
10	A GATE	4,7N

W9700 (A1 TO A4)		
WIRE NO.	LINE NAME	DIAG NO. & GRID COORDINATES
1	A DISP	6,5D
2	B DISP	6,5D
3	B SWP	5,6F
4	H.O. 2	4,4D
5	H.O. 1	4,4D
6	H.O. COM	4,4D
7	A SWP	4,8M
8	GND	8,2N
9	B RETRACE	5,6F
10	A GATE	4,7M

W9400 (A1 TO A5)					
WIRE NO.	LINE NAME	DIAG NO. & GRID COORDINATES	WIRE NO.	LINE NAME	DIAG NO. & GRID COORDINATES
1	B SIGNAL	5,9F	15	GND	8,6N
2	B SLOPE	5,9F	16	GND	8,6N
3	GND	8,6N	17	B RETRACE	5,6F
4	B LEVEL	5,9F	18	GND	8,6N
5	A DISP	5,1S	19	VALT	5,2F
6	B ONLY	5,2F	20	A SWP	5,5F
7	SEP	5,2S	21	ALT SYNC	5,1F
8	B INTENSITY LEVEL	7,3C	22	B SWP	5,6F
9	Z DRIVE	7,3E	23	GND	8,6N
10	HALT	5,2F	24	GND	8,6N
11	B DISP	5,2S	25	-8.6 VA	8,6N
12	CH 1 SELECTED	5,2F	26	+5.2 VA	8,5N
13	A ONLY	5,1F	27	+8.6 VA	8,5N
14	DT WIPER	5,5F			

P9705 (A4 TO A1)		
PIN NO.	LINE NAME	DIAG NO. & GRID COORDINATES
1	GND	6,9E
2	+SWP	6,5K
3	-SWP	6,7K
4	GND	6,9E
5	X AXIS SIG	6,4E
6	-8.6 Vc	6,9E
7	+8.6 Vb	6,8E
8	+30 Vb	6,8E

W9705 (A1 TO A4)		
WIRE NO.	LINE NAME	DIAG NO. & GRID COORDINATES
1	GND	8,3N
2	+SWP	6,5L
3	-SWP	6,7L
4	GND	8,3N
5	X AXIS SIG	6,4E
6	-8.6 Vc	8,3N
7	+8.6 Vb	8,3N
8	+30 Vb	8,2N

W9000 (A3 TO A1)					
WIRE NO.	LINE NAME	DIAG NO. & GRID COORDINATES	WIRE NO.	LINE NAME	DIAG NO. & GRID COORDINATES
1	BEAM FIND	7,4F	21	HORIZ POS	6,3B
2	CH 1 POS CW	2,2D	22	+AUTO LEVEL CW	3,8L
3	CH 1 POS CCW	2,3D	23	-AUTO LEVEL CCW	3,9L
4	A/B SWP SEP	2,2L	24	P-P	4,8C
5	+8.6 Vg	8,4N	25	SS RESET	4,5B
6	TRIG VIEW	2,6B	26	B ONLY	5,2E
7	CH 2 POS CW	2,8D	27	HALT	5,2E
8	CH 2 POS CCW	2,9D	28	B SLOPE	5,9E
9	CH 2	2,6B	29	TRIG'D LED	4,9K
10	BW LIMIT	2,4K	30	SS	4,9B
11	CHOP ENABLE	3,4C	31	GND	3,6C
12	-8.6 Vh	8,5N	32	CH 1 T	3,2C
13	VALT	5,2E	33	CH 2 T	3,3C
14	CH 1	2,5B	34	V MODE T	3,3C
15	A ONLY	5,1E	35	EXT	3,7C
16	B LEVEL	5,9E	36	LINE	3,6C
17	TV TRIG ENABLE	4,9B	37	INT	3,7C
18	XY	3,2C	38	GND	3,6C
19	A SLOPE	3,8N	39	EXT INPUT	3,5C
20	A TRIGGER LEVEL	3,8M			

W9401 (A5 TO A1)					
WIRE NO.	LINE NAME	DIAG NO. & GRID COORDINATES	WIRE NO.	LINE NAME	DIAG NO. & GRID COORDINATES
1	B SIGNAL	5,9G	15	GND	5,4G
2	B SLOPE	5,9G	16	GND	5,4G
3	GND	5,4G	17	B RETRACE	5,6G
4	B LEVEL	5,9G	18	GND	5,4G
5	A DISP	5,1S	19	VALT	5,2G
6	B ONLY	5,2G	20	A SWP	5,5G
7	SEP	5,2S	21	ALT SYNC	5,1G
8	B INTENSITY LEVEL	5,4P	22	B SWP	5,6G
9	Z DRIVE	5,5S	23	GND	5,4G
10	HALT	5,2G	24	GND	5,4G
11	B DISP	5,2S	25	-8.6 Va	5,4G
12	CH 1 SELECTED	5,2G	26	+5.2 Va	5,3G
13	A ONLY	5,1G	27	+8.6 Va	5,3G
14	DT WIPER	5,5G			

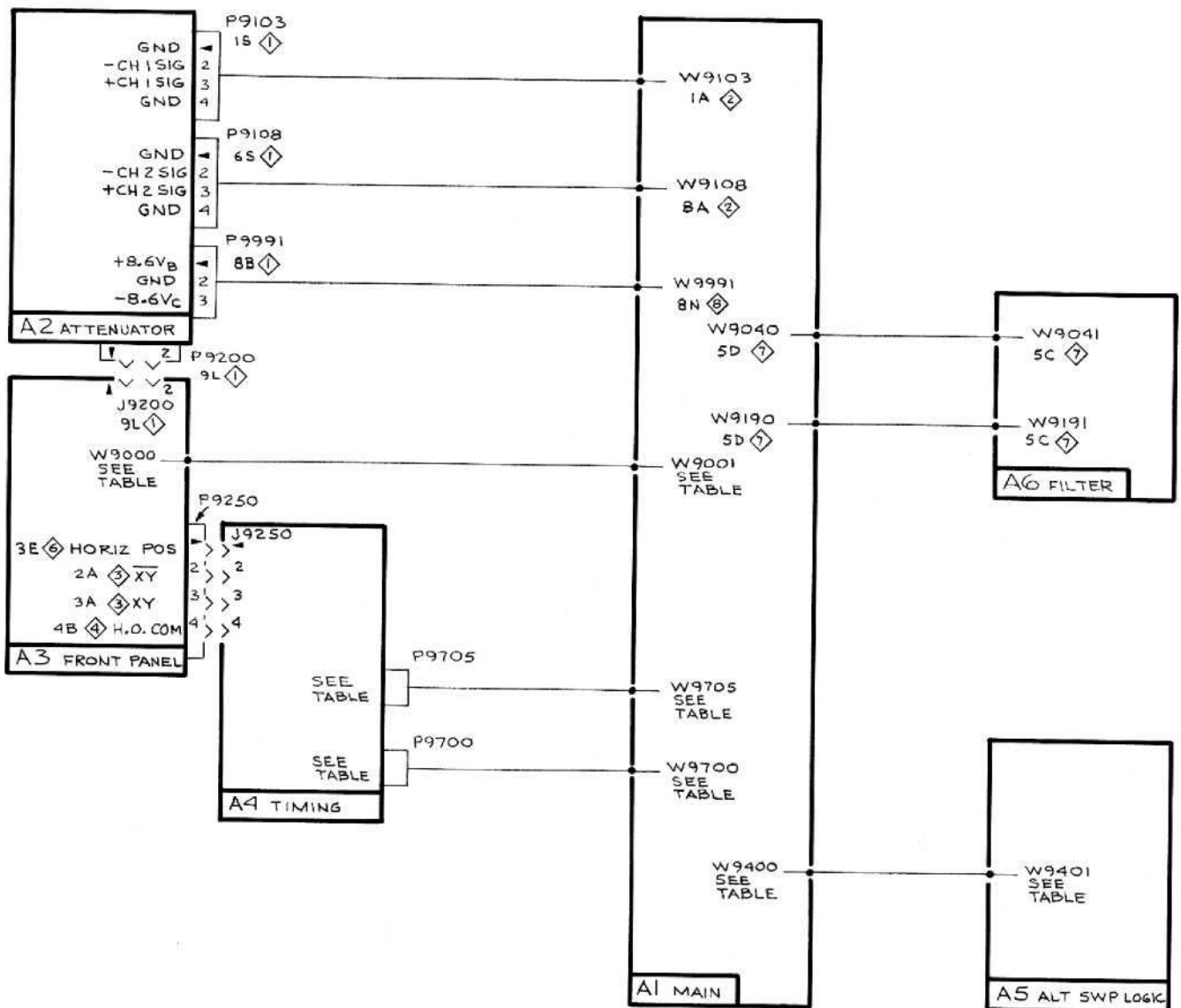

2235

CIRCUIT BOARD INTERCONNECTIONS

4206-22

INTERCONNECTIONS

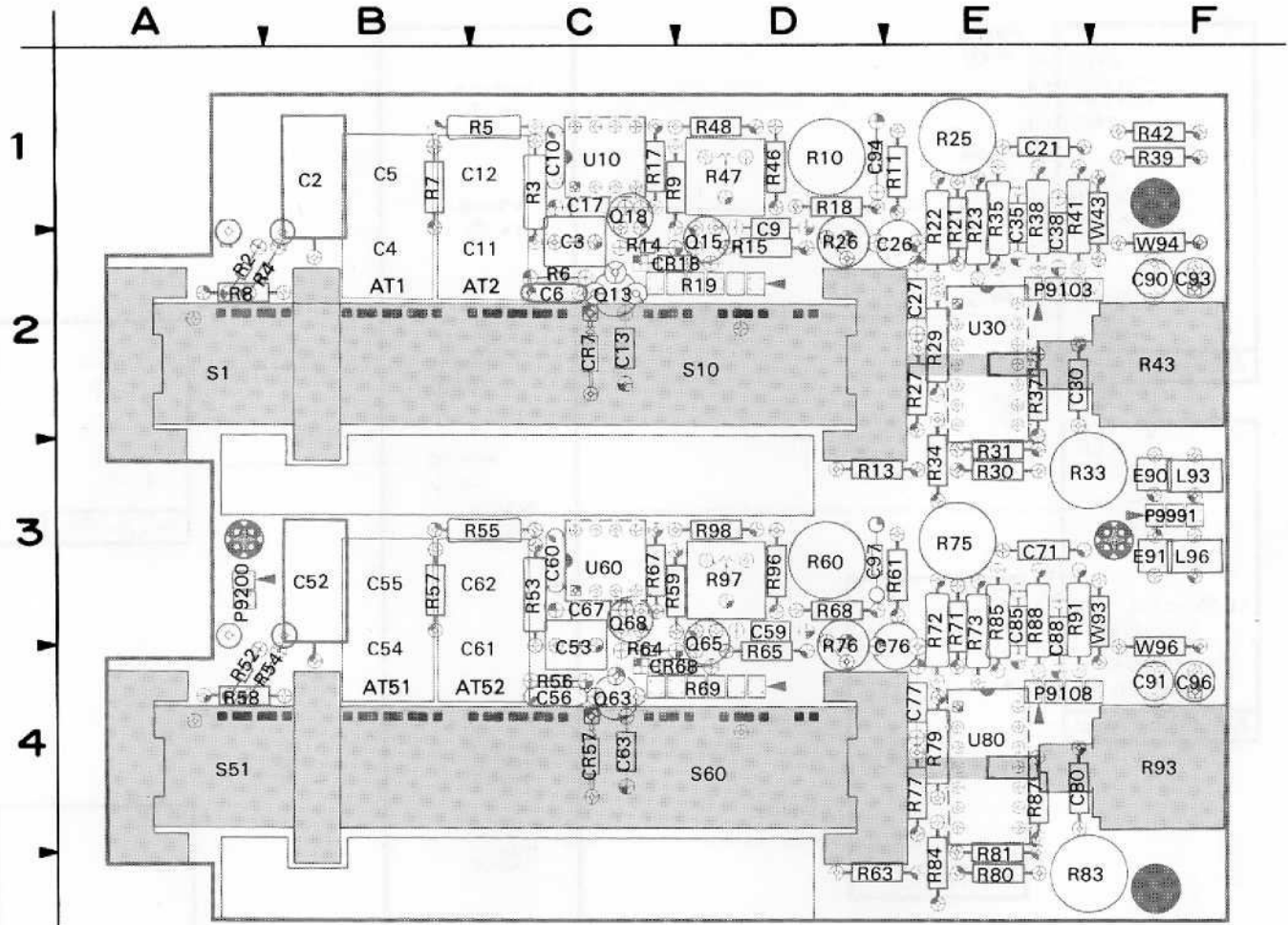

4206-36

Figure 9-6. A2—Attenuator board.

FIG. 9-6

A2-ATTENUATOR BOARD

 Static Sensitive Devices  
See Maintenance Section

COMPONENT NUMBER EXAMPLE

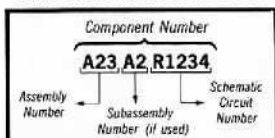

Chassis-mounted components have no Assembly Number prefix—see end of Replaceable Electrical Parts List.

## A2—ATTENUATOR BOARD

CIRCUIT NUMBER	SCHEM NUMBER	CIRCUIT NUMBER	SCHEM NUMBER	CIRCUIT NUMBER	SCHEM NUMBER	CIRCUIT NUMBER	SCHEM NUMBER
AT1	1	C90	1	R8	1	R60	1
AT2	1	C91	1	R9	1	R61	1
AT51	1	C93	1	R10	1	R63	1
AT52	1	C94	1	R11	1	R64	1
C2	1	C96	1	R13	1	R65	1
C3	1	C97	1	R14	1	R67	1
C4	1	CR7	1	R15	1	R68	1
C5	1	CR18	1	R17	1	R69	1
C6	1	CR57	1	R18	1	R71	1
C9	1	CR68	1	R19	1	R72	1
C10	1	E90	1	R21	1	R73	1
C11	1	E91	1	R22	1	R75	1
C12	1	L93	1	R23	1	R76	1
C13	1	L96	1	R25	1	R77	1
C17	1	P9103-1	1	R26	1	R79	1
C21	1	P9103-2	1	R27	1	R80	1
C26	1	P9103-3	1	R29	1	R81	1
C27	1	P9103-4	1	R30	1	R83	1
C30	1	P9108-1	1	R31	1	R84	1
C35	1	P9108-2	1	R33	1	R85	1
C38	1	P9108-3	1	R34	1	R87	1
C52	1	P9108-4	1	R35	1	R88	1
C53	1	P9200-1	1	R37	1	R91	1
C54	1	P9200-2	1	R38	1	R93	1
C55	1	P9991-1	1	R39	1	R96	1
C56	1	P9991-2	1	R41	1	R97	1
C59	1	P9991-3	1	R42	1	R98	1
C60	1	Q13	1	R43	1	S1	1
C61	1	Q15	1	R46	1	S10	1
C62	1	Q18	1	R47	1	S51	1
C63	1	Q63	1	R48	1	S60	1
C67	1	Q65	1	R52	1	U10	1
C71	1	Q68	1	R53	1	U30	1
C76	1	R2	1	R54	1	U60	1
C77	1	R3	1	R55	1	U80	1
C80	1	R4	1	R56	1	W43	1
C85	1	R5	1	R57	1	W93	1
C85	1	R6	1	R58	1	W94	1
C88	1	R7	1	R59	1	W96	1

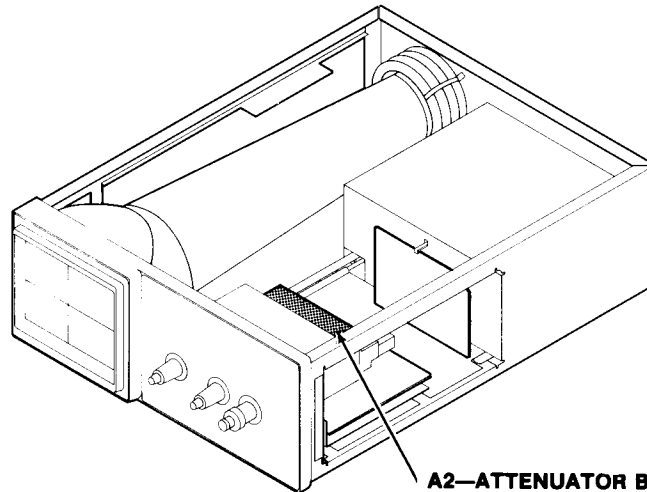

**A2—ATTENUATOR BOARD**

**CIRCUIT BOARD  
INTERCONNECTIONS**

# CH 1 & CH 2 ATTENUATORS



ATTENUATORS

<b>ASSEMBLY A2</b>											
CIRCUIT NUMBER	SCHEM LOCATION	BOARD LOCATION	CIRCUIT NUMBER	SCHEM LOCATION	BOARD LOCATION	CIRCUIT NUMBER	SCHEM LOCATION	BOARD LOCATION	CIRCUIT NUMBER	SCHEM LOCATION	BOARD LOCATION
AT00001	2D	2B	C93	9B	2F	R7	2D	1B	R63	5G	4D
AT2	2E	2C	C94	3H	1D	R8	2B	2A	R64	6G	4C
AT51	6D	4B	C96	9B	4F	R9	2G	1C	R65	7G	4D
AT52	6E	4C	C97	7H	3D	R10	3G	1D	R67	6H	3C
						R11	3G	1E	R68	6H	3D
C2	2B	1B	CR7	1G	2C	R13	1G	3D	R69	6J	4D
C3	2F	2C	CR18	2H	2C	R14	2H	2C	R71	7L	3E
C4	2D	2B	CR57	6G	4C	R15	2G	2D	R72	5L	3E
C5	2D	1B	CR68	6H	4C	R17	1H	1C	R73	5L	3E
C6	1G	2C				R18	2H	1D	R75	5L	3E
C9	2G	2D	E90	8B	3F	R19	1J	2D	R76	7M	3D
C10	3G	1C	E91	8B	3F	R21	3L	1E	R77	7N	4E
C11	2E	2C				R22	3M	1E	R79	7N	4E
C12	2E	1C	L93	9B	3F	R23	2M	1E	R80	7N	4E
C13	1H	2C	L96	9B	3F	R25	2M	1E	R81	8N	4E
C17	2H	1C				R26	3M	2D	R83	8M	4E
C21	2L	1E	P9103-1	2S	2F	R27	2N	2E	R84	8N	4E
C26	3M	2E	P9103-2	2S	2F	R29	2N	2E	R85	9N	3E
C27	3N	2E	P9103-3	3S	2F	R30	3M	3E	R87	8N	4E
C30	3M	2E	P9103-4	3S	2F	R31	3N	3E	R88	9P	3E
C35	5N	1E	P9108-1	7S	4E	R33	3M	3E	R91	9M	3E
C38	4P	1E	P9108-2	6S	4E	R34	4N	3E	R93	9M	4F
C52	6B	3B	P9108-3	8S	4E	R35	5N	1E	R96	7H	3D
C53	6F	3C	P9108-4	7S	4E	R37	4P	2E	R97	8H	3D
C54	6D	4B	P9200-1	9L	3A	R38	4P	1E	R98	8H	3D
C55	6D	3B	P9200-2	9L	3A	R39	4P	1F			
C56	6G	4C	P9991-1	8B	3F	R41	4P	1E	S1	4B	2A
C59	7G	3D	P9991-2	9B	3F	R42	5P	1F	S10	4H	2D
C60	7G	3C	P9991-3	9B	3F	R43	5P	2F	S51	5B	4A
C61	6E	4C				R46	3H	1D	S60	5H	4D
C62	6E	3C	Q13	1H	2C	R47	3H	1D			
C63	6H	4C	Q15	2H	2D	R48	3H	1D	U10	2F	1C
C67	6H	3C	Q18	2H	1C	R52	6A	4A	U30	1N	2E
C71	7L	3E	Q63	6H	4C	R53	6F	3C	U60	6F	3C
C76	7M	3E	Q65	7G	3D	R54	6B	4A	U80	6N	4E
C77	7N	4E	Q68	6H	3C	R55	7F	3C			
C80	8M	4E				R56	6G	4C	W43	5P	1F
C85	9N	3E	R2	2A	2A	R57	6D	3B	W93	9M	3F
C85	9N	3E	R3	2F	1C	R58	6B	4A	W94	9C	2F
C88	9P	3E	R4	2B	2A	R59	7G	3C	W96	9C	4F
C90	8B	2F	R5	2F	1C	R60	7G	3D			
C91	8B	4F	R6	2G	2C	R61	7G	3E			

<b>ASSEMBLY A3</b>											
CIRCUIT NUMBER	SCHEM LOCATION	BOARD LOCATION	CIRCUIT NUMBER	SCHEM LOCATION	BOARD LOCATION	CIRCUIT NUMBER	SCHEM LOCATION	BOARD LOCATION	CIRCUIT NUMBER	SCHEM LOCATION	BOARD LOCATION
J9200-1	9L	3C	R89	9K	2C	S90	9K	2C			
J9200-2	9L	3C	R92	9K	2C						

*Partial A3 also shown on diagrams 2, 3, 4, 5, 6, 7 and 8.*

<b>CHASSIS MOUNTED PARTS</b>											
CIRCUIT NUMBER	SCHEM LOCATION	BOARD LOCATION	CIRCUIT NUMBER	SCHEM LOCATION	BOARD LOCATION	CIRCUIT NUMBER	SCHEM LOCATION	BOARD LOCATION	CIRCUIT NUMBER	SCHEM LOCATION	BOARD LOCATION
J9100	1A	CHASSIS	R9100	1A	CHASSIS						
J9510	6A	CHASSIS	R9510	6A	CHASSIS						

A B C D E F G

1  
2  
3  
4  
5  
6  
7  
8  
9

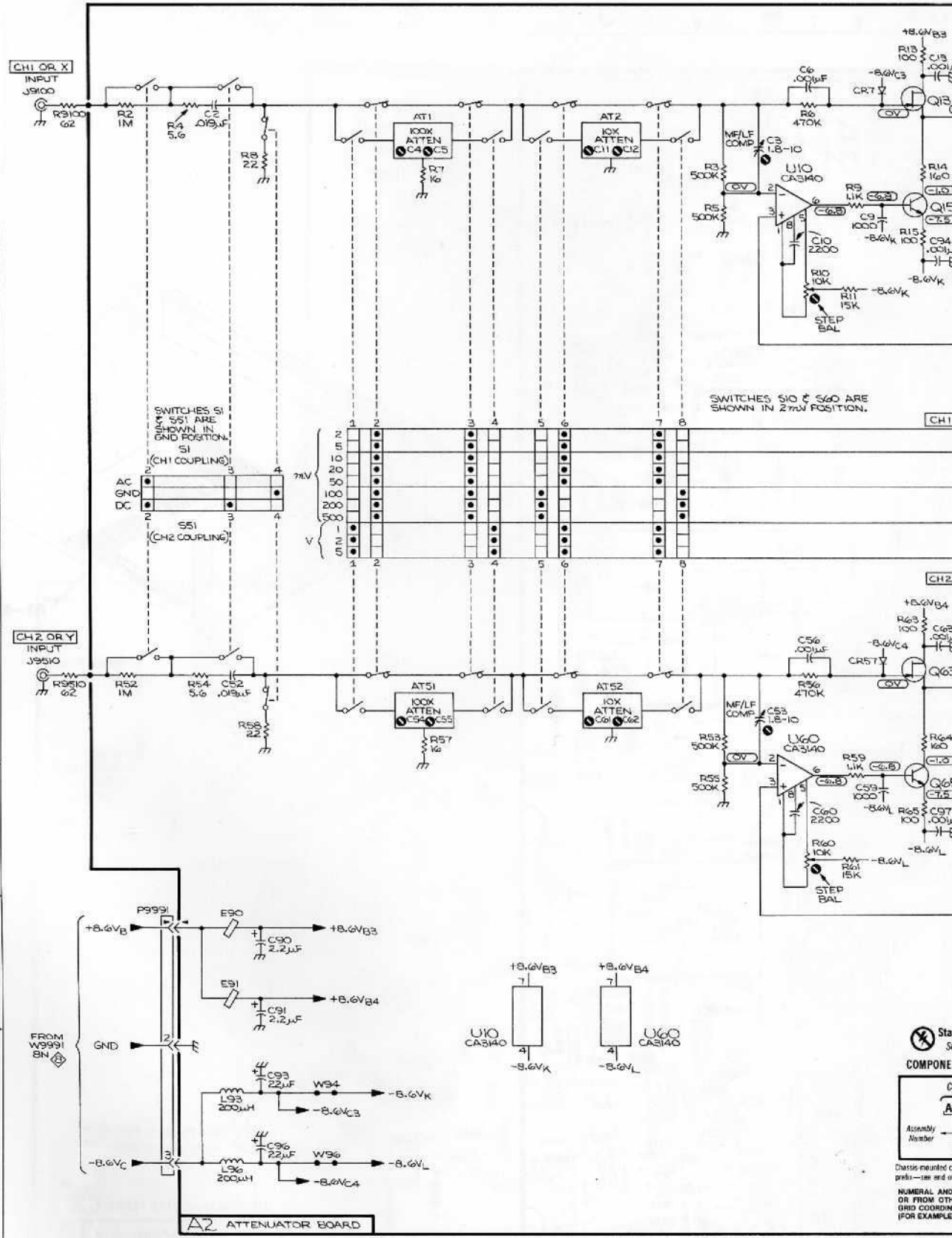

2235

Stat  
COMPEN  
Com  
AZ  
Assembly  
Number  
Chassis mounted components—see end of NUMERAL AND OR FROM OTHER GRID COORDINATE FOR EXAMPLE:

H J K L M N P S

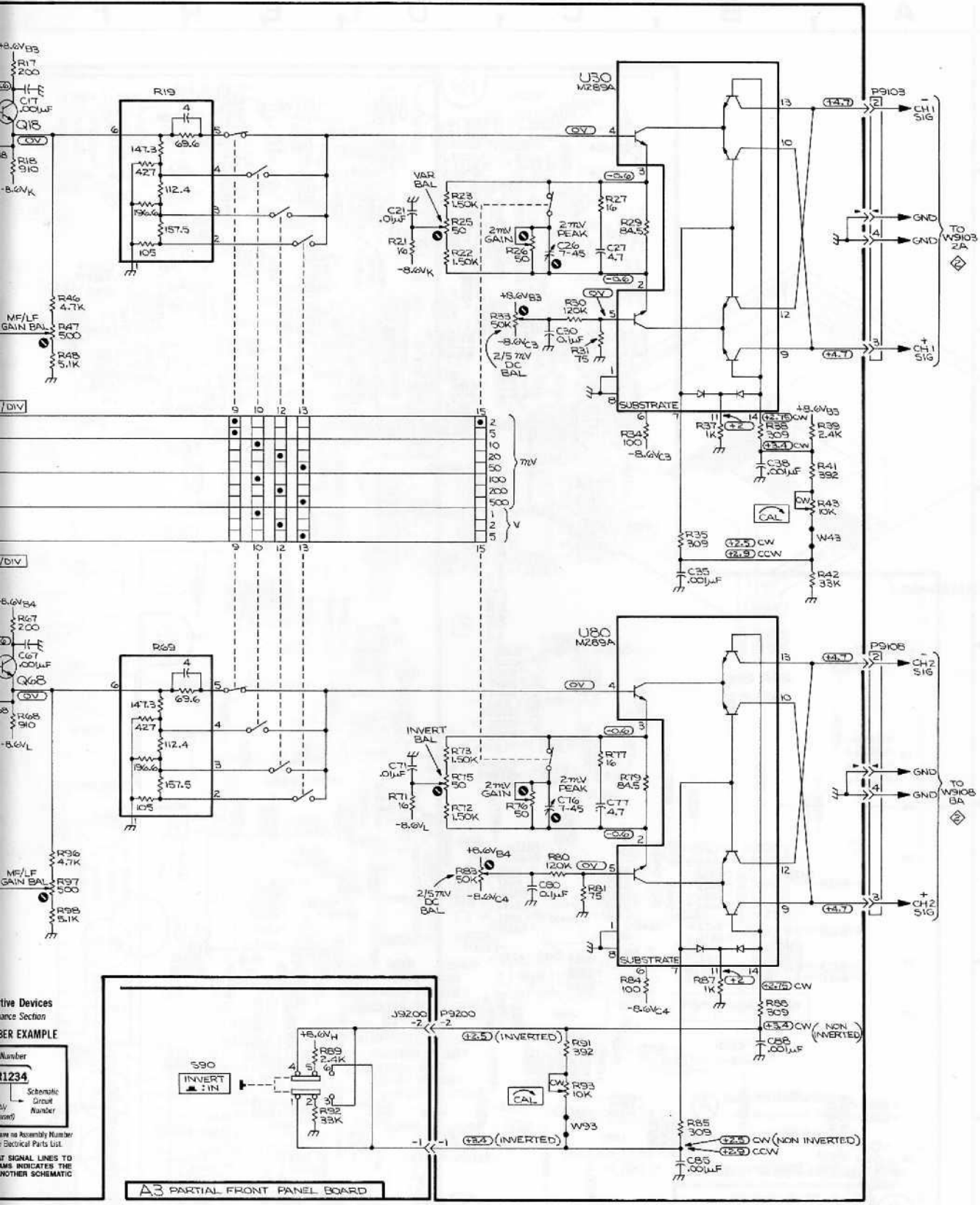

1

Active Devices  
 Reference Section  
 NUMBER EXAMPLE  
 Number  
 11234  
 Schematic  
 Circuit  
 Number  
 11234  
 See the Assembly Number  
 Electrical Parts List.  
 IF SIGNAL LINES TO  
 OTHER SCHEMATICS  
 ARE INDICATED BY  
 OTHER SCHEMATICS

A3 PARTIAL FRONT PANEL BOARD

CH 1 & CH 2 ATTENUATORS 1

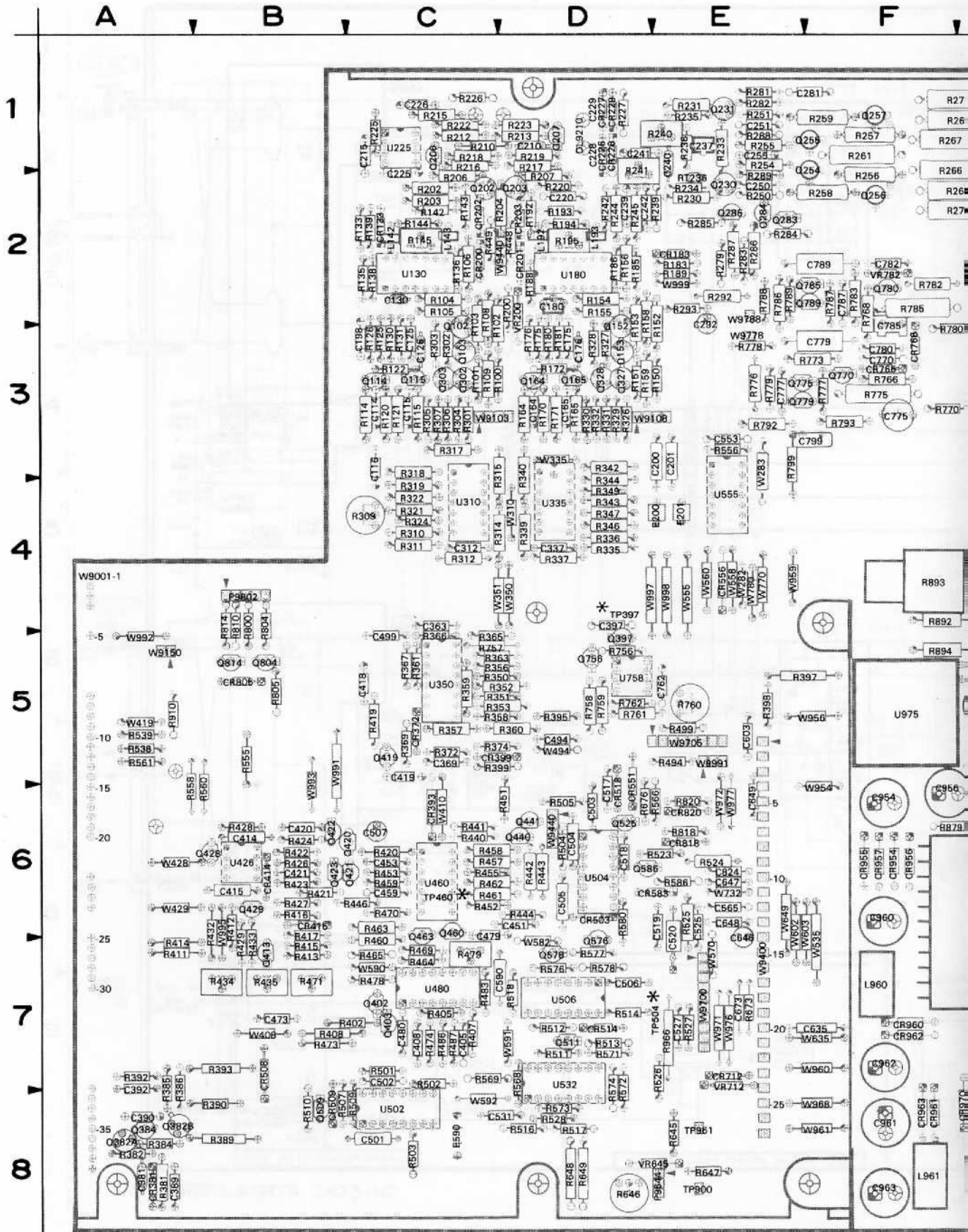

\*These components are located on the reverse side of the circuit board.

Figure 9-7. A1—Main board.

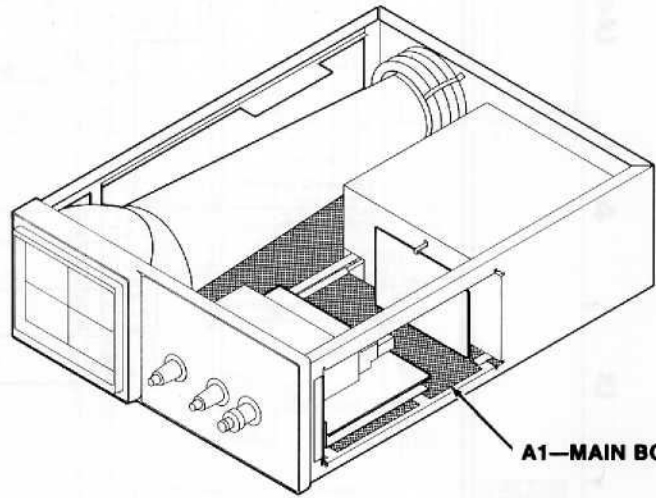
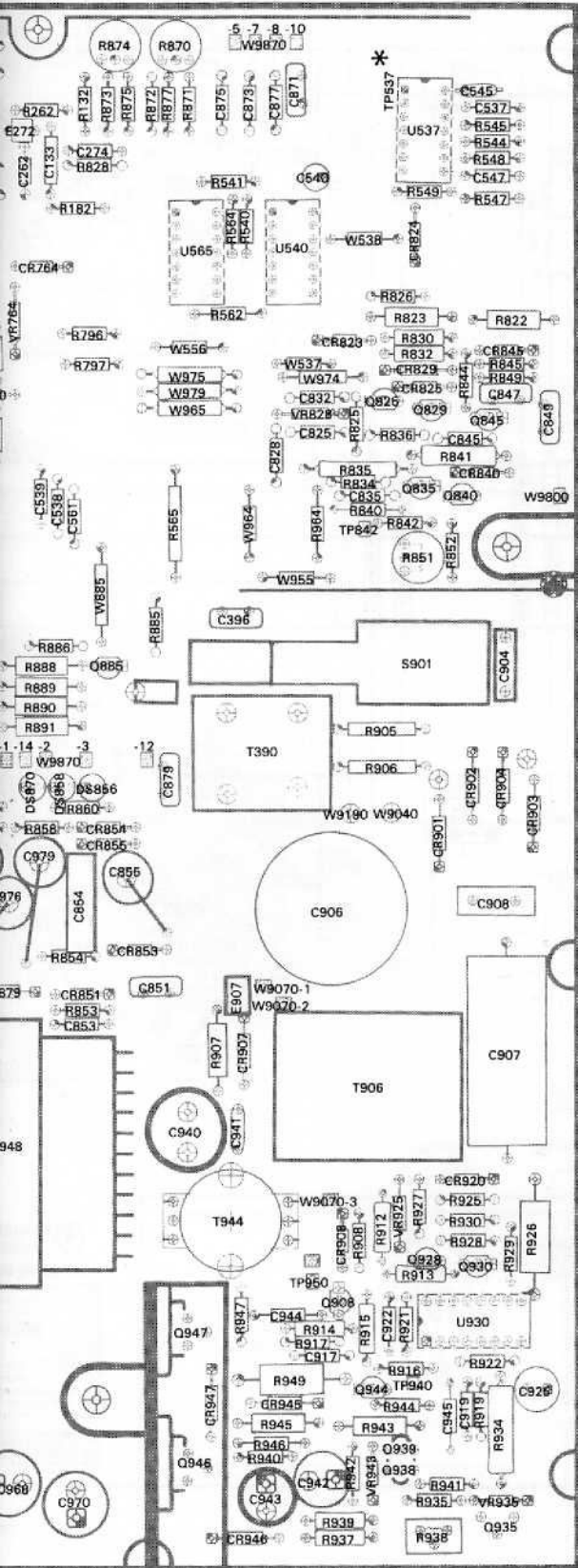

A1—MAIN BOARD

 Static Sensitive Devices  
See Maintenance Section

COMPONENT NUMBER EXAMPLE

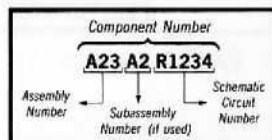

Chassis-mounted components have no Assembly Number prefix—see end of Replaceable Electrical Parts List.

A1—MAIN BOARD

CIRCUIT NUMBER	SCHEM NUMBER	CIRCUIT NUMBER	SCHEM NUMBER	CIRCUIT NUMBER	SCHEM NUMBER	CIRCUIT NUMBER	SCHEM NUMBER	CIRCUIT NUMBER	SCHEM NUMBER	CIRCUIT NUMBER	SCHEM NUMBER
C114	2	C561	3	CR414	3	Q203	2	R131	2	R266	2
C115	2	C565	3	CR415	3	Q206	2	R132	2	R267	2
C116	2	C590	8	CR503	4	Q207	2	R133	2	R268	2
C125	2	C603	5	CR508	4	Q230	2	R135	2	R269	2
C126	2	C635	5	CR509	4	Q231	2	R136	2	R270	2
C130	2	C646	5	CR514	4	Q254	2	R138	2	R271	2
C133	2	C647	5	CR518	4	Q255	2	R139	2	R279	2
C164	2	C648	5	CR551	7	Q256	2	R142	2	R281	2
C165	2	C649	5	CR556	3	Q257	2	R143	2	R282	2
C175	2	C673	5	CR583	7	Q283	2	R144	2	R283	2
C176	2	C762	6	CR712	5	Q284	2	R145	2	R284	2
C180	2	C764	6	CR764	6	Q285	2	R150	2	R285	2
C198	2	C770	6	CR765	6	Q302	3	R151	2	R286	2
C200	8	C775	6	CR768	6	Q303	3	R152	2	R287	2
C201	8	C777	6	CR770	6	Q327	3	R153	2	R288	2
C210	2	C779	6	CR780	6	Q328	3	R154	2	R289	2
C215	2	C780	6	CR805	7	Q382	3	R155	2	R292	2
C220	8	C782	6	CR818	7	Q382	3	R156	2	R293	2
C225	2	C785	6	CR820	7	Q384	3	R158	2	R301	3
C226	2	C787	6	CR823	7	Q397	3	R159	2	R302	3
C228	2	C789	6	CR824	7	Q402	3	R164	2	R303	3
C229	2	C796	8	CR825	7	Q403	3	R165	2	R304	3
C237	2	C797	8	CR829	7	Q413	3	R170	2	R305	3
C239	2	C799	8	CR840	7	Q419	3	R171	2	R306	3
C240	2	C824	7	CR845	7	Q420	3	R172	2	R307	3
C241	2	C825	7	CR851	7	Q421	3	R175	2	R309	3
C242	2	C828	7	CR853	7	Q422	3	R176	2	R310	3
C250	2	C832	7	CR854	7	Q423	3	R180	2	R311	3
C251	2	C835	7	CR855	7	Q428	3	R181	2	R312	3
C255	2	C845	7	CR879	7	Q429	3	R182	2	R314	3
C262	2	C847	7	CR901	7	Q440	2	R183	2	R315	3
C274	8	C849	7	CR902	7	Q441	2	R185	2	R317	3
C281	2	C851	7	CR903	7	Q460	3	R186	2	R318	3
C292	2	C853	7	CR904	7	Q463	3	R188	2	R319	3
C312	3	C854	7	CR907	7	Q509	4	R189	2	R321	3
C337	3	C855	7	CR908	7	Q511	4	R192	2	R322	3
C363	3	C871	7	CR920	7	Q525	4	R193	2	R324	3
C369	3	C873	7	CR945	7	Q576	4	R194	2	R326	3
C381	3	C875	7	CR946	7	Q578	4	R195	2	R327	3
C389	3	C877	7	CR947	7	Q586	7	R200	2	R328	3
C390	3	C879	7	CR954	7	Q756	6	R202	2	R329	3
C392	3	C893	7	CR955	7	Q770	6	R203	2	R330	3
C396	7	C904	7	CR956	7	Q775	6	R204	2	R331	3
C397	3	C906	7	CR957	7	Q779	6	R206	2	R332	3
C405	3	C907	7	CR960	7	Q780	6	R207	2	R335	3
C408	3	C908	7	CR961	7	Q785	6	R210	2	R336	3
C414	3	C917	7	CR962	7	Q789	6	R212	2	R337	3
C415	3	C919	7	CR963	7	Q804	7	R213	2	R339	3
C418	3	C922	7	CR967	7	Q814	7	R215	2	R340	3
C419	3	C925	7	CR970	7	Q825	7	R216	2	R342	3
C420	3	C940	7	DS856	7	Q829	7	R217	2	R343	3
C421	3	C941	7	DS858	7	Q835	7	R218	2	R344	3
C451	8	C942	7	DS870	7	Q840	7	R219	2	R346	3
C453	3	C943	7	E200	8	Q845	7	R220	8	R347	3
C459	3	C944	7	E201	8	Q885	7	R222	2	R349	3
C473	3	C945	7	E272	8	Q908	7	R223	2	R350	3
C479	3	C954	7	E590	8	Q928	7	R225	2	R351	3
C480	3	C956	7	E907	7	Q930	7	R226	2	R352	3
C494	8	C960	7	L142	2	Q935	7	R227	2	R353	3
C499	8	C961	7	L143	2	Q938	7	R230	2	R356	3
C501	4	C962	7	L192	2	Q939	7	R231	2	R357	3
C502	4	C963	7	L193	2	Q944	7	R233	2	R358	3
C503	4	C968	7	L960	7	Q946	7	R234	2	R359	3
C504	4	C970	7	L961	7	Q947	7	R235	2	R360	3
C505	4	C975	7	P9644-1	5	R100	2	R236	2	R361	3
C506	4	C976	7	P9644-2	5	R101	2	R239	2	R363	3
C507	8	C979	7	P9644-3	5	R102	2	R240	2	R365	3
C517	4	CR133	2	P9802-1	7	R103	2	R241	2	R366	3
C518	4	CR183	2	P9802-2	7	R104	2	R242	2	R367	3
C519	4	CR200	2	P9802-3	7	R105	2	R244	2	R369	3
C520	4	CR201	2	P9802-4	7	R106	2	R245	2	R372	3
C525	4	CR202	2	P9802-5	7	R108	2	R250	2	R374	3
C527	4	CR203	2	Q102	2	R109	2	R251	2	R381	3
C531	4	CR226	2	Q103	2	R114	2	R254	2	R382	3
C537	2	CR227	2	Q114	2	R115	2	R255	2	R384	3
C538	2	CR228	2	Q115	2	R120	2	R256	2	R385	3
C539	2	CR229	2	Q152	2	R121	2	R257	2	R386	3
C540	2	CR372	3	Q153	2	R122	2	R258	2	R389	3
C545	2	CR381	3	Q164	2	R125	2	R259	2	R390	3
C547	2	CR393	3	Q165	2	R126	2	R261	2	R392	3
C553	3	CR399	3	Q202	2	R130	2	R262	2	R393	3



**A1—MAIN BOARD (cont)**

CIRCUIT NUMBER	SCHEM NUMBER	CIRCUIT NUMBER	SCHEM NUMBER	CIRCUIT NUMBER	SCHEM NUMBER	CIRCUIT NUMBER	SCHEM NUMBER	CIRCUIT NUMBER	SCHEM NUMBER	CIRCUIT NUMBER	SCHEM NUMBER
R395	3	R527	4	R832	7	TP537	2	W570	6	W9070-2	7
R397	7	R528	4	R834	7	TP842	7	W582	4	W9070-3	7
R398	7	R538	2	R835	7	TP900	7	W590	8	W9103-1	2
R399	3	R539	2	R836	7	TP940	7	W591	8	W9103-2	2
R402	3	R540	2	R840	7	TP950	7	W592	8	W9103-3	2
R405	3	R541	2	R841	7	TP961	8	W602	5	W9103-4	2
R407	3	R544	2	R842	7	U130	2	W603	5	W9108-1	2
R408	3	R545	2	R844	7	U180	2	W635	5	W9108-2	2
R411	3	R547	2	R845	7	U225	2	W649	5	W9108-3	2
R412	3	R548	2	R849	7	U310	3	W732	6	W9108-4	2
R413	3	R549	2	R851	7	U335	3	W770	6	W9150-1	7
R414	3	R555	3	R852	7	U350	3	W780	6	W9150-2	7
R415	3	R556	3	R853	7	U350	3	W885	8	W9400-10	5
R416	3	R558	3	R854	7	U350	3	W954	8	W9400-11	5
R417	3	R560	3	R858	7	U350	3	W955	8	W9400-12	5
R419	3	R561	3	R860	7	U350	3	W956	8	W9400-13	5
R420	3	R562	3	R870	7	U426	3	W959	8	W9400-14	5
R421	3	R564	3	R871	7	U426	3	W960	8	W9400-15	8
R422	3	R565	3	R872	7	U460	3	W961	8	W9400-16	8
R423	3	R566	6	R873	7	U460	3	W964	8	W9400-17	5
R424	3	R568	4	R874	7	U460	3	W965	8	W9400-18	8
R426	3	R569	4	R875	7	U460	3	W968	8	W9400-19	5
R427	3	R571	4	R877	7	U460	3	W971	8	W9400-1	5
R428	3	R572	4	R879	7	U460	3	W972	8	W9400-20	5
R429	3	R573	4	R885	7	U480	3	W974	8	W9400-21	5
R432	3	R574	4	R886	7	U480	3	W975	8	W9400-22	5
R433	3	R576	4	R888	7	U480	3	W976	8	W9400-23	8
R434	3	R577	4	R889	7	U480	3	W977	8	W9400-24	8
R435	3	R578	4	R890	7	U502	4	W979	8	W9400-25	8
R440	2	R580	4	R891	7	U504	4	W991	8	W9400-26	8
R441	2	R586	7	R892	7	U504	4	W992	8	W9400-27	8
R442	2	R645	5	R893	7	U506	4	W993	8	W9400-2	5
R443	2	R646	5	R894	7	U506	4	W995	8	W9400-3	8
R444	2	R647	5	R905	7	U532	4	W997	8	W9400-4	5
R446	3	R648	5	R906	7	U532	4	W998	8	W9400-5	5
R448	2	R649	5	R907	7	U532	4	W999	8	W9400-6	5
R449	2	R673	5	R908	7	U532	4	W9040	7	W9400-7	5
R451	8	R676	6	R910	7	U537	2	W9190	7	W9400-8	7
R452	3	R756	6	R912	7	U537	2	W9778	6	W9400-9	7
R453	3	R757	6	R913	7	U537	2	W9788	6	W9440-1	2
R455	3	R758	6	R914	7	U537	2	W9800	7	W9440-2	2
R457	3	R759	6	R915	7	U540	2	W9001-10	2	W9440-3	2
R458	3	R760	6	R916	7	U540	2	W9001-11	3	W9440-4	2
R459	3	R761	6	R917	7	U555	3	W9001-12	8	W9700-10	4
R460	3	R762	6	R919	7	U555	3	W9001-13	5	W9700-1	6
R461	3	R764	6	R921	7	U555	3	W9001-14	2	W9700-2	6
R462	3	R766	6	R922	7	U555	3	W9001-15	5	W9700-3	5
R463	3	R768	6	R925	7	U565	3	W9001-16	5	W9700-4	4
R464	3	R770	6	R926	7	U565	3	W9001-17	4	W9700-5	4
R465	3	R773	6	R927	7	U565	3	W9001-18	3	W9700-6	4
R469	3	R775	6	R928	7	U758	6	W9001-19	3	W9700-7	4
R470	3	R776	6	R929	7	U930	7	W9001-1	7	W9700-8	8
R471	3	R777	6	R930	7	U975	7	W9001-20	3	W9700-9	5
R473	3	R778	6	R934	7	VR200	2	W9001-21	6	W9705-1	8
R474	3	R779	6	R935	7	VR645	5	W9001-22	3	W9705-2	6
R478	3	R780	6	R937	7	VR712	5	W9001-23	3	W9705-3	6
R479	3	R782	6	R938	7	VR764	6	W9001-24	4	W9705-4	8
R483	3	R783	6	R939	7	VR782	6	W9001-25	4	W9705-5	6
R486	3	R785	6	R940	7	VR828	7	W9001-26	5	W9705-6	8
R487	3	R786	6	R941	7	VR925	7	W9001-27	5	W9705-7	8
R494	8	R787	6	R942	7	VR935	7	W9001-28	5	W9705-8	8
R499	8	R788	6	R943	7	VR943	7	W9001-29	4	W9870-10	7
R501	4	R789	6	R944	7	W282	2	W9001-2	2	W9870-12	7
R502	4	R792	6	R945	7	W283	2	W9001-30	4	W9870-14	7
R503	4	R793	6	R946	7	W310	3	W9001-31	3	W9870-1	7
R504	4	R796	8	R947	7	W335	3	W9001-32	3	W9870-2	7
R505	4	R797	8	R949	7	W350	3	W9001-33	3	W9870-3	7
R507	4	R799	8	R964	8	W351	3	W9001-34	3	W9870-4	7
R509	4	R800	7	R966	8	W408	8	W9001-35	3	W9870-5	7
R510	4	R804	7	R971	7	W410	3	W9001-36	3	W9870-7	7
R511	4	R805	7	R976	7	W419	3	W9001-37	3	W9870-8	7
R512	4	R810	7	R978	7	W428	3	W9001-38	3	W9991-1	8
R513	4	R814	7	RT236	2	W429	3	W9001-39	3	W9991-2	8
R514	4	R818	7	S901	7	W494	8	W9001-3	2	W9991-3	8
R516	4	R820	7	T390	7	W535	2	W9001-4	2		
R517	4	R822	7	T906	7	W537	2	W9001-5	8		
R518	4	R823	7	T944	7	W538	2	W9001-6	2		
R523	4	R825	7	T948	7	W555	3	W9001-7	2		
R524	4	R826	7	TP397	3	W556	8	W9001-8	2		
R525	4	R828	7	TP460	3	W558	3	W9001-9	2		
R526	4	R830	7	TP504	4	W560	3	W9070-1	7		





## 2235 CONTROL SETTINGS

### DC Voltages

AC-GND-DC (both)      GND  
 VOLTS/DIV (both)      0.1V

### AC Waveforms

VERTICAL MODE      BOTH, CHOP  
 A TRIGGER Mode      P-P AUTO

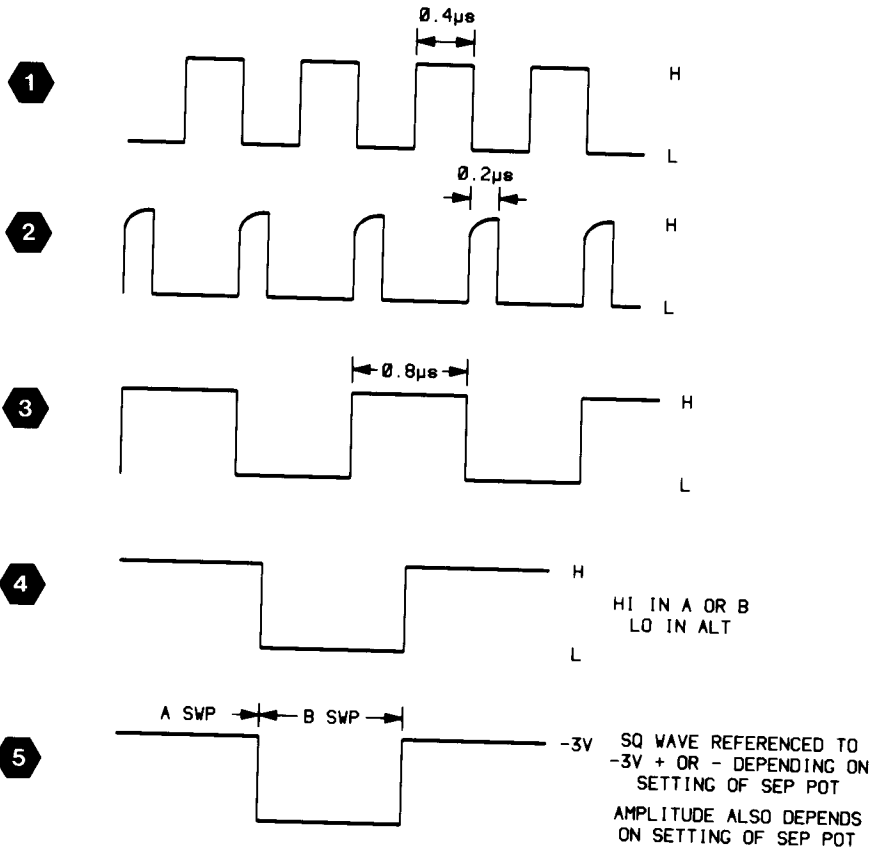

CIRCUIT VIEW  
 OF AT MAIN BOARD      FIG. 6

## VERTICAL PREAMP & OUTPUT AMPLIFIER



ASSEMBLY A1											
CIRCUIT NUMBER	SCHEM LOCATION	BOARD LOCATION	CIRCUIT NUMBER	SCHEM LOCATION	BOARD LOCATION	CIRCUIT NUMBER	SCHEM LOCATION	BOARD LOCATION	CIRCUIT NUMBER	SCHEM LOCATION	BOARD LOCATION
C114	2D	3C	Q206	4J	1C	R186	7F	2D	R289	2N	2E
C115	3D	3C	Q207	6J	1D	R188	5F	2D	R292	1N	2E
C116	2E	3C	Q230	7N	2E	R189	6F	2E	R293	1N	2E
C125	3E	3C	Q231	3N	1E	R192	8H	2D	R440	7H	6C
C126	3F	3C	Q254	7P	1F	R193	9H	2D	R441	7G	6C
C130	3F	2C	Q255	3P	1F	R194	8H	2D	R442	6G	6D
C133	5F	2G	Q256	8P	2F	R195	9H	2D	R443	6G	6D
C164	8D	3D	Q257	2P	1F	R200	5G	2D	R444	6G	6D
C165	9D	3D	Q283	3M	2E	R202	5H	2C	R448	5H	2D
C175	9E	3D	Q284	2N	2E	R203	5H	2C	R449	5H	2C
C176	9F	3D	Q285	2P	2E	R204	5H	2D	R538	5E	5A
C180	9F	2D	Q440	6G	6D	R206	4H	2C	R539	6C	5A
C198	5F	3C	Q441	6G	6D	R207	6J	2D	R540	5E	2H
C210	5J	1D				R210	5J	1C	R541	5E	2H
C215	5J	1C	R100	2A	3C	R212	5J	1C	R544	5C	1J
C225	8J	2C	R101	3A	3C	R213	5J	1D	R545	5C	1J
C226	4K	1C	R102	2B	2D	R215	5J	1C	R547	4D	2J
C228	4L	1D	R103	3B	2C	R216	4J	1C	R548	4D	2J
C229	3L	1D	R104	2B	2C	R217	6J	1D	R549	4E	2J
C237	4N	1E	R105	3B	2C	R218	4J	1C			
C239	5M	2D	R106	2B	2C	R219	6J	1D	RT236	5N	2E
C240	5M	1E	R108	2B	2C	R222	5K	1C			
C241	6M	1D	R109	3B	3C	R223	5K	1D	TP537	4D	1J
C242	5M	2D	R114	2D	3C	R225	7J	1C			
C250	7N	2E	R115	3D	3C	R226	4L	1C	U130	1F	2C
C251	3N	1E	R120	2E	3C	R227	4M	1D	U180	9F	2D
C255	3N	1E	R121	3E	3C	R230	7M	2E	U225	7J	1C
C262	5P	2G	R122	3E	3C	R231	3M	1E	U537A	5D	1J
C281	2M	1F	R125	2E	3C	R233	5N	1E	U537B	4E	1J
C292	1N	2E	R126	2E	3C	R234	6M	2E	U537C	5D	1J
C537	9M	1J	R130	2F	3C	R235	4M	1E	U537D	5C	1J
C538	5D	3G	R131	3F	3C	R236	5N	1E	U540A	5E	2H
C539	6D	3G	R132	5F	1G	R239	5M	2E	U540B	5C	2H
C540	9M	2H	R133	5F	2C	R240	5M	1E			
C545	5C	1J	R135	4F	2C	R241	5M	1D	VR200	5G	2D
C547	4D	2J	R136	4F	2C	R242	5M	2D			
			R138	5F	2C	R244	5L	2D	W282	3L	4E
CR133	5F	2C	R139	5G	2C	R245	6L	2D	W283	3M	3E
CR183	5F	2E	R142	2H	2C	R250	7N	2E	W535	5D	7F
CR200	5G	2C	R143	4H	2C	R251	3N	1E	W537	5D	3H
CR201	6H	2D	R144	2H	2C	R254	7N	1E	W538	5E	2J
CR202	5H	2C	R145	3H	2C	R255	3N	1E	W9001-10	4K	5A
CR203	6H	2D	R150	8B	3E	R256	8P	2F	W9001-14	5B	5A
CR226	4L	1D	R151	9B	3D	R257	2P	1F	W9001-2	2D	4A
CR227	4L	1D	R152	8B	2E	R258	7P	2F	W9001-3	3D	4A
CR228	4L	1D	R153	9B	2D	R259	3P	1F	W9001-4	2L	4A
CR229	4L	1D	R154	8B	2D	R261	5P	1F	W9001-6	7B	5A
			R155	9B	2D	R262	5P	1G	W9001-7	8D	5A
L142	1G	2C	R156	9B	2D	R266	7P	1F	W9001-8	9D	5A
L143	3G	2C	R158	9B	2D	R267	3P	1F	W9001-9	6B	5A
L192	8G	2D	R159	9B	3D	R268	6P	2F	W9103-1	2A	3C
L193	9G	2D	R164	8D	3D	R269	4P	1F	W9103-2	3A	3C
			R165	9D	3D	R270	6P	2F	W9103-3	2A	3C
Q102	2B	2C	R170	9E	3D	R271	5P	1F	W9103-4	3A	3C
Q103	3B	3C	R171	9D	3D	R279	3M	2E	W9108-1	8A	3D
Q114	2E	3C	R172	9E	3D	R281	2L	1E	W9108-2	9A	3D
Q115	3E	3C	R175	9E	3D	R282	2M	1E	W9108-3	8A	3D
Q152	8B	2D	R176	8F	3D	R283	3M	2E	W9108-4	9A	3D
Q153	9B	3D	R180	8F	3D	R284	2N	2E	W9440-1	5G	6D
Q164	8E	3D	R181	9F	3D	R285	2P	2E	W9440-2	5G	6D
Q165	9E	3D	R182	6F	2G	R286	2N	2E	W9440-3	5G	6D
Q202	5H	2C	R183	6F	2E	R287	2P	2E	W9440-4	5G	6D
Q203	6J	2D	R185	7F	2D	R288	2N	1E			

Partial A1 also shown on diagrams 3, 4, 5, 6, 7 and 8.



VERTICAL PREAMP & OUTPUT AMPLIFIER

2 (cont)

ASSEMBLY A3											
CIRCUIT NUMBER	SCHEM LOCATION	BOARD LOCATION	CIRCUIT NUMBER	SCHEM LOCATION	BOARD LOCATION	CIRCUIT NUMBER	SCHEM LOCATION	BOARD LOCATION	CIRCUIT NUMBER	SCHEM LOCATION	BOARD LOCATION
CR534	4A	2B	R162	9D	1C	W534	5B	3B	W9000-7	8D	4B
CR537	4B	2B	R280	2L	1C	W9000-10	4K	4B	W9000-8	9D	4B
CR538	6B	2B				W9000-14	5B	4B	W9000-9	6B	4B
R111	2D	1B	S200	6A	2B	W9000-2	2D	4A			
R112	3D	1B	S226	3K	2C	W9000-3	3D	4A			
R161	9D	1C	S545	4A	2C	W9000-4	2L	4A			
			S550	5A	2B	W9000-6	7B	4B			
<i>Partial A3 also shown on diagrams 1, 3, 4, 5, 6, 7 and 8.</i>											
CHASSIS MOUNTED PARTS											
CIRCUIT NUMBER	SCHEM LOCATION	BOARD LOCATION	CIRCUIT NUMBER	SCHEM LOCATION	BOARD LOCATION	CIRCUIT NUMBER	SCHEM LOCATION	BOARD LOCATION	CIRCUIT NUMBER	SCHEM LOCATION	BOARD LOCATION
C9272	8S	CHASSIS	DL9210	5K	CHASSIS	R9273	2S	CHASSIS	W9273	2S	CHASSIS
C9273	2S	CHASSIS	R9272	8S	CHASSIS	W9272	8S	CHASSIS			

OUTPUT AMPL

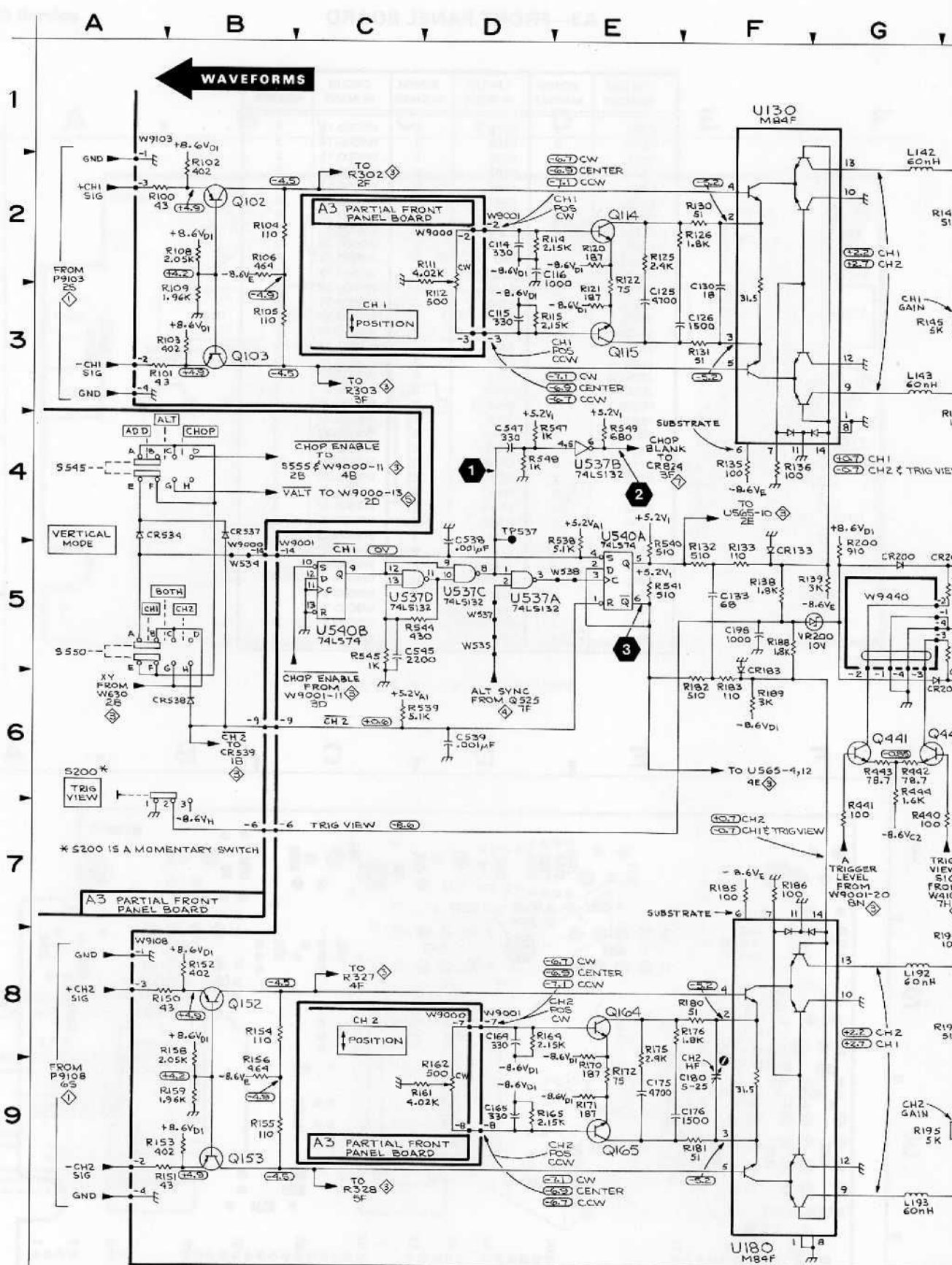

2235

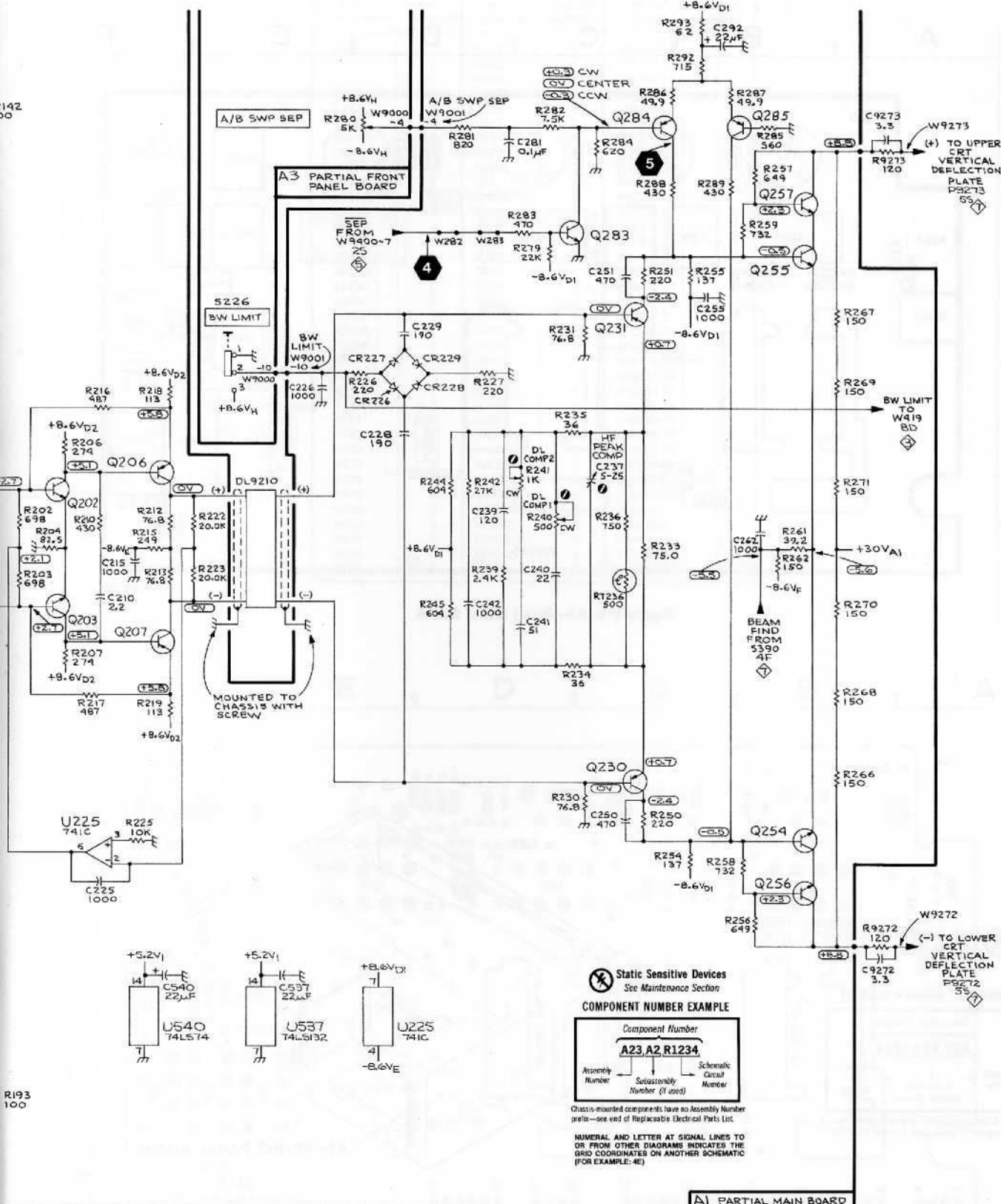

VERTICAL PREAMP & OUTPUT AMPL

2

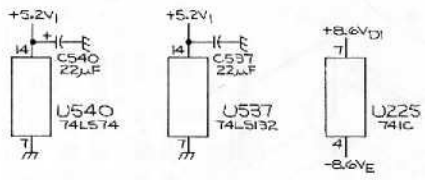

**Static Sensitive Devices**  
See Maintenance Section

**COMPONENT NUMBER EXAMPLE**

Component Number			
A23	A2	R1234	
Assembly Number	Subassembly Number (if used)	Schematic Circuit Number	

Chassis-mounted components have no Assembly Number prefix—see end of Replaceable Electrical Parts List.

NUMERAL AND LETTER AT SIGNAL LINES TO OR FROM OTHER DIAGRAMS INDICATES THE GRID COORDINATES ON ANOTHER SCHEMATIC (FOR EXAMPLE: 4E)

A1 PARTIAL MAIN BOARD

VERTICAL PREAMP & OUTPUT AMPL 2





# TRIGGERING



## ASSEMBLY A1

CIRCUIT NUMBER	SCHEM LOCATION	BOARD LOCATION	CIRCUIT NUMBER	SCHEM LOCATION	BOARD LOCATION	CIRCUIT NUMBER	SCHEM LOCATION	BOARD LOCATION	CIRCUIT NUMBER	SCHEM LOCATION	BOARD LOCATION
C312	2H	4C	R305	3G	3C	R395	6F	5D	TP397	6E	5D
C337	5H	4D	R306	1G	3C	R399	6E	5C	TP460	7J	6C
C363	1M	4C	R307	3G	3C	R402	5N	7C			
C369	7F	5C	R309	2G	4C	R405	5P	7C	U310	1G	4C
C381	5C	8A	R310	2G	4C	R407	5P	7C	U335	4H	4D
C389	5D	8A	R311	2G	4C	R408	5N	7B	U350A	1L	5C
C390	4E	8A	R312	2H	4C	R411	8H	7A	U350B	3M	5C
C392	7D	7A	R314	3J	4C	R412	9H	6B	U350C	3L	5C
C397	6F	4D	R315	1J	3D	R413	9H	7B	U350D	3K	5C
C405	5P	7C	R317	1F	3C	R414	8H	7A	U350E	1K	5C
C408	5P	7C	R318	1G	3C	R415	9J	7B	U426A	8K	6B
C414	8J	6B	R319	2H	4C	R416	8H	6B	U426B	9K	6B
C415	9J	6B	R321	3J	4C	R417	9J	6B	U460A	7L	6C
C418	8E	5C	R322	3J	4C	R419	8F	5C	U460B	7L	6C
C419	7F	5C	R324	3H	4C	R420	7G	6C	U460C	7L	6C
C420	7J	6B	R326	5G	3D	R421	9J	6B	U460D	7K	6C
C421	9K	6B	R327	4G	3D	R422	8J	6B	U460E	7K	6C
C453	7M	6C	R328	5G	3D	R423	9J	6B	U460F	7K	6C
C459	7N	6C	R329	4G	3D	R424	7J	6B	U480A	6P	7C
C473	4P	7B	R330	5G	3D	R426	8J	6B	U480B	5S	7C
C479	6M	6C	R331	4G	3D	R427	9J	6B	U480C	5L	7C
C480	1P	7C	R332	5G	3D	R428	8K	6B	U480D	5M	7C
C553	3P	3E	R335	5H	4D	R429	9K	7B	U555A	2D	4E
C561	4D	3G	R336	5H	4D	R432	9K	6B	U555B	1E	4E
C565	4F	6E	R337	5H	4D	R433	9K	7B	U555C	3E	4E
			R339	5J	4D	R434	9K	7B	U555D	3E	4E
CR372	7G	5C	R340	4J	3D	R435	9K	7B	U565B	3F	2H
CR381	5C	8A	R342	3F	3D	R446	7M	6C	U565C	2F	2H
CR393	7F	6C	R343	3G	4D	R452	8K	6C	U565D	4F	2H
CR399	7F	5C	R344	5J	4D	R453	7L	6C			
CR414	8J	6B	R346	6J	4D	R455	8L	6C	W310	1J	4D
CR415	9J	6B	R347	6J	4D	R457	6K	6C	W335	4J	3D
CR556	2D	4E	R349	6H	4D	R458	7L	6C	W350	1K	4D
			R350	1K	5C	R459	7N	6C	W351	3K	4D
Q302	2G	3C	R351	3K	5C	R460	4K	7C	W410	7G	6C
Q303	3G	3C	R352	2K	5C	R461	7P	6C	W419	8E	5A
Q327	4G	3D	R353	2K	5C	R462	7P	6C	W428	8K	6A
Q328	5G	3D	R356	1L	5C	R463	4L	6C	W429	9K	6A
Q382A	5D	8A	R357	3L	5C	R464	5L	7C	W555	2D	4E
Q382B	5D	8A	R358	2K	5C	R465	5M	7C	W558	2D	4E
Q384	5E	8A	R359	2L	5C	R469	5M	7C	W560	3D	4E
Q397	6F	5D	R360	3L	5D	R470	5L	6C	W9001-11	4C	5A
Q402	5N	7C	R361	3K	5C	R471	5L	7B	W9001-18	2C	6A
Q403	5N	7C	R363	1L	5C	R473	6P	7B	W9001-19	8N	6A
Q413	9J	7B	R365	2M	5C	R474	6N	7C	W9001-20	8M	6A
Q419	8F	5C	R366	3L	5C	R478	5N	7C	W9001-22	8L	6A
Q420	7J	6C	R367	4M	5C	R479	6M	7C	W9001-23	9L	6A
Q421	9J	6C	R369	7F	5C	R483	6M	7C	W9001-31	6C	8A
Q422	7J	6B	R372	7G	5C	R486	5S	7C	W9001-32	2C	8A
Q423	9K	6B	R374	7G	5C	R487	6P	7C	W9001-33	2C	8A
Q428	8K	6B	R381	5C	8A	R555	1C	5B	W9001-34	3C	8A
Q429	9K	6B	R382	5D	8A	R556	1D	3E	W9001-35	7C	8A
Q460	4K	6C	R384	5D	8A	R558	2C	6A	W9001-36	6C	8A
Q463	4L	6C	R385	5E	7A	R560	3C	6B	W9001-37	7C	8A
			R386	6D	7A	R561	4D	5A	W9001-38	6C	8A
R301	2G	3C	R389	6D	8B	R562	2E	2H	W9001-39	4C	8A
R302	2G	3C	R390	4D	8B	R564	4F	2H			
R303	3G	3C	R392	7D	7A	R565	4F	3H			
R304	2G	3C	R393	7E	7B						

Partial A1 also shown on diagrams 2, 4, 5, 6, 7 and 8.

TABLE (cont)



FIG. 9-9, -10  
BOARD

# TRIGGERING



(cont)

<b>ASSEMBLY A3</b>											
CIRCUIT NUMBER	SCHEM LOCATION	BOARD LOCATION	CIRCUIT NUMBER	SCHEM LOCATION	BOARD LOCATION	CIRCUIT NUMBER	SCHEM LOCATION	BOARD LOCATION	CIRCUIT NUMBER	SCHEM LOCATION	BOARD LOCATION
C376	5B	3F	R377	5B	3F	W539	1B	3B	W9000-33	2C	4E
C377	5B	3F	R378	6B	2E	W630	2B	3B	W9000-34	3C	4E
C379	6B	2F	R379	6B	2E	W9000-11	4C	4B	W9000-35	7C	4E
C380	5B	3F	R380	5B	4F	W9000-18	2C	4C	W9000-36	6C	4E
CR539	1B	2B	R438	8M	2F	W9000-19	8N	4C	W9000-37	7C	4E
CR648	1B	3D	S380	4B	3F	W9000-20	8M	4C	W9000-38	6C	4E
J9250-2	2B	3D	S392	6B	3E	W9000-22	8M	4C	W9000-39	4C	4F
J9250-3	3B	3E	S460	8N	2E	W9000-23	9M	4C			
			S555	2B	3E	W9000-31	6C	4E			
						W9000-32	2C	4E			
<i>Partial A3 also shown on diagrams 1, 2, 4, 5, 6, 7 and 8.</i>											
<b>ASSEMBLY A4</b>											
CIRCUIT NUMBER	SCHEM LOCATION	BOARD LOCATION	CIRCUIT NUMBER	SCHEM LOCATION	BOARD LOCATION	CIRCUIT NUMBER	SCHEM LOCATION	BOARD LOCATION	CIRCUIT NUMBER	SCHEM LOCATION	BOARD LOCATION
P9250-2	2A	2E	P9250-3	3A	2E						
<i>Partial A4 also shown on diagrams 4, 5 and 6.</i>											
<b>CHASSIS MOUNTED PARTS</b>											
CIRCUIT NUMBER	SCHEM LOCATION	BOARD LOCATION	CIRCUIT NUMBER	SCHEM LOCATION	BOARD LOCATION	CIRCUIT NUMBER	SCHEM LOCATION	BOARD LOCATION	CIRCUIT NUMBER	SCHEM LOCATION	BOARD LOCATION
J9376	5A	CHASSIS	R9376	5A	CHASSIS						



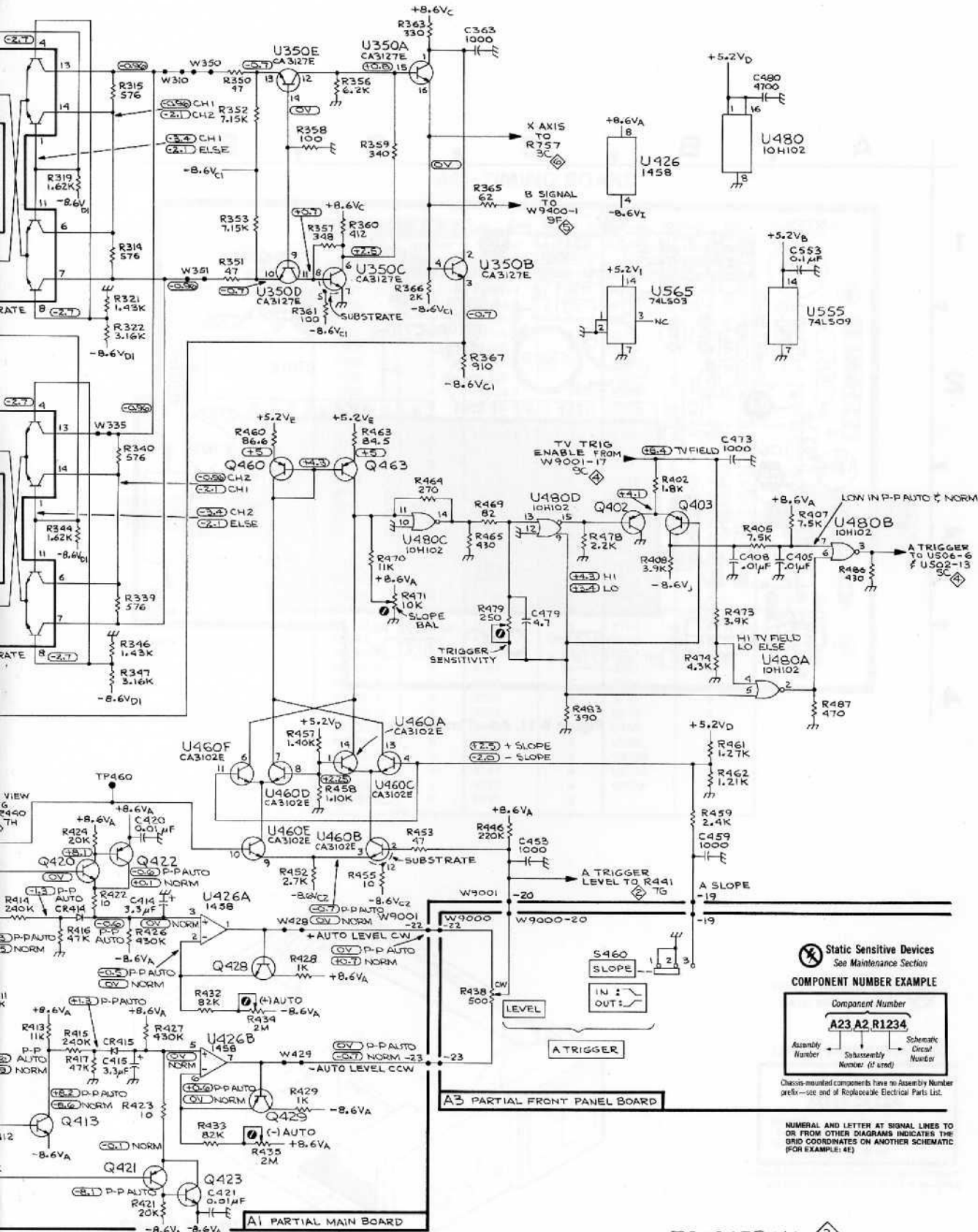

Static Sensitive Devices  
See Maintenance Section

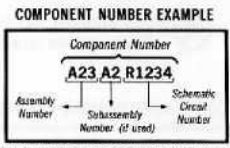

NUMERAL AND LETTER AT SIGNAL LINES TO OR FROM OTHER DIAGRAMS INDICATES THE GRID COORDINATES ON ANOTHER SCHEMATIC (FOR EXAMPLE: 4E)

TRIGGERING

TRIGGERING 3

3

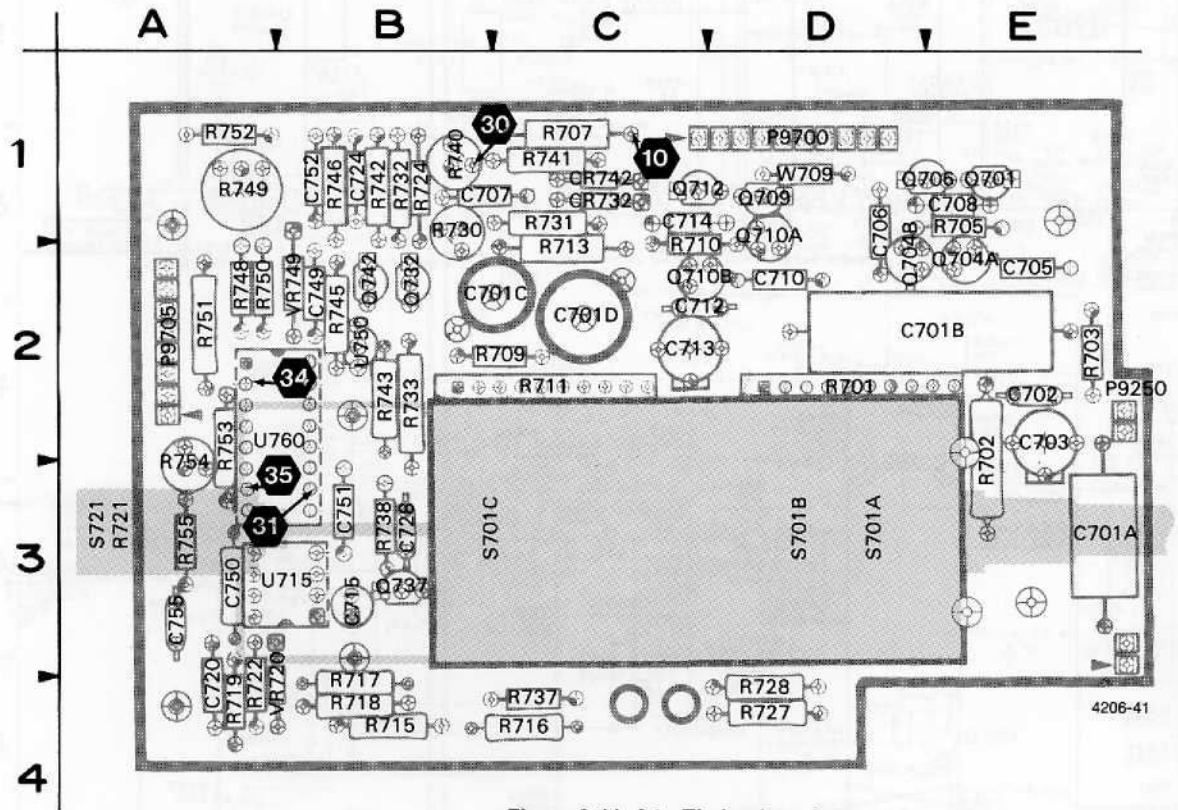
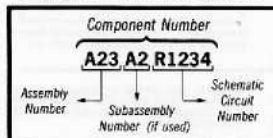

Figure 9-11. A4—Timing board.

 Static Sensitive Devices  
See Maintenance Section

COMPONENT NUMBER EXAMPLE



Chassis-mounted components have no Assembly Number prefix—see end of Replaceable Electrical Parts List.

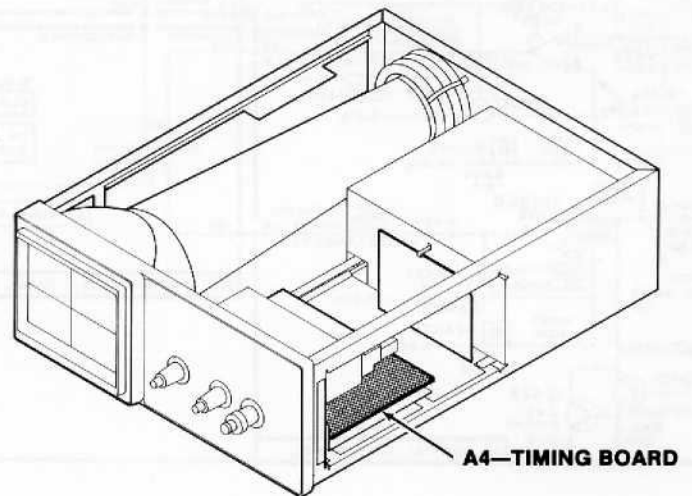

### A4—TIMING BOARD

CIRCUIT NUMBER	SCHEM NUMBER	CIRCUIT NUMBER	SCHEM NUMBER	CIRCUIT NUMBER	SCHEM NUMBER
C701	4	P9700-7	4	R721	4
C701	4	P9700-8	5	R722	4
C701	5	P9700-9	5	R724	6
C701	5	P9705-1	6	R727	6
C702	4	P9705-2	6	R728	6
C703	4	P9705-3	6	R730	6
C705	4	P9705-4	6	R731	6
C706	4	P9705-5	6	R732	6
C707	6	P9705-6	6	R733	6
C708	4	P9705-7	6	R737	6
C710	5	P9705-8	6	R738	6
C712	5	Q701	4	R740	6
C713	5	Q704	4	R741	6
C714	5	Q704	4	R742	6
C715	4	Q706	4	R743	6
C720	4	Q709	5	R745	6
C724	6	Q710	5	R746	6
C728	6	Q710	5	R748	6
C749	6	Q712	5	R749	6
C750	6	Q732	6	R750	6
C751	6	Q737	6	R751	6
C752	6	Q742	6	R752	6
C755	6	R701	4	R753	6
CR732	6	R702	4	R754	6
CR742	6	R703	4	R755	6
P9250-1	6	R705	4	S701	4
P9250-2	3	R707	4	S701	4
P9250-3	3	R709	5	S701	5
P9250-4	4	R710	5	S721	6
P9700-10	4	R711	5	U715	4
P9700-1	6	R713	5	U750	6
P9700-2	6	R715	4	U760	6
P9700-3	5	R716	4	VR720	4
P9700-4	4	R717	4	VR749	6
P9700-5	4	R718	4	W709	5
P9700-6	4	R719	4		

## 2235 CONTROL SETTINGS

### DC Voltages

A INTENSITY	Midrange
HORIZONTAL MODE	A
A SEC/DIV	0.1 ms
A TRIGGER Mode	P-P AUTO

### AC Waveforms

VERTICAL MODE	CH 1
CH 1 VOLTS/DIV	1V
CH 1 AC-GND-DC	DC
HORIZONTAL MODE	A
A TRIGGER LEVEL	Midrange
A TRIGGER Mode	P-P AUTO
A SOURCE	INT
A&B INT	CH 1
CH 1 INPUT SIGNAL	1-kHz sine wave, 4V P-P

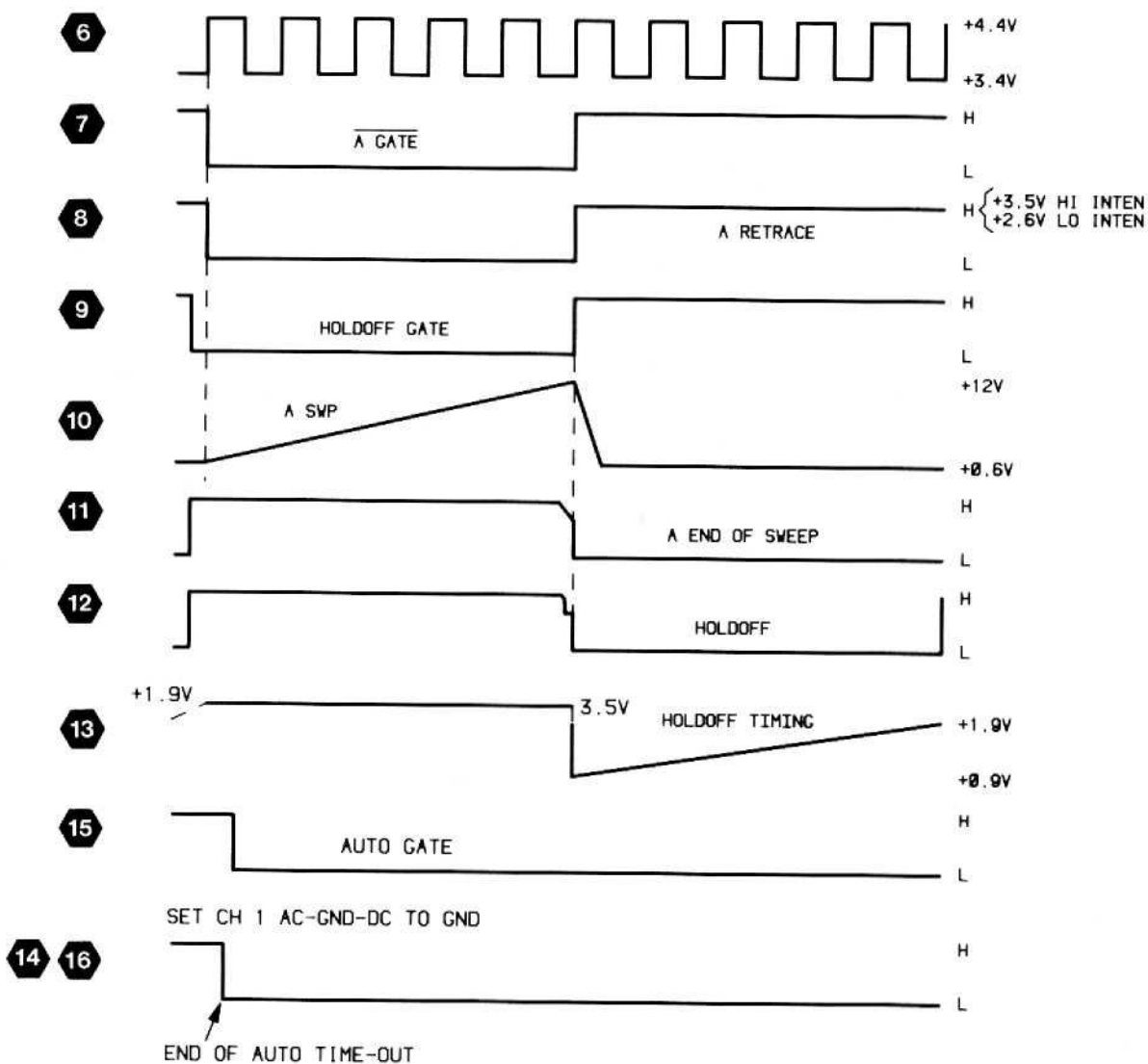



A B C D E F G

1  
2  
3  
4  
5  
6  
7  
8  
9

**WAVEFORMS**

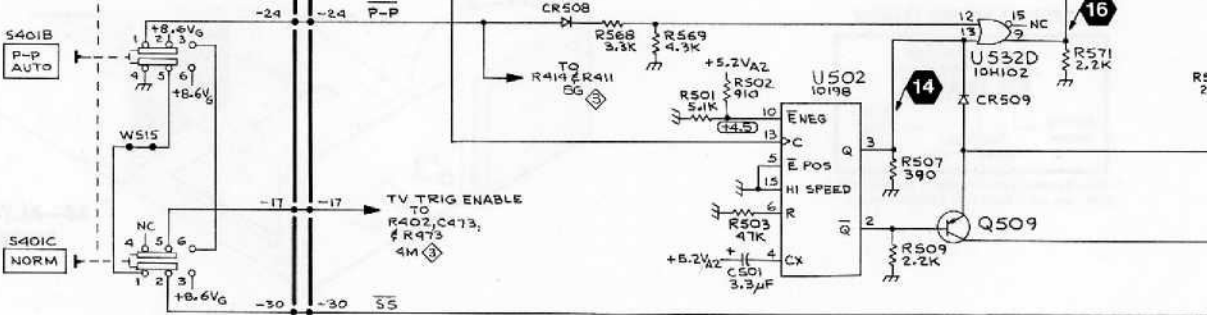
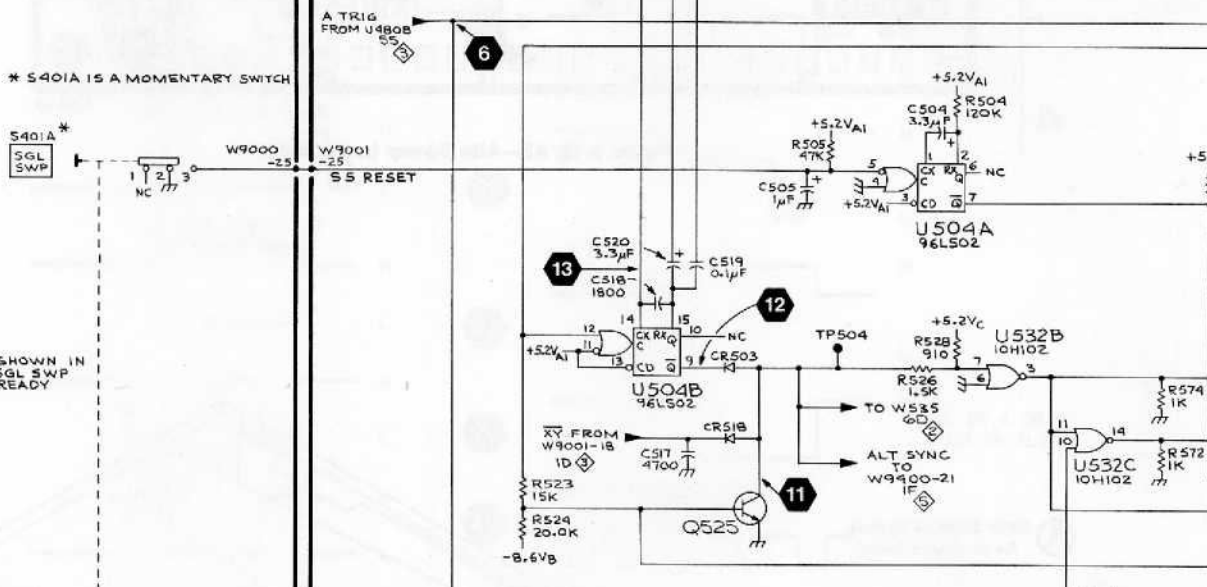
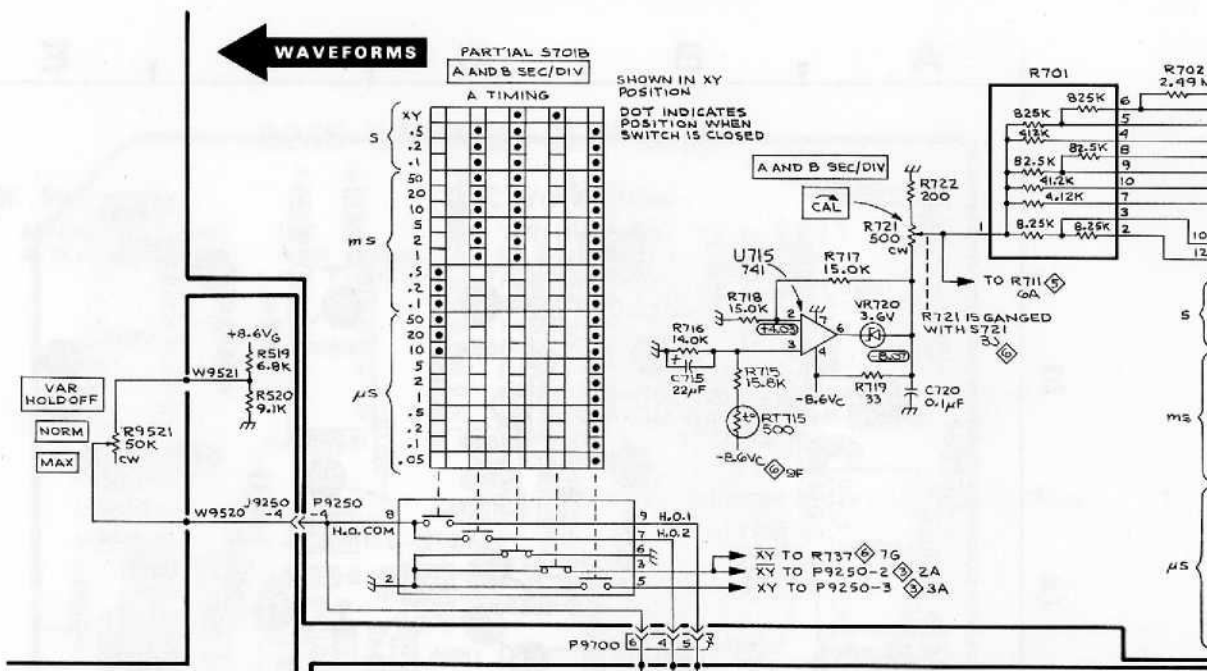
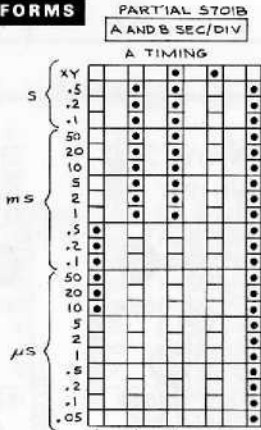

A3 PARTIAL FRONT PANEL BOARD | A1 PARTIAL MAIN BOARD

H J K L M N P S

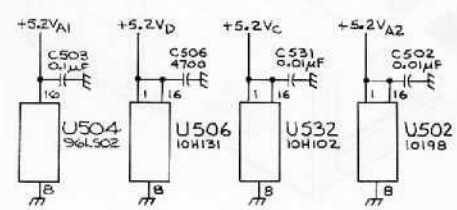
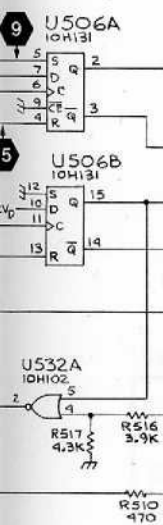
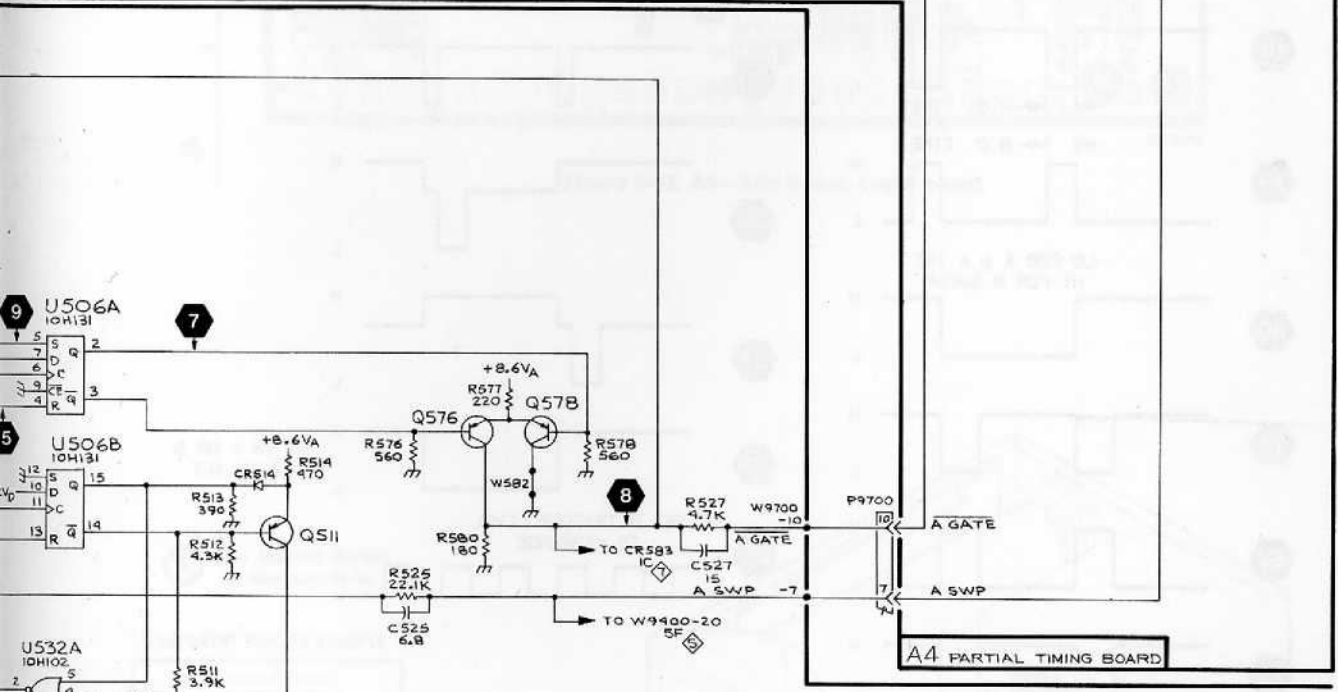
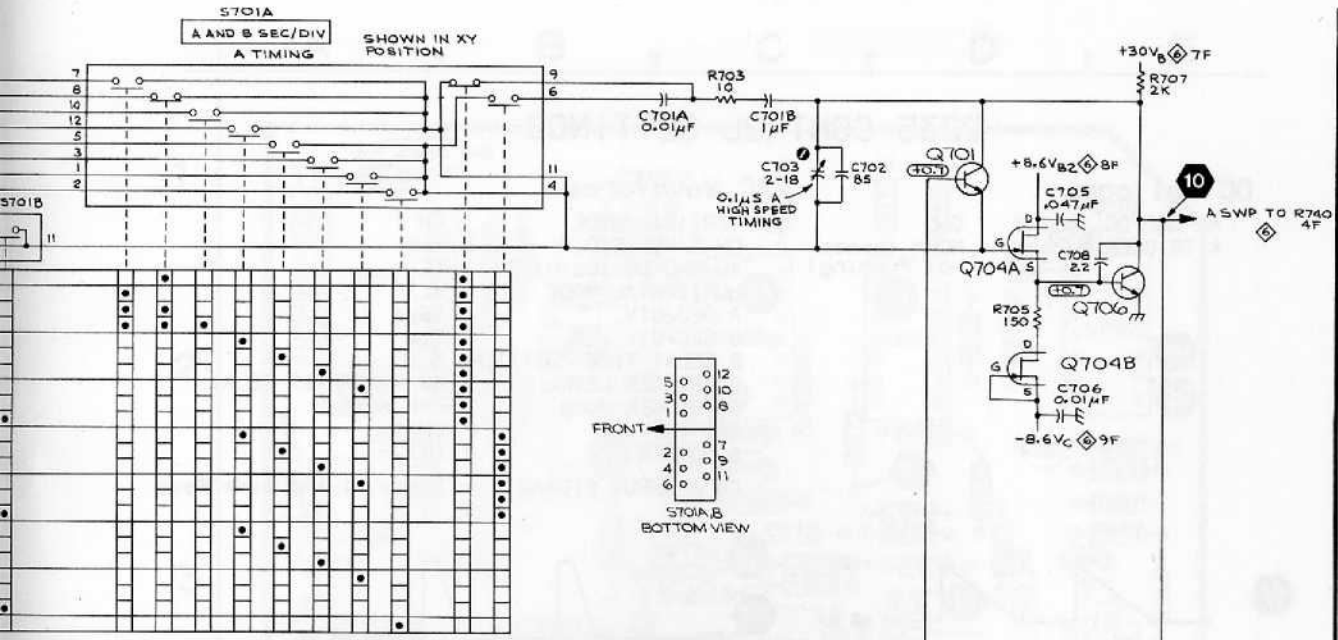

Static Sensitive Devices  
See Maintenance Section

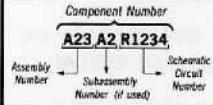

Chassis mounted components have no Assembly Number prefix—see end of Replaceable Electrical Parts List.

NUMERAL AND LETTER AT SIGNAL LINES TO OR FROM OTHER DIAGRAMS INDICATES THE GRID COORDINATES ON ANOTHER SCHEMATIC (FOR EXAMPLE: 4E)

## 2235 CONTROL SETTINGS

### DC Voltages

AC-GND-DC (both) GND  
 A TRIGGER Mode NORM (sweep not running)

### AC Waveforms

VERTICAL MODE CH 1  
 CH 1 VOLTS/DIV 5mV  
 AC-GND-DC (both) DC  
 HORIZONTAL MODE ALT  
 A SEC/DIV 50µs  
 B SEC/DIV 5µs  
 B DELAY TIME POSITION 5.0  
 B TRIGGER LEVEL CW-RUN AFTER DELAY  
 A TRIGGER Mode P-P AUTO  
 A&B INT CH 1  
 A SOURCE INT  
 CH 1 INPUT SIGNAL 5-div, 1-kHz sine wave

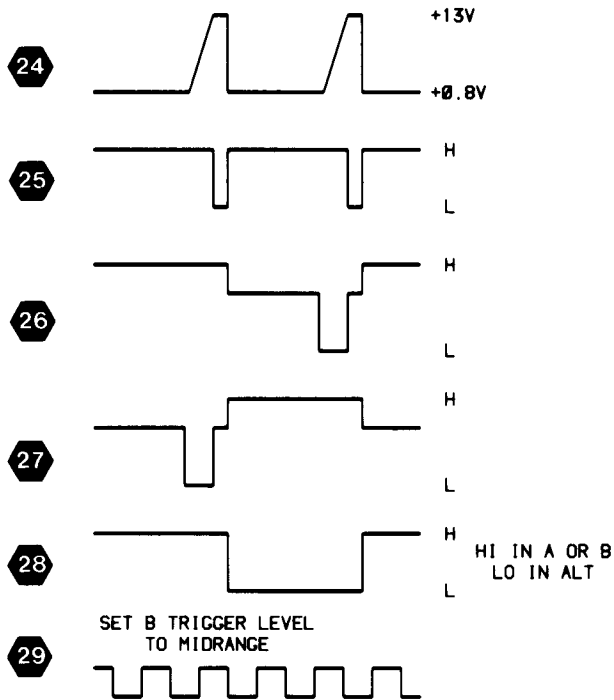
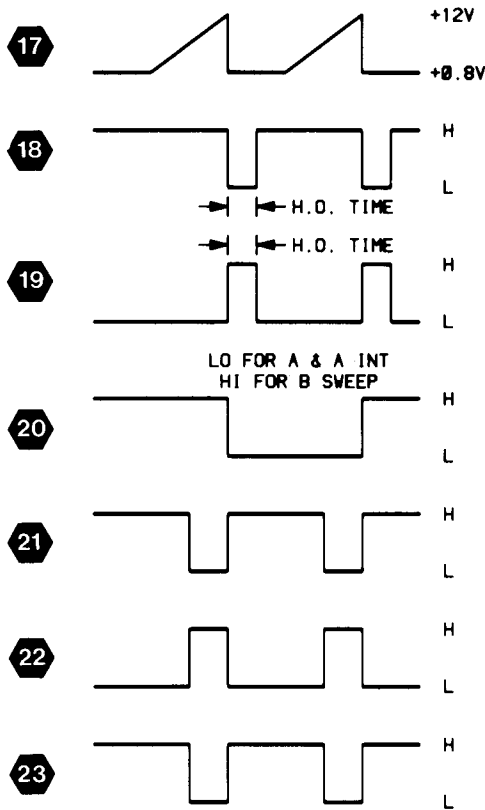

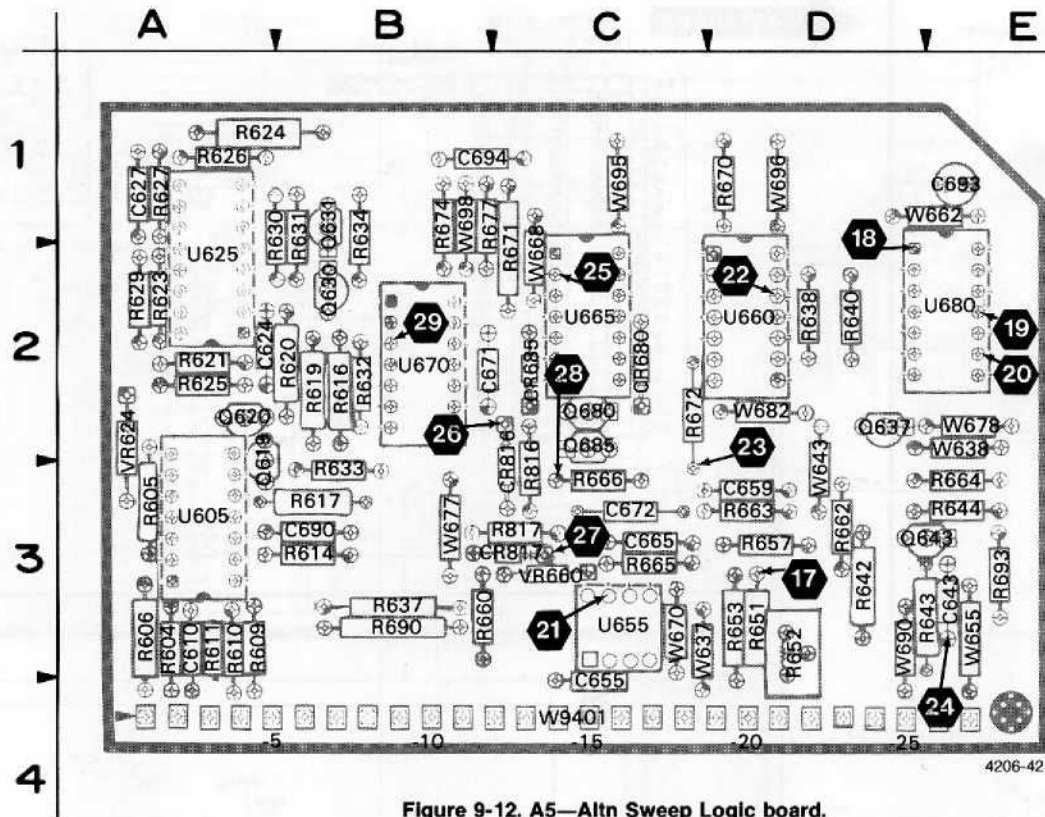
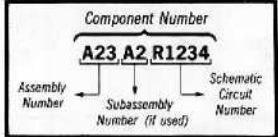

Figure 9-12. A5—Altn Sweep Logic board.

 Static Sensitive Devices  
See Maintenance Section

**COMPONENT NUMBER EXAMPLE**



Chassis-mounted components have no Assembly Number prefix—see end of Replaceable Electrical Parts List.

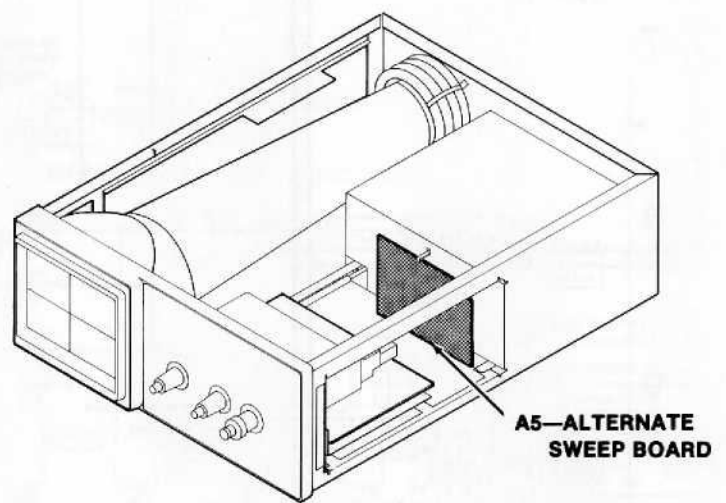

### A5—ALTERNATE SWEEP BOARD

CIRCUIT NUMBER	SCHEM NUMBER	CIRCUIT NUMBER	SCHEM NUMBER	CIRCUIT NUMBER	SCHEM NUMBER	CIRCUIT NUMBER	SCHEM NUMBER
C610	5	R623	5	U605	5	W677	5
C624	5	R624	5	U605	5	W678	5
C627	5	R625	5	U605	5	W682	5
C643	5	R626	5	U605	5	W690	5
C655	5	R627	5	U605	5	W695	5
C659	5	R629	5	U605	5	W696	5
C665	5	R630	5	U625	5	W698	5
C671	5	R631	5	U625	5	W9401-10	5
C672	5	R632	5	U625	5	W9401-11	5
C690	5	R633	5	U625	5	W9401-12	5
C693	5	R634	5	U655	5	W9401-13	5
C694	5	R637	5	U660	5	W9401-14	5
CR680	5	R638	5	U660	5	W9401-15	5
CR685	5	R640	5	U660	5	W9401-16	5
CR816	5	R642	5	U660	5	W9401-17	5
CR817	5	R643	5	U660	5	W9401-18	5
Q619	5	R644	5	U660	5	W9401-19	5
Q620	5	R651	5	U665	5	W9401-1	5
Q630	5	R652	5	U665	5	W9401-20	5
Q631	5	R653	5	U665	5	W9401-21	5
Q637	5	R657	5	U665	5	W9401-22	5
Q643	5	R660	5	U670	5	W9401-23	5
Q680	5	R662	5	U670	5	W9401-24	5
Q685	5	R663	5	U680	5	W9401-25	5
R604	5	R664	5	U680	5	W9401-26	5
R605	5	R665	5	U680	5	W9401-27	5
R606	5	R666	5	U680	5	W9401-2	5
R609	5	R670	5	VR624	5	W9401-3	5
R610	5	R671	5	VR660	5	W9401-4	5
R611	5	R672	5	W637	5	W9401-5	5
R614	5	R674	5	W638	5	W9401-6	5
R616	5	R677	5	W643	5	W9401-7	5
R617	5	R690	5	W655	5	W9401-8	5
R619	5	R693	5	W662	5	W9401-9	5
R620	5	R816	5	W668	5		
R621	5	R817	5	W670	5		

### B TIMING & ALTERNATE B SWEEP



ASSEMBLY A1											
CIRCUIT NUMBER	SCHEM LOCATION	BOARD LOCATION	CIRCUIT NUMBER	SCHEM LOCATION	BOARD LOCATION	CIRCUIT NUMBER	SCHEM LOCATION	BOARD LOCATION	CIRCUIT NUMBER	SCHEM LOCATION	BOARD LOCATION
C603	9F	5E	R645	4E	8E	W9001-13	2E	5A	W9400-20	5F	7E
C635	2F	7F	R646	5E	8D	W9001-15	1E	6A	W9400-21	1F	7E
C646	5F	7E	R647	5F	8E	W9001-16	9F	6A	W9400-22	6F	7E
C647	3E	6E	R648	1F	8D	W9001-26	2E	7A	W9400-2	9F	5E
C648	1F	6E	R649	2E	8D	W9001-27	2E	7A	W9400-4	9F	6E
C649	3F	6E	R673	6F	7E	W9001-28	9F	7A	W9400-5	1S	6E
C673	7F	7E				W9400-10	2F	6E	W9400-6	2F	6E
			VR645	5E	8D	W9400-11	2S	6E	W9400-7	2S	6E
CR712	6F	7E	VR712	6F	7E	W9400-12	2F	6E	W9700-3	6F	7E
						W9400-13	1F	6E	W9700-9	6F	7E
P9644-1	4E	8E	W602	9F	6E	W9400-14	5F	7E			
P9644-2	5E	8E	W603	9F	6E	W9400-17	6F	7E			
P9644-3	5E	8E	W635	2E	7F	W9400-19	2F	7E			
			W649	2F	6E	W9400-1	9F	5E			

Partial A1 also shown on diagrams 2, 3, 4, 6, 7 and 8.









## 2235 CONTROL SETTINGS

### DC Voltages

AC-GND-DC (both)	GND
HORIZONTAL MODE	A
A TRIGGER Mode	P-P AUTO

### AC Waveforms

AC-GND-DC (both)	GND
HORIZONTAL MODE	A
X10 Magnifier	Off (knob in)
VAR HOLDOFF	MIN (fully ccw)
A TRIGGER Mode	P-P AUTO

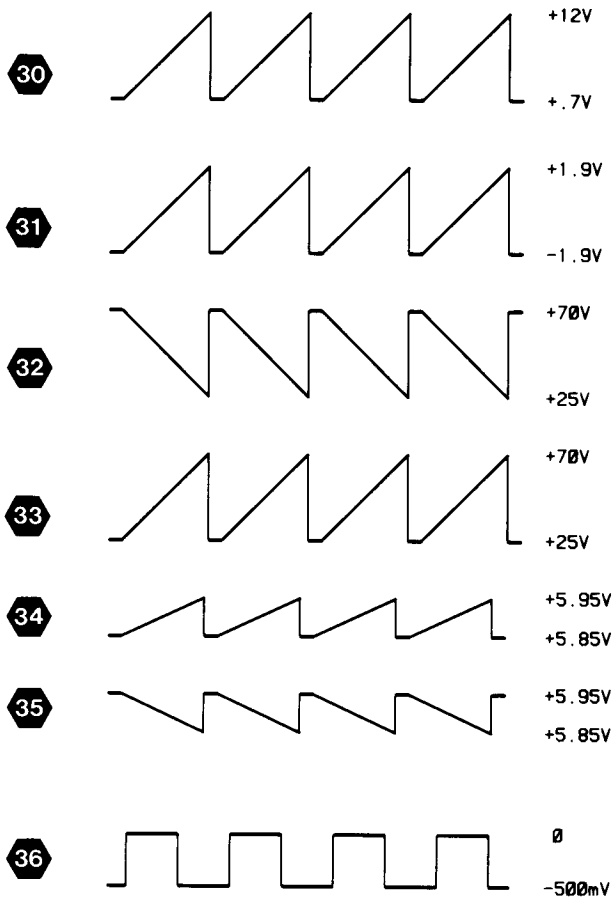



A B C D E F G

1  
2  
3  
4  
5  
6  
7  
8  
9

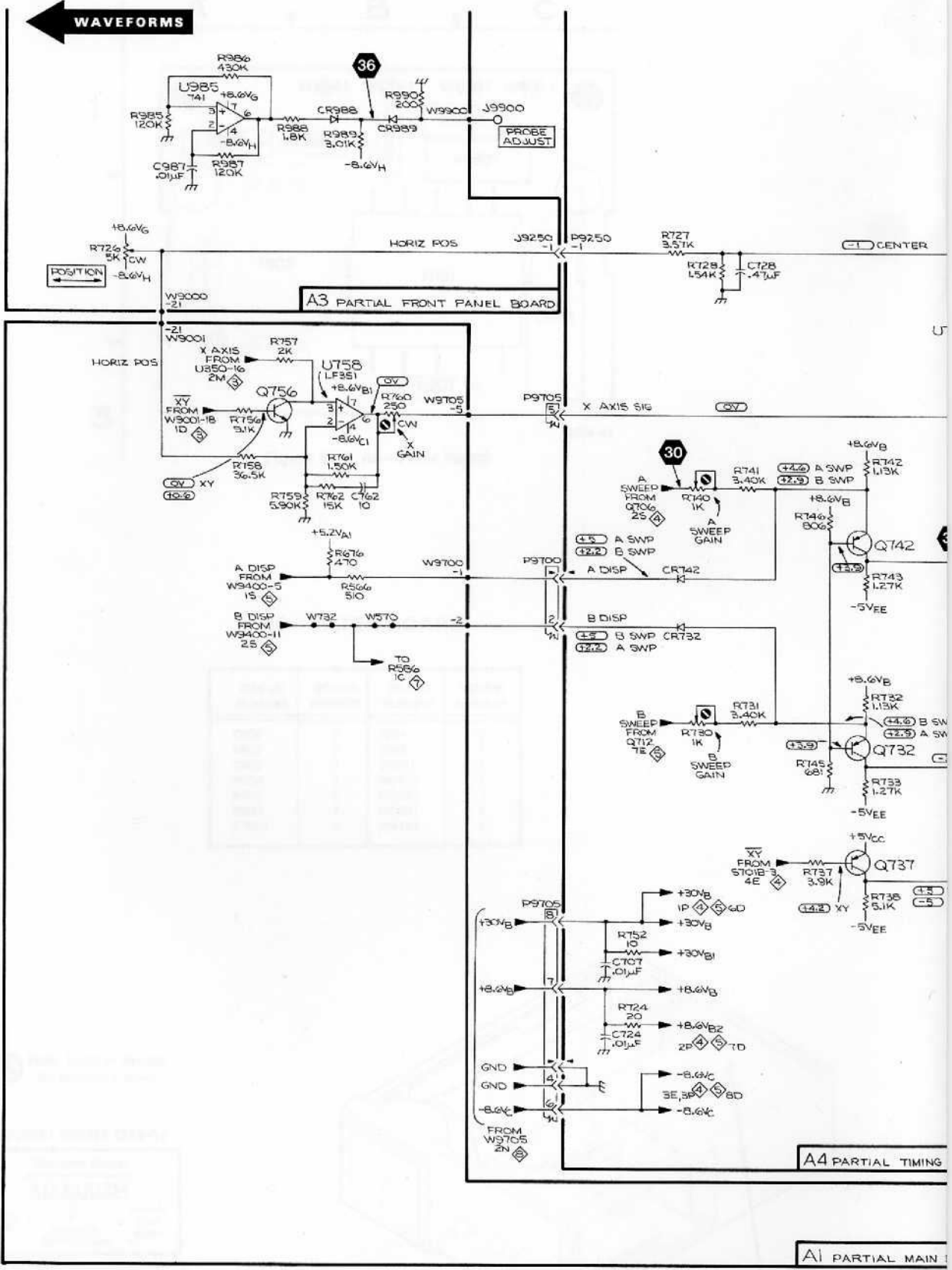



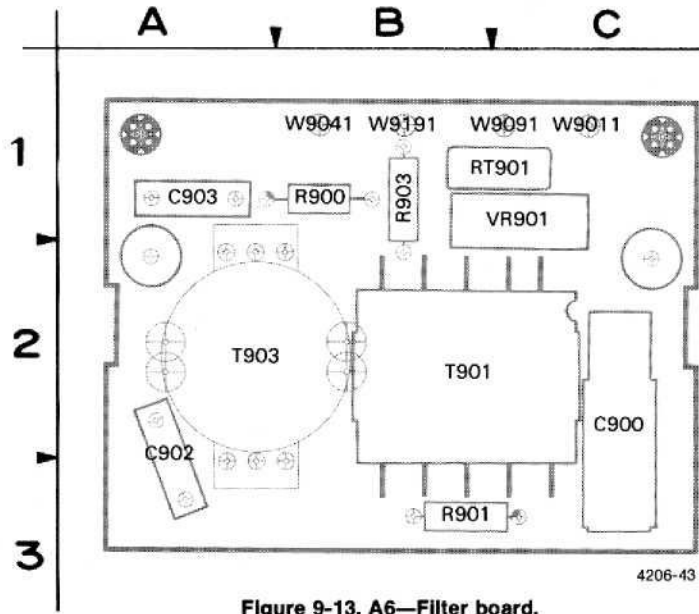

Figure 9-13. A6—Filter board.

**A6—FILTER BOARD**

CIRCUIT NUMBER	SCHEM NUMBER	CIRCUIT NUMBER	SCHEM NUMBER
C900	7	T901	7
C902	7	T903	7
C903	7	VR901	7
R900	7	W9011	7
R901	7	W9041	7
R903	7	W9091	7
RT901	7	W9191	7

 **Static Sensitive Devices**  
See Maintenance Section

**COMPONENT NUMBER EXAMPLE**

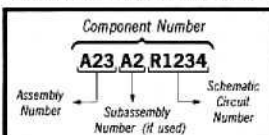

Chassis-mounted components have no Assembly Number prefix—see end of Replaceable Electrical Parts List.

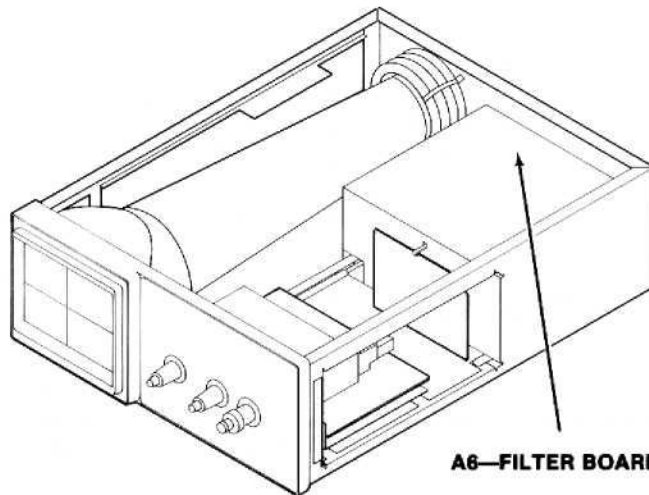

**A6—FILTER BOARD**

POWER SUPPLY, Z AXIS & CRT



ASSEMBLY A1											
CIRCUIT NUMBER	SCHEM LOCATION	BOARD LOCATION	CIRCUIT NUMBER	SCHEM LOCATION	BOARD LOCATION	CIRCUIT NUMBER	SCHEM LOCATION	BOARD LOCATION	CIRCUIT NUMBER	SCHEM LOCATION	BOARD LOCATION
C396	6D	4H	CR901	5E	5J	R810	3B	4B	R929	6F	7J
C824	3E	6E	CR902	5E	5J	R814	3B	4B	R930	6F	7J
C825	3F	3H	CR903	5E	5J	R818	1D	6E	R934	9C	8J
C828	4F	3H	CR904	5E	5J	R820	2D	6E	R935	9C	8J
C832	2G	3H	CR907	7J	6H	R822	4E	2J	R937	9C	8H
C835	4H	3J	CR908	8H	7H	R823	3E	2J	R938	9C	8J
C845	3H	3J	CR920	6J	7J	R825	3E	3J	R939	9C	8H
C847	3J	3J	CR945	9F	8H	R826	3E	2J	R940	9C	8H
C849	3J	3J	CR946	9J	8H	R828	4F	2G	R941	9E	8J
C851	7M	6H	CR947	9J	8H	R830	3G	2J	R942	9D	8J
C853	7M	6G	CR954	6K	6F	R832	3G	3J	R943	9E	8J
C854	6M	5G	CR955	7K	6F	R834	4H	3J	R944	9F	8J
C855	3M	5G	CR956	7K	6F	R835	4G	3J	R945	9F	8H
C871	4S	1H	CR957	7K	6F	R836	4G	3J	R946	9H	8H
C873	5S	1H	CR960	8K	7F	R840	4H	3J	R947	9H	7H
C875	6S	1H	CR961	9K	8F	R841	3G	3J	R949	9H	8H
C877	7S	1H	CR962	9K	7F	R842	3J	3J	R971	9L	8G
C879	8N	5H	CR963	9K	8F	R844	3H	3J	R976	4L	5G
C893	7N	4G	CR967	9K	8G	R845	3H	3J	R978	4L	5G
C904	5D	4J	CR970	9K	8G	R849	3J	3J			
C906	5F	5H				R851	7M	3J	S901	5D	4J
C907	7J	6J	DS856	5M	5G	R852	7M	3J			
C908	6H	5J	DS858	5M	5G	R853	7M	6G	T390	6D	4H
C917	8D	7H	DS870	8L	5G	R854	6M	5G	T906	6J	6J
C919	8F	8J				R858	6M	5G	T944	9H	7H
C922	7F	7J	E907	8H	6H	R860	4M	5G	T948	4J	6G
C925	6E	8J				R870	4S	1H			
C940	9G	6H	L960	8L	7F	R871	4S	1H	TP842	3J	3J
C941	9G	6H	L961	9L	8F	R872	5S	1H	TP900	9L	8E
C942	9D	8H				R873	4S	1G	TP940	9D	8J
C943	9C	8H	P9802-1	3B	4B	R874	6S	1G	TP950	9C	7H
C944	9F	7H	P9802-2	3B	4B	R875	6S	1G			
C945	9F	8J	P9802-3	2B	4B	R877	7S	1H	U930	9G	7J
C954	6K	6F	P9802-4	3B	4B	R879	8N	6F	U975	4K	5F
C956	7K	6F	P9802-5	2B	4B	R885	1K	4H			
C960	9L	6F				R886	2L	4G	VR828	4F	3H
C961	9L	8F	Q586	1D	6D	R888	1L	4G	VR925	7F	7J
C962	9L	7F	Q804	2B	5B	R889	1M	4G	VR935	9C	8J
C963	9L	8F	Q814	3C	5B	R890	1M	4G	VR943	9E	8J
C968	9L	8G	Q825	3F	3J	R891	1M	4G			
C970	9L	8G	Q829	3G	3J	R892	6N	4F	W9040	5D	5J
C975	5L	5G	Q835	4H	3J	R893	6N	4F	W9190	5D	5H
C976	5L	5G	Q840	4J	3J	R894	6M	5F	W9800	4B	3J
C979	5M	5G	Q845	3J	3J	R905	6D	4J	W9001-1	4F	4A
			Q885	1L	4G	R906	6D	5J	W9070-1	8H	6H
CR551	2C	6D	Q908	8H	7H	R907	9J	6H	W9070-2	7H	6H
CR583	1C	6D	Q928	6F	7J	R908	8H	7J	W9070-3	8H	7H
CR805	2C	5B	Q930	6G	7J	R910	7B	5A	W9150-1	7B	5A
CR818	1D	6E	Q935	9B	8J	R912	9C	7J	W9150-2	8B	5A
CR820	2D	6E	Q938	9D	8J	R913	8C	7J	W9400-8	3C	6E
CR823	3E	2H	Q939	9E	8J	R914	8D	7H	W9400-9	3E	6E
CR824	2F	2J	Q944	9F	8J	R915	8D	7J	W9870-10	4S	1H
CR825	3G	3J	Q946	9H	8H	R916	8F	7J	W9870-12	3N	4G
CR829	3F	3J	Q947	9H	7H	R917	8D	7H	W9870-14	8N	4G
CR840	4H	3J				R919	8F	8J	W9870-1	8N	4G
CR845	3H	3J	R397	6D	5E	R921	8E	7J	W9870-2	8N	4G
CR851	7M	6G	R398	6D	5E	R922	8F	7J	W9870-3	7N	4G
CR853	6M	5G	R586	1C	6E	R925	6F	7J	W9870-4	7N	4G
CR854	5M	5G	R800	2B	4B	R926	5E	7J	W9870-5	6S	1H
CR855	5M	5G	R804	2B	4B	R927	7F	7J	W9870-7	5S	1H
CR879	8M	6G	R805	2B	5B	R928	6F	7J	W9870-8	7S	1H

Partial A1 also shown on diagrams 2, 3, 4, 5, 6 and 8.



POWER SUPPLY, Z AXIS & CRT



(cont)

ASSEMBLY A3											
CIRCUIT NUMBER	SCHEM LOCATION	BOARD LOCATION	CIRCUIT NUMBER	SCHEM LOCATION	BOARD LOCATION	CIRCUIT NUMBER	SCHEM LOCATION	BOARD LOCATION	CIRCUIT NUMBER	SCHEM LOCATION	BOARD LOCATION
P9006-1	3S	2A	R982	3S	2A	S390	4E	2A			
P9006-2	3S	2A	R983	3S	2A	W9000-1	4F	4A			
<i>Partial A3 also shown on diagrams 1, 2, 3, 4, 5, 6 and 8.</i>											
ASSEMBLY A6											
CIRCUIT NUMBER	SCHEM LOCATION	BOARD LOCATION	CIRCUIT NUMBER	SCHEM LOCATION	BOARD LOCATION	CIRCUIT NUMBER	SCHEM LOCATION	BOARD LOCATION	CIRCUIT NUMBER	SCHEM LOCATION	BOARD LOCATION
C900	5B	2C	R901	5B	3B	T901	5B	2B	W9011	5A	1C
C902	5C	2A	R903	5C	1B	T903	5C	2A	W9041	5C	1B
C903	5C	1A							W9091	5A	1C
R900	5C	1B	RT901	5B	1B	VR901	5B	1C	W9191	5C	1B
CHASSIS MOUNTED PARTS											
CIRCUIT NUMBER	SCHEM LOCATION	BOARD LOCATION	CIRCUIT NUMBER	SCHEM LOCATION	BOARD LOCATION	CIRCUIT NUMBER	SCHEM LOCATION	BOARD LOCATION	CIRCUIT NUMBER	SCHEM LOCATION	BOARD LOCATION
DS9150	8A	CHASSIS	P9273	5P	CHASSIS	P9870-1	8P	CHASSIS	R9802A	2A	CHASSIS
F9001	5A	CHASSIS	P9778	4P	CHASSIS	P9870-2	8N	CHASSIS	R9802B	3A	CHASSIS
FL9001	5A	CHASSIS	P9788	4P	CHASSIS	P9870-3	7N	CHASSIS			
J9800	4A	CHASSIS	P9070-1	8J	CHASSIS	P9870-4	7N	CHASSIS	V9870	2P	CHASSIS
P9272	5P	CHASSIS	P9070-2	8J	CHASSIS	P9870-5	6P	CHASSIS			
			P9070-3	8J	CHASSIS	P9870-7	5P	CHASSIS			
			P9870-10	4P	CHASSIS	P9870-8	7P	CHASSIS			
			P9870-12	3N	CHASSIS						
			P9870-14	8P	CHASSIS	Q9070	8J	CHASSIS			

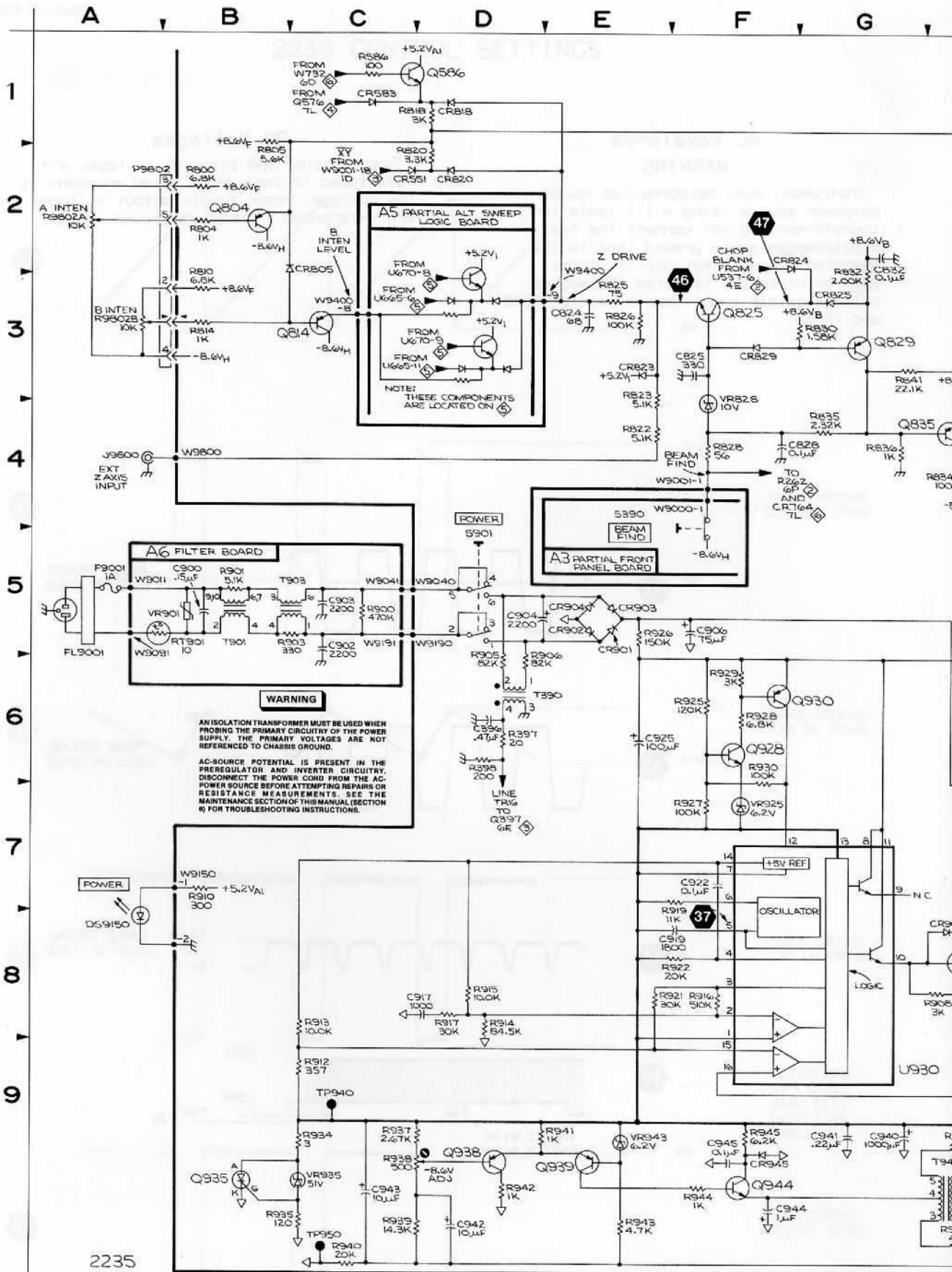

WAVEFORMS →

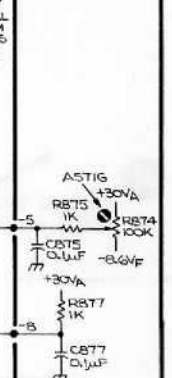
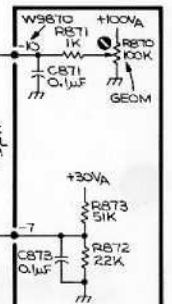
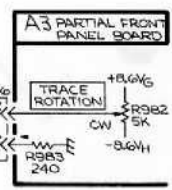
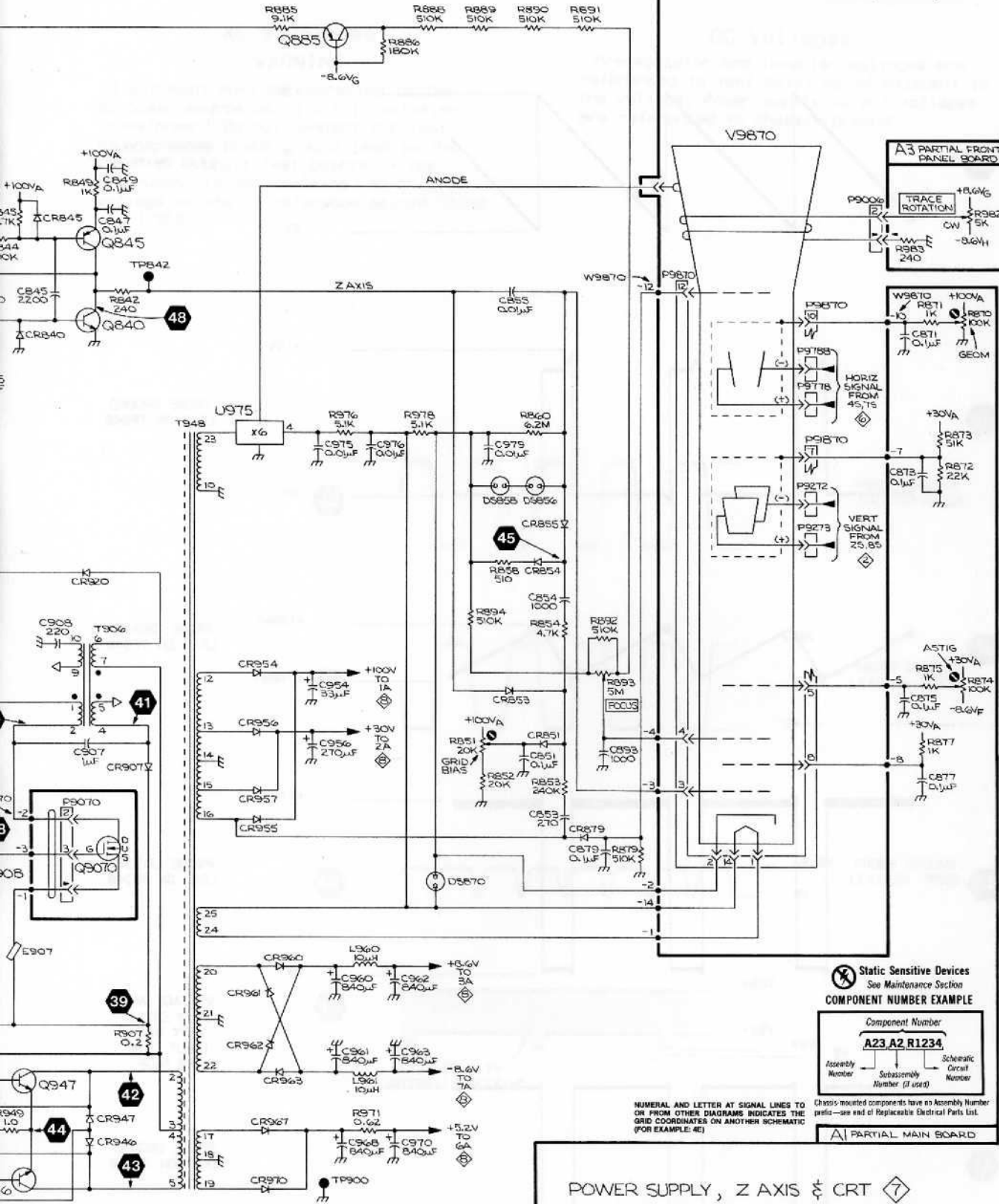

⊗ Static Sensitive Devices  
See Maintenance Section

COMPONENT NUMBER EXAMPLE

Component Number		
<b>A23 A2 R1234</b>		
Assembly Member	Subassembly Number (if used)	Schematic Circuit Number

Chassis-mounted components have no Assembly Number prefix—see end of Replaceable Electrical Parts List.

**A** PARTIAL MAIN BOARD

NUMERAL AND LETTER AT SIGNAL LINES TO OR FROM OTHER DIAGRAMS INDICATES THE GRID COORDINATES ON ANOTHER SCHEMATIC (FOR EXAMPLE: 4E)

POWER SUPPLY, Z AXIS & CRT 7  
4206-29

POWER SUPPLY,  
Z AXIS & CRT

7

# 2235 CONTROL SETTINGS

37

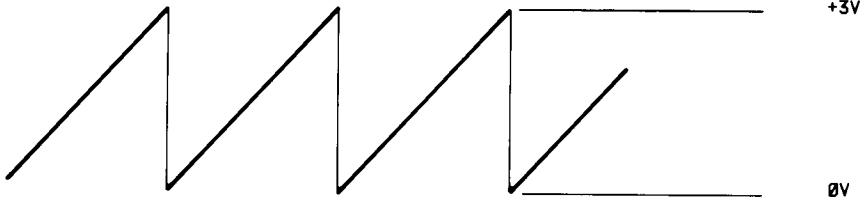

PROBE GROUND  
LEAD ON TP940

38

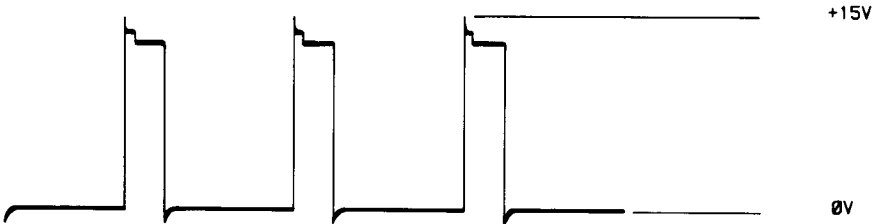

PROBE GROUND  
LEAD ON TP940

39



PROBE GROUND  
LEAD ON TP940

40

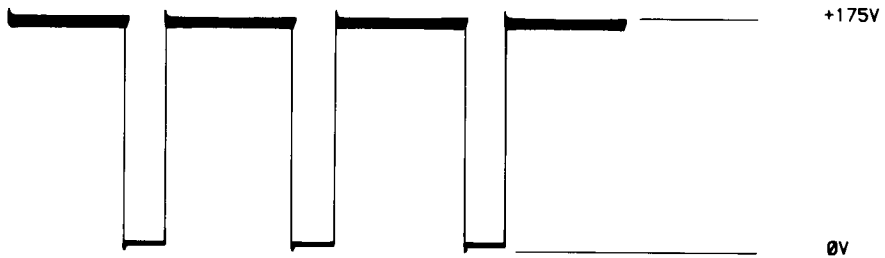

PROBE GROUND  
LEAD ON TP940

41

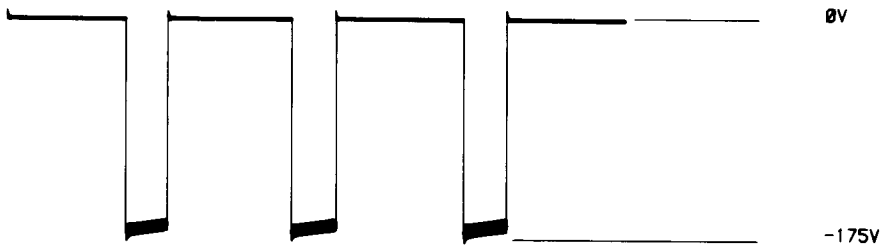

PROBE GROUND  
LEAD ON TP940

VOLTAGE AND  
DUTY CYCLE  
VARY WITH  
INPUT LINE  
VOLTAGE

## AC Waveforms

### WARNING

Instrument must be connected to the ac-power source using a 1:1 isolation transformer. Do not connect the test oscilloscope probe ground lead to the inverter circuit test points if the instrument is not isolated. AC-source voltage exists on reference points TP940 and TP950.

## DC Voltages

Preregulator and Inverter voltages are referenced to test point noted adjacent to the voltage. Power supply output voltages are referenced to chassis ground.

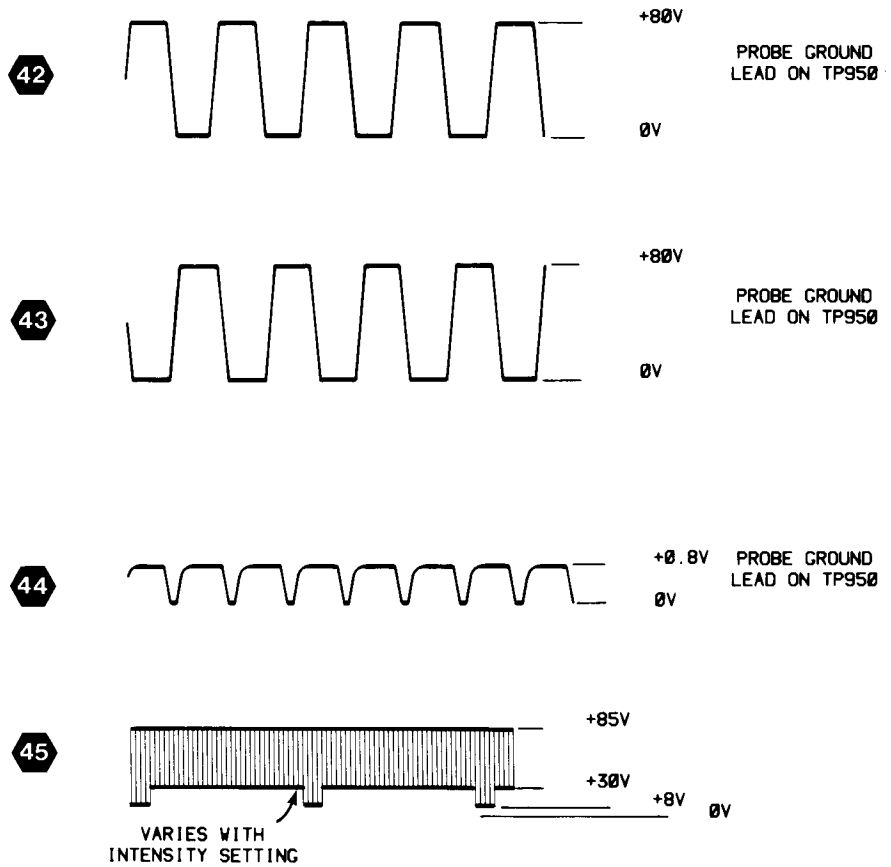

### AC Waveforms

VERTICAL MODE	CH 1
CH 1 VOLTS/DIV	5mV
AC-GND-DC	DC
HORIZONTAL MODE	ALT
A SEC/DIV	50 $\mu$ s
B SEC/DIV	5 $\mu$ s
B DELAY TIME POSITION	5.0
B TRIGGER LEVEL	RUN AFTER DELAY-CW
A TRIGGER Mode	P-P AUTO
A&B INT	CH 1
A SOURCE	INT
CH 1 INPUT SIGNAL	1-kHz sine wave, 5 div.

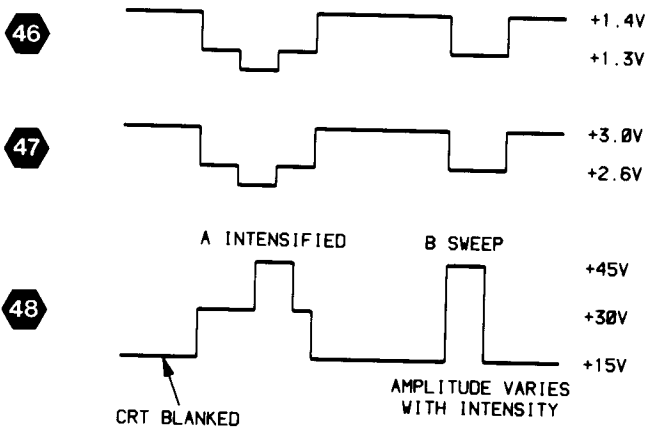

POWER DISTRIBUTION



ASSEMBLY A1								
CIRCUIT NUMBER	SCHEM LOCATION	BOARD LOCATION	CIRCUIT NUMBER	SCHEM LOCATION	BOARD LOCATION	CIRCUIT NUMBER	SCHEM LOCATION	BOARD LOCATION
C200	4H	3E	TP961	7B	8E	W993	9C	5B
C201	8H	3E				W995	9C	6B
C220	4G	2D	W408	9D	7B	W997	4G	4D
C274	3C	2G	W494	4E	5D	W998	8G	4E
C451	8F	6D	W556	6C	2H	W999	8H	2E
C494	4E	5D	W590	7H	7C	W9001-12	5P	5A
C499	8E	5C	W591	6H	7D	W9001-5	4P	5A
C507	6E	6C	W592	6G	8C	W9400-15	6N	7E
C590	6H	7D	W885	7K	4G	W9400-16	6N	7E
C796	8L	2G	W954	1C	6F	W9400-18	6N	7E
C797	4K	3G	W955	1C	4H	W9400-23	6N	7E
C799	2D	3F	W956	2C	5F	W9400-24	6N	7E
			W959	1C	4E	W9400-25	6N	8E
E200	4G	4E	W960	3B	7F	W9400-26	6N	8E
E201	8H	4E	W961	7B	8F	W9400-27	5N	8E
E272	3D	1G	W964	2C	3H	W9400-3	6N	6E
E590	6G	8C	W965	2C	3H	W9700-8	2N	7E
			W968	6D	8F	W9705-1	3N	5E
R220	4H	2D	W971	3C	7E	W9705-4	3N	5E
R451	8E	6D	W972	3C	6E	W9705-6	3N	5E
R494	4D	5E	W974	4J	3H	W9705-7	3N	5E
R499	8E	5E	W975	4K	3H	W9705-8	2N	5E
R796	8K	2G	W976	7C	7E	W9991-1	8N	5E
R797	4K	3G	W977	7D	6E	W9991-2	9N	5E
R799	2C	3E	W979	8K	3H	W9991-3	9N	5E
R964	6B	3H	W991	4C	5B			
R966	6E	7E	W992	4C	5A			

Partial A1 also shown on diagrams 2, 3, 4, 5, 6 and 7.

ASSEMBLY A3								
CIRCUIT NUMBER	SCHEM LOCATION	BOARD LOCATION	CIRCUIT NUMBER	SCHEM LOCATION	BOARD LOCATION	CIRCUIT NUMBER	SCHEM LOCATION	BOARD LOCATION
W89	4P	1C	W9000-12	5N	4B	W9000-5	4N	4A

Partial A3 also shown on diagrams 1, 2, 3, 4, 5, 6 and 7.

A B C D E F G

1  
2  
3  
4  
5  
6  
7  
8  
9

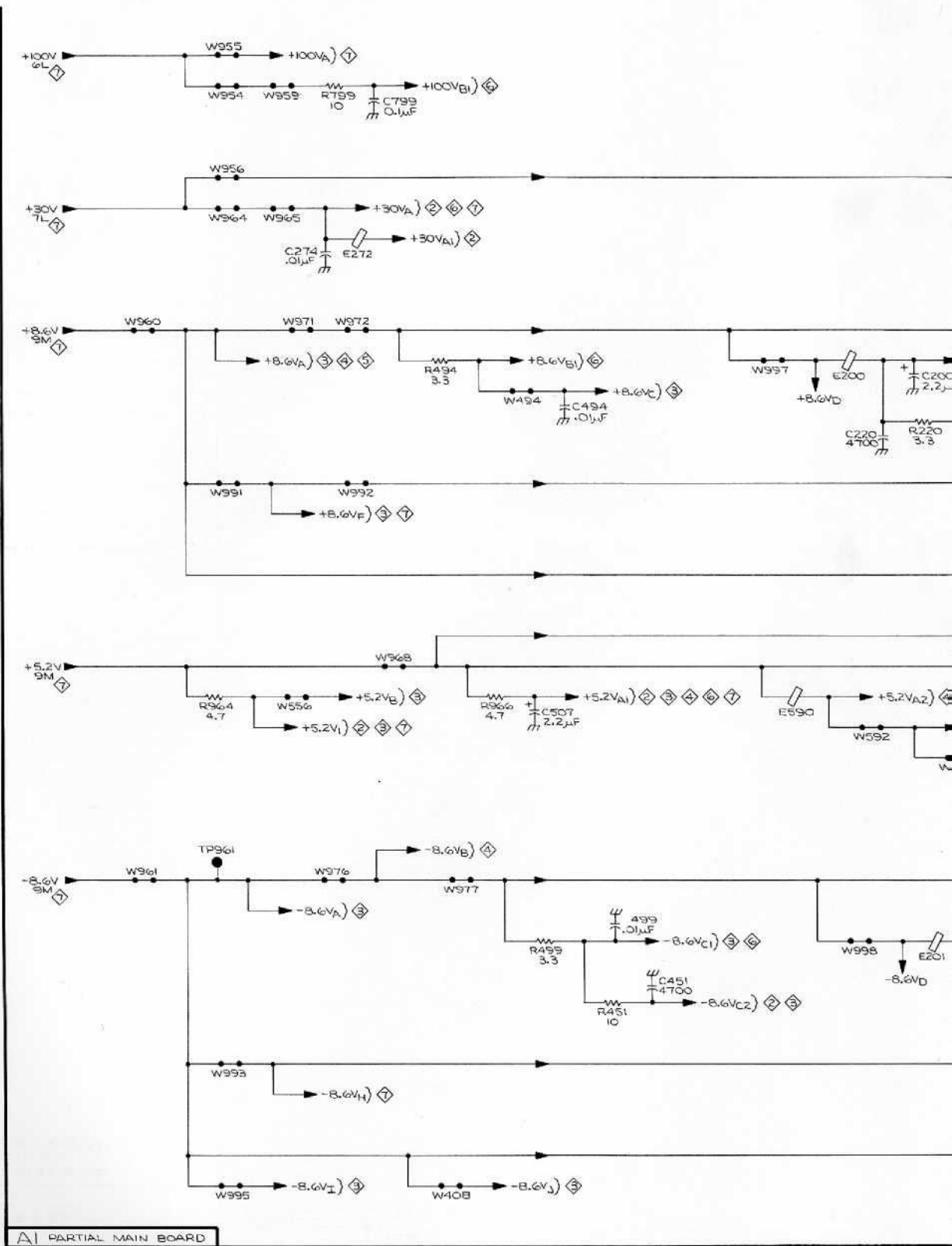

▲ PARTIAL MAIN BOARD

H J K L M N P S

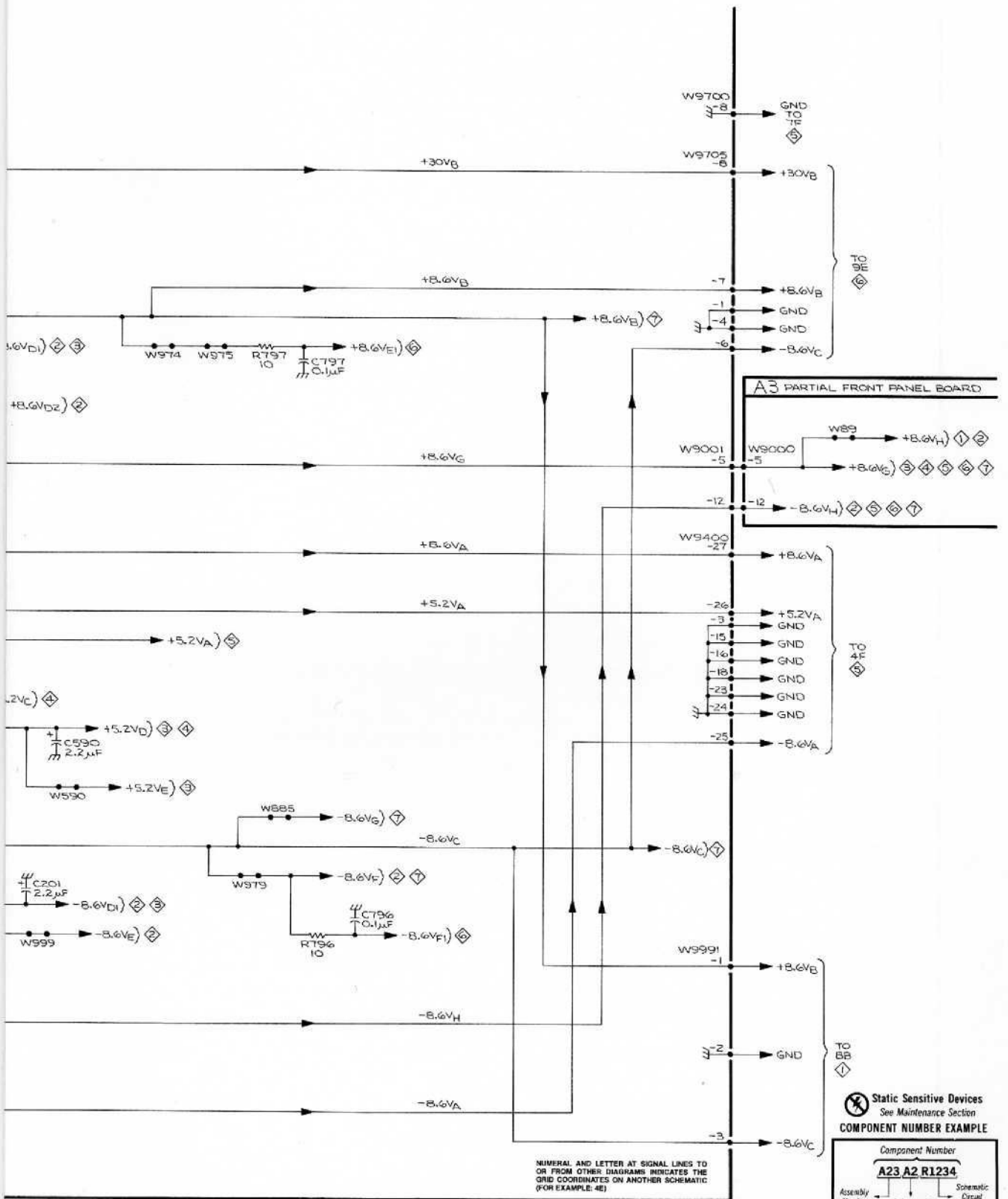

NUMERAL AND LETTER AT SIGNAL LINES TO OR FROM OTHER DIAGRAMS INDICATES THE GRID COORDINATES ON ANOTHER SCHEMATIC (FOR EXAMPLE, 4B)

Static Sensitive Devices  
See Maintenance Section  
COMPONENT NUMBER EXAMPLE

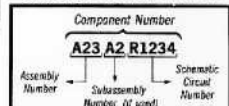

Chassis-mounted components have no Assembly Number prefix—see end of Replaceable Electrical Parts List.

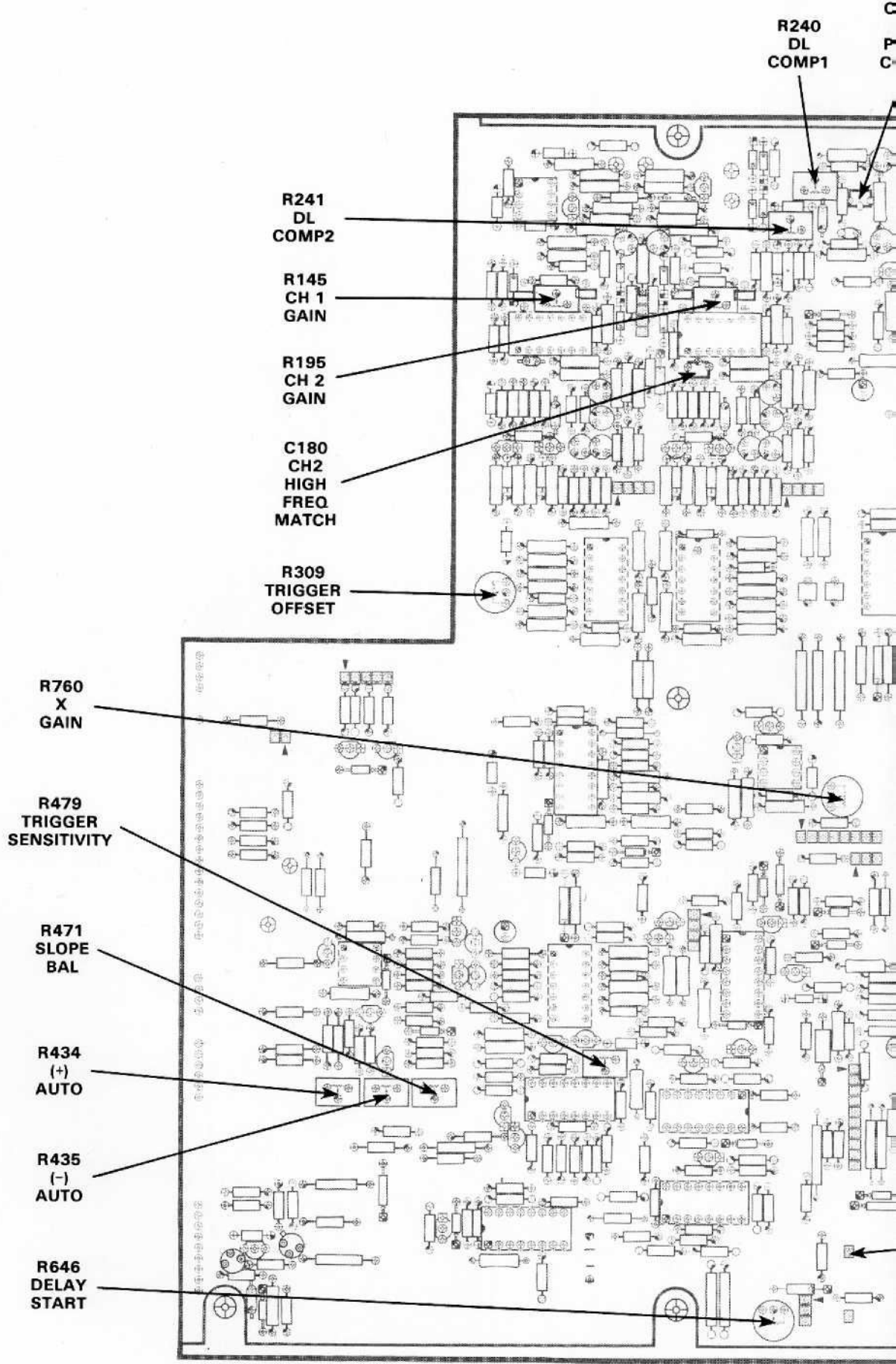

R241  
DL  
COMP2

R145  
CH 1  
GAIN

R195  
CH 2  
GAIN

C180  
CH2  
HIGH  
FREQ  
MATCH

R309  
TRIGGER  
OFFSET

R760  
X  
GAIN

R479  
TRIGGER  
SENSITIVITY

R471  
SLOPE  
BAL

R434  
(+)  
AUTO

R435  
(-)  
AUTO

R646  
DELAY  
START

R240  
DL  
COMP1

R874  
ASTIG

R870  
GEOM

C785  
5-ns  
TIMING

C775  
5-ns  
TIMING

R851  
GRID  
BIAS

W956  
+30V

W954  
+100V

W960  
+8.6V

W968  
+5.2V

TP961  
-8.6V

R938  
-8.6V  
ADJ

ADJUSTMENT LOCATIONS 1

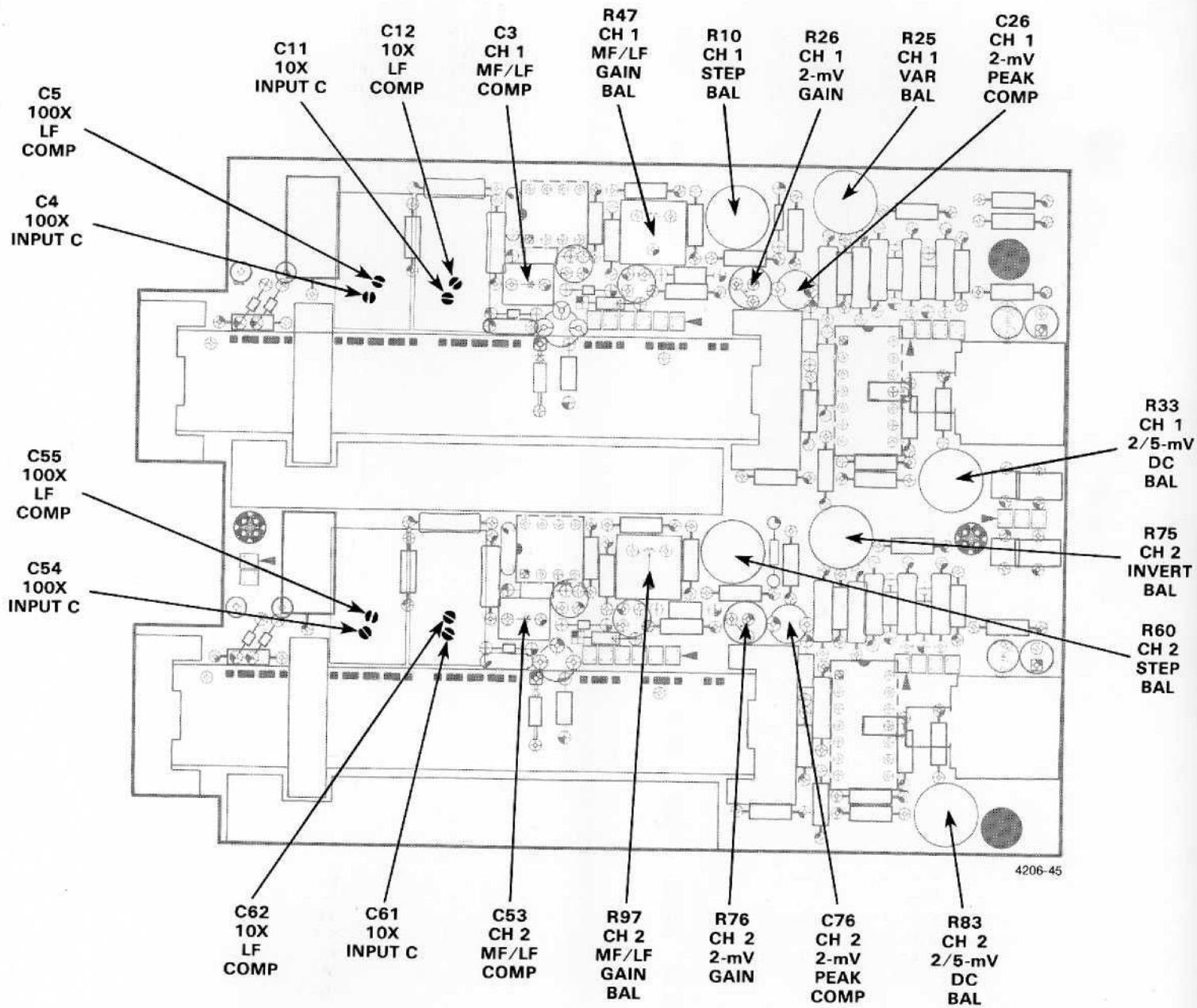

**A2—ATTENUATOR BOARD ADJUSTMENT LOCATIONS**

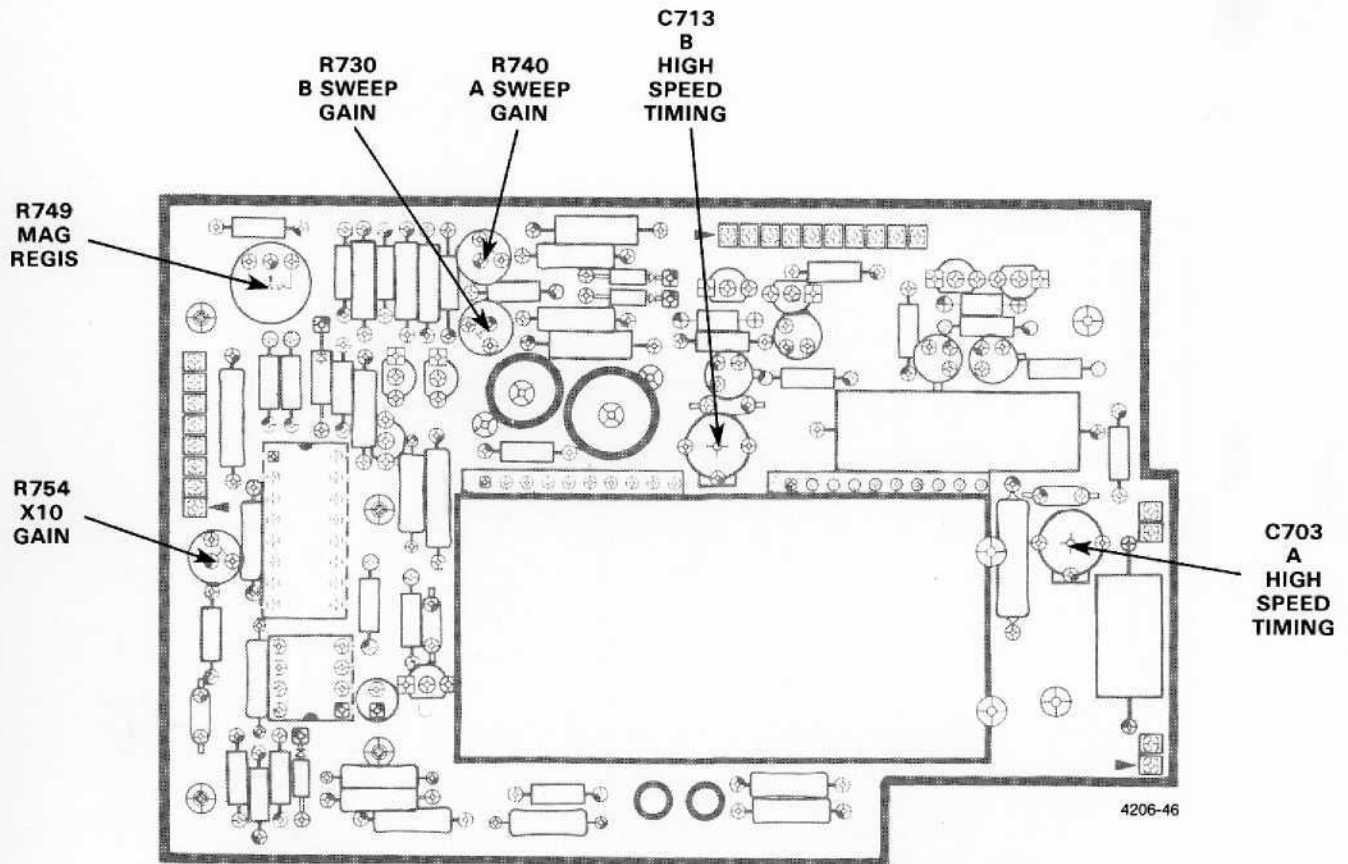

**A4—TIMING BOARD ADJUSTMENT LOCATIONS**

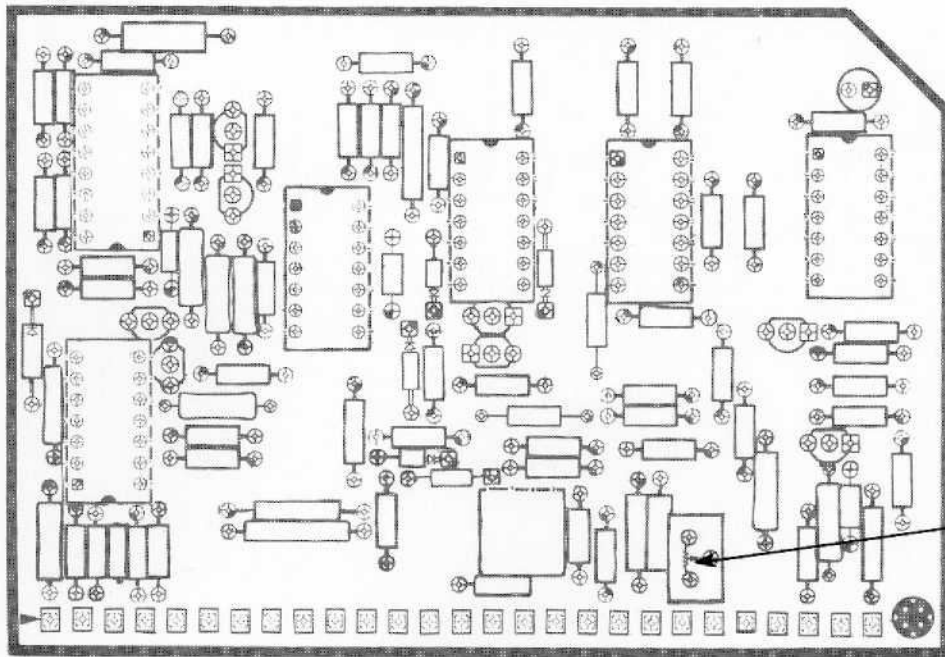

4206-47

**A5—ALT SWEEP LOGIC BOARD ADJUSTMENT LOCATIONS**

I am the original producer of the PDF version of this document.

## GENERAL NOTES

- A. Use schematic diagrams, the overall block diagram, circuit board illustrations, and circuit descriptions when analyzing instrument malfunctions and locating test points. The schematic diagrams include typical waveforms and voltages that are intended as an aid in troubleshooting.
- B. Always set the POWER switch to OFF and unplug the line cord before swapping, removing, or replacing components, and before connecting or disconnecting instrument leads and cables.
- C. When analyzing circuit malfunctions, consider connectors and cables as possible causes of failure.

## SPECIFIC NOTES

1. Set initial front-panel controls as follows:

POWER Switch	ON (button in)
A INTENSITY	Midrange
FOCUS	Midrange
Vertical POSITION	Midrange
VERTICAL MODE	CH 1
CH 1 VOLTS/DIV	0.1V
CH 1 VOLTS/DIV Variable	Cal detent
CH 1 AC-GND-DC	GND
Horizontal POSITION	Midrange
HORIZONTAL MODE	A
A SEC/DIV	0.1ms
A SEC/DIV Variable	Cal detent
X10 Magnifier	Off (knob in)
A TRIGGER Mode	P-P AUTO
A&B INT	VERT MODE
A SOURCE	INT

2. Verify the low-voltage power supplies at the following test points:

SUPPLY	TEST POINT	TOLERANCE
+5.2V	W968	5.04 to 5.36V
+8.6V	W960	8.43 to 8.77V
-8.6V	TP961	-8.56 to -8.64V
+30V	W956	29.1 to 30.9V
+100V	W954	97 to 103V

### NOTE

A HV probe is required to measure the -2kV supply. Turn off the power and make the test equipment connections to the oscilloscope. Set the voltmeter to read at least -3kV, then turn the oscilloscope power back on to take the reading. After obtaining the reading, turn off the oscilloscope power to disconnect the test equipment connections, and replace the crt socket cover.

Verify the -2kV supply at pin 2 of the crt socket. The voltage should be between -1900 and -2100V.

3. **WARNING**

The Preregulator and Inverter circuits have a floating common reference with respect to chassis ground. Ac-source potential is present on the common reference points. Connect the instrument to the ac-power source through an isolation transformer to prevent the possibility of personal injury or equipment damage when troubleshooting these circuits.

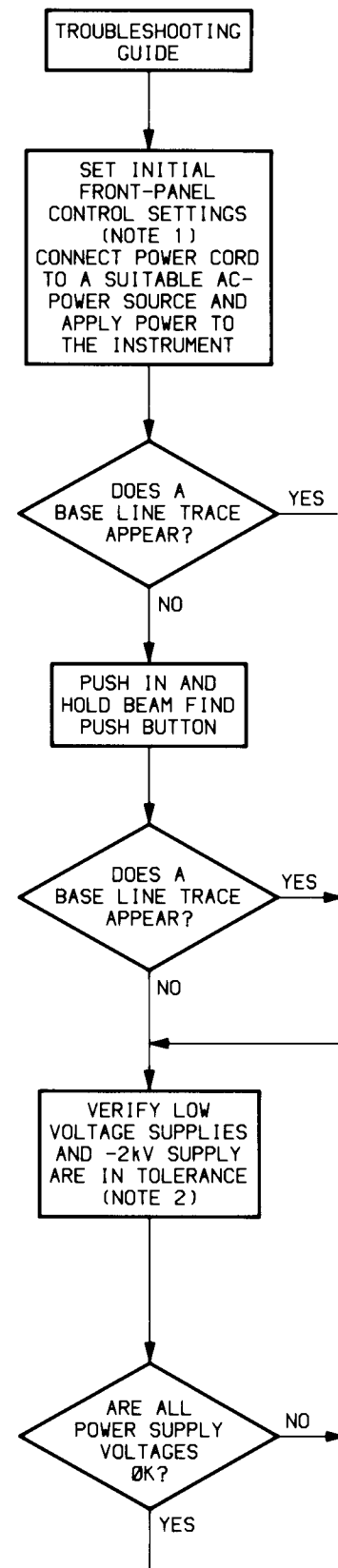

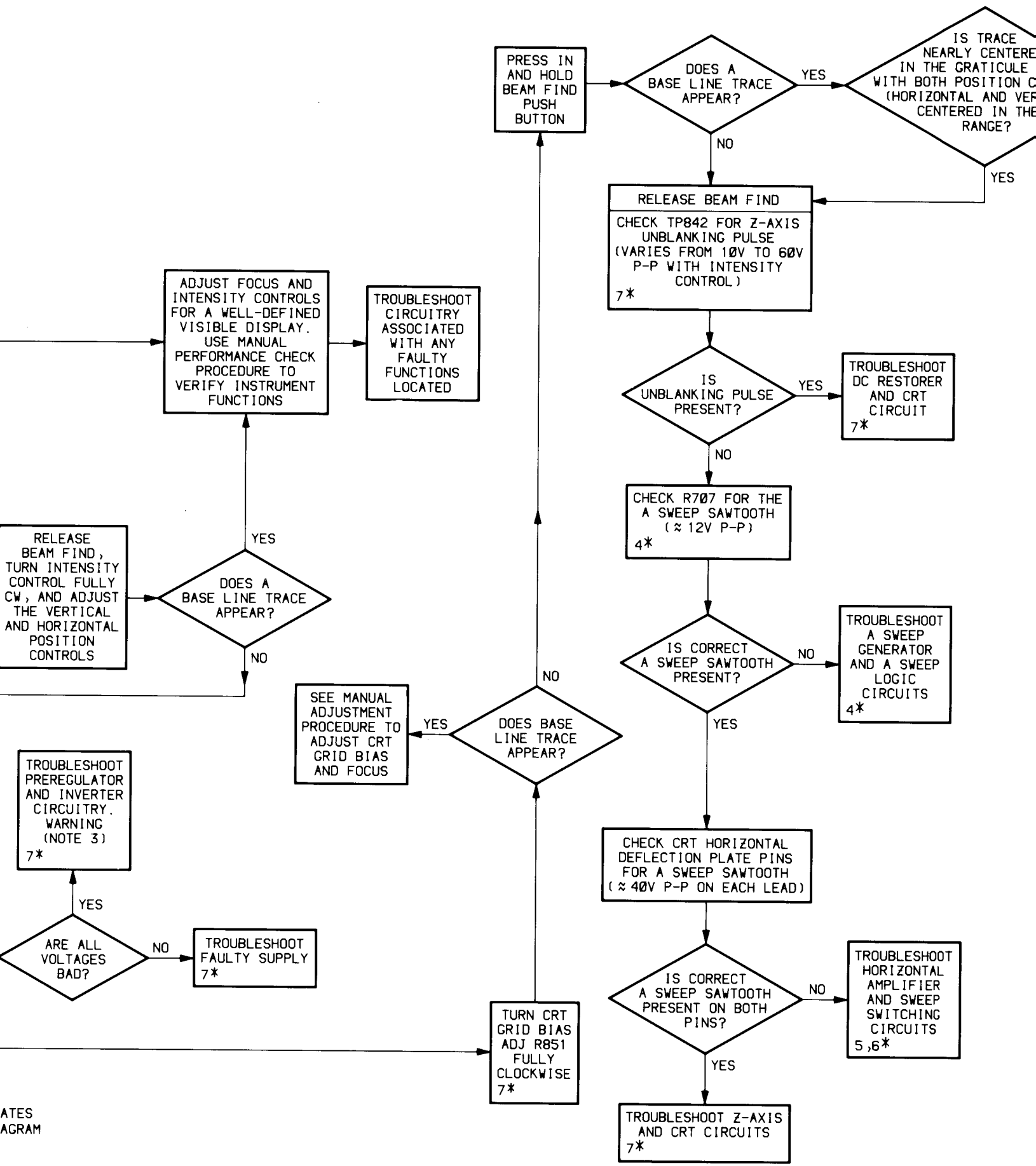

ATES  
AGRAM

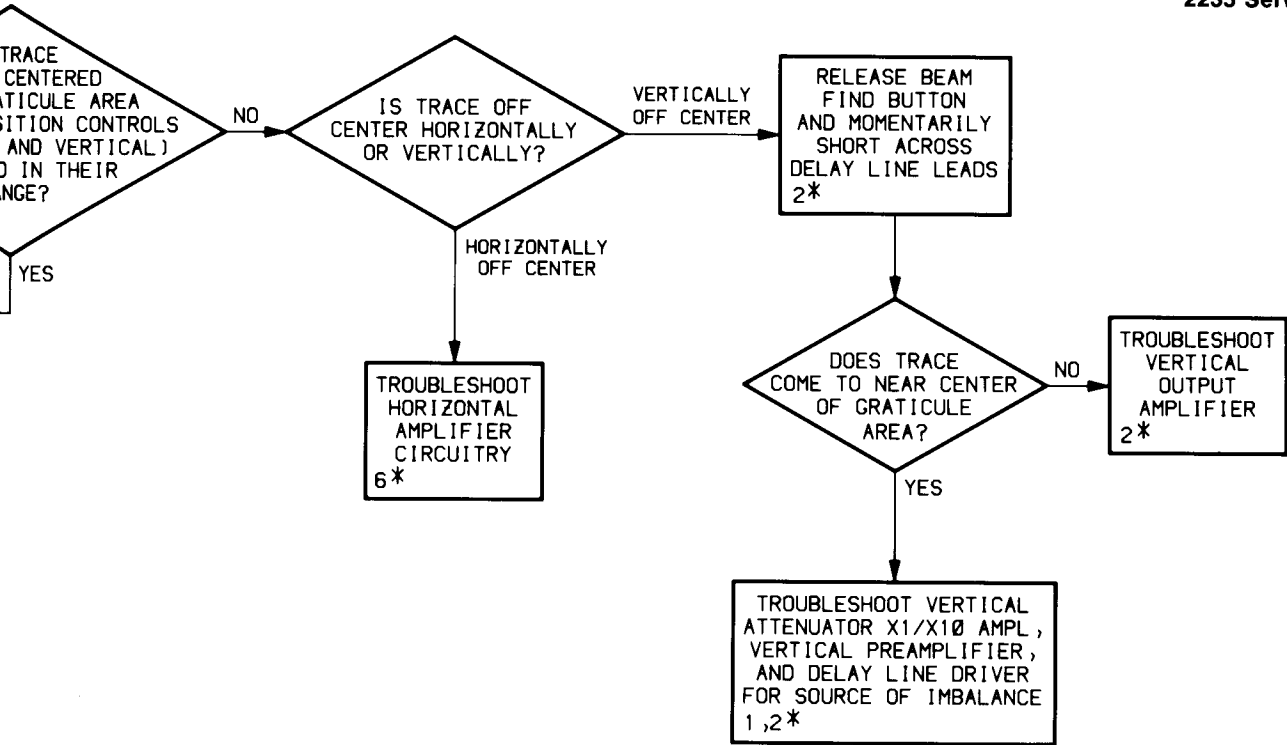

# REPLACEABLE MECHANICAL PARTS

## PARTS ORDERING INFORMATION

Replacement parts are available from or through your local Tektronix, Inc. Field Office or representative.

Changes to Tektronix instruments are sometimes made to accommodate improved components as they become available, and to give you the benefit of the latest circuit improvements developed in our engineering department. It is therefore important, when ordering parts, to include the following information in your order: Part number, instrument type or number, serial number, and modification number if applicable.

If a part you have ordered has been replaced with a new or improved part, your local Tektronix, Inc. Field Office or representative will contact you concerning any change in part number.

Change information, if any, is located at the rear of this manual.

## SPECIAL NOTES AND SYMBOLS

X000 Part first added at this serial number  
00X Part removed after this serial number

## FIGURE AND INDEX NUMBERS

Items in this section are referenced by figure and index numbers to the illustrations.

## INDENTATION SYSTEM

This mechanical parts list is indented to indicate item relationships. Following is an example of the indentation system used in the description column.

```

1 2 3 4 5           Name & Description
Assembly and/or Component
Attaching parts for Assembly and/or Component
    --- * ---
Detail Part of Assembly and/or Component
Attaching parts for Detail Part
    --- * ---
Parts of Detail Part
Attaching parts for Parts of Detail Part
    --- * ---
  
```

Attaching Parts always appear in the same indentation as the item it mounts, while the detail parts are indented to the right. Indented items are part of, and included with, the next higher indentation. The separation symbol --- \* --- indicates the end of attaching parts.

**Attaching parts must be purchased separately, unless otherwise specified.**

## ITEM NAME

In the Parts List, an Item Name is separated from the description by a colon (:). Because of space limitations, an Item Name may sometimes appear as incomplete. For further Item Name identification, the U.S. Federal Cataloging Handbook H6-1 can be utilized where possible.

## ABBREVIATIONS

INCH	ELECTRN	ELECTRON	IN	INCH	SE	SINGLE END
#	ELEC	ELECTRICAL	INCAND	INCANDESCENT	SECT	SECTION
ACTR	ELCTLT	ELECTROLYTIC	INSUL	INSULATOR	SEMICOND	SEMICONDUCTOR
ADPTR	ELEM	ELEMENT	INTL	INTERNAL	SHLD	SHIELD
ALIGN	EPL	ELECTRICAL PARTS LIST	LPHLDR	LAMPHOLDER	SHLDR	SHOULDERED
AL	EQPT	EQUIPMENT	MACH	MACHINE	SKT	SOCKET
ASSEM	EXT	EXTERNAL	MECH	MECHANICAL	SL	SLIDE
ASSY	FIL	FILLISTER HEAD	MTG	MOUNTING	SLFLKG	SELF-LOCKING
ATTEN	FLEX	FLEXIBLE	NIP	NIPPLE	SLVG	SLEEVING
AWG	FLH	FLAT HEAD	NON WIRE	NOT WIRE WOUND	SPR	SPRING
BD	FLTR	FILTER	OBD	ORDER BY DESCRIPTION	SQ	SQUARE
BRKT	FR	FRAME or FRONT	OD	OUTSIDE DIAMETER	SST	STAINLESS STEEL
BRS	FRSTNR	FASTENER	OVH	OVAL HEAD	STL	STEEL
BRZ	FT	FOOT	PH BRZ	PHOSPHOR BRONZE	SW	SWITCH
BSHG	FXD	FIXED	PL	PLAIN or PLATE	T	TUBE
CAB	GSKT	GASKET	PLSTC	PLASTIC	TERM	TERMINAL
CAP	HDL	HANDLE	PN	PART NUMBER	THD	THREAD
CER	HEX	HEXAGON	PNH	PAN HEAD	THK	THICK
CHAS	HEX HD	HEXAGONAL HEAD	PWR	POWER	TNSN	TENSION
CKT	HEX SOC	HEXAGONAL SOCKET	RCPT	RECEPTACLE	TPG	TAPPING
COMP	HLCPS	HELICAL COMPRESSION	RES	RESISTOR	TRH	TRUSS HEAD
CONN	HLEXT	HELICAL EXTENSION	RGD	RIGID	V	VOLTAGE
COV	HV	HIGH VOLTAGE	RLF	RELIEF	VAR	VARIABLE
CPLG	IC	INTEGRATED CIRCUIT	RTNR	RETAINER	W/	WITH
CRT	ID	INSIDE DIAMETER	SCH	SOCKET HEAD	WSHR	WASHER
DEG	IDENT	IDENTIFICATION	SCOPE	OSCILLOSCOPE	XFMR	TRANSFORMER
DWR	IMPLR	IMPELLER	SCR	SCREW	XSTR	TRANSISTOR

# Replaceable Mechanical Parts—2235 Service

## CROSS INDEX—MFR. CODE NUMBER TO MANUFACTURER

Mfr. Code	Manufacturer	Address	City, State, Zip
00779	AMP, INC.	P O BOX 3608	HARRISBURG, PA 17105
01536	CAMCAR DIV OF TEXTRON INC. SEMS PRODUCTS UNIT	1818 CHRISTINA ST.	ROCKFORD, IL 61108
02768	ILLINOIS TOOL WORKS, INC., FASTEX DIV.	195 ALGONQUIN ROAD	DES PLAINES, IL 60016
05129	KILO ENGINEERING COMPANY	2015 D	LA VERNE, CA 91750
06383	PANDUIT CORPORATION	17301 RIDGELAND	TINLEY PARK, IL 60477
12327	FREEWAY CORPORATION	9301 ALLEN DRIVE	CLEVELAND, OH 44125
12697	CLAROSTAT MFG. CO., INC.	LOWER WASHINGTON STREET	DOVER, NH 03820
13511	AMPHENOL CARDRE DIV., BUNKER RAMO CORP.		LOS GATOS, CA 95030
16428	BELDEN CORP.	P. O. BOX 1331	RICHMOND, IN 47374
22526	BERG ELECTRONICS, INC.	YOUK EXPRESSWAY	NEW CUMBERLAND, PA 17070
24931	SPECIALITY CONNECTOR CO., INC.	2620 ENDRESS PLACE	GREENWOOD, IN 46142
71400	BUSSMAN MFG., DIVISION OF MCGRAW-EDISON CO.	2536 W. UNIVERSITY ST.	ST. LOUIS, MO 63107
73743	FISCHER SPECIAL MFG. CO.	446 MORGAN ST.	CINCINNATI, OH 45206
77820	BENDIX CORP., THE, ELECTRICAL COMPONENTS DIVISION	SHERMAN AVE.	SIDNEY, NY 13838
78189	ILLINOIS TOOL WORKS, INC. SHAKEPROOF DIVISION	ST. CHARLES ROAD	ELGIN, IL 60120
80009	TEKTRONIX, INC.	P O BOX 500	BEAVERTON, OR 97077
80126	PACIFIC ELECTRICORD CO.	747 W. REDONDO BEACH, P O BOX 10	GARDENA, CA 90247
83385	CENTRAL SCREW CO.	2530 CRESCENT DR.	BROADVIEW, IL 60153
89663	REESE, J. RAMSEY, INC.	71 MURRAY STREET	NEW YORK, NY 10007
93907	TEXTRON INC. CAMCAR DIV	600 18TH AVE	ROCKFORD, IL 61101
S3109	C/O PANEL COMPONENTS CORP.	P.O. BOX 6626	SANTA ROSA, CA 95406
S3629	PANEL COMPONENTS CORP.	2015 SECOND ST.	BERKELEY, CA 94170

Replaceable Mechanical Parts—2235 Service

Fig. & Index No.	Tektronix Part No.	Serial/Model No.		Qty						Name & Description	Mfr	
		Eff	Dscont		1	2	3	4	5		Code	Mfr Part Number
1-1	334-5001-06			1						MARKER,IDENT:MARKED CAUTION U.S.A.	80009	334-5001-06
	334-5001-07			1						MARKER,IDENT:MARKED CAUTION U.K.	80009	334-5001-07
-2	200-2538-00			1						COVER,REAR:PLASTIC ***** (ATTACHING PARTS) *****	80009	200-2538-00
-3	211-0691-00			2						SCREW,MACHINE:6-32 X 0.625,PNH ***** (END ATTACHING PARTS) *****	01536	OBD
-4	213-0882-00			1						SCREW,TAPPING:6-32 X 0.437 TYPE C	01536	OBD
-5	334-4714-00			1						MARKER,IDENT:MARKED HANDLE TAG	80009	334-4714-00
-6	367-0289-00			1						HANDLE,CARRYING:13.855,SST ***** (ATTACHING PARTS) *****	80009	367-0289-00
-7	212-0144-00			2						SCREW,TPG,TF:8-16 X 0.562 L ***** (END ATTACHING PARTS) *****	93907	225-38131-012
-8	390-0790-06			1						CABINET,SCOPE:W/FEET	80009	390-0790-00

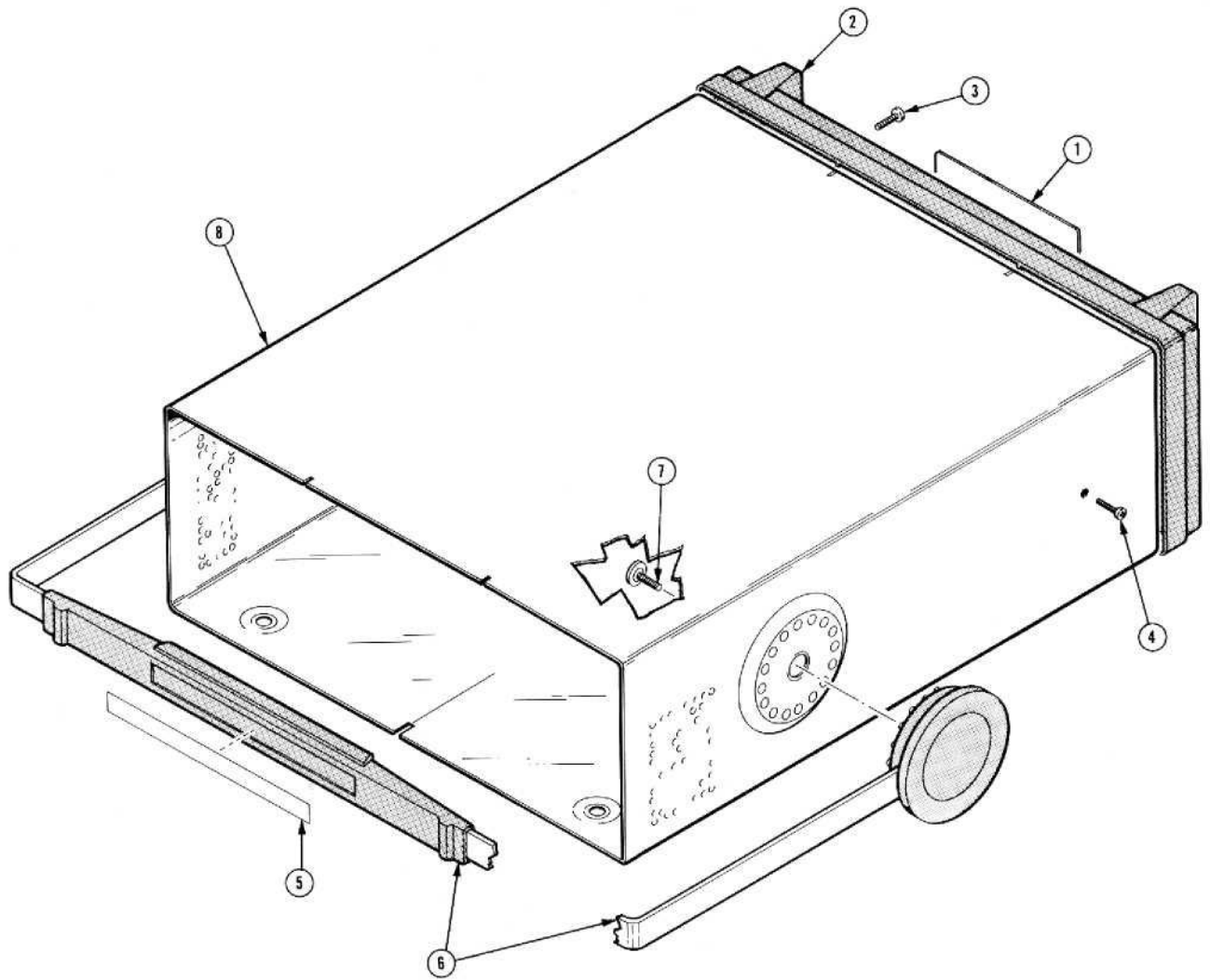
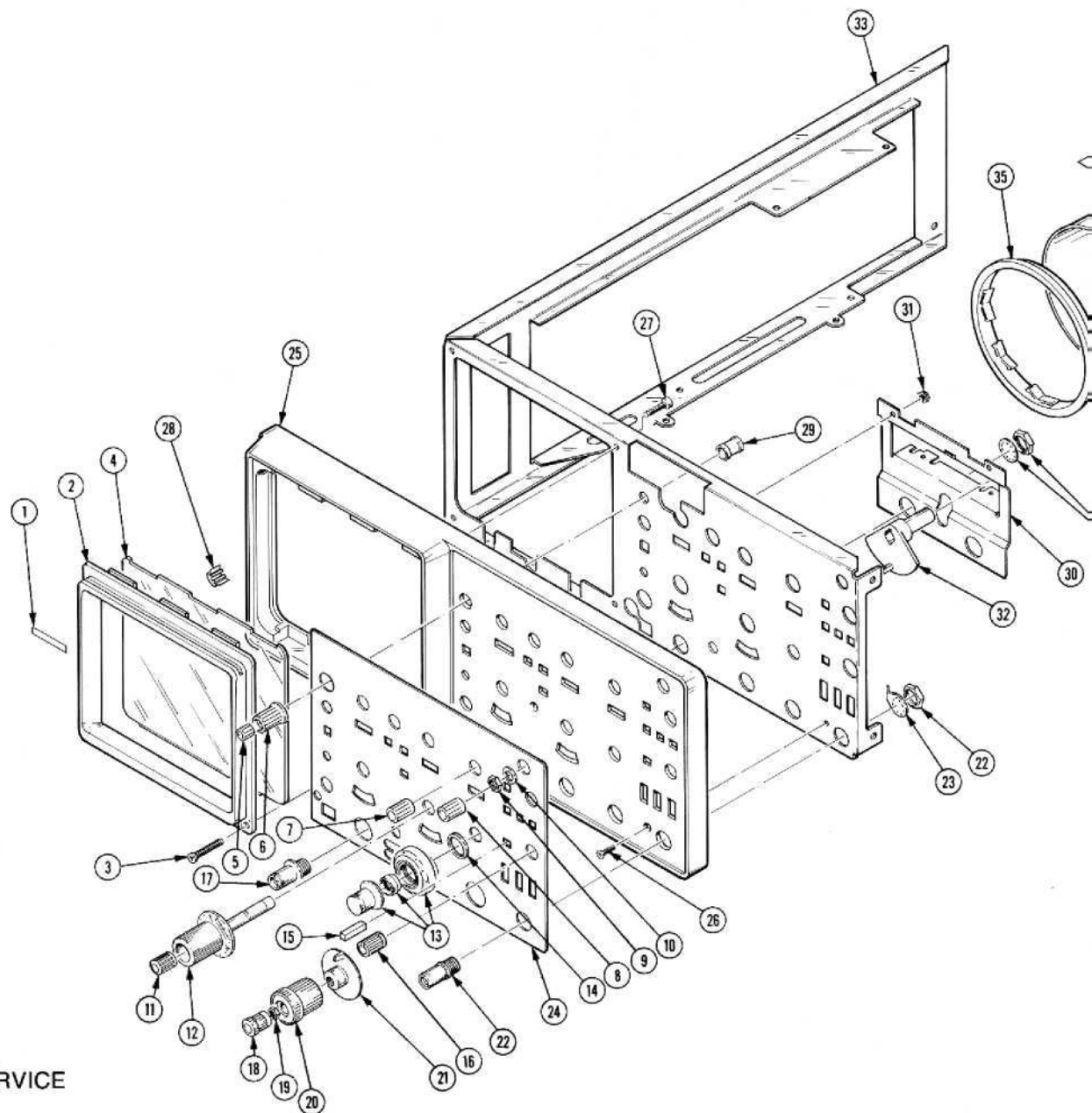

FIG. 2 LEFT & RIGHT SIDES



2235 SERVICE

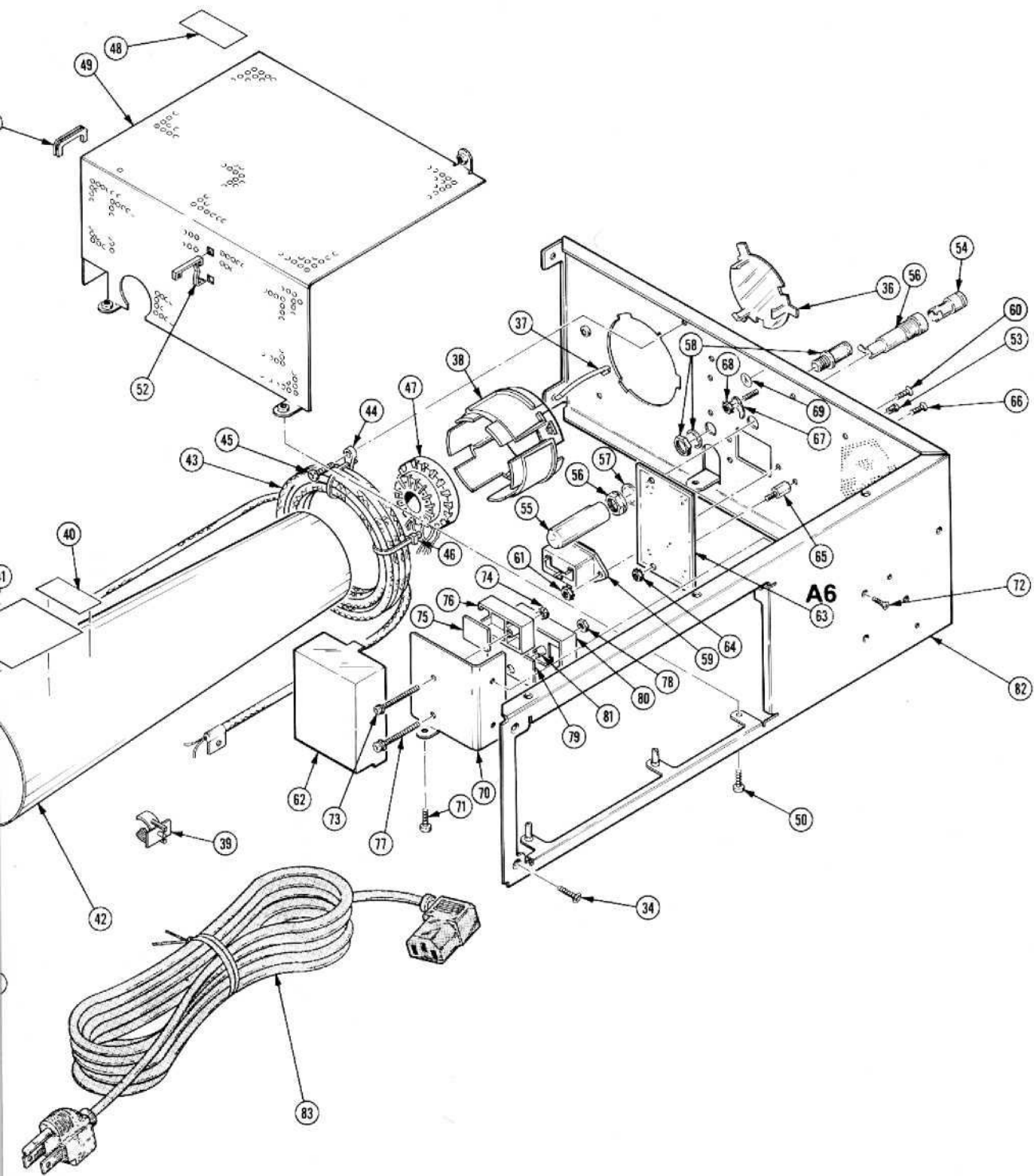

Fig. & Index No.	Tektronix Part No.	Serial/Model No.		Qty	1 2 3 4 5					Name & Description	Mfr Code	Mfr Part Number
		Eff	Dscont									
2-1	334-5002-00			1						PLATE,IDENT:MKD TEKTRONIX	80009	334-5002-00
-2	426-1765-00			1						FRAME,CRT: ***** (ATTACHING PARTS)*****	80009	426-1765-00
-3	211-0690-01			2						SCREW,MACHINE:6-32 X 0.875 PNH,TORX DR,SLO ***** (END ATTACHING PARTS)*****	93907	OBD
-4	337-2775-00			1						SHLD,IMPLOSION:	80009	337-2775-00
-5	366-1391-03			1						KNOB:DOVE GRAY,0.081 ID X 0.28 OD X 0.32 H	80009	366-1391-03
-6	366-2146-03			1						KNOB:DOVE GRAY,0.235 ID X 0.5 OD X 0.531 H	80009	366-2146-03
-7	366-1833-01			4						KNOB:DOVE GRAY,0.25 ID X 0.392 OD X 0.466	80009	366-1833-01
-8	366-1701-01			1						KNOB:GY,0.127 ID X 0.392 OD X 0.	80009	366-1701-01
-9	210-0583-00			1						NUT,PLAIN,HEX:0.25-32 X 0.312 INCH,BRS	73743	2X20317-402
-10	210-0021-00			1						WASHER,LOCK:INTL,0.476 ID X 0.60" OD ST	78189	1222-01-00-0541C
-11	366-2152-00			2						KNOB:DOVE GRAY,0.284 ID X 0.392 OD X 0.466	80009	366-2152-00
-12	366-2148-01			2						KNOB:GY,VOLTS/DIV 0.72 OD,0.79H	80009	366-2148-01
-13	331-0328-00			1						DIAL,CONTROL:10 TURN FOR 0.25 DIA SHAFT	05129	461-S-70
-14	210-0840-00			1						WASHER,FLAT:0.39 ID X 0.562 INCH OD,STL	89663	644R
-15	366-2013-00			9						PUSH,BUTTON:DIRTY GRAY,0.134 SQ X 0.480	80009	366-2013-00
-16	366-2049-00			2						KNOB:GY,0.712 ID X 0.41 OD X 0.496 H,W/BAR	80009	366-2049-00
-17	131-0126-00			2						CONNECTOR,RCPT.:BNC,FEMALE	77820	9663-1 NT-34
-18	366-2151-01			1						KNOB:FLINT GRAY,0.22 ID X 0.392 OD X 0.466	80009	366-2151-01
-19	210-0583-00			1						NUT,PLAIN,HEX:0.25-32 X 0.312 INCH,BRS	73743	2X20317-402
-20	366-1840-02			1						KNOB:GY,TIME/DIV,0.127 ID X 0.855	80009	366-1840-02
-21	366-1850-00			1						KNOB:CLEAR,0.252 ID X 1.2 OD X 0	80009	366-1850-00
-22	131-0955-00			1						CONN,RCPT,ELEC:BNC,FEMALE	13511	31-279
-23	210-0255-00			1						TERMINAL,LUG:0.391 ID,LOCKING,BRS CD PL	80009	210-0255-00
-24	333-2918-00			1						PANEL,FRONT:	80009	333-2918-00
-25	386-4850-00			1						SUBPANEL,FRONT: ***** (ATTACHING PARTS)*****	80009	386-4850-00
-26	213-0881-00			3						SCREW,TAPPING:6-32 X 0.25 TYPE C	01536	OBD
-27	213-0882-00			2						SCREW,TAPPING:6-32 X 0.437 TYPE C ***** (END ATTACHING PARTS)*****	01536	OBD
-28	348-0660-00			4						CUSHION,CRT:POLYURETHANE	80009	348-0660-00
-29	361-1192-00			1						SPACER,SLEEVE:0.45 L X 0.25 ID,AL	80009	361-1192-00
-30	407-2824-00			1						BRACKET,GROUND:PANEL ***** (ATTACHING PARTS)*****	80009	407-2824-00
-31	210-0586-00			2						NUT,PL,ASSEM WA:4-40 X 0.25,STL ***** (END ATTACHING PARTS)*****	83385	OBD
-32	214-3375-00			2						LEVER,SWITCH:AC-GND-DC,PLASTIC	80009	214-3375-00
-33	441-1631-00			1						CHASSIS,SCOPE:FRONT	80009	441-1631-00
-34	213-0881-00			4						SCREW,TAPPING:6-32 X 0.25 TYPE C	01536	OBD
-35	386-4443-00			1						SUPPORT,SHIELD:CRT,FRONT,PLASTIC	80009	386-4443-00
-36	200-2519-00			1						CAP.,CRT SOCKET:NATURAL LEXAN	80009	200-2519-00
-37	214-1061-05			1						SPRING,GROUND:PLATED	80009	214-1061-05
-38	426-1766-00			1						MOUNT,RESILIENT:CRT,REAR	80009	426-1766-00
-39	344-0347-00			1						CLIP,ELECTRICAL:ANODE,0.72 OD,NYLON	80009	344-0347-00
-40	334-1379-00			1						LABEL:CRT,ADHESIVE BACK	80009	334-1379-00
-41	334-1951-00			1						MARKER,IDENT:CRT WARNING	80009	334-1951-00
-42	337-2774-00			1						SHIELD,ELEC:CRT,STEEL	80009	337-2774-00
-43	-----			1						DELAY LINE,ELEC:93NS,150 OHM,ASSY (SEE DL9210 CHASSIS REPL)		
-44	346-0121-00			2						STRAP,ELEC COMP:TIE DOWN,5.0 LONG ***** (ATTACHING PARTS)*****	06383	PLC1.5I-S8
-45	213-0882-00			2						SCREW,TAPPING:6-32 X 0.437 TYPE C ***** (END ATTACHING PARTS)*****	01536	OBD
-46	346-0128-00			1						STRAP,TIE DOWN:0.1W X 8.0" LONG,NYLON	06383	PLT2M
-47	136-0202-08			1						SKT,PL-IN ELEK:ELECTRON TUBE,14 CONTACT	80009	136-0202-08
-48	334-4251-00			1						MARKER,IDENT:MKD CAUTION	80009	334-4251-00
-49	337-2772-00			1						SHIELD,ELEC:POWER SUPPLY,AL ***** (ATTACHING PARTS)*****	80009	337-2772-00
-50	211-0304-00			3						SCREW,MACHINE:4-40 X 0.312,PNH ***** (END ATTACHING PARTS)*****	01536	OBD
-51	348-0555-00			1						GROMMET,PLASTIC:SIL GY,U SHAPE,0.52 ID	80009	348-0555-00
-52	344-0334-00			1						CLIP,CIRCUIT BD:PLASTIC	80009	344-0334-00

# Replaceable Mechanical Parts—2235 Service

Fig. & Index No.	Tektronix Part No.	Serial/Model No. Eff Dscont	Qty	1 2 3 4 5	Name & Description	Mfr Code	Mfr Part Number
2-53	134-0158-00		2		BUTTON,PLUG:0.187 DIA,NYLON	02768	207-080501-00
-54	200-2264-00		1		CAP.,FUSEHOLDER:3AG FUSES	S3629	FEK 031 1666
-55	200-1388-03		1		COVER,FUSE,LEAD:POLYURETHANE	80009	200-1388-03
-56	204-0833-00		1		BODY,FUSEHOLDER:3AG & 5 X 20MM FUSES	S3629	031.1653(MDLFEU)
-57	210-1039-00		1		WASHER,LOCK:INT.0.521 ID X 0.625 INCH O	24931	OBD
-58	131-0955-00		1		CONN,RCPT,ELEC:BNC,FEMALE	13511	31-279
-59	-----		1		FILTER,RFI:1A,250VAC		
	-----		-		(SEE FL9001 CHASSIS REPL)		
					*****ATTACHING PARTS*****		
-60	211-0323-00		2		SCREW,MACHINE:4-40 X 0.312,FLH,100 DEG	83385	OBD
-61	210-0583-00		2		NUT,PLAIN,HEX:0.25-32 X 0.312 INCH,BRS	73743	2X20317-402
					*****END ATTACHING PARTS*****		
-62	200-2845-00		1		COVER,CKT BD:LINE FILTER	80009	200-2845-00
-63	670-7615-00		1		CKT BOARD ASSY:EMI FILTER BOARD	80009	670-7615-00
	-----		-		(SEE A6 REPL)		
					*****ATTACHING PARTS*****		
-64	210-0586-00		2		NUT,PL,ASSEM WA:4-40 X 0.25,STL	83385	OBD
					*****END ATTACHING PARTS*****		
-65	129-0339-00		2		POST,ELEC-MECH:0.27 LONG X 0.25 HEX BRS	80009	129-0339-00
					*****ATTACHING PARTS*****		
-66	211-0303-00		2		SCREW,MACHINE:4-40 X 0.25,FLH 100 DEG	01536	OBD
					*****END ATTACHING PARTS*****		
-67	210-0202-00		1		TERMINAL,LUG:0.146 ID,LOCKING,BRZ TINNED	78189	2104-06-00-2520N
					*****ATTACHING PARTS*****		
-68	210-0457-00		1		NUT,PL,ASSEM WA:6-32 X 0.312,STL CD PL	83385	OBD
					*****END ATTACHING PARTS*****		
-69	334-3379-02		1		MARKER,IDENT:MARKED GROUND SYMBOL	80009	334-3379-02
-70	407-2729-00		1		BRACKET,HEAT SK:AL	80009	407-2729-00
					*****ATTACHING PARTS*****		
-71	211-0304-00		1		SCREW,MACHINE:4-40 X 0.312,PNH	01536	OBD
-72	210-0586-00		2		NUT,PL,ASSEM WA:4-40 X 0.25,STL	83385	OBD
					*****END ATTACHING PARTS*****		
-73	211-0302-00		1		SCREW,MACHINE:4-40 X 0.75,PNH	01536	OBD
-74	210-0586-00		1		NUT,PL,ASSEM WA:4-40 X 0.25,STL	83385	OBD
-75	342-0582-01		1		INSULATOR,PLATE:TRANSISTOR,CERAMIC	80009	342-0582-01
-76	343-1025-00		1		RETAINER,XSTR:	80009	343-1025-00
-77	211-0691-00		1		SCREW,MACHINE:6-32 X 0.625,PNH	01536	OBD
-78	210-0408-00		1		NUT,PLAIN,HEX.:6-32 X 0.312 INCH,BRS	73743	3040-402
-79	342-0555-00		1		INSULATOR,PLATE:HEAT SINK,AL	80009	342-0555-00
-80	343-0969-00		1		RETAINER,XSTR:POLYPHENYLENE SULFIDE	80009	343-0969-00
-81	361-1047-00		1		SPACER,VAR RES:0.3 X 0.615 X 0.55	80009	361-1047-00
-82	441-1536-01		1		CHASSIS,SCOPE:REAR	80009	441-1536-01
-83	161-0104-00		1		CABLE ASSY,PWR.:3 WIRE,98.0" LONG	16428	KH8352
	-----		-		(ALSO SEE STANDARD ACCESSORIES)		
	161-0104-06		1		CABLE ASSY,PWR:3 X 0.75MM SQ,220V,98.0L	S3109	OBD
	-----		-		(OPTION A1 EUROPEAN)		
	161-0104-07		1		CABLE ASSY,PWR:3 X 0.75MM SQ,240V,98.0 L	80126	OBD
	-----		-		(OPTION A2 UNITED KINGDOM)		
	161-0104-05		1		CABLE ASSY,PWR:3.18 AWG,240V,98.0 L	S3109	OBD
	-----		-		(OPTION A3 AUSTRALIAN)		
	161-0104-08		1		CABLE ASSY,PWR:3.18 AWG,240V,98.0 L	80126	OBD
	-----		-		(OPTION A4 NORTH AMERICAN)		
	161-0167-00		1		CABLE ASSY,PWR:3.0 X 0.75,6A,240V,2.5M	S3109	OBD
	-----		-		(OPTION A5)		

Replaceable Mechanical Parts—2235 Service

Fig. & Index No.	Tektronix Part No.	Serial/Model No.		Qty	Name & Description					Mfr Code	Mfr Part Number
		Eff	Dscont		1	2	3	4	5		
3-1	334-4251-00			1						80009	334-4251-00
-2	337-2773-00			1						80009	337-2773-00
-3	211-0304-00			1						01536	OBD
-4	366-1480-02			1						80009	366-1480-02
-5	384-1576-01			1						80009	384-1576-01
-6	200-2735-00			1						80009	200-2735-00
-7	-----			1							
	-----			-							
-8	377-0512-00			6						80009	377-0512-00
-9	670-7611-00			1						80009	670-7611-00
	-----			-							
-10	131-0608-00			2						22526	47357
-11	136-0499-02			3						00779	3-380949-2
-12	670-7612-00			1						80009	670-7612-00
	-----			-							
-13	131-0589-00			27						22526	48283-029
-14	670-7560-00			1						80009	670-7560-00
	-----			-							
-15	131-0608-00			3						22526	47357
-16	131-0589-00			7						22526	48283-029
-17	343-0088-00			1						80009	343-0088-00
	672-1064-00			1						80009	672-1064-00
-18	346-0196-00			1						80009	346-0196-00
-19	211-0325-00			2						01536	OBD
-20	210-0801-00			1						12327	OBD
-21	361-1191-00			1						80009	361-1191-00
-22	337-3014-00			1						80009	337-3014-00
-23	211-0325-00			1						01536	OBD
-24	211-0326-00			2						93907	OBD
-25	670-7561-00			1						80009	670-7561-00
	-----			-							
-26	211-0325-00			1						01536	OBD
-27	129-0986-00			1						80009	129-0986-00
-28	384-1056-00			2						80009	384-1056-00
	376-0209-00			2						80009	376-0209-00
-29	401-0370-00			4						80009	401-0370-00
-30	210-0406-00			4						73743	12161-50
-31	214-1126-01			6						80009	214-1126-01
	214-1126-02			2						80009	214-1126-02
-32	214-1752-00			8						80009	214-1752-00
-33	401-0369-00			2						80009	401-0369-00
-34	311-0325-00			2						12697	381-CM39666
-35	105-0934-00			2						80009	105-0934-00
-36	105-0935-00			2						80009	105-0935-00
-37	343-1020-00			2						80009	343-1020-00
-38	211-0325-00			4						01536	OBD
-39	361-1193-00			2						80009	361-1193-00
-40	131-1758-11			2						80009	131-1758-11
	131-1758-12			2						80009	131-1758-12
-41	131-0787-00			2						22526	47359
-42	131-0608-00			11						22526	47357

## Replaceable Mechanical Parts—2235 Service

Fig. & Index No.	Tektronix Part No.	Serial/Model No.		Qty						Name & Description	Mfr Code	Mfr Part Number
		Eff	Dscont		1	2	3	4	5			
3-43	670-7613-00			1						.CKT BOARD ASSY:TIMING (SEE A4 REPL) .....(ATTACHING PARTS).....	80009	670-7613-00
-44	211-0325-00			3						.SCR,ASSEM WSHR:4-40 X 0.25.PNH,TORX DRIVE .....(END ATTACHING PARTS).....	01536	OBD
-45	131-0608-00			18						..TERMINAL,PIN:0.365 L X 0.025 PH BRZ GOLD	22526	47357
-46	131-0787-00			4						..CONTACT,ELEC:0.64 INCH LONG	22526	47359
-47	337-2944-00			1						.SHIELD,ELEC:SW BOARDS,BOTTOM	80009	337-2944-00
-48	210-0406-00			2						.NUT,PLAIN,HEX.:4-40 X 0.188 INCH,BRS	73743	12161-50
-49	129-0906-00			2						.SPACER,POST:0.685 L W/4-40 INT & EXT TH	80009	129-0906-00

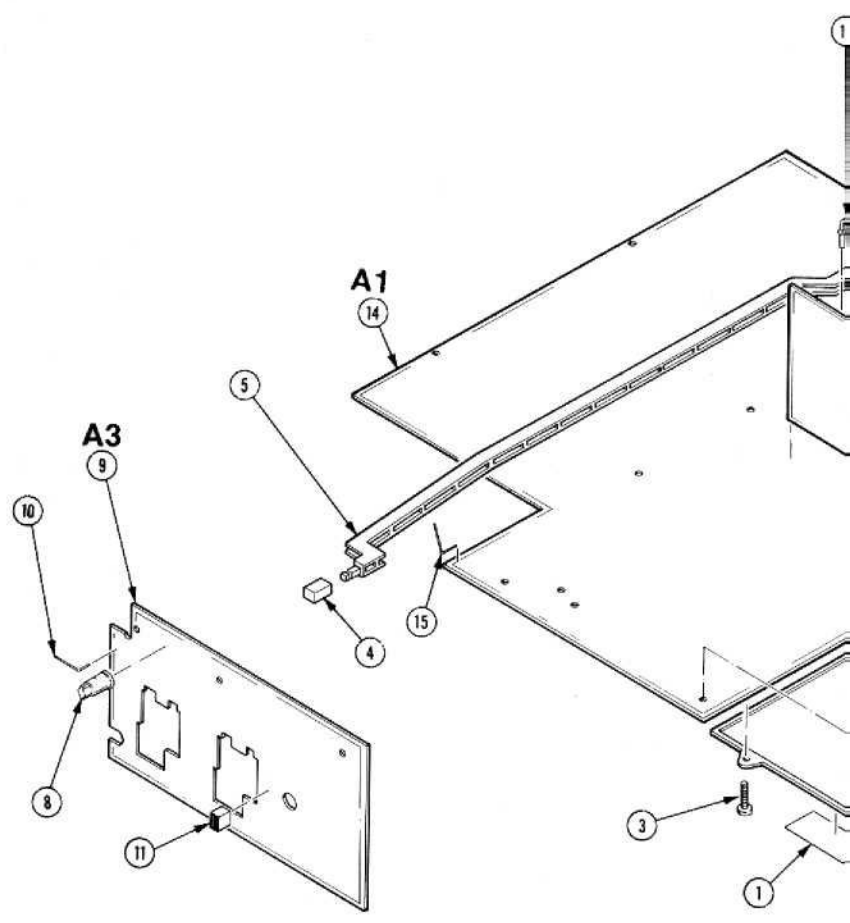
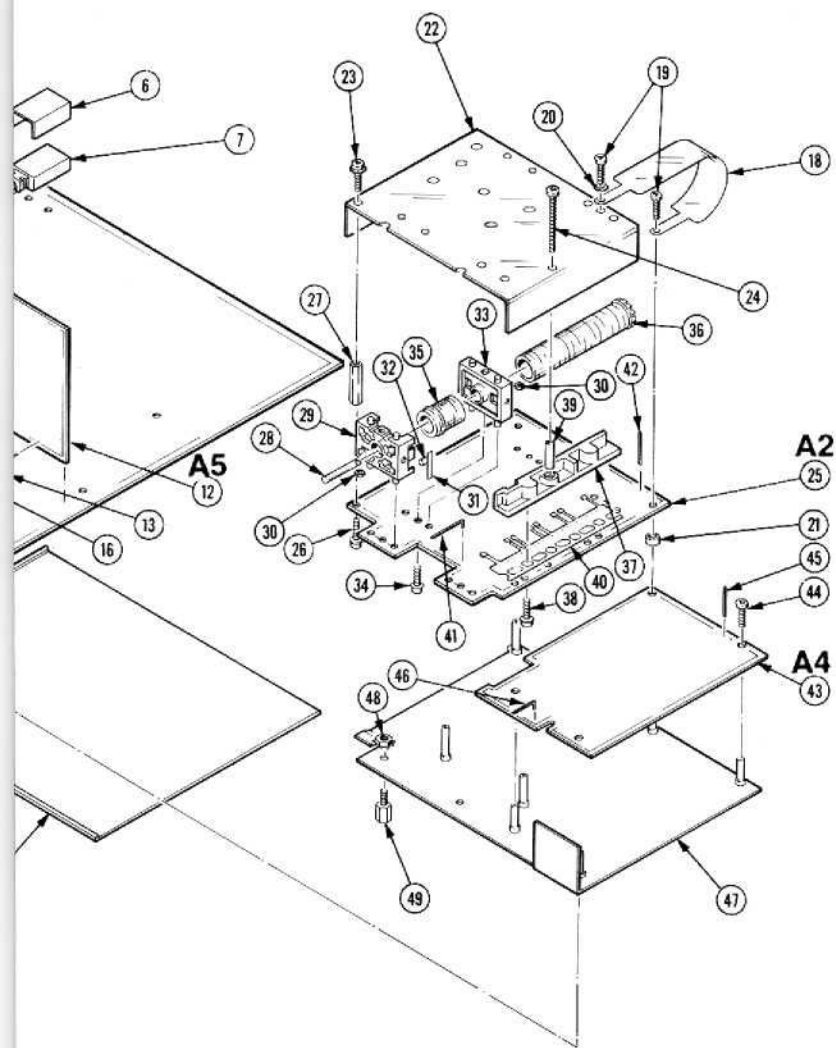

FIG. 3 ATTENUATOR ASSY. & BOTTOM



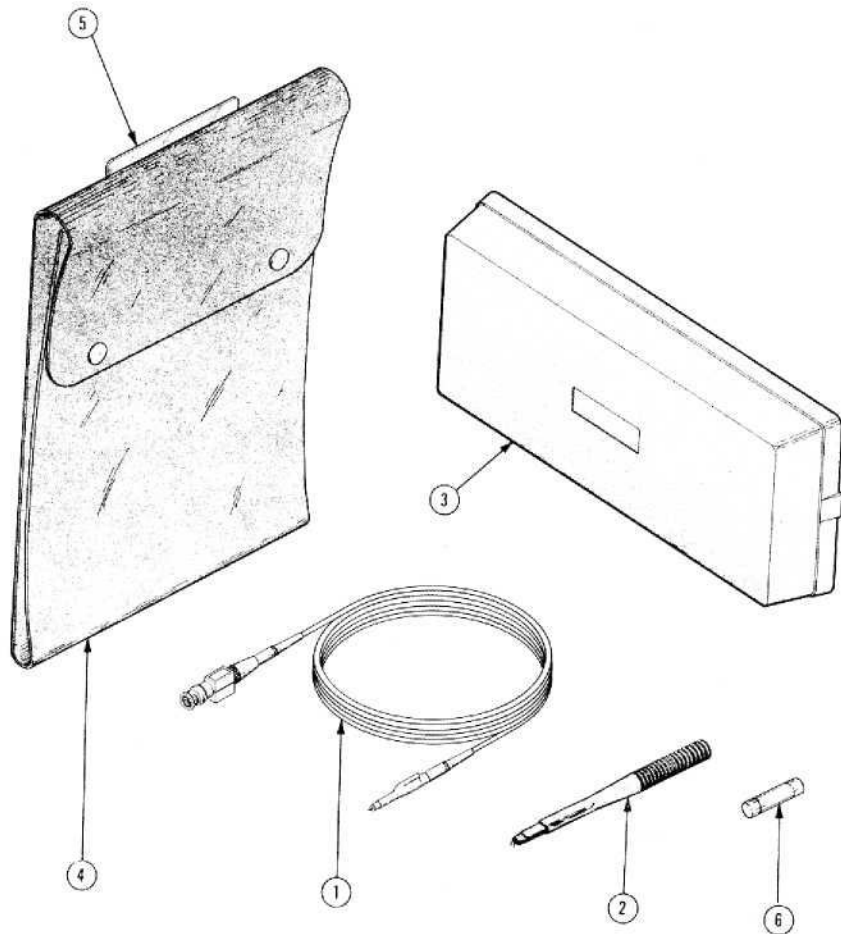

Fig. & Index No.	Tektronix Part No.	Serial/Model No. Eff	Dscont	Qty	1	2	3	4	5	Name & Description	Mfr Code	Mfr Part Number
STANDARD ACCESSORIES												
-1	010-6122-01			2						PROBE, VOLTAGE: P6122, 1.5 METER, 10X W/ACCESS	80009	010-6122-01
	161-0104-00			1						CABLE ASSY, PWR, : 3 WIRE, 98.0" LONG	16428	KH8352
	070-4206-00			-						(SEE FIG. 2 RMPL)		
	070-4207-00			1						MANUAL, TECH: SERVICE, 2235 OSCILLOSCOPE	80009	070-4206-00
				1						MANUAL, TECH: OPERATORS, 2235 OSCILLOSCOPE	80009	070-4207-00
OPTIONAL ACCESSORIES												
-2	013-0191-00			2						TIP, PROBE: W/ACTUATOR	80009	013-0191-00
	020-0672-00			1						ACCESSORY KIT:	80009	020-0672-00
-3	200-2520-00			1						. COVER, SCOPE: FRONT	80009	200-2520-00
	016-0677-00			1						. POUCH, ACCESSORY:	80009	016-0677-00
-4	016-0535-01			1						. . . POUCH, ACCESSORY:	80009	016-0535-01
-5	386-4647-01			1						. . . PLATE, MOUNTING: BACK, ALUM	80009	386-4647-01
-6	159-0019-00			1						. . . FUSE CARTRIDGE: 3AG, 1A, 250V, SLO-BLO	71400	MDL1
				1						C5C OPTION 4 CAMERA		
				-						(SEE MANUAL 070-2824-XX)		
				1						200C OR 200D SCOPEMOBILES		
				-						(SEE DATA SHEETS 062-1538-00 OR 062-6644-00)		
	016-0466-00			1						ADAPTER, RACK:	80009	016-0466-00
				-						(SEE MANUAL 070-4186-XX)		

## **MANUAL CHANGE INFORMATION**

At Tektronix, we continually strive to keep up with latest electronic developments by adding circuit and component improvements to our instruments as soon as they are developed and tested.

Sometimes, due to printing and shipping requirements, we can't get these changes immediately into printed manuals. Hence, your manual may contain new change information on following pages.

A single change may affect several sections. Since the change information sheets are carried in the manual until all changes are permanently entered, some duplication may occur. If no such change pages appear following this page, your manual is correct as printed.

Date: 2-16-83

Change Reference: M50226

Product: 2213, 2215, 2235, 2236

Manual Part No.: See Below

DESCRIPTION

2213 (070-3827-00)-B029390

2215 (070-3826-00)-B031640

2235 (070-4206-00)-B010380

2236 (070-4204-00)-B010550

REPLACEABLE ELECTRICAL PARTS LIST CHANGES

2213, 2215

CHANGE TO:

A10T940      120-1348-01      XFMR,PWR,SDN&SU: HIGH VOLTAGE

2235, 2236

CHANGE TO:

A1T948      120-1348-01      XFMR,PWR,SDN&SU: HIGH VOLTAGE

**DESCRIPTION**

PG 46

**TEXT CHANGES**

(EFFECTIVE ALL SERIAL NUMBERS)

Page 5-5 STEP 4 Adjust Astigmatism (R874).

Change part b. to read as follows:

- b. Connect the leveled sine-wave generator output via a 50-Ω cable and a 50-Ω termination to the CH 1 OR X input connector.

**REPLACEABLE ELECTRICAL PARTS LIST CHANGES**

(SEE BELOW FOR EFFECTIVE SERIAL NUMBERS)

**CHANGE TO:**

A1C785	ALL SN's	281-0214-00	CAP,VAR,CER DI: 0.5-3PF,400V	PC9
A1R122	B010450	315-0820-00	RES,FXD,CMPSN: 82 OHM,5%,0.25W	PC16
A1R172	B010450	315-0820-00	RES,FXD,CMPSN: 82 OHM,5%,0.25W	PC16
A1R317	B010450	321-0218-00	RES,FXD,CMPSN: 1.82K OHM,1%,0.125W	PC16
A1R318	B010450	321-0193-00	RES,FXD,CMPSN: 1K OHM,1%,0.125W	PC16
A1R319	B010450	321-0212-00	RES,FXD,CMPSN: 1.58K OHM,1%,0.125W	PC16
A1R322	B010450	321-0238-00	RES,FXD,CMPSN: 2.94K OHM,1%,0.125W	PC16
A1R342	B010450	321-0218-00	RES,FXD,CMPSN: 1.82K OHM,1%,0.125W	PC16
A1R343	B010450	321-0193-00	RES,FXD,CMPSN: 1K OHM,1%,0.125W	PC16
A1R344	B010450	321-0212-00	RES,FXD,CMPSN: 1.58K OHM,1%,0.125W	PC16
A1R347	B010450	321-0238-00	RES,FXD,CMPSN: 2.94K OHM,1%,0.125W	PC16
A1R352	B010450	321-0274-00	RES,FXD,CMPSN: 6.98K OHM,1%,0.125W	PC16
A1R353	B010450	321-0274-00	RES,FXD,CMPSN: 6.98K OHM,1%,0.125W	PC16

**ADD:**

A1C500	ALL SN's	281-0893-00	CAP,FXD,CER DI: 4.7PF, ± 0.5PF,100V	PC11
A1R354	B010450	315-0272-00	RES,FXD,CMPSN: 2.7K OHM,5%,0.25W	PC16
A1R500	ALL SN's	315-0101-00	RES,FXD,CMPSN: 100 OHM,5%,0.25W	PC11
A3R201	ALL SN's	315-0200-00	RES,FXD,CMPSN: 20 OHM,5%,0.25W	PC13
A3R401	ALL SN's	315-0200-00	RES,FXD,CMPSN: 20 OHM,5%,0.25W	PC10

**CHASSIS PARTS LIST CHANGES**

(SEE BELOW FOR EFFECTIVE SERIAL NUMBERS)

**ADD:**

R909	B010395	315-0390-00	RES,FXD,CMPSN: 39 OHM,5%,0.25W	PC17
------	---------	-------------	--------------------------------	------

**DIAGRAM CHANGES**

(SEE BELOW FOR EFFECTIVE SERIAL NUMBERS)

DIAGRAM  VERTICAL PREAMP AND OUTPUT AMPL

Change R122 (location 3E) and R172 (location 9E) to 82 ohm resistors B010450 PC16

Disconnect pin 1 from ground on S200 (location 6A) and S226 (location 3K).  
These two pins are then connected together and R201 (20Ω) is added from this connection to ground. ALL SN's PC13

DESCRIPTION

DIAGRAM CHANGES (cont)

(SEE BELOW FOR EFFECTIVE SERIAL NUMBERS)

DIAGRAM 3 TRIGGERING

- Change R352 (location 2K) and R353 (location 2K) to 6.98K ohm resistors. B010450 PC16
- Change R322 (location 3J) and R347 (location 6J) to 2.94K ohm resistors. B010450 PC16
- Change R319 (location 2H) and R344 (location 5J) to 1.58K ohm resistors. B010450 PC16
- Change R318 (location 1G) and R343 (location 3G) to 1.0K ohm resistors. B010450 PC16
- Change R317 (location 1F) and R342 (location 3F) to 1.82K ohm resistors. B010450 PC16
- Add R354 (2.7K ohm) from the junction of pins 9 and 14 of U350 (location approximately 3K) to  $-8.6 V_{C1}$ . B010450 PC16

DIAGRAM 4 A SWEEP GENERATOR & LOGIC

- Disconnect pin 4 from ground on S401B (location 8A) and add R401 (20 ohm) from pin 4 to ground. ALL SN's PC10
- Add C500 (4.7pF) & R500 (100Ω) to U502 as shown below. ALL SN's PC20

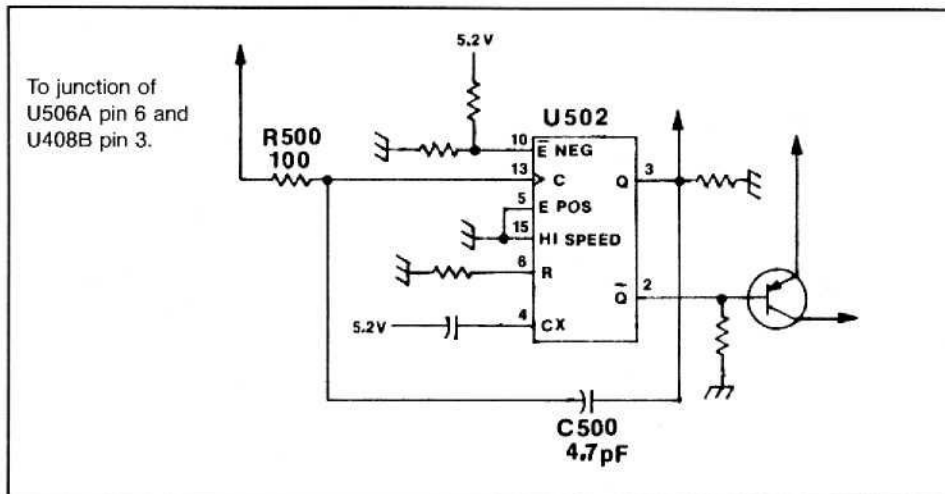

DIAGRAM 7 POWER SUPPLY, Z-AXIS AND CRT

- Add R909 (39 ohm) at location 8H as shown below. B010395 PC17

