

INSTRUCTION MANUAL

GONSET
Super-ciever

MODEL 3041

801 S. MAIN ST.



BURBANK, CALIF.

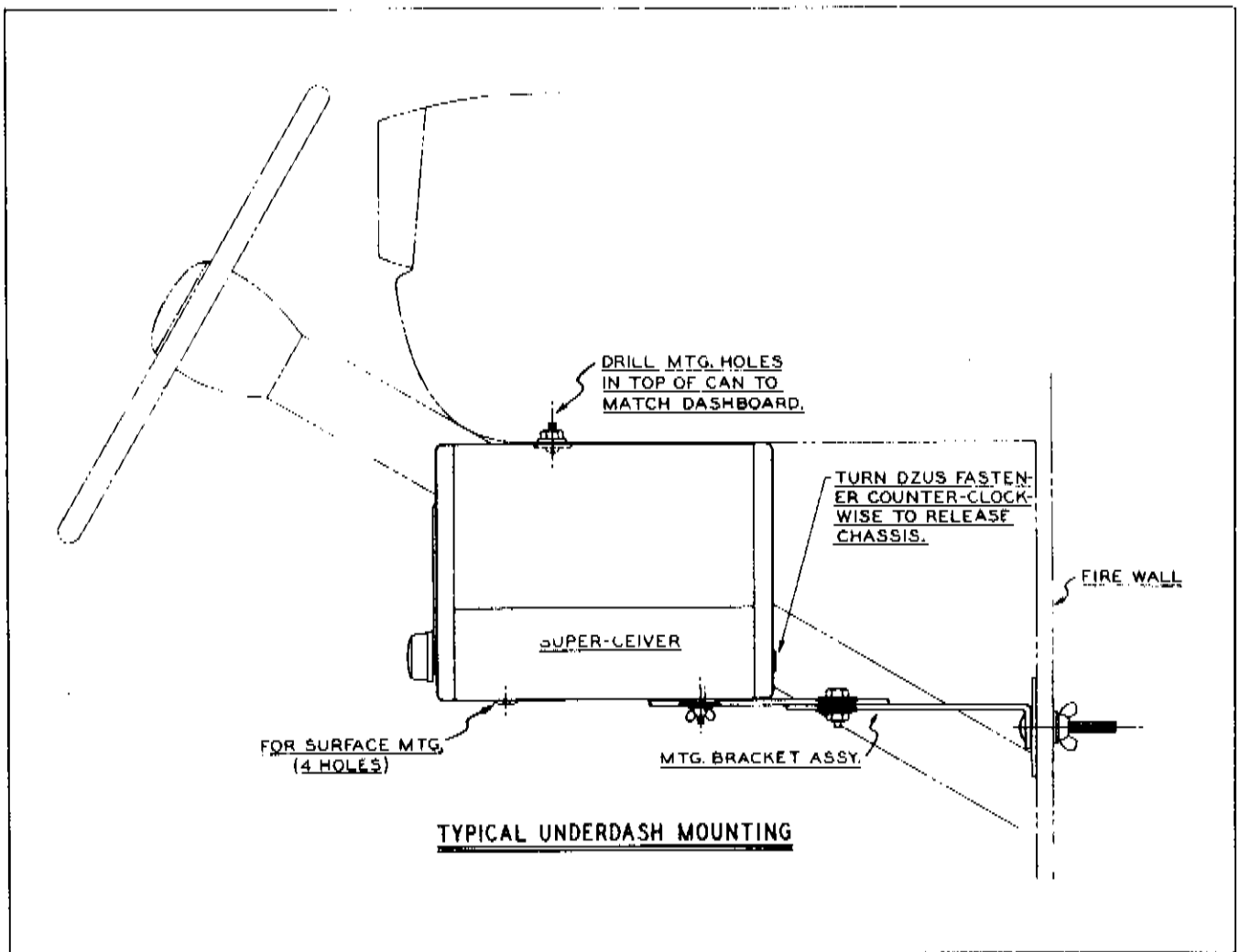

transmit, but also saves the vibrator drain during transmit periods. If the gray lead must be extended to reach the relay, use heavy gauge wire to avoid voltage drop.

With a typical lag in transmitter plate voltage build up, as occurs with a dynamotor or with a vibrator pack having a large input condenser, no feedback "yoop" will occur when switching from receive to transmit. To avoid a yoop when switching from transmit to receive, particularly with a dynamotor, it may be necessary to employ a "dumping resistor" on the T/R relay. This may consist of a 220 ohm 2 watt resistor so connected that it shorts the transmitter high voltage to ground (or else to the hot "A" lead) when the relay is in the receive position.

To permit spotting the transmitter v-f-o or crystal oscillator on the receiver dial, it is necessary to apply battery voltage to the Super-Ceiver vibrator when the transmitter high voltage is on. This is accomplished by means of the mute disabling switch on the rear of the control unit. To prevent the Super-Ceiver from being muted when the transmitter is thrown on, simply throw the switch lever to the right. This switch lever is the one which protrudes below the control unit (on the rear). For mute operation via the T/R relay, the switch lever is left thrown to the left. When no transmitter is employed, both the brown and gray pigtailed should be connected to the battery bus in order to minimize

voltage drop through the wires.

OPERATION

With all cables connected and the receiver and converter turned on, and the Super-Ceiver chassis slid forward out of its case, turn the a-f gain control full up and the r-f gain control well down to give a low level of background noise. Then, with a wedge or blade-tipped plastic alignment tool, adjust the two trimmers on the top of the double tuned r-f input transformer for maximum gain as evidenced by maximum noise. (This is the square shield can closest to the left rear corner.) With a Super-Six or Tri-Band converter, this adjustment should be made after first screwing the output trimmer on the converter nearly all the way out (or removing the screw altogether). With other makes of converters, follow the manufacturer's recommendation regarding any output trimmer adjustments.

The Super-Ceiver is now ready for use and may be replaced in its cabinet. Because of the number of controls provided for maximum versatility and performance, it will take a day or so to become familiar with all the controls and their functioning. However, a few tips will speed the familiarization.

There is no on-off switch on the squelch. It is

CONVERTER CONNECTIONS

(Attach wires to plug PL3)

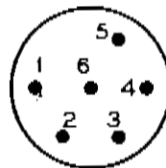

PLUG-PL3
REAR VIEW

- ① HEATER
- ② AVC
- ③ RF GAIN (CATHODE)
- ④ B⁺105V. REGULATED
10MA. MAX.
- ⑤ B⁺180V. 25 MA. MAX.
- ⑥ GND.

INTER-CONNECTING
CABLE-PL1

CONVERTER SOCKET -SOC3

MUTE BYPASS
SWITCH
(SEE INSTRUCTIONS)

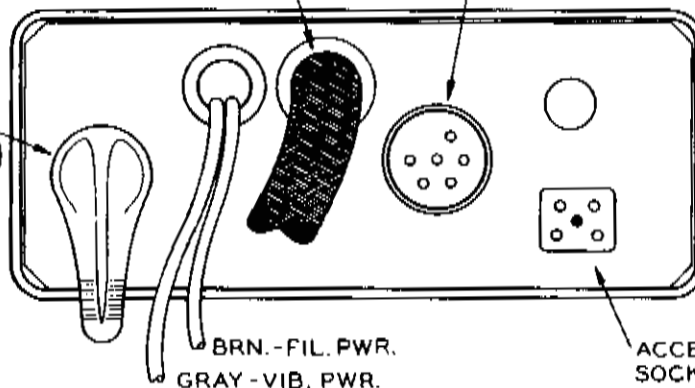

BRN.-FIL. PWR.
GRAY-VIB. PWR.

ACCESSORY
SOCKET -SOC4



PL4
REAR VIEW

- ① AVC (DO NOT LOAD)
- ② GND.
- ③ B⁺180V. 5MA. MAX. CONTIN-
UOUS.
- ④ HEATER VOLTAGE

disabled simply by turning the threshold control full to the right, but not so far as to click the switch.

The b-f-o is turned on by turning the squelch control fully clockwise until the switch clicks. This turns on the b-f-o, disables the squelch, and disables the a-v-o.

After a few days experience with operation of the squelch, one will learn under what conditions it can be used to advantage. The widely varying background noise level existing on some bands in some localities will make operation of the squelch impractical except when receiving very strong signals, permitting the threshold control to be backed way off.

If turning the squelch control fully counter-clockwise does not squelch the receiver (due to high background noise level), then the r-f gain control should be backed off enough to squelch the receiver.

The best ratio of r-f gain to a-f gain to use on phone signals will depend upon the converter gain, ambient noise level, and other factors. Running the r-f gain at too low a setting will reduce the a-v-o action. Too high a setting will cause strong ambient noise to "load up" the a-v-o, causing trouble on weak signals. The separate controls permit the optimum adjustment to be made under any particular receiving conditions.

When receiving c-w or single sideband signals,

the a-f gain control should be run full or nearly full on, and the r-f gain control used to adjust volume. This will reduce blocking by strong signals, and provide optimum b-f-o injection. On 40 and 75 meters it will be possible to receive single sideband signals while under way with most converters if the h-f oscillator plate voltage is voltage regulated. On the higher frequency bands, however, changes in heater voltage will cause sufficient oscillator shift to preclude satisfactory s.s.b. reception except when parked.

On both c-w and s.s.b. the b-f-o pitch control on the main cabinet should be adjusted for the desired amount of "offset." When using the b-f-o simply to aid in "spotting" the transmitter frequency or locating weak phone carriers, the pitch control should be adjusted to give the lowest pitch to the background hiss when no station is tuned in. This places the b-f-o frequency at the exact center of the i-f pass band.

Ordinarily the noise clipper will be left turned on at all times except when receiving c-w or s.s.b. signals, or as an aid in peaking up trimmers on background noise.

It will be noted that when a conventional phone signal is tuned in "on the nose," all modulation frequencies above about 2500 cycles are highly attenuated. This is normal and is caused by the clipping of the sidebands by the narrow pass band of the i-f

6 VOLT - 12 VOLT CHANGEOVER CONNECTIONS

CONNECTIONS SHOWN ARE FOR 6 VOLT OPERATION.
FOR 12 VOLT CONVERSION, CHANGE WIRES AS DESCRIBED IN TEXT.

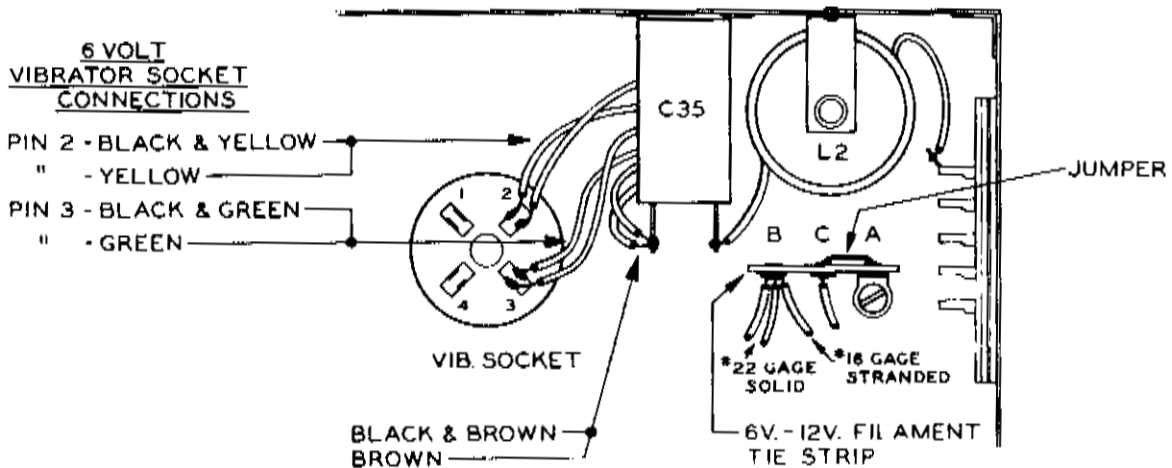

system. This characteristic is typical of any receiver having a sharp i-f system.

Should the occasion arise for aligning or checking the alignment of the i-f system, a Walsco type 2526 alignment tool (or equivalent) is required. The slugs for both primary and secondary windings of each i-f-t are reached from the top of the can. The specified alignment tool is designed to permit insertion through the keyed hole in the top slug to reach the bottom slug. To adjust the lower slug, the tool is passed through the top slug and down until it engages with the keyed hole in the bottom slug.

ACCESSORY CONNECTOR

A separate connector socket, SOC-4, is provided on the back of the control unit for connection of a vacuum tube type "S-meter" or for other purposes. As shown on the pictorial schematic, plate voltage, heater voltage, ground, and a-v-c voltage are accessible by making connections to PL-4 and plugging into SOC-4. The maximum permitted continuous B drain is 5 ma., which is adequate for an S-meter of the vacuum tube type. The B plus connection also may be used via a "spotting switch" to permit turning on the transmitter oscillator for frequency checking purposes without need for actuating the main transmitter power supply via the T/R relay. For this application, as much as 25 ma. may be drawn from pin 3 for

periods not exceeding a few seconds.

6 TO 12 VOLT CONVERSION

While the Super-Converter is available for 12 volt operation, provision is made for quick conversion from one to the other should the need ever arise. Referring to the accompanying illustration of the referenced wires and tie points, a 6 volt model is converted for 12 volt operation as follows: (For conversion from 12 to 6 volts, simply reverse the procedure.)

1. Remove solid jumper wire from terminal C on heater tie strip to ground.
2. Unsolder brown stranded wire from terminal B on heater tie strip and solder to terminal C.
3. Unsolder from hash condenser C-35 the two leads that come from power transformer T-8, tape the ends individually, and push them out of the way under C-35 and L-2.
4. Unsolder the four primary leads from the vibrator socket (connected in pairs) and resolder the black-yellow lead to vibrator socket pin #2 and the green lead to pin #3. Solder the black-green lead and the yellow lead to the terminal on C-35 from which wires were previously removed.

Readings of $\pm 10\%$ are normal

TUBE SOCKET VOLTAGE CHART

Tube	Pin Numbers								
	1	2	3	4	5	6	7	8	9
V1 (6BA7)	78	-17	-	0 - 0	± 6 - ± 6	-	-1.3	-	158
V2 (6BJ6)	-1	1.25	0 - 0	± 6 - ± 6	165	55	-	-	-
V3 (6BJ6)	-	1.25	0 - ± 12	± 6 - ± 6	165	55	-	-	-
V4 (6T8)	-1	-0.85	-0.8	0 - 0	± 6 - ± 6	-1.5	-	-1	+24* -0.1
V5 (6AQ5)	-	10.5	± 6 - ± 6	0 - ± 12	228	170	-	-	-
V6 (12AT7)	(b-f-on) 54	-3	-	0 - ± 12	0 - ± 12	160* 62	14* -0.8	107* 0	± 6 ± 6
V7 (OB2)	107	-	-	-	107	-	-	-	-
V8 (6X4) (12X4)	215 AC	107	± 6 - ± 12	0 - 0	-	215 AC	240	-	-

NOTE: All readings taken with RCA Volt-Ohmst, are plus DC unless otherwise indicated, and are for 6.3 volts input to control head with 6 volt connection. All voltages will run slightly higher with 12.6 volt operation. Test conditions are no r-f input, clipper on, RF gain control full on, squelch control full clockwise and BFO off unless otherwise indicated.

* Squelch control full counterclockwise

5. Substitute a type 12X4 for the 6X4 rectifier tube, a Mallory G-659 vibrator for the type 659, and 5 ampere fuses for the 10 ampere primary fuses.

Super-Six converter is available in a 12 volt model. Instructions for converting a 6 volt model to 12 volts will be furnished on request.

NOTE: Before plugging in the converter make sure it is wired for 12 volt heater supply. The

SOCKET INPUT
(SEE NOTE 5)

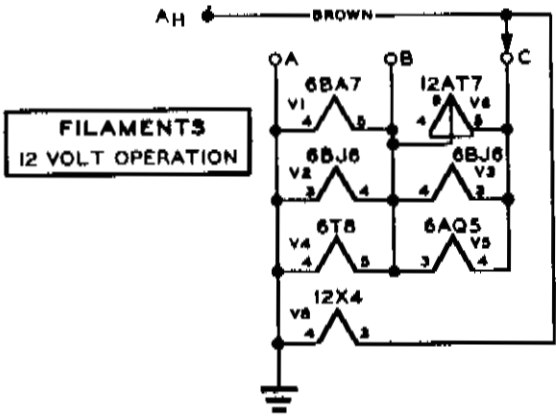
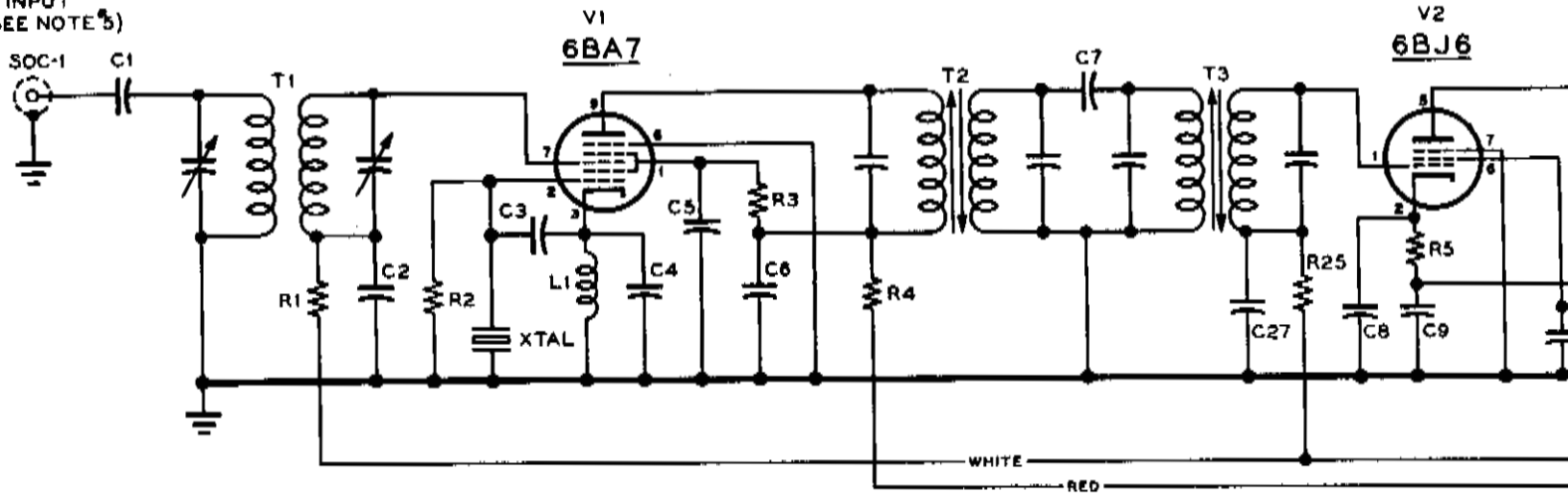

NOTE:

1. BFO SWITCH OPERATES AT EXTREME CLOCKWISE END OF SQUELCH CONTROL.
2. SOC3-CONVERTER SOCKET
3. SOC4-AUXILIARY TUNER SOCKET
4. INTERMEDIATE FREQUENCY-265 KC ± 1 KC
5. $XTAL = F_{SIG} + 265 KC$ WHERE F_{SIG} IS INPUT FREQUENCY OF SUPER-CEIVER.
6. REMOVE JUMPER TO SILENCE ENCLOSED SPEAKER WHEN USING REMOTE SPEAKER.
7. USE WALSCO #2526 OR EQUAL, TO ALIGN IF TRANSFORMERS.

POWER SUPPLY
12 VOLT OPERATION

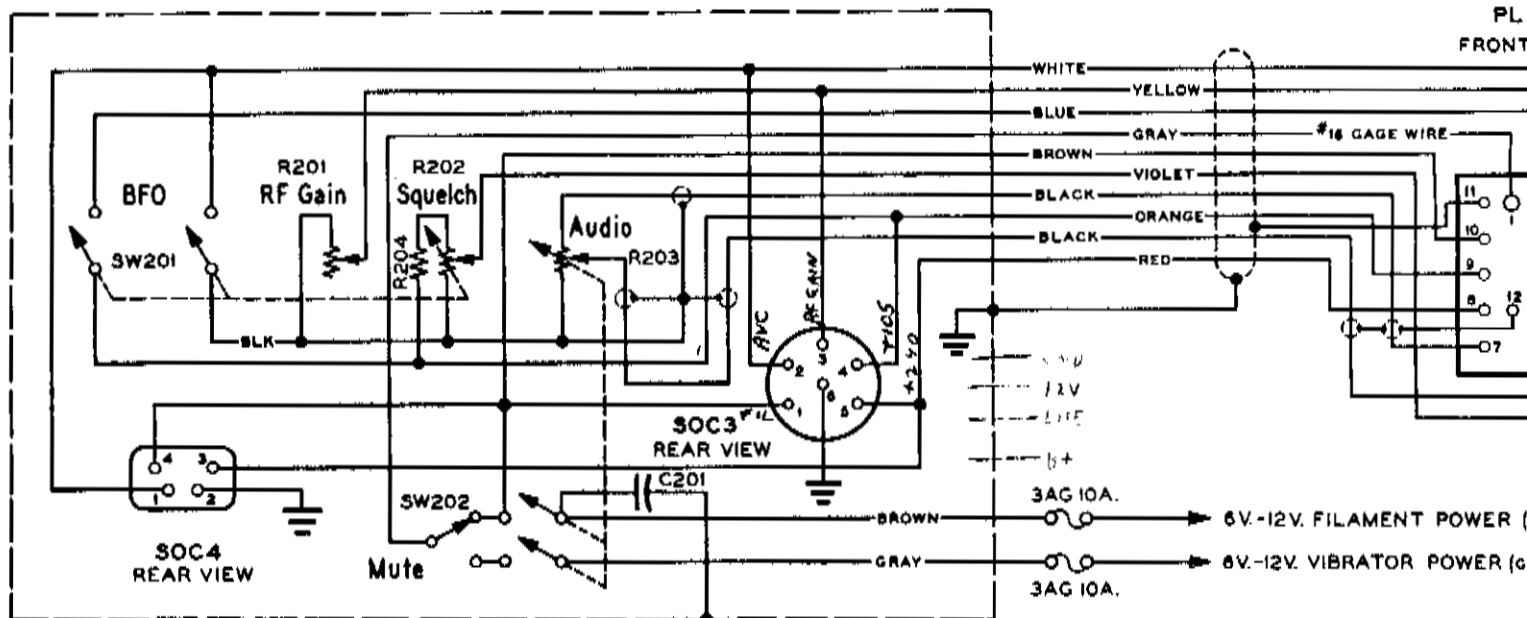
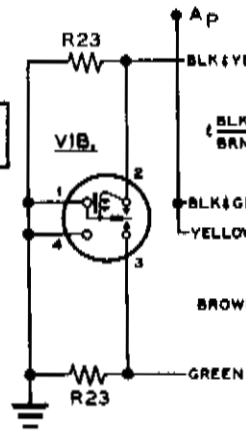

PRODUCTION CHANGES:
R7 changed to 2700 ohms 0.5 watt. R8 moved from bottom of R10 to top. R9 changed to 470K.

C1 - 30 MMF	C13 - 50 MMF	C25 - .01 MFD GMV CERAMIC	C37 - .002 M
C2 - .01 MFD GMV CERAMIC	C14 - 50 MMF	C26 - 5 MMF	C38 - 470 M
C3 - 30 MMF	C15 - .01 MFD GMV CERAMIC	C27 - .01 MFD GMV CERAMIC	C39 - .01 M
C4 - 500 MMF	C16 - .001 MFD GMV CERAMIC	C28 - .001 MFD GMV CERAMIC	R1 - 1.2 M
C5 - .01 MFD GMV CERAMIC	C17 - 25 MFD 25V. ELECTROLYTIC	C29 - 4 MFD 150V. ELECTROLYTIC	R2 - 100M
C6 - .01 MFD GMV CERAMIC	C18 - .0047 MFD. 1600V. PAPER	C30 - .001 MFD GMV CERAMIC	R3 - 15K
C7 - 2 MMF	C19 - .01 MFD GMV CERAMIC	C31 - .01 MFD GMV CERAMIC	R4 - 2.7K
C8 - .01 MFD GMV CERAMIC	C20 - .01 MFD GMV CERAMIC	C32 - .01 MFD GMV CERAMIC	R5 - 470
C9 - .25 MFD 200V.	C21 - 20 MFD 350V ELECTROLYTIC	C33 - 12 MFD 450V. ELECTROLYTIC	R6 - 2.7K
C10 - .1 MFD 800V.	C22 - 270 MMF	C34 - .0065 MFD 1600V.	R7 - 2.7K
C11 - .01 MFD GMV CERAMIC	C23 - 1000 MMF	C35 - .5 MFD 120V.	R8 - 2.7K
C12 - .01 MFD GMV CERAMIC	C24 - 25 MMF	C36 - .01 MFD GMV CERAMIC	R9 - 270K
			R10 - 1.2 M

022299

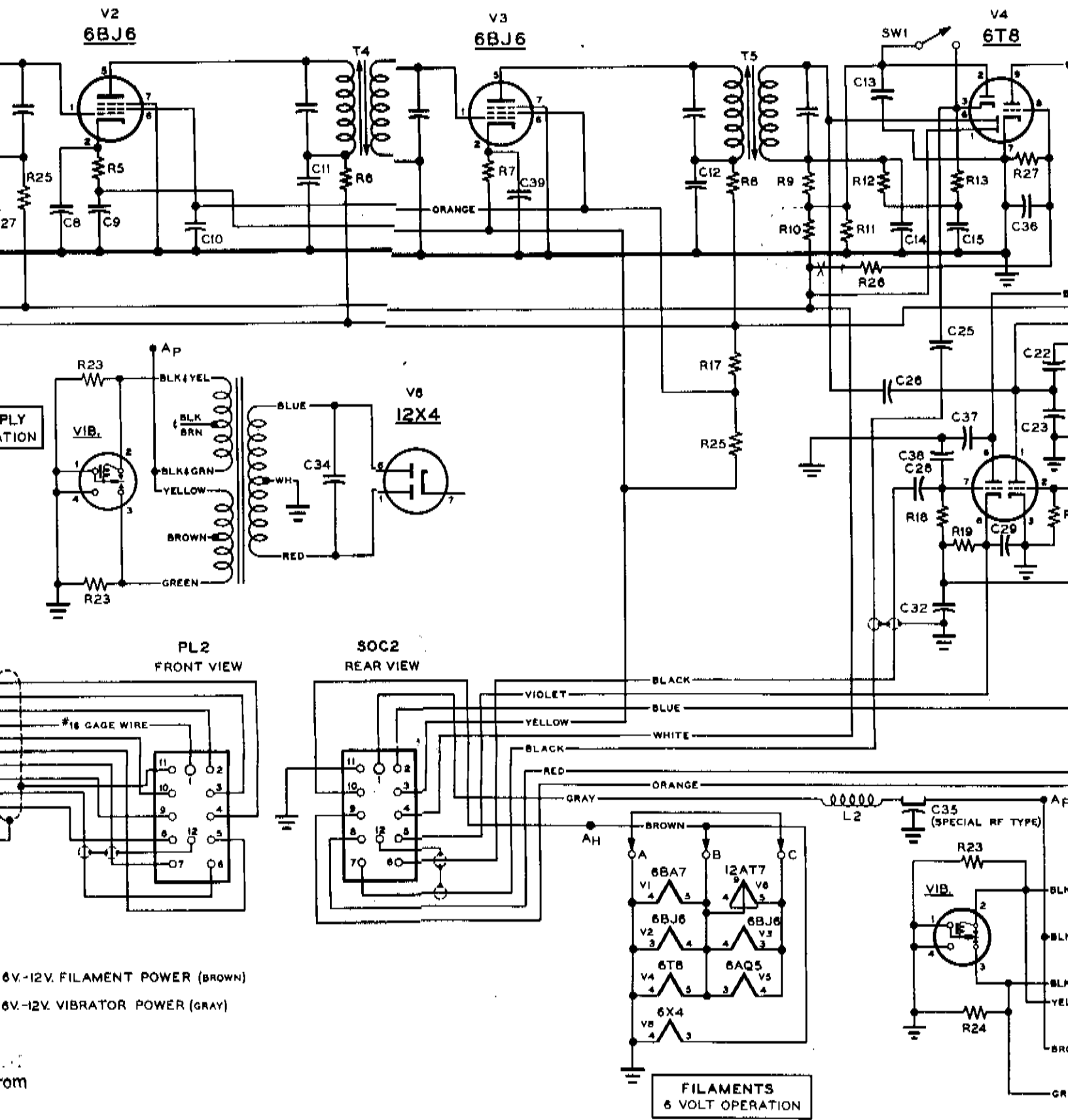

6V.-12V. FILAMENT POWER (BROWN)
 6V.-12V. VIBRATOR POWER (GRAY)

from

- C37-.002 MFD GMV CERAMIC
- C38-470 MMF
- C39-.01 MFD GMV CERAMIC
- R1 - 1.2 MEG $\frac{1}{2}$ W.
- R2 - 100K $\frac{1}{2}$ W.
- R3 - 15K 1 W.
- R4 - 2.7K $\frac{1}{2}$ W.
- R5 - 470 OHM $\frac{1}{2}$ W.
- R6 - 2.7K $\frac{1}{2}$ W.
- R7 - 470 OHM $\frac{1}{2}$ W.
- R8 - 2.7K $\frac{1}{2}$ W.
- R9 - 270K $\frac{1}{2}$ W.
- R10 - 1.2 MEG $\frac{1}{2}$ W.

- R11 - 270K $\frac{1}{2}$ W.
- R12 - 1.2 MEG $\frac{1}{2}$ W.
- R13 - 1.2 MEG $\frac{1}{2}$ W.
- R14 - 100K $\frac{1}{2}$ W.
- R15 - 470K $\frac{1}{2}$ W.
- R16 - 470 OHM 1 W.
- R17 - 39K $\frac{1}{2}$ W.
- R18 - 0.2 MEG $\frac{1}{2}$ W.
- R19 - 1.2 MEG $\frac{1}{2}$ W.
- R20 - 47K $\frac{1}{2}$ W.
- R21 - 47K 1 W.
- R22 - 3.3K 5W.-W.W.

- R23-150 OHM 1W.
- R24-150 OHM 1W.
- R25-27K $\frac{1}{2}$ W.
- R201-10K POT R.F. TAPER
- R202-50K POT LINEAR TAPER - W/SPECIAL SW.
- R203-250K POT AUDIO TAPER
- R204-1K $\frac{1}{2}$ W.
- L1 - MIXER CHOKE - 50 MH
- L2 - VIB. FILTER CHOKE - MOTOROLA #24A600592
- L51 - 5" SPEAKER - 620 OHM FIELD.
- SOC1-ANTENNA INPUT - CINCH #2611

- R26-2.7 MEG $\frac{1}{2}$ W.
- R27-1.2 MEG $\frac{1}{2}$ W.

- SOC2-SOCKET - CINCH
- SOC3-SOCKET - 6 PIN
- SOC4-SOCKET - 4 PIN
- T1 - R.F. TRANSFORMER
- T6 - BFO TRANSFORMER
- T7 - OUTPUT TRANSFORMER
- T8 - POWER TRANSFORMER
- T2, T3, T4, T5 - I.F. TRANSFORMERS
- V6 - 6V. VIBRATOR
- V8 - 12V. VIBRATOR
- SW201 - PART OF R201

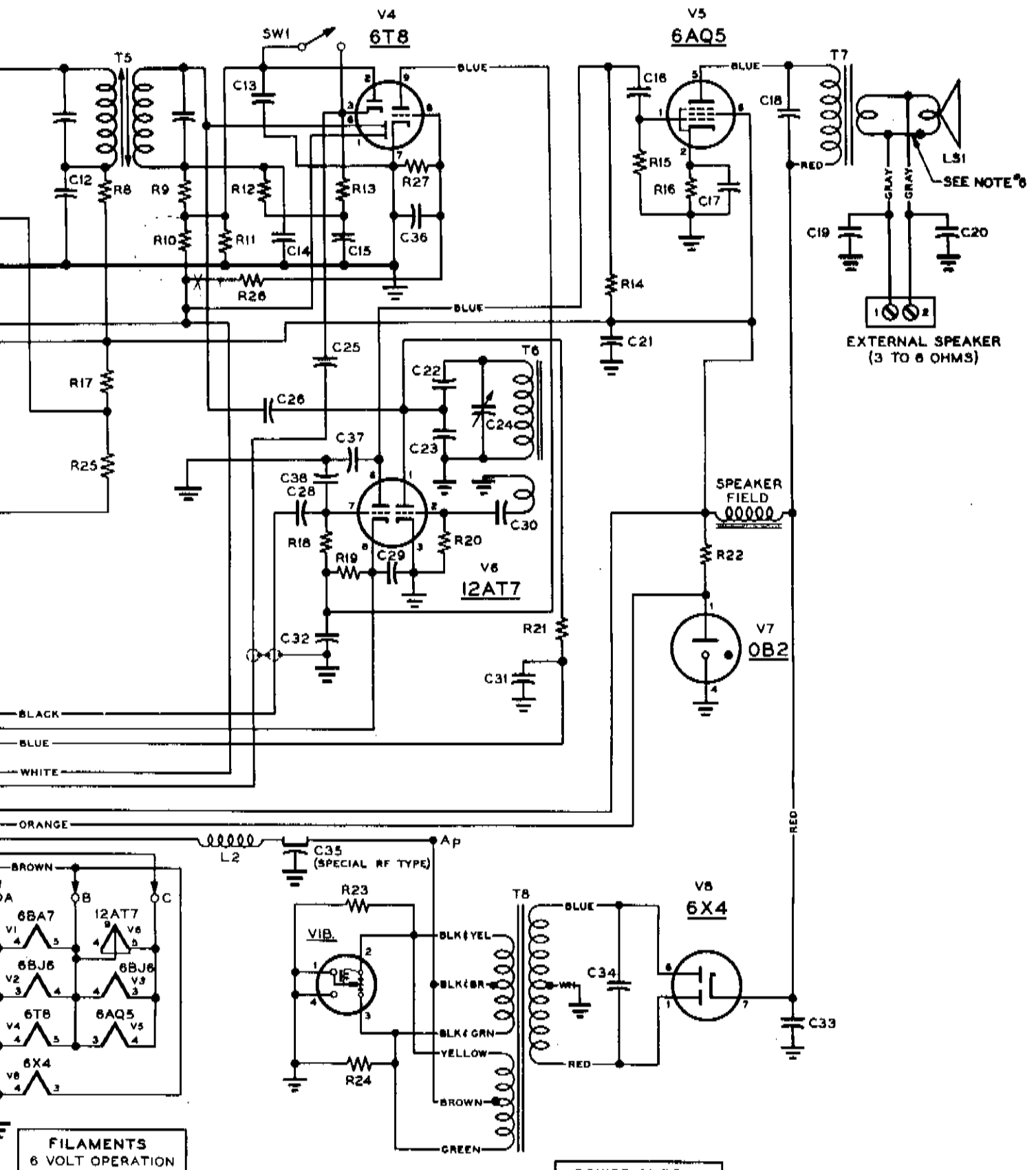

M 1W. R26 - 2.7 MEG $\frac{1}{2}$ W.
 M 1W. R27 - 1.2 MEG $\frac{1}{2}$ W.
 T R.F. TAPER
 OT LINEAR TAPER - W/SPECIAL SW.
 POT AUDIO TAPER
 W.
 CHOKE - 50 MH
 LTER CHOKE - MOTOROLA #24A800592
 AKER - 820 OHM FIELD.
 CINCH #12521
 NNA INPUT - CINCH #2611

SOC2 - SOCKET - CINCH #12523
 SOC3 - SOCKET - 6 PIN - CINCH #11916
 SOC4 - SOCKET - 4 PIN - CINCH #2675
 T1 - R.F. TRANSFORMER - MILLER #112-W1
 T6 - BFO TRANSFORMER - 265KC - RATEL #262BF
 T7 - OUTPUT TRANSFORMER - MERIT #A2931 OR #21V53
 T8 - POWER TRANSFORMER - SPECIAL
 T2, T3, T4, T5 - I.F. TRANSFORMER - 265KC - SPECIAL
 6V. VIBRATOR - MALLORY #859
 12V. VIBRATOR - MALLORY #G859
 SW201 - PART OF R202

SW1 & SW202 - SPDT SWITCH - OAK #23
 C201 - .25 MFD 100V. PAPER

**GONSET SUPER-CIEVER
MODEL 3041**



801 S. Main Street Burbank, California