

**OPERATOR'S AND ORGANIZATIONAL  
MAINTENANCE MANUAL  
FOR  
OSCILLOSCOPE  
AN/USM-488  
(NSN 6625-01-187-7847) (EIC: KNQ)**

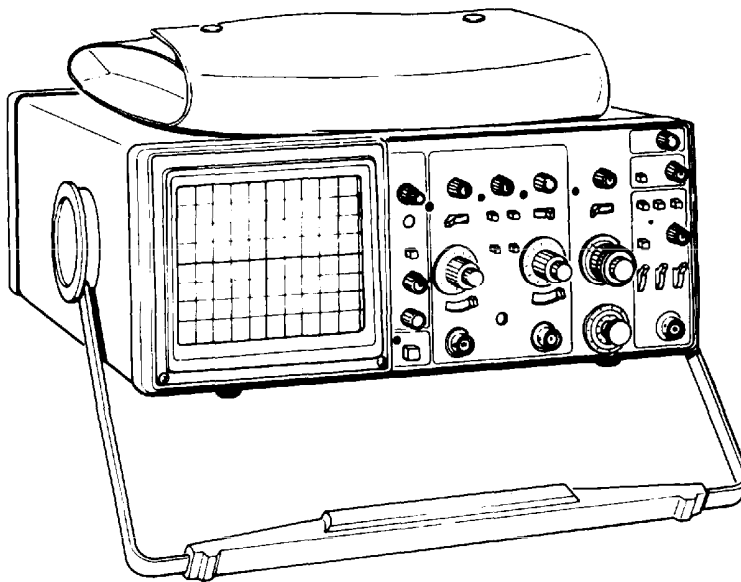

**EQUIPMENT  
DESCRIPTION  
PAGE 1-4**

**OPERATOR'S  
CONTROLS  
PAGE 2-2**

**OPERATOR  
PMCS  
PAGE 2-8**

**OPERATION  
PAGE 2-11**

**TROUBLESHOOTING  
PAGE 3-3**

**MAINTENANCE  
PROCEDURES  
PAGE 3-5**

**SUBJECT  
INDEX  
PAGE Index-1**

**WARNING** – This document contains technical data whose export is restricted by the Arms Export Control Act (Title 22, U. S. C., Sec 2751 et seq) or the Export Administration Act 1979, as amended, Title 50, U.S.C., App. 2401 et seq.. Violations of these export laws are subject to severe criminal penalties. Disseminate in accordance with provisions of DOD Directive 5230.25.

**DISTRIBUTION STATEMENT D** – Distribution authorized to Department of Defense and DoD contractors only to protect critical technical data on systems or hardware. This determination was made Oct 1986. Other requests shall be referred to: Program Manager, TMDE, ATTN: SFAE-CS-FT-T-TEMOD, Redstone Arsenal, AL 35898-5000.

**DESTRUCTION NOTICE** – Destroy by any method that will prevent disclosure of contents or reconstruction of the document.



**5**

**SAFETY STEPS TO FOLLOW IF SOMEONE IS THE VICTIM OF ELECTRICAL SHOCK:**

**1**

**DO NOT TRY TO PULL OR GRAB THE INDIVIDUAL.**

**2**

**IF POSSIBLE, TURN OFF THE ELECTRICAL POWER.**

**3**

**IF YOU CANNOT TURN OFF THE ELECTRICAL POWER, PULL, PUSH, OR LIFT THE PERSON TO SAFETY USING A DRY WOODEN POLE OR A DRY ROPE OR SOME OTHER INSULATING MATERIAL.**

**4**

**SEND FOR HELP AS SOON AS POSSIBLE.**

**5**

**AFTER THE INJURED PERSON IS FREE OF CONTACT WITH THE SOURCE OF ELECTRICAL SHOCK, MOVE THE PERSON A SHORT DISTANCE AWAY AND IMMEDIATELY START ARTIFICIAL RESUSCITATION.**

**WARNING**

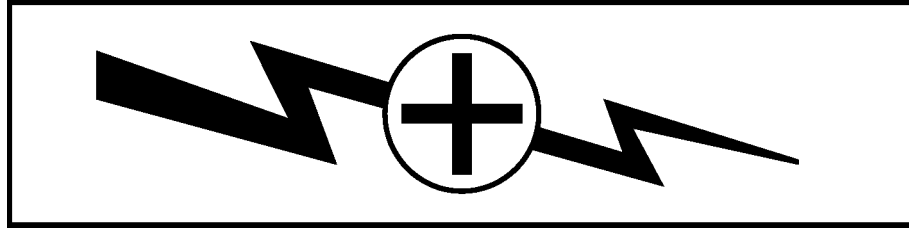

**HIGH VOLTAGE**

is used in the operation of this equipment

**DEATH ON CONTACT**

may result if personnel fail to observe safety precautions

Never work on electronic equipment unless there is another person nearby who is familiar with the operation and hazards of the equipment and who is competent in administering first aid. When technicians are aided by operators, they must warn them about dangerous areas.

A periodic review of safety precautions in TB 385-4, Safety Precautions for Maintenance of Electrical and Electronic Equipment, is recommended. When the equipment is operated with covers removed, DO NOT TOUCH exposed connections or components. MAKE CERTAIN you are not grounded when making connections or adjusting components inside the test instrument.

Be careful not to contact high-voltage connections of 115 volt ac input when installing or operating this equipment.

Whenever the nature of the operation permits, keep one hand away from the equipment to reduce the hazard of current flowing through the body.

**WARNING**

Do not be misled by the terms "LOW VOLTAGE." Potentials as low as 50 volts can cause death under certain conditions.

For First Aid, refer to FM 4-25.11.

CHANGE }  
No. 2 }

Headquarters  
Department of the Army  
Washington, D.C., 13 November 2006

**OPERATOR'S AND ORGANIZATIONAL MAINTENANCE MANUAL  
FOR  
OSCILLOSCOPE  
AN/USM-488  
(NSN 6625-01-187-7847) (EIC: KNQ)**

**HAZARDOUS MATERIAL INFORMATION** – This document has been reviewed for the presence of solvents containing hazardous materials as defined by the EPCRA 302 and 313 lists by the Engineering, Environment, and Logistics Oversight Office. As of the base document through Change 1, dated 15 September 1991, all references to solvents containing hazardous materials have been removed from this document by substitution with non-hazardous or less-hazardous materials where possible.

**OZONE DEPLETING CHEMICAL INFORMATION** – This document has been reviewed for the presence of Class I ozone depleting chemicals by the Engineering, Environment, and Logistics Oversight Office. As of the base document through Change 1, dated 15 September 1991, all references to Class I ozone depleting chemicals have been removed from this document by substitution with chemicals that do not cause atmospheric ozone depletion.

**WARNING** – This document contains technical data whose export is restricted by the Arms Export Control Act (Title 22, U. S. C., Sec 2751 et seq) or the Export Administration Act 1979, as amended, Title 50, U.S.C., App. 2401 et seq.. Violations of these export laws are subject to severe criminal penalties. Disseminate in accordance with provisions of DOD Directive 5230.25.

**DISTRIBUTION STATEMENT D** – Distribution authorized to Department of Defense and DoD contractors only to protect critical technical data on systems or hardware. This determination was made Oct 1986. Other requests shall be referred to: Program Manager, TMDE, ATTN: SFAE-CS-FT-T-TEMOD, Redstone Arsenal, AL 35898-5000.

**DESTRUCTION NOTICE** – Destroy by any method that will prevent disclosure of contents or reconstruction of the document.

TM 11-6625-3135-12, dated 1 October 1986, is changed as follows:

1. Remove old pages and insert new pages as indicated below. New or changed material is indicated by a vertical bar in the outer margin of the page.

**Remove Pages**

A and B  
None  
i and ii  
1-1 and 1-2  
2-7 and 2-8

**Insert Pages**

a and b  
A/(B Blank)  
i and ii  
1-1 and 1-2  
2-7 and 2-8

**Remove Pages**

3-1 and 3-2  
A-1/(A-2 Blank)  
D-1/(D-2 Blank)  
DA Forms 2028-2  
Cover

**Insert Pages**

3-1 and 3-2  
A-1/(A-2 Blank)  
D-1/(D-2 Blank)  
DA Forms 2028  
Cover

2. File this change sheet in front of the publication for reference purposes.

By Order of the Secretary of the Army:

Official:

  
JOYCE E. MORROW  
*Administrative Assistant to the  
Secretary of the Army*  
0626403

PETER J. SCHOOMAKER  
*General, United States Army  
Chief of Staff*

**DISTRIBUTION:**

To be distributed in accordance with the Initial Distribution Number (IDN) 511713, requirements for TM 11-6625-3135-12.

Change

No. 1

HEADQUARTERS  
DEPARTMENT OF THE ARMY  
Washington, DC, 15 September 1991

**Operators and Organizational  
Maintenance Manual**

**OSCILLOSCOPE AN/USM-488**

(NSN 6625-01-187-7847) (EIC: KNQ)

TM 11-6625-3135-12, 1 October 1986, is changed as follows:

1. Remove old pages and insert new pages as indicated below. New or changed material is indicated by a vertical bar in the margin of the page. Added or revised illustrations and indicated by a bar adjacent to the identification number.

*Remove pages*

i/(ii blank)  
1-1 and 1-2  
2-37 and 2-38  
A-1/(A-2 blank)

*Insert pages*

i/(ii blank)  
1-1 and 1-2  
2-37 and 2-38  
A-1/(A-2 blank)

2. File this change sheet in front of the manual for reference purposes.

Distribution authorized to the Department of Defense and DOD contractors only for official use or for administrative or operational purposes. This determination was made on 15 April 1991. Other requests for this document will be referred to Commander, US Army Communication-Electronics Command and Fort Monmouth, ATTN : AMSEL-LC-LM-LT, Fort Monmouth, New Jersey 07703-5000.

DESTRUCTION NOTICE – Destroy by an method that will prevent disclosure of contents or reconstruction of the document.

By Order of the Secretary of the Army:

CARL E. VUONO  
*General, United States Army*  
*Chief of Staff*

Official:

PATRICIA P. HICKERSON  
*Colonel, United States Army*  
*The Adjutant General*

**DISTRIBUTION:**

To be distributed in accordance with DA Form 12-51-E,  
block 1713, Operator and Unit Maintenance requirements  
for TM 11-6625-3135-12.

INSERT LATEST CHANGED PAGES. DESTROY SUPERSEDED PAGES.

**LIST OF EFFECTIVE PAGES**

**NOTE**

ON CHANGED PAGES, THE PORTION OF THE TEXT AFFECTED BY THE LATEST CHANGE IS INDICATED BY A VERTICAL LINE OR OTHER CHANGE SYMBOL IN THE OUTER MARGIN OF THE PAGE.

Date of issue for original and changed pages are:

Original 0 1 October 1986  
 Change 1 15 September 1991  
 Change 2 13 November 2006

Total number of pages in this publication is 115 consisting of the following:

Page No.	* Change No.	Page No.	*Change No.
Cover.....	2	2-39 through 2-44.....	0
a.....	2	3-1 .....	0
b.....	2	3-2 .....	2
A .....	2	3-3 through 3-12.....	0
B Blank .....	2	A-1 .....	2
i and ii.....	2	A-2 Blank .....	2
iii and 1-0.....	0	B-1 through B-5 .....	0
1-1 and 1-2.....	2	B-6 Blank .....	0
1-3 through 1-11.....	0	C-1 through C-3.....	0
1-12 Blank .....	0	C-4 Blank .....	0
2-1 through 2-7.....	0	D-1.....	2
2-8 .....	2	D-2 Blank.....	2
2-9 through 2-37.....	0	Index-1 through Index-5 .....	0
2-38 .....	1	Index-6 Blank .....	0

\* Zero in this column indicates an original page.

TECHNICAL MANUAL  
NO. 11-6625-3135-12

HEADQUARTERS  
DEPARTMENT OF THE ARMY  
WASHINGTON, D.C., 1 October 1986

**OPERATOR'S AND ORGANIZATIONAL MAINTENANCE MANUAL  
FOR  
OSCILLOSCOPE, AN/USM-488  
(NSN 6625-01-187-7847) (EIC: KNQ)**

**REPORTING ERRORS AND RECOMMENDING IMPROVEMENTS**

You can help improve this manual. If you find any mistakes or if you know of a way to improve the procedures, please let us know. Mail your letter or DA Form 2028 (Recommended Changes to Publications and Blank Forms) directly to: Commander, U. S. Army Aviation and Missile Command, AMSAM-MMC-MA-NP, Redstone Arsenal, AL 35898-5000. A reply will be furnished to you. You may also provide DA Form 2028 information to AMCOM via email, fax or the World Wide Web. Our fax number is: DSN 788-6546 or Commercial 256-842-6546. Our email address is: [2028@redstone.army.mil](mailto:2028@redstone.army.mil). Instructions for sending an electronic 2028 may be found at the back of this manual immediately preceding the hardcopy 2028. For the World Wide Web use: <https://amcom2028.redstone.army.mil>.

**HAZARDOUS MATERIAL INFORMATION**

This document has been reviewed for the presence of solvents containing hazardous materials as defined by the EPCRA 302 and 313 lists by the Engineering, Environment, and Logistics Oversight Office. As of the base document through Change 1, dated 15 September 1991, all references to solvents containing hazardous materials have been removed from this document by substitution with non-hazardous or less hazardous materials where possible.

**OZONE DEPLETING CHEMICAL INFORMATION**

This document has been reviewed for the presence of Class I ozone depleting chemicals by the Engineering, Environment, and Logistics Oversight Office. As of the base document through Change 1, dated 15 September 1991, all references to Class I ozone depleting chemicals have been removed from this document by substitution with chemicals that do not cause atmospheric ozone depletion.

**WARNING** – This document contains technical data whose export is restricted by the Arms Export Control Act (Title 22, U. S. C., Sec 2751 et seq) or the Export Administration Act 1979, as amended, Title 50, U.S.C., App. 2401 et seq.. Violations of these export laws are subject to severe criminal penalties. Disseminate in accordance with provisions of DOD Directive 5230.25.

**DISTRIBUTION STATEMENT D** – Distribution authorized to Department of Defense and DoD contractors only to protect critical technical data on systems or hardware. This determination was made Oct 1986. Other requests shall be referred to: Program Manager, TMDE, ATTN: SFAE-CS-FT-T-TEMOD, Redstone Arsenal, AL 35898-5000.

**DESTRUCTION NOTICE** – Destroy by any method that will prevent disclosure of contents or reconstruction of the document.

TABLE OF CONTENTS

	Page
<b>HOW TO USE THIS MANUAL</b> .....	iii
<b>CHAPTER 1 INTRODUCTION</b> .....	1-1
Section I General Information .....	1-1
Section II Equipment Description .....	1-4
Section III Technical Principles of Operation .....	1-10
<b>CHAPTER 2 OPERATING INSTRUCTIONS</b> .....	2-1
Section I Description and Use of Operator's Controls and Indicators.....	2-2
Section II Operator Preventive Maintenance Checks and Services (PMCS) .....	2-8
Section III Operation Under Usual Conditions .....	2-11
Section IV Operation Under Unusual Conditions .....	2-44
<b>CHAPTER 3 ORGANIZATIONAL MAINTENANCE INSTRUCTIONS</b> .....	3-1
Section I Repair Parts, Special Tools; (TMDE); and Support Equipment.....	3-1
Section II Service Upon Receipt .....	3-2
Section III Troubleshooting .....	3-3
Section IV Maintenance Procedures .....	3-5
Section V Preparation for Storage or Shipment .....	3-12
<b>APPENDIX A REFERENCES</b> .....	A-1
<b>B MAINTENANCE ALLOCATION CHART</b> .....	B-1
<b>C COMPONENTS OF END ITEM AND BASIC ISSUE ITEMS LISTS</b> .....	C-1
<b>D EXPENDABLE SUPPLIES AND MATERIALS LIST</b> .....	D-1
<b>SUBJECT INDEX</b> .....	INDEX-1

---

## HOW TO USE THIS MANUAL

This manual tells you about your Oscilloscope AN/USM-488 and contains instructions about how to use it while testing and maintaining other equipment.

The technical manual for the equipment you are maintaining will give you some guidance in the correct method to make certain connections when testing and troubleshooting with the oscilloscope.

When you first receive your oscilloscope, start at the front of the manual and go all the way through to the back, and become familiar with every part of the manual and the oscilloscope.

This manual has an edge index which will help you find specific information in a hurry. Simply spread the pages on the right edge of the manual until the printed blocks can be seen. Open the manual where the block on the edge of the page lines up with your selected topic printed in the front cover block.

---

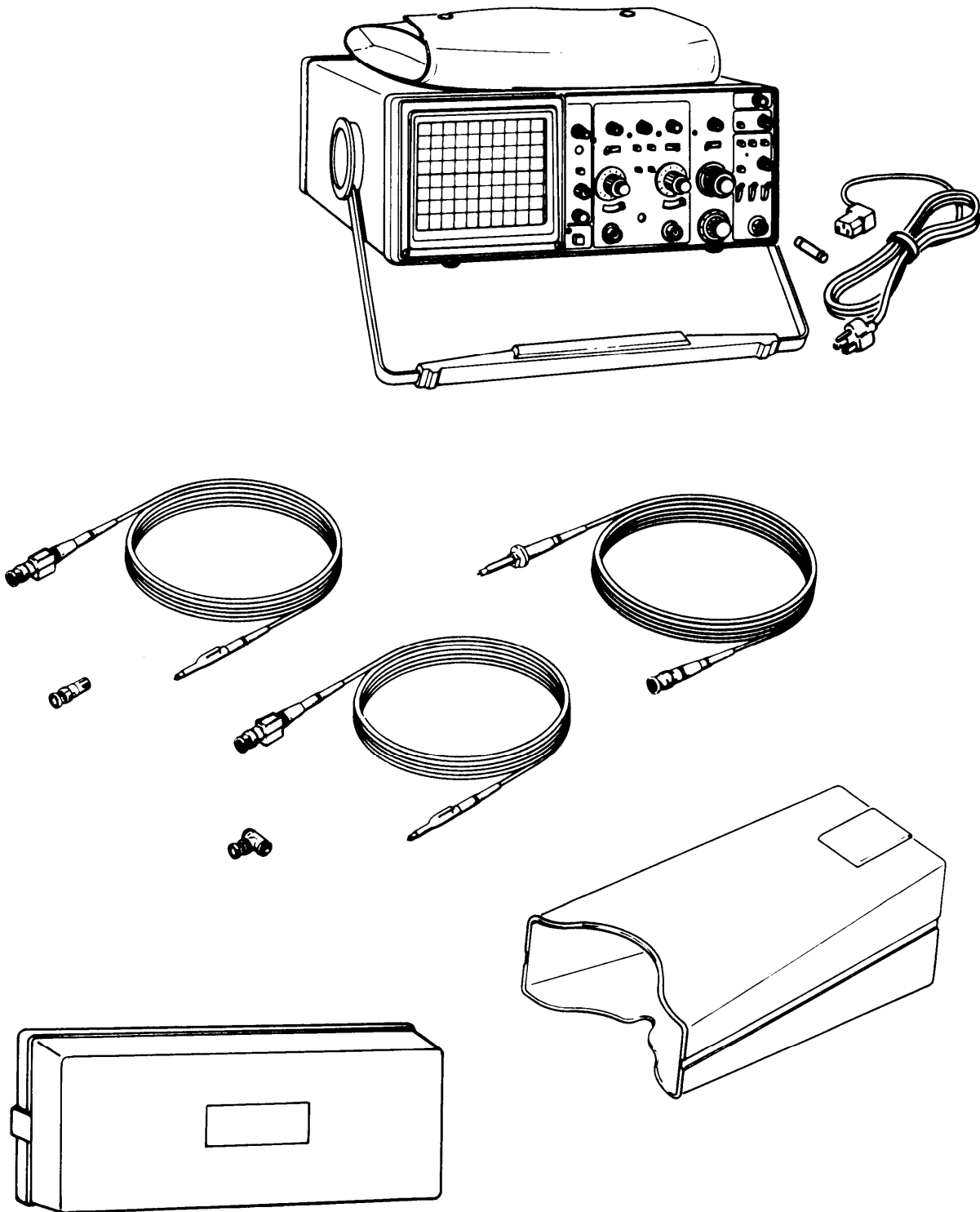

EL9V001

Figure 1-1. Oscilloscope AN/USM-488

# CHAPTER 1 INTRODUCTION

	Para	Page
Consolidated Army Publications and Forms Index.....	1-2	1-1
Destruction of Army Materiel to Prevent Enemy Use .....	1-4	1-1
Equipment Characteristics, Capabilities, and Features .....	1-11	1-4
Equipment Data .....	1-13	1-6
Functional Description .....	1-14	1-10
List of Abbreviations.....	1-10	1-3
Location and Description of Major Components .....	1-12	1-4
Maintenance Forms, Records, and Reports.....	1-3	1-1
Nomenclature Cross-Reference List .....	1-7	1-1
Preparation for Storage or Shipment .....	1-5	1-1
Reporting Equipment Improvement Recommendations (EIR) .....	1-8	1-1
Safety, Care, and Handling .....	1-6	1-1
Scope .....	1-1	1-1
Warranty Information.....	1-9	1-2

## Section I. GENERAL INFORMATION

### 1-1. SCOPE

This manual describes the Oscilloscope, AN/USM-488, and provides instructions for operation, cleaning, inspection, and maintenance. Testing, troubleshooting, and repair procedures are provided for organizational maintenance personnel. The oscilloscope (fig. 1-1) is a portable, bench-type oscilloscope designed for general purpose waveform measurements using single- or dual-trace displays with normal or delayed sweep.

### 1-2. CONSOLIDATED ARMY PUBLICATIONS AND FORMS INDEX

Refer to the latest issue of DA Pam 25-30 to determine whether there are new editions, changes, or additional publications pertaining to the equipment.

### 1-3. MAINTENANCE FORMS, RECORDS, AND REPORTS

a. Reports of Maintenance and Unsatisfactory Equipment. Department of the Army forms and procedures used for equipment maintenance will be those prescribed by DA Pam 750-8, as contained in The Army Maintenance Management System (TAMMS) Users Manual.

b. Reporting of Item and Packaging Discrepancies. Fill out and forward SF 364 (Report of Discrepancy (ROD)) as prescribed in AR 735-11-2/DLAI 4140.55/SECNAVINST 4355.18A/AFJMAN 23-215.

c. Transportation Discrepancy Report (TDR) (SF 361). Fill out and forward Transportation Discrepancy Report (TDR) (SF 361) as prescribed in DA Pam 750-8.

### 1-4. DESTRUCTION OF ARMY ELECTRONICS MATERIEL TO PREVENT ENEMY USE

Destruction of Army electronics materiel to prevent enemy use shall be in accordance with TM 750-244-2.

## 1-5. PREPARATION FOR STORAGE OR SHIPMENT

Storage and shipment procedures are in Chapter 3, Section V.

## 1-6. SAFETY, CARE, AND HANDLING

Observe all WARNINGS, CAUTIONS, and NOTES in this manual. This equipment can be extremely dangerous if these instructions are not followed.

## 1-7. NOMENCLATURE CROSS-REFERENCE LIST

This listing identifies approved nomenclature usage that is different from the official nomenclature:

Common Name	Official Nomenclature
Oscilloscope	Oscilloscope AN/USM-488

## 1-8. REPORTING EQUIPMENT IMPROVEMENT RECOMMENDATIONS (EIR)

If your oscilloscope needs improvement, let us know. Send us an EIR. You, the user, are the only one who can tell us what you don't like about your equipment. Let us know why you don't like the design or performance. Put it on an SF 368 (Product Quality Deficiency Report). Mail it to: Commander, US Army Aviation and Missile Command, AMSAM-MMC-MA-NM, Redstone Arsenal, AL 35898-5000. We'll send you a reply.

## 1-9. WARRANTY INFORMATION

Oscilloscope, AN/USM-488, is warranted by Tektronix, Incorporated for 1 year. The warranty starts on the date of purchase by the original owner. Report all defects, immaterial or workmanship, to your supervisor, who will take appropriate action through your organizational maintenance shop.

## 1-10. LIST OF ABBREVIATIONS

This list identifies abbreviations, and descriptions that are used in this manual,

<b>Abbreviation</b>	<b>Term</b>
AN/USM.....	Army-Navy/General utility-special-maintenance
AR.....	Army Regulation
BII.....	basic issue item
BW.....	Bandwidth
C.....	operator/crew
cm.....	centimeter
crt.....	cathode ray tube
DA.....	Department of the Army
DOD.....	Department of Defense
DISREP.....	discrepancy in shipment report
div.....	division
EAR.....	equipment improvement recommendation
Hz.....	hertz (formerly cps)
kHz.....	kilohertz
MAC.....	maintenance allocation chart
MHz.....	megahertz
mV.....	millivolt
ns.....	nanosecond
NON.....	National/NATO stock number
o.....	organizational maintenance
pF.....	picofarad
p.p.....	peak-to-peak
PMCS.....	preventive maintenance checks and services
rqr.....	required
s.....	second
sec/div.....	seconds per division
SIR.....	source, maintainability, and recoverability
TAMES.....	The Army Maintenance Management System
TIDE.....	test, measurement, and diagnostic equipment
U/M.....	unit of measure
us.....	microsecond
uV.....	microvolt
VITS.....	vertical interval test signal

## Section II. EQUIPMENT DESCRIPTION

### 1-11. EQUIPMENT CHARACTERISTICS, CAPABILITIES, AND FEATURES

The oscilloscope is a rugged, lightweight, dual-channel instrument allowing visual evaluation of electrical circuits.

#### a. Characteristics.

- Measures ac voltage and dc voltage
- Measures frequency
- Measures nondelayed time
- Measures rise and fall times
- Algebraically adds signals applied to channels 1 and 2

#### b. Capabilities and Features.

- Vertical system provides calibrated deflection factors from 2 inV per division to 5 V per division
- Trigger circuits enable stable triggering over full bandwidth of vertical system
- Horizontal system provides calibrated sweep speeds from 0.5s per division to 50 ns per division
- Horizontal system provides delayed sweep feature
- Magnifier circuit extends maximum sweep speed to 5 ns per division

### 1-12. LOCATION AND DESCRIPTION OF MAJOR COMPONENTS

OSCILLOSCOPE (1) — A self-contained, multi-range measuring instrument that allows visual evaluation of electrical circuits. It measures and indicates various electrical characteristics needed to test and troubleshoot electrical equipment. The handle can be adjusted as a stand.

POUCH (2) — Provides storage for probes and small components.

AC POWER CORD (3) — Provides for operation from the ac power line.

1X PROBE PACKAGE (4) — Provides nonattenuated input to oscilloscope.

10X PROBE PACKAGE (5) — Attenuates input signal by factor of 10.

VIEWING HOOD (6) — Allows operator to view crt display in bright light.

COVER (7) — Protects crt screen and front panel controls.

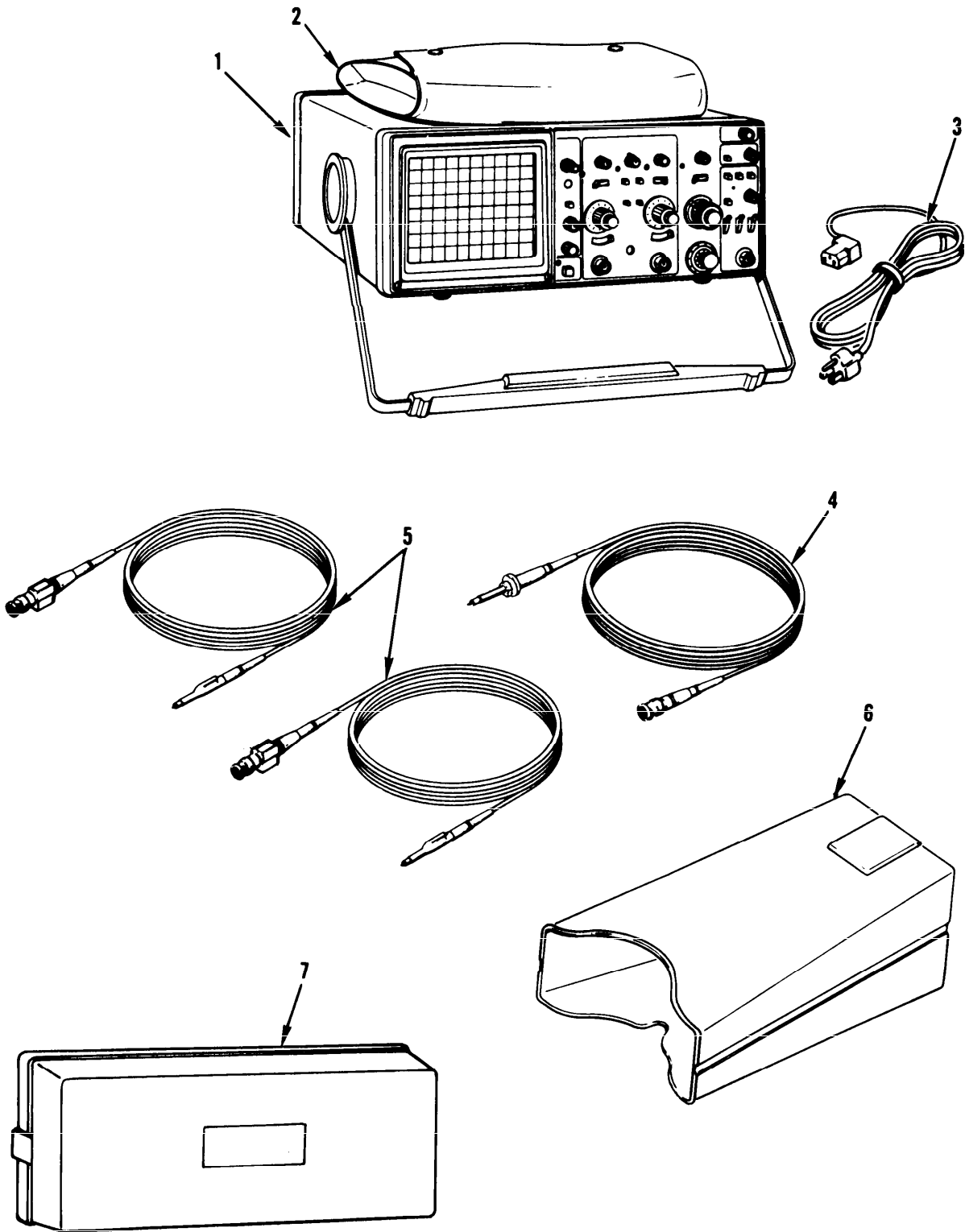

EL9V002

**1-13. EQUIPMENT DATA**

**VERTICAL DEFLECTION SYSTEM:**

Deflection Factor

Range . . . . .	2 m V to 5 V per division
Accuracy at 52-95°F(15-35°C)	±2%
Accuracy at 32-122°F(0-50°C)	±3%
Range of VOLTS/DIV Control . . . . .	Continuously variable between settings, Increases deflection factor by at least 2.5 to 1

Step Response (Rise Time)

32-95° F (0-35° C)	
5 mV to 5 V per Division . . . . .	3.5 ns or less
2 m V per Division . . . . .	3.9 ns or less
52-122° F (35-50° C)	
5 mV to 5 V per Division . . . . .	3.9 ns or less
2 m V per Division, . . . . .	4.4 ns or less

Aberrations (Positive-going Step)

2 m V to 0.5 V per Division . . . . .	4% peak-to-peak
1 V to 5 V per Division . . . . .	12% peak-to-peak

Bandwidth (-3 dB Point)

32-95° F (0-35° C)	
5 m V to 5 V per Division . . . . .	dc to at least 100 MHz
2 m V per Division . . . . .	dc to at least 90 MHz
95-122° F (35-50°C)	
5 m V to 5 V per Division . . . . .	dc to at least 90 MHz
2 m V per Division . . . . .	dc to at least 80 MHz

AC Coupled Lower Limit . . . . . 10 Hz or less at -3 dB

Bandwidth Limiter . . . . . Upper limits (-3 dB bandpass at 20 MHz, ± 10%)

Chop Mode Switching Rate . . . . . 500 kHz ±30%

Input Characteristics

Resistance . . . . .	1 Megohm ±2%
Capacitance . . . . .	20 pF ±2 pF

Maximum Safe Input Voltage

DC Coupled . . . . .	400 V (dc + peak ac) or 800 V peak-to-peak to 10 kHz or less
AC Coupled . . . . .	400 V (dc + peak ac) or 800 V peak-to-peak to 10 kHz or less

Common Mode Rejection Ratio . . . . . At least 20 to 1 at 80 MHz

Input Current . . . . . 1.0 nA or less (0.5 division trace shift at 2 m V per division)

Trace Shift with VOLTS/DIV Switch

Rotation . . . . . 0.75 division or less

Trace Shift as VOLTS/DIV Variable Control

is Rotated . . . . . 1.0 division or less

Trace Shift With Invert. . . . . 1.5 divisions or less

Channel Isolation . . . . . Greater than 100 to 1 at 50 MHz

POSITION Control Range . . . . . At least ±11 divisions from graticule center

**TRIGGER SYSTEM:**

A Trigger Sensitivity	
P-P AUTO/TV LINE and NORM Modes	
Internal .....	0.35 division at 10 MHz, 1.0 division at 60 MHz, 1.5 divisions at 100 MHz
External .....	35 m V at 10 MHz, 120 m V at 60 MHz, 150 m V at 100 MHz
High-Frequency Rejection .....	Attenuates signals above 40 kHz (-3 dB point at 40 kHz $\pm 25\%$ )
Low-Frequency Rejection .....	Attenuates signals below 40 kHz (-3 dB point at 40 kHz $\pm 25\%$ )
Lowest Useable Frequency in P-P	
AUTO Mode .....	20 Hz with 1.0 division internal or 100 m V external
TV FIELD Mode .....	1.0 division of composite sync
External Trigger Input	
Maximum Input Voltage .....	400 V (dc + peak ac) or 800 V ac peak-to-peak
Input Resistance .....	1 Megohm $\pm 2\%$
Input Capacitance .....	20 pF $\pm 2.5$ pF
AC Coupled .....	10 Hz or less at lower -3 dB point
Level Control Range	
A TRIGGER (Normal)	
INT .....	Can be set to any point of the trace that can be displayed
EXT. DC .....	At least+ 1.6 V (3.2 V peak-to-peak)
EXT. DC $\div 10$ .....	At least $\pm 16$ V (32 V peak-to-peak)
B TRIGGER (Internal) .....	Can be set to any point of trace that can be displayed
VAR HOLDOFF Control .....	Increases A sweep holdoff time by at least a factor of 10

**TRIGGER VIEW SYSTEM:**

Deflection Factor	
Internal .....	Same as vertical
External	
AC and DC .....	100 m V per division
DC $\div 10$ .....	1 V per division
Accuracy .....	$\pm 20\%$
Delay Difference Between EXT INPUT and Either Vertical Channel .....	
	Less than 2.0 ns

**HORIZONTAL DEFLECTION SYSTEM:**

Sweep Rate Calibrated Range

A sweep .....	0.5 second to 0.05 us per division. X10 magnifier extends maximum sweep speed to 5 ns per division
B Sweep .....	50 ms to 0.05us per division. X10 magnifier extends maximum sweep speed to 5 ns per division
Sweep Rate Accuracy at 59-95° F (15-35° C)...	±2% unmagnified, ±3% magnified
Sweep Rate Accuracy at 32-122° F (0-50° C)...	±3% unmagnified, ±4% magnified
POSITION Control Range .....	Start of sweep to 10th division will position past center vertical graticule line in X1 or 100th division in X10
Sweep Linearity .....	±5%
Variable Control Range .....	Continuously variable between calibrated settings. Reduces A and B sweep speeds by at least a factor of 2.5
Sweep Length .....	Greater than 10 divisions
A/B SWP SEP Range .....	±3.5 divisions or greater
Delay Time .....	Applies to 0.5 us per division and slower
Dial Control Range .....	<0.5 + 300 ns to >10 divisions
Jitter .....	0.005% of the maximum delay time
Time Measurement Accuracy	
59-95° F (15-35° C) .....	±1%+ 0.01 major dial division
32-122° F (0-50° C) .....	±2%+ 0.01 major dial division

**X-Y OPERATION:**

Deflection Factors .....	Same as vertical deflection system (with VOLTS/DIV variable controls in CAL detent)
Accuracy	
X-Axis at 59-95° F (15-35° C) .....	±3%
X-Axis at 32-122° F (0-50° C) .....	±4%
Y-Axis .....	Same as vertical deflection system
Bandwidth (--3 dB Point)	
X-Axis .....	dc to at least 2.5 MHz
Y-Axis .....	Same as vertical deflection system
Phase Difference Between X- and Y-Axis	
Amplifiers, .....	±3% from dc to 150kHz

**AMPLITUDE CALIBRATOR:**

Output Voltage of AMP CAL Connector .....	0.5V ±2%
Repetition Rate.....	1 kHz ±20%

**Z-AXIS INPUT:**

Sensitivity .....	5 V causes noticeable modulation. Positive-going input decreases intensity. Useable frequency range is dc to 20 MHz.
Maximum Safe Input Voltage .....	30 V (dc + peak) or 30 V ac peak-to-peak at 1 kHz or less
Input Resistance .....	10 kilo hms ±10%

**POWER SOURCE:**

Line Voltage Ranges . . . . .	90 V ac to 250 V ac
Line Frequency . . . . .	48 to 440 Hz
Maximum Power Consumption . . . . .	40 W (70 VA)
Line Fuse . . . . .	1.0 A, 250 V, Slow-blow

**CATHODE RAY TUBE:**

Display Area . . . . .	80mmx100mm
Standard Phosphor . . . . .	P31
Nominal Accelerating Voltage . . . . .	14 kV

**ENVIRONMENTAL CHARACTERISTICS:**

Operating Temperature . . . . .	32-122° F (0-50° C)
Nonoperating Temperature . . . . .	-67 to +167°F (--55 to + 75°C)
Operating Altitude . . . . .	Up to 15,000 ft (4,500m). Maximum temperature decreased 1° C per 1,000 ft above 5,000 ft
Nonoperating Altitude . . . . .	To 50,000 ft (15,000 m)
Operating Humidity . . . . .	95% at 86-122° F (30-50° C)
Nonoperating Humidity . . . . .	95% at 86-140° F (30-60° C)
Vibration (Operating) . . . . .	Can withstand total displacement of 0.01 5 inch p-p (2.4 g's at 55 Hz) along all three axes, with frequency varied from 10 Hz to 55 Hz, for period of 15 minutes
Electromagnetic Interference . . . . .	Meets requirements of MIL STD-461B Pt 4

**PHYSICAL CHARACTERISTICS:**

Weight with Accessories . . . . .	20.0 lb (9.1 kg)
Weight without Accessories . . . . .	13.5 lb (6.1 kg)
Domestic Shipping Weight . . . . .	24.1 lb (10.9 kg)
Height with Empty Pouch . . . . .	5.9 in. (150 mm)
Height without Pouch . . . . .	5.4 in. (137 mm)
Width with Handle . . . . .	14.2 in. (360 mm)
Width without Handle . . . . .	12.9 in. (328 mm)
Length with Front Cover . . . . .	17.5 in. (445 mm)
Length without Front Cover.. . . . .	17.3 in. (440 mm)
Length with Handle Extended . . . . .	20.1 in. (511 mm)

### Section III. TECHNICAL PRINCIPLES OF OPERATION

#### 1-14. FUNCTIONAL DESCRIPTION

The following is a basic functional description of the oscilloscope. Refer to fig. 1-2 for a block diagram.

- ① There are two vertical attenuators (one for each channel). The attenuator circuits provide control of input coupling, vertical deflection factor, and variable volts-per-division gain. An invert circuit in the channel 2 attenuator allows you to invert the channel 2 input signal.
- ② The vertical preamp and output circuit amplifies the input signals. This makes the signal level high enough for vertical deflection of the electron beam in the crt. The dynamic range of the amplifier can be limited with the beam find switch. The amplifier also intensifies the trace and limits horizontal deflection.
- ③ The A sweep generator and logic circuit produces a linear voltage ramp for horizontal deflection of the crt beam. The sweep generator also produces signals that generate correct timing of the crt unblinking and intensity levels.
- ④ The A trigger circuitry uses either an internal signal, external trigger, or ac line trigger signal to develop a gate signal for the A sweep generator. The B trigger circuitry uses only the internal trigger signal to gate the B signal generator.
- ⑤ The alternate B sweep circuitry produces a linear voltage ramp that is amplified by the horizontal amplifier. This provides the B sweep horizontal deflection on the crt. The alternate B sweep circuitry also produces sweep-switching signals that control the display of the A and B sweeps, and gate signals used to establish the crt unblinking and intensity levels for the A intensified and B sweep displays.
- ⑥ The X-Y amplifier amplifies the channel 1 signal from the internal circuit and applies it to the horizontal amplifier. The horizontal amplifier provides output signals to drive the crt horizontal deflection plates.
- ⑦ The power supply converts ac power-line voltage into voltages needed for oscilloscope operation. The Z-axis amplifier uses several input signal sources to control the crt intensity level.
- ⑧ The crt provides a visual display of the electrical properties of the circuit or signal under examination.

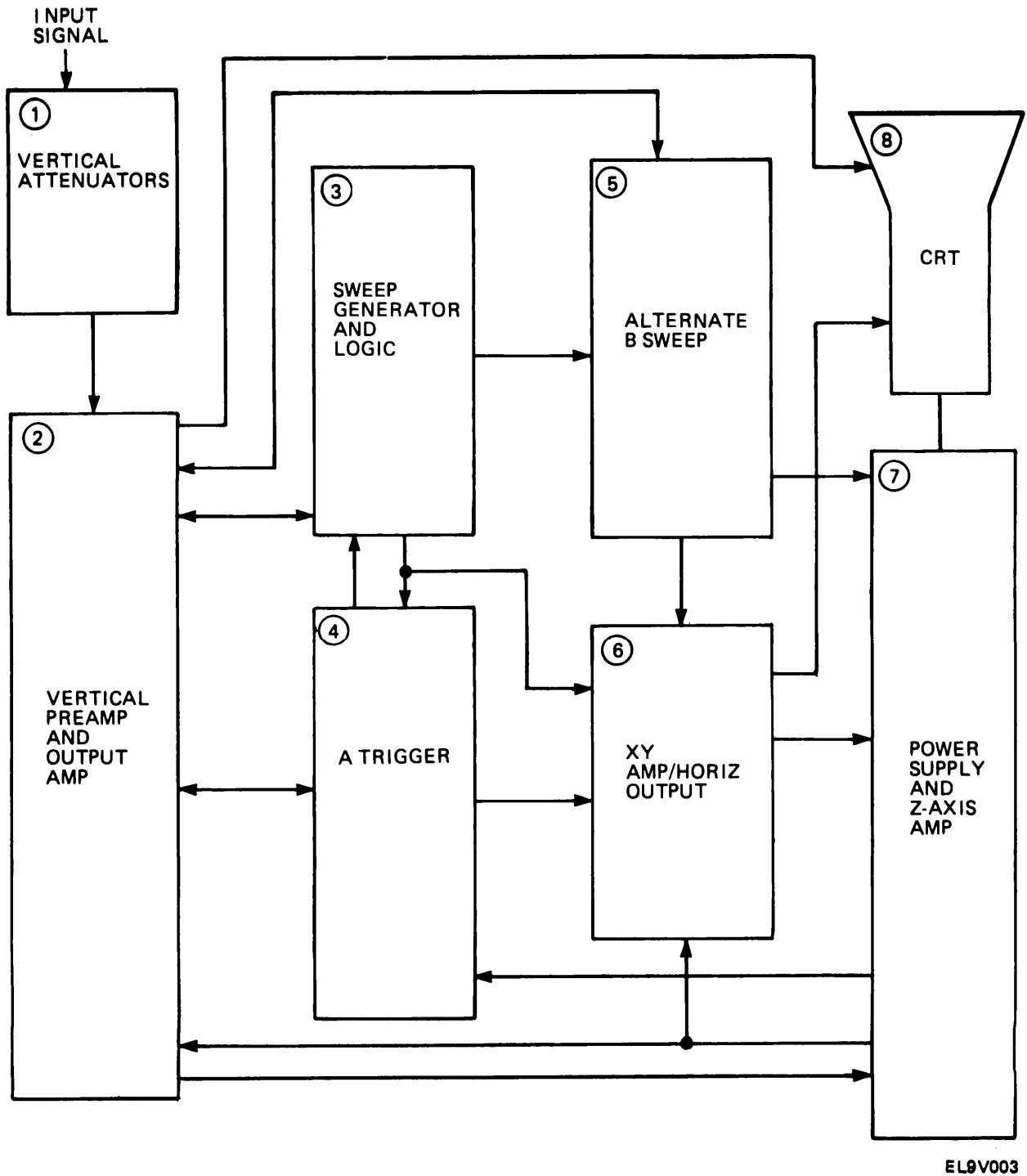

EL9V003

Figure 1-2. AN/USM-488 Oscilloscope Block Diagram



## CHAPTER 2 OPERATING INSTRUCTIONS

	Para	Page
General Operator Preventive Maintenance Checks and Services .....	2-1	2-8
Operating Procedures .....	2-3	2-11
Operation in Unusual Weather .....	2-4	2-44
PMCS Table .....	2-2	2-8

## Section I. DESCRIPTION AND USE OF OPERATOR'S CONTROLS AND INDICATORS

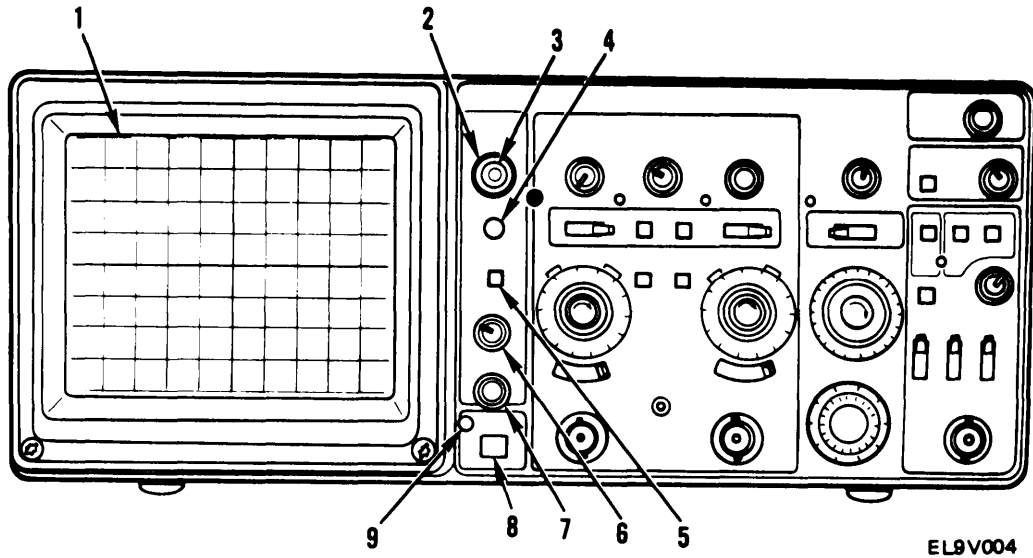

Key	Control Or Indicator	Function
1	Cathode Ray Tube	Provides visual display of electrical properties of circuit under examination
2	A INTENSITY Control	Controls brightness of A sweep trace
3	B INTENSITY Control	Controls brightness of B sweep trace
4	TRACE ROTATION Control	Screwdriver adjustment used to align trace with horizontal graticule line
5	BEAM FIND Switch	When held depressed, compresses display to within graticule area to aid in locating off-screen displays
6	SCALE ILLUM Control	Adjusts brightness of graticule illumination
7	FOCUS Control	Adjusts for optimum display definition
8	POWER Switch	Turns oscilloscope power on and off
9	POWER Indicator	When illuminated, indicates power applied to oscilloscope

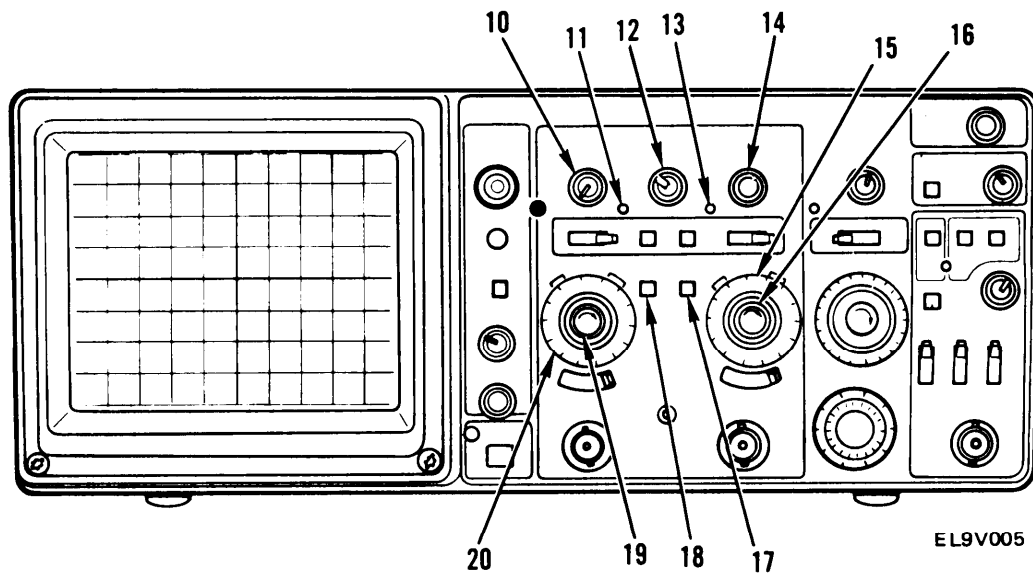

Key	Control Or Indicator	Function
10	POSITION Control	Controls vertical position of channel 1 display
11	UNCAL Indicator	When illuminated, indicates channel 1 VOLTS/DIV control not in calibrated position
12	A/B SWP SEP Control	Vertically positions B sweep trace with respect to A sweep trace when HORIZONTAL ALT mode is selected
13	UNCAL Indicator	When illuminated, indicates channel 2 VOLTS/DIV control not in calibrated position
14	POSITION Control	Controls vertical position of channel 2 display
15	CH 2 VOLTS/DIV Switch	Used to select channel 2 vertical deflection factor
16	CH 2 VOLTS/DIV Variable Control	When rotated out of detent, provides variable, uncalibrated deflection factors between calibrated settings of channel 2 VOLTS/DIV switch
17	BW LIMIT Switch	When depressed, limits bandwidth of vertical amplifier and A trigger system to approximately 20 MHz
18	TRIG VIEW Switch	While held in, sample of signal present in A trigger amplifier displayed on crt
19	CH 1 VOLTS/DIV Variable Control	When rotated out of detent, provides variable, uncalibrated deflection factors between calibrated settings of channel 1 VOLTS/DIV switch
20	CH 1 VOLTS/DIV Switch	Used to select channel 1 vertical deflection factor

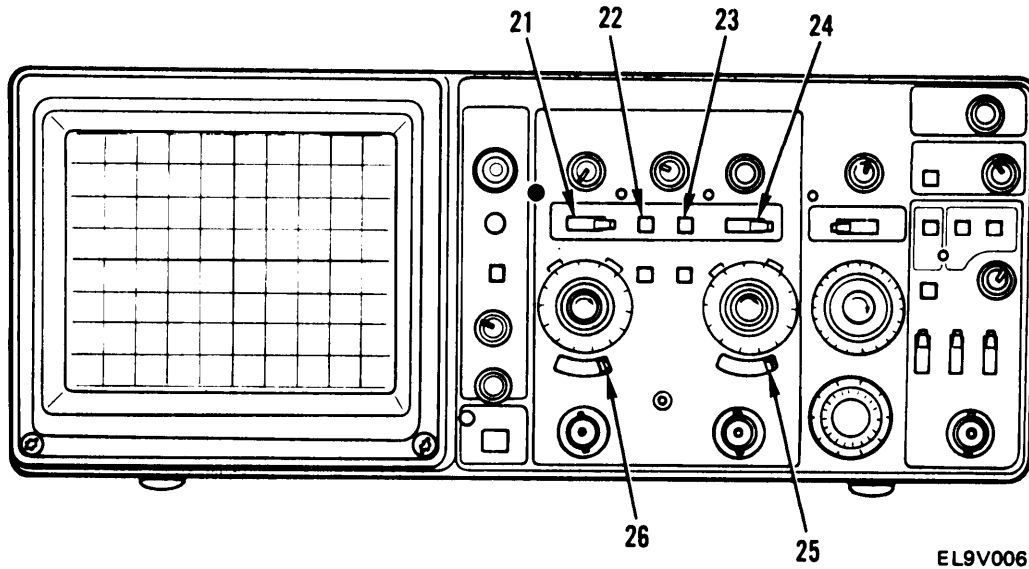

Key	Control Or Indicator	Function
21	VERTICAL MODE CH 1/BOTH/CH 2 Switch	When set to CH 1, selects only channel 1 input signal for display. When set to BOTH, selects both channel 1 and channel 2 input signals for display. When set to CH 2, selects only channel 2 input signal for display
22	CH 1 TRIGGER SOURCE Switch	When depressed, selects signal applied to CH 1 OR X INPUT connector as trigger source
22-23	COMPOSITE	When CH 1 and CH 2 switches are either both depressed or both released, composite trigger source is selected, Trigger source is then determined by signals selected for display by the VERTICAL MODE switches
23	CH 2 TRIGGER SOURCE Switch	When depressed, selects signal applied to CH 2 OR Y INPUT connector as trigger source
24	VERTICAL MODE ADD/ALT/CHOP Switch	When set to ADD, displays algebraic sum of channel 1 and channel 2 input signals. When set to ALT, displays channel 1 and channel 2 input signals alternately at end of each trace. When set to CHOP, displays channel 1 and channel 2 input signals alternately during sweep time
25	AC/GND/DC Switch	Three-position switch to select method of coupling input signal to channel 2 deflection system. It also establishes DC ground reference line on crt.
26	AC/GND/DC Switch	Three-position switch to select method of coupling input signal to channel 1 deflection system. It also establishes DC ground reference line on crt.

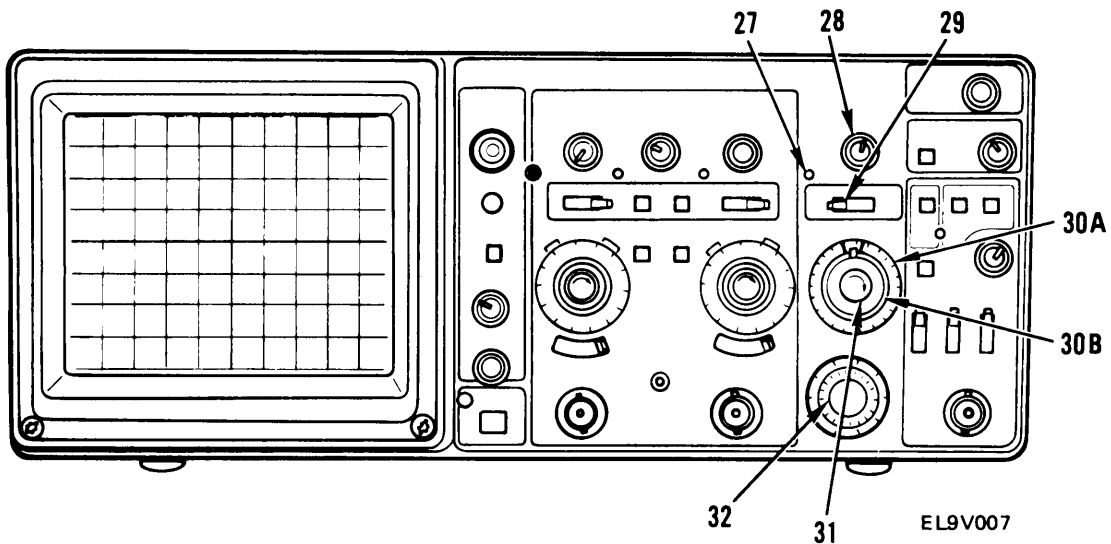

Key	Control Or Indicator	Function
27	UNCAL Indicator	When illuminated, indicates SEC/DIV variable control is not in calibrated position
28	POSITION Control	Moves A sweep and B sweep displays horizontally and horizontally positions X-axis in X-Y mode of operation
29	HORIZONTAL MODE A/ALT/B Switch	Determines mode of operation for horizontal deflection system. When set to A, horizontal deflection is provided by A sweep generator. When set to ALT, display alternates between A sweep and B delayed sweep. When set to B, horizontal deflection is provided by B sweep generator
30A	A SEC/DIV Switch	Used to select sweep speeds for A and B sweep generators in a 1, 2, 5 sequence. To lock A and B sweeps together, pull the B SEC/DIV switch out and align the pointer on the B SEC/DIV switch between the two markers on the A SEC/DIV switch, then release the switch. If the two switches are not locked together, B sweep can be delayed. Setting A SEC/DIV switch to X-Y locks the A sweep in horizontal mode.
30B	B SEC/DIV Switch	
31	SEC/DIV Variable Control and X10 Multiplier Switch	Provides continuously variable, uncalibrated sweep speeds. Pulling control out actuates X 10 magnifier switch, which expands crt display by a factor of 10
32	B DELAY TIME POSITION Control	Selects amount of delay time between start of A sweep and start of B sweep. Delay time is variable from 0.5 to 10 times A SEC/DIV switch setting

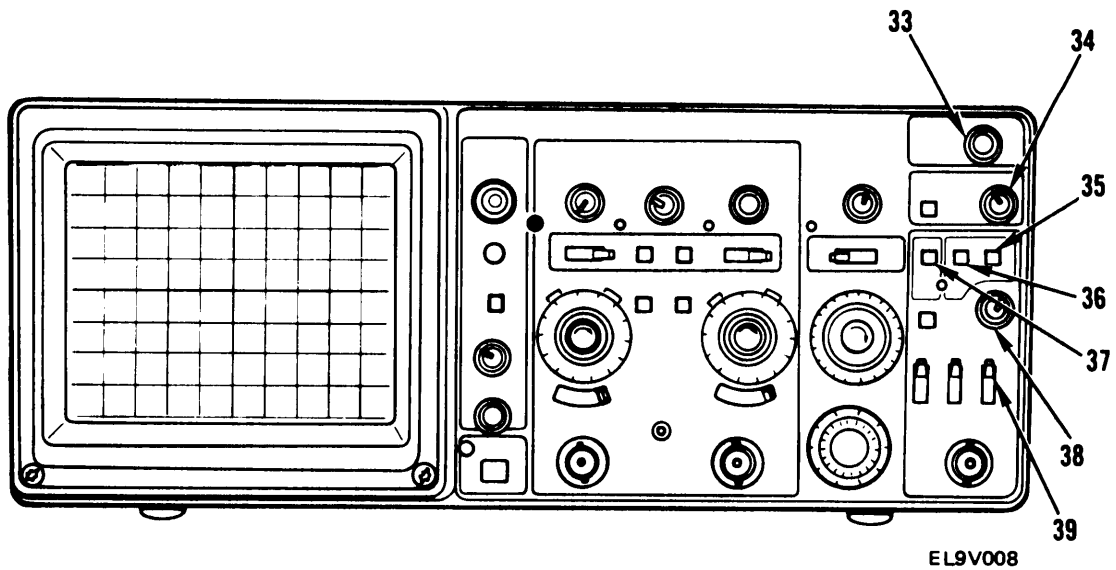

Key	Control Or Indicator	Function
33	VAR HOLDOFF Control	Provides continuous control of hold off time between sweeps and increases hold off time by at least a factor of 10
34	B TRIGGER LEVEL Control	Selects amplitude point on trigger signal at which B sweep is triggered
35	A TRIGGER NORM Switch	When depressed, sweep is initiated when adequate trigger signal is applied
35-36	TV FIELD	Depressing both P-P AUTO and NORM pushbuttons permits triggering on television field signals
36	A TRIGGER P-P AUTO/TV LINE Switch	Permits triggering on waveforms and television lines having repetition rate of at least 20 Hz. Sweep free-runs in absence of adequate trigger signal
37	A TRIGGER SGL SWP RESET Switch	When momentarily depressed, arms A trigger circuit for single-sweep display
38	A TRIGGER LEVEL Control	Selects amplitude point on trigger signal at which A sweep is triggered
39	A EXT COUPLING Switch	Three-position switch that determines method used to couple external signals from EXT INPUT connector to A trigger circuit

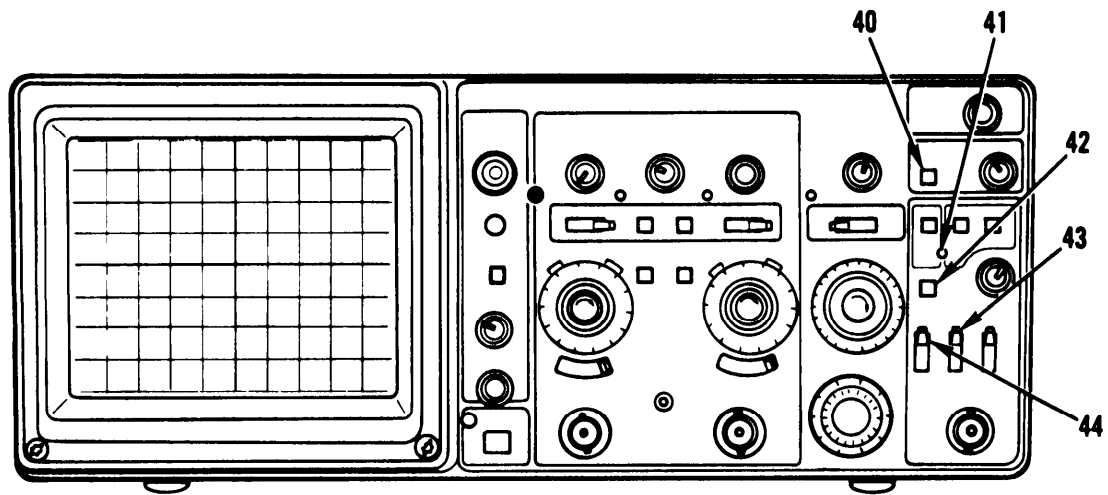

EL9V009

Key	Control Or Indicator	Function
40	B TRIGGER SLOPE Switch	Selects slope of signal that triggers B channel sweep
41	TRIG'D/READY Indicator	Illuminates when either P-P AUTO or NORM trigger mode is selected
42	A TRIGGER SLOPE Switch	Selects slope of signal that triggers A channel sweep
43	A SOURCE Switch	Three-position switch that determines source of trigger signal coupled to input of A trigger circuit. When set to INT, permits triggering on signal applied to CH 1 OR X connector or CH 2 OR Y connector. When set to LINE, selects ac line voltage as trigger signal. When set to EXT, permits triggering on signals applied to EXT INPUT connector
44	A TRIG BW Switch	Three-position switch that selects trigger bandpass frequencies for A trigger circuit. When set to FULL, allows all frequency components to pass. When set to HF REJ, attenuates all trigger signals above approximately 40 kHz. When set to LF REJ, attenuates all trigger signals below approximately 40 kHz

## Section II. OPERATOR PREVENTIVE MAINTENANCE CHECKS AND SERVICES (PMCS)

### 2-1. GENERAL

Operator Preventive Maintenance Checks and Services (PMCS) are the required inspection and care of your equipment necessary to keep it in good operating condition.

- a. **Before You Operate.** Always keep in mind the CAUTIONS and WARNINGS. Perform your before - PMCS.
- b. **While You Operate.** Always keep in mind the CAUTIONS and WARNINGS. Perform your during - PMCS.
- c. **After You Operate.** Be sure to perform your after-operation PMCS.
- d. **If Your Equipment Fails to Operate.** Troubleshoot with proper equipment. Report any deficiencies using the proper forms. See DA Pam 750-8.

### 2-2. PMCS TABLE

The PMCS are shown in table 2-1.

- a. **Item Number Column.** The numbers appearing in this column are in the order the work should be performed. The numbers are keyed to fig. 2-1 to identify work locations. This column shall also be used as a source of item numbers for the TM Number Column on DA Form 2404 (Equipment Inspection and Maintenance Worksheet) in recording results of PMCS.
- b. **Interval Column.** This column indicates whether PMCS is performed before operation (B), during operation (D), after operation (A), or weekly (W).
- c. **Item to be Inspected Column.** This column identifies the item to be inspected.
- d. **Procedures Column.** This column contains a brief description of the check or service to be performed and step-by-step procedures.
- e. **Equipment is Not Ready If Column.** This column identifies the condition that prevents the equipment from being ready for operation.

**Table 2-1. Operator Preventive Maintenance Checks and Services**

WARNING

High voltage is used in the operation of this equipment. Death on contact may result if you fail to observe safety precautions. Learn where there may be dangerous voltages present.

B = Before

D = During

A = After

W = Weekly

Item No.	Interval				Item to be Inspected	Procedure	Equipment is Not Ready if:
	B	D	A	W			
1	•			•	Cabinet Front Panel, and Viewing Hood	Inspect case, viewing hood, cover, and front panel for cracks, scratches, deformation, loose or missing hardware or gaskets.	Cabinet or front panel is badly damaged.
2	•	•	•	•	Front Panel Controls	Inspect for missing, loose, or damaged knobs, buttons, and controls.	Knobs, buttons, or controls missing or damaged.
3	•		•	•	Connectors	Inspect for broken shells, cracked insulation, deformed contacts, and dirt in connector.	Connector shell is broken, insulation is cracked, or contacts deformed.
4	•	•	•	•	Carrying Handle	Inspect for correct operation.	
5	•			•	AC Power Cord	Inspect for frayed, broken, or abraded insulation, broken wires, or damaged connectors. Replace if damaged.	Cord shows any signs of damage.
6	•			•	Probe Package	Inspect for missing items, bent pins, broken or frayed cables, and damaged connectors. Replace if damaged.	Cables frayed or broken, pins broken, or connectors damaged.

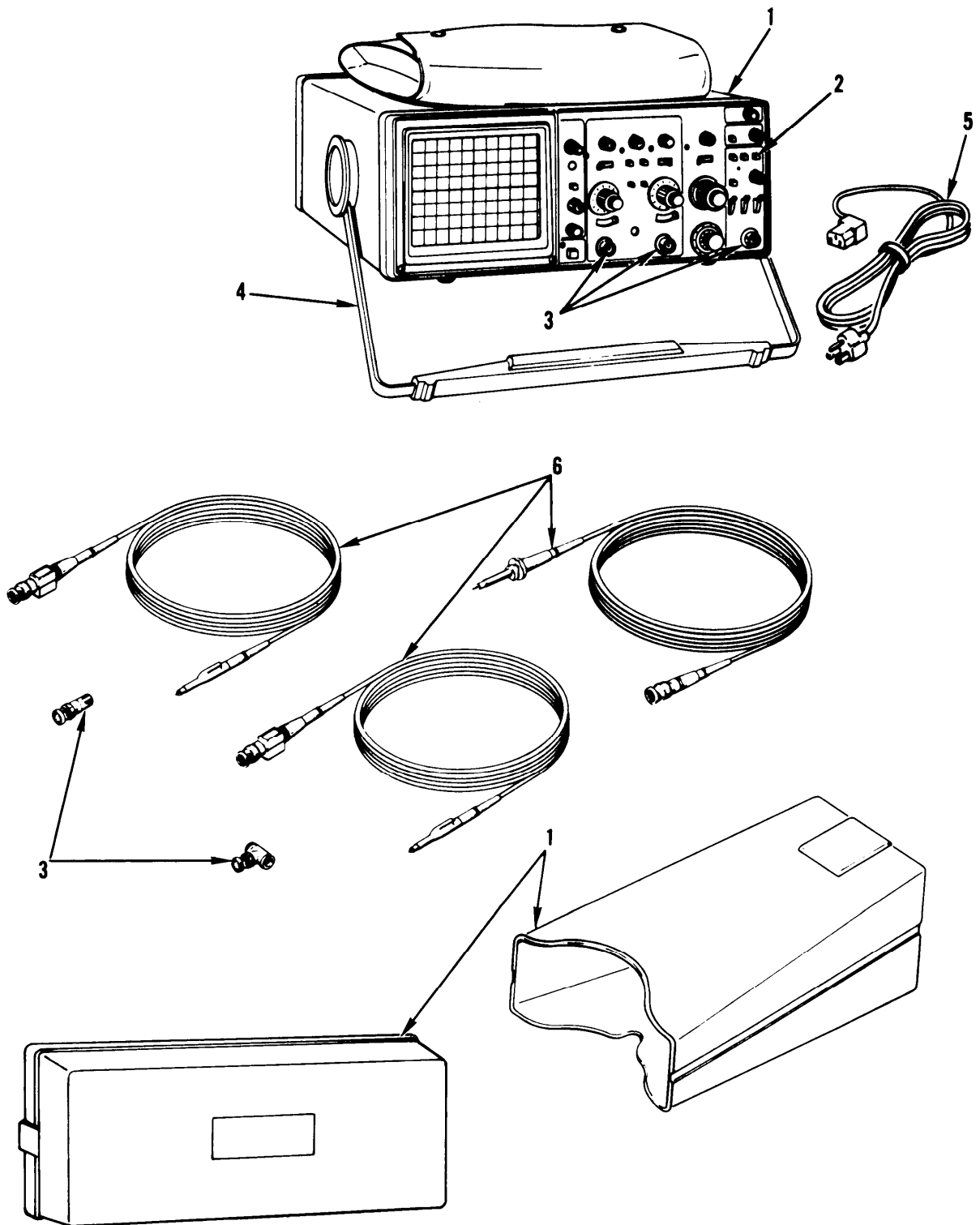

Figure 2-1. Oscilloscope PMCS Location Diagram

EL9V010

## Section III. OPERATION UNDER USUAL CONDITIONS

### 2-3. OPERATING PROCEDURES

After becoming familiar with the capabilities of the oscilloscope, an operator can easily develop convenient methods for making measurements. The following paragraphs provide recommended methods for making basic measurements, such as probe compensation, voltage measurement, non-delayed time measurement, obtaining television displays, delayed sweep magnification, and delayed sweep time measurements.

#### a. Obtaining Baseline Trace.

1. Set POWER ON/ OFF switch (1) to OFF and plug power cord into ac source.
2. Preset front panel controls as shown in table 2-2.
3. Depress POWER ON/ OFF switch (1) to ON.
4. Adjust A INTENSITY control (2) to desired brightness of display.
5. Adjust channel 1 vertical POSITION control (3) to center trace vertically on screen.
6. Adjust horizontal POSITION control (4) to center trace horizontally on screen.

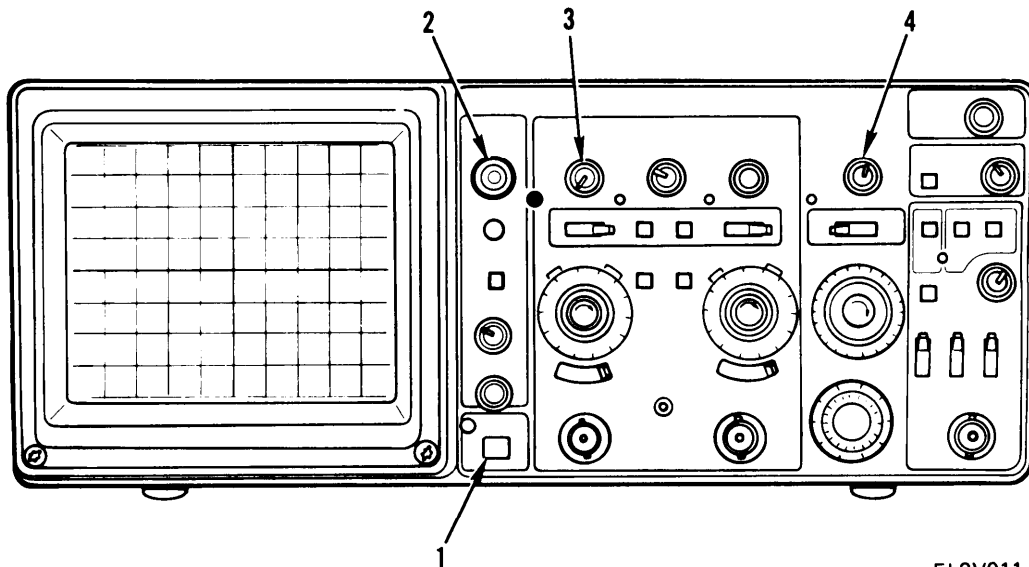

EL9V011

Table 2-2. Controls, Preset Positions

Control	Position
Display	
A AND B INTENSITY FOCUS	Fully counterclockwise Midrange
Vertical (Both Channels)	
POSITION	Midrange
POSITION and INVERT (Channel 2 only)	Midrange and pushed in
VERTICAL MODE CH 1/BOTH/CH 2	CH 1
TRIGGER SOURCE	COMPOSITE (both in or both out)
BW LIMIT	Off (button out)
VOLTS/DIV Switch	50 mV
VOLTS/DIV Variable Control	CAL detent
AC/GND/DC	AC
Horizontal	
A/B SWP SEP	Midrange
POSITION	Midrange
MODE	A
A AND B SEC/DIV Switch	0.5 ms
SEC/DIV Variable Control	CAL detent
X10 Multiplier	Off (knob in)
B DELAY TIME POSITION	Fully counterclockwise
B Trigger	
SLOPE	out
LEVEL	Fully clockwise
A Trigger	
VAR HOLDOFF	NORM
TRIGGER MODE P-P AUTO/TV LINE	In
SLOPE	out
LEVEL	Midrange
A TRIG BW	FULL
A SOURCE	INT
A EXT COUPLING	AC

## b. Probe Compensation.

**NOTE**

Misadjustment of probe compensation is a common source of measurement error. To ensure optimum measurement accuracy, always compensate the oscilloscope probes before making measurements.

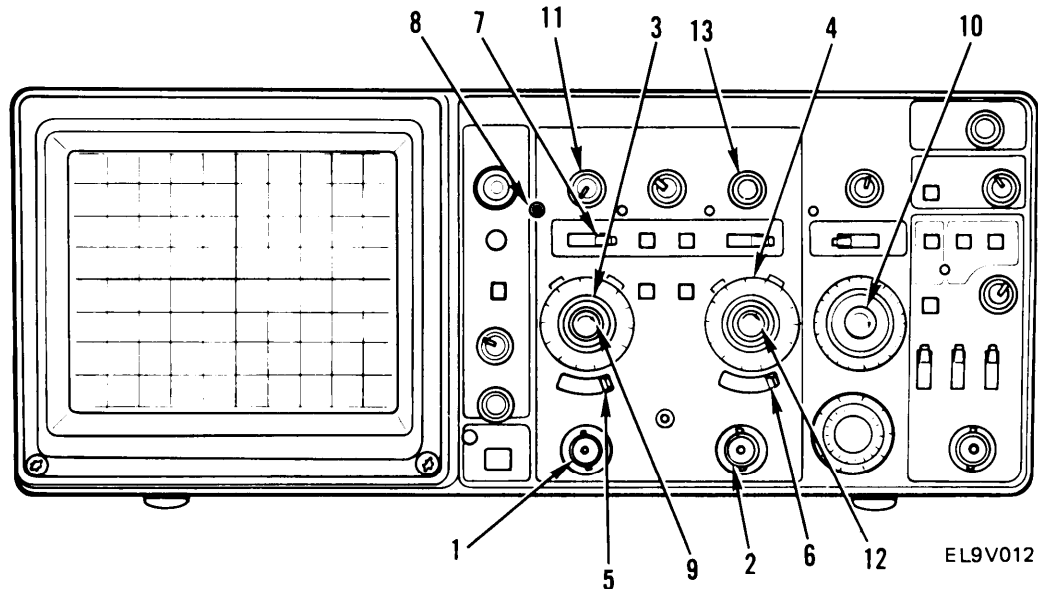

1. Obtain baseline trace as described in para 2-3a.
2. Connect one 10X probe to CH 1 OR X connector (1) and one 10X probe to CH 2 OR Y connector (2).
3. Set both CH 1 and CH 2 VOLTS/DIV switches (3 and 4) to 0.1 10X PROBE.
4. Set both AC/GND/DC switches (5 and 6) to DC.
5. Set VERTICAL MODE CH 1/BOTH/CH 2 switch (7) to CH 1.
6. Insert tip of channel 1 probe into AMP CAL connector (8) and adjust CH 1 VOLTS/DIV variable control (9) to obtain display amplitude of five vertical divisions.
7. Set A SEC/DIV switch (10) to display 5 cycles of AMP CAL signal.
8. Using channel 1 vertical POSITION control (11), vertically center display on crt screen.
9. Using low-reactance alignment tool, adjust low-frequency compensation control on probe compensation box to obtain best wave form with flattest top.

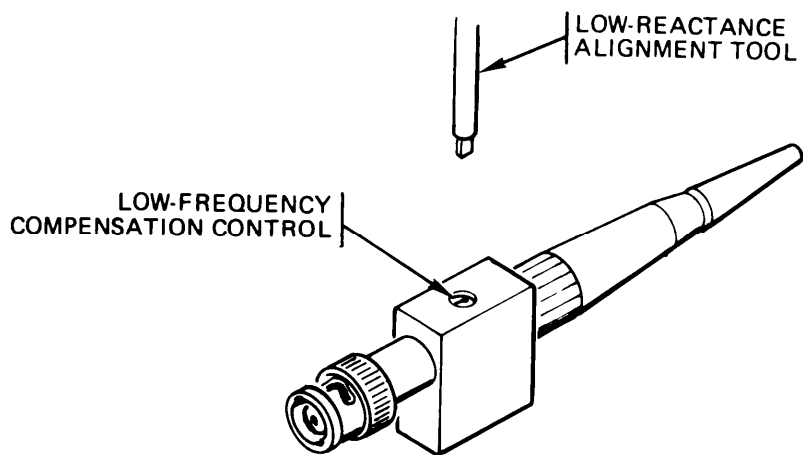

EL9V013

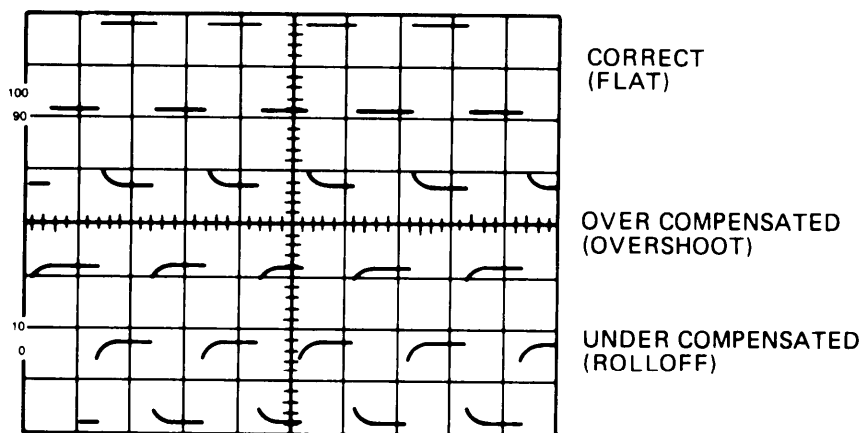

EL9V014

10. Set VERTICAL MODE CH 1/BOTH/CH 2 switch (7) to CH2.
11. Insert tip of channel 2 probe into AMP CAL connector and adjust CH 2 VOLTS/DIV variable control (12) to obtain display amplitude of five vertical divisions.
12. Set A SEC/DIV switch (10) to display five cycles of AMP CAL signal.
13. Using channel 2 vertical POSITION control (13), vertically center display on crt screen.
14. Using low-reactance alignment tool, adjust low-frequency compensation control on probe compensation box to obtain best waveform with flattest top.
15. Probes are now properly compensated.

**c. Peak-To-Peak Voltage Measurements.**

1. Obtain baseline trace as described in para 2-3a.
2. Apply ac signal to either CH 1 OR X connector (1) or CH 2 OR Y connector (2) and set VERTICAL MODE CH 1/BOTH/CH 2 switch (3) to display channel used.

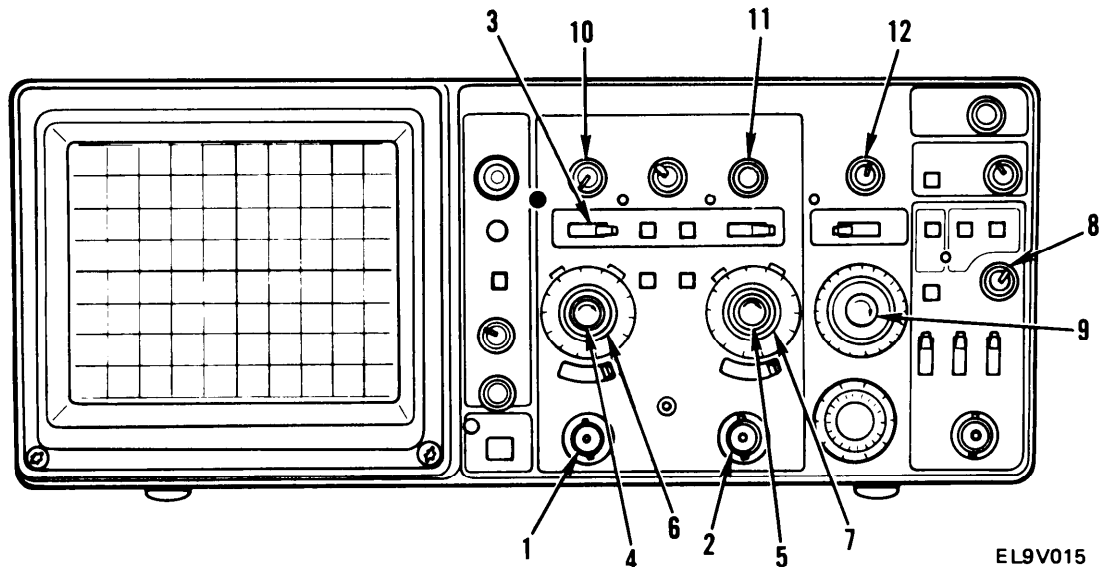

EL9V015

3. Set CH 1 or CH 2 VOLTS/DIV variable control (4 or 5) for appropriate channel to CAL detent position, and set appropriate VOLTS/DIV switch (6 or 7) to display about five vertical divisions of waveform.
4. Adjust A TRIGGER LEVEL control (8) to obtain stable display.
5. Set A SEC/DIV switch (9) to position that allows several cycles of waveform to be displayed.
6. Rotate appropriate vertical POSITION control (10 or 11) until waveform negative peak coincides with one horizontal graticule line.
7. Rotate horizontal POSITION control (12) until one positive peak coincides with center vertical graticule line.

8. Measure deflection from negative point A to positive point B.

**NOTE**

If amplitude measurement is critical or trace is thick because of noise or hum on the signal, a more accurate value can be obtained by measuring from the top of the peak to the top of the valley. This eliminates trace thickness from the measurement.

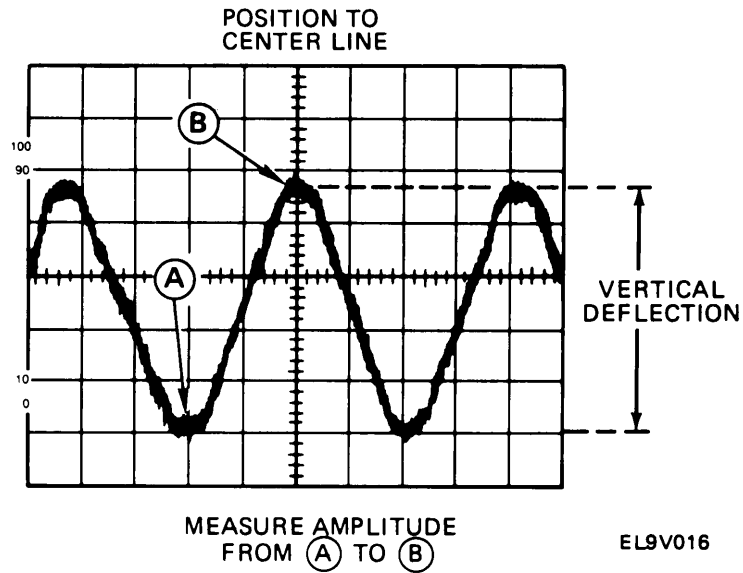

9. Calculate the voltage, using the following formula:

$$\text{volts (p-p)} = \frac{\text{vertical deflection (divisions)}}{\text{VOLTS/DIV switch setting indicated}} \times 1X \text{ (or } 10X \text{ PROBE when } 10X \text{ probe is used)}$$

EXAMPLE: Measured peak-to-peak vertical deflection is 4.6 divisions, a 10X attenuator probe is used and VOLTS/DIV switch is set to 5 at the 10X PROBE setting. Substituting the given values:

$$\text{volts (p-p)} = 4.6 \text{ div} \times 5 \text{ volts/div} = 23 \text{ volts}$$

#### d. Instantaneous Voltage Measurement.

1. Obtain baseline trace as described in para 2-3a.

#### NOTE

This procedure can be used to measure instantaneous voltage for any input waveform. The example shown here is for a square wave.

2. Apply signal to either CH 1 OR X connector (1) or CH 2 OR Y connector (2) and set VERTICAL MODE CH 1 /BOTH/CH 2 switch (3) to display channel used.

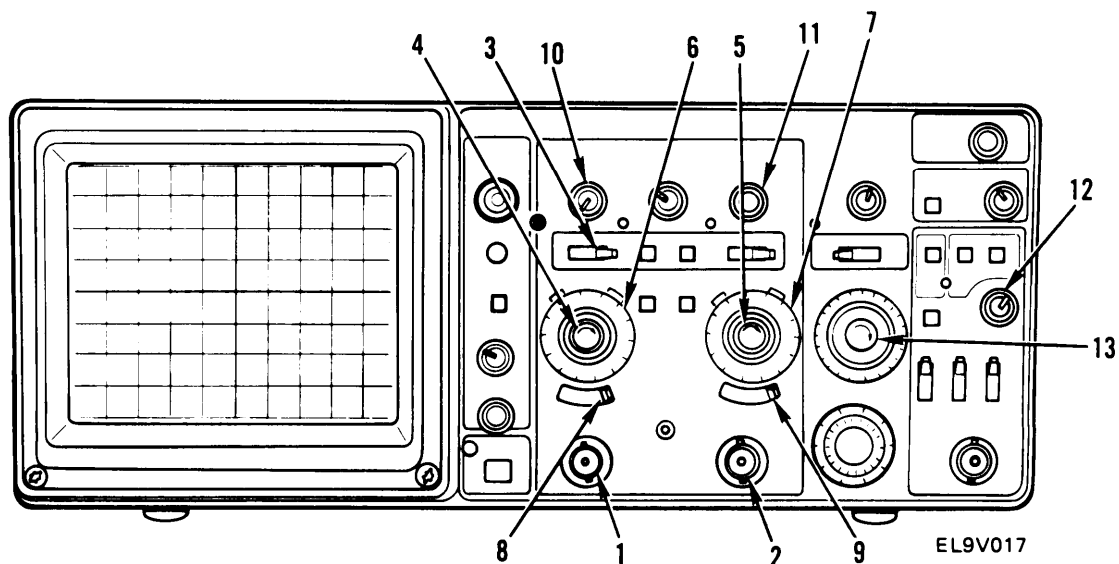

3. Set CH 1 or CH 2 VOLTS/DIV variable control (4 or 5) to CAL detent position, and set appropriate VOLTS/DIV switch (6 or 7) for desired deflection.
4. Set AC/GND/DC switch (8 or 9) to GND.
5. Rotate channel 1 or channel 2 vertical POSITION control (10 or 11) until baseline trace falls on center horizontal graticule line. This establishes ground reference location.
6. Set AC/GND/DC switch (8 or 9) to DC. Points on waveform above ground reference are positive; those below are negative.
7. If necessary, repeat step 5 using different reference line which allows waveform obtained in step 6 to be displayed on crt screen.

8. If using channel 2, ensure that channel 2 vertical POSITION control (11) is pushed in.
9. Adjust A TRIGGER LEVEL control (12) to obtain stable display.
10. Set A SEC/DIV switch (13) to position that allows several cycles of waveform to be displayed.

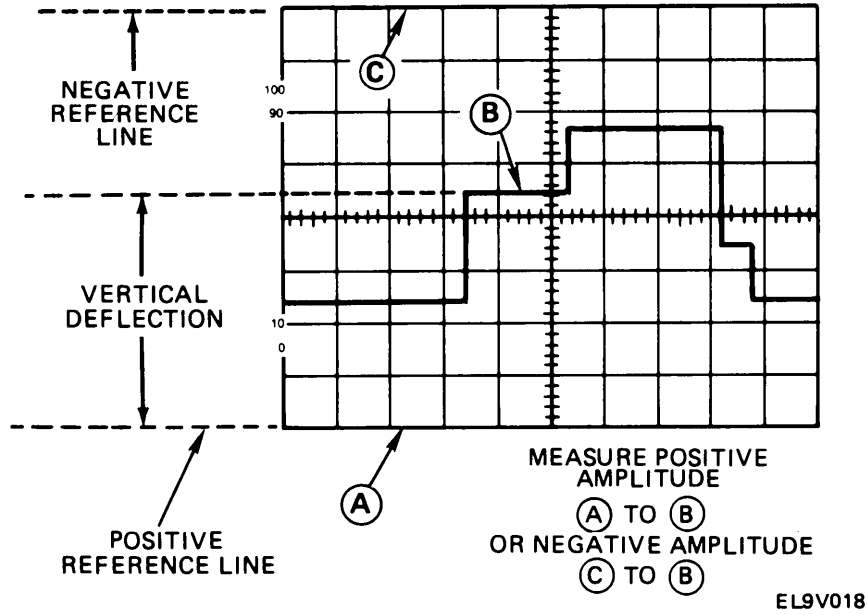

11. Count number of divisions of vertical deflection between ground reference line and point on waveform at which voltage level is to be determined.
12. Calculate voltage using formula:

$$\text{instantaneous voltage} = \text{Vertical deflection (divisions)} \times \text{polarity (+ or --)} \times \text{VOLTS/DIV switch setting indicated by 1X (or 10X PROBE when 10X probe is used)}$$

EXAMPLE: Vertical deflection from reference line is 4.6 divisions. The waveform point is above the reference line, a 10X attenuator probe is used, and VOLTS/ DIV switch is set to 2 at the 10X PROBE position. Substituting given values:

$$\text{instantaneous voltage} = 4.6 \text{ div} \times (+1) \times 2 \text{ volts/div} = +9.2 \text{ volts}$$

**e. Algebraic Addition.**

1. Obtain baseline trace as described in para 2-3a.
2. Set VERTICAL MODE CH 1/BOTH/CH 2 switch (1) to BOTH.
3. Set VERTICAL MODE ALT/ADD/CHOP switch (2) to ADD.

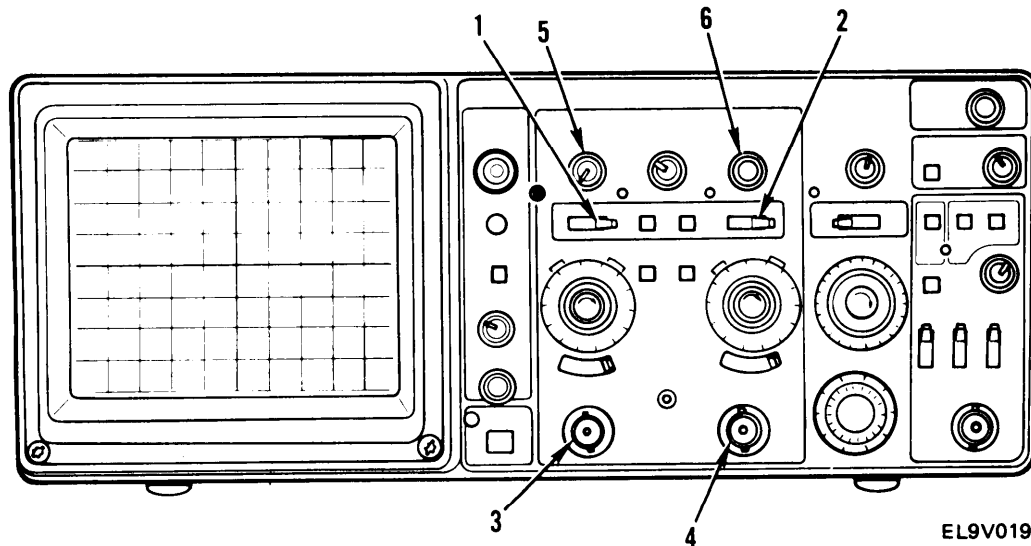

**CAUTION**

Do not exceed maximum safe input voltage rating (para 1-13).

**NOTES**

- Signals that exceed about eight times the VOLTS/DIV switch settings may distort the display.
- To obtain similar response from each  , both AC/GND/DC switches must be set to the same position.

4. Connect one signal to CH 1 OR X connector (3) and one signal to CH 2 OR Y connector (4).

5. Set VERTICAL MODE CH 1/BOTH/CH 2 switch (1) to CH 1 and adjust channel 1 vertical POSITION control (5) to center display vertically on crt screen.
6. Set VERTICAL MODE CH 1/BOTH CH 2 switch (1) to CH 2 and adjust channel 2 vertical POSITION control (6) to center display vertically on crt screen.
7. Set VERTICAL MODE CH 1/BOTH/CH 2 switch (1) to BOTH.

**NOTES**

- If the channel 2 vertical POSITION control is pushed in, the resultant waveform is the sum of the two applied signals.
- If the channel 2 vertical POSITION control is pulled out, the resultant waveform is the difference between the two signals.

### f. Common-Mode Rejection.

1. Obtain baseline trace as described in para 2-3a.

#### NOTE

This procedure can be used to measure instantaneous voltage for any input waveform. The example shown here is for a square wave.

2. Connect signal containing unwanted line-frequency components to CH 1 OR X connector (1).
3. Connect line-frequency signal to CH 2 OR Y connector (2).

#### NOTE

For maximum cancellation, the signal connected to channel 2 must be in phase with the unwanted line-frequency component connected to channel 1.

4. Set VERTICAL MODE CH 1/BOTH/CH 2 switch (3) to BOTH.
5. Set VERTICAL MODE ADD/ALT/CHOP switch (4) to ALT.
6. Set both CH 1 and CH 2 VOLTS/DIV switches (5 and 6) to produce displays four or five divisions in amplitude.
7. Adjust either CH 1 or CH 2 VOLTS/DIV switch (5 or 6) and appropriate VOLTS/DIV variable control (7 or 8) so that both displays are of equal amplitude.

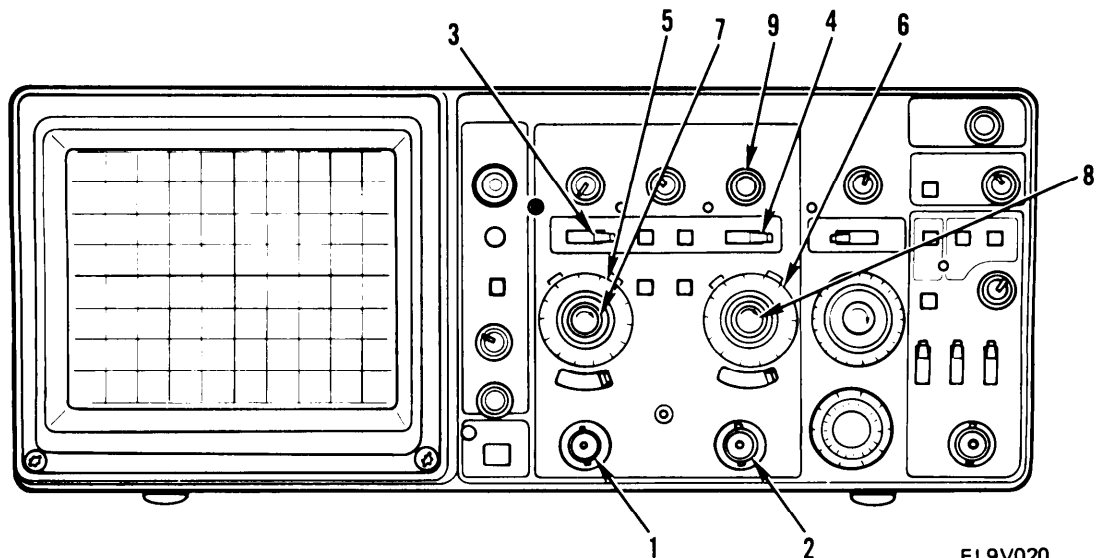

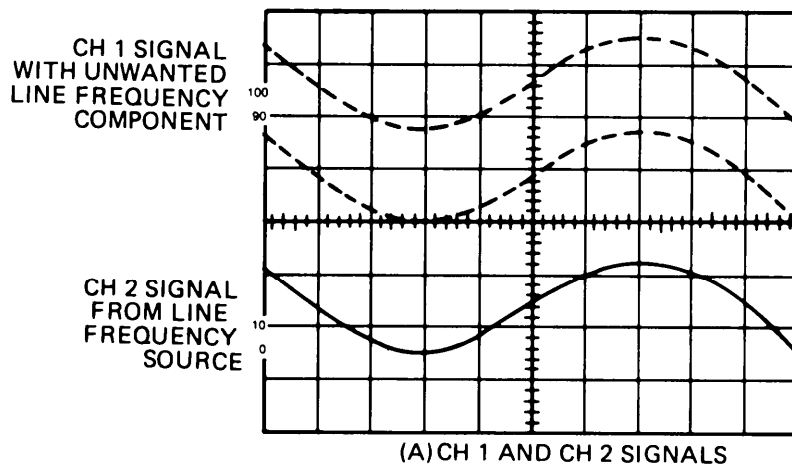

EL9V021

8. Adjust CH 2 VOLTS/DIV switch (6) and CH 2 VOLTS/DIV variable control (8) so that channel 2 display amplitude is approximately same amplitude as undesired portion of channel 1 display.
9. Set VERTICAL MODE ADD/ALT/CHOP switch (4) to ADD.
10. Pull out channel 2 vertical POSITION control (9) to invert signal.
11. Slightly readjust CH 2 VOLTS/DIV variable control (8) for maximum cancellation of unwanted signal.

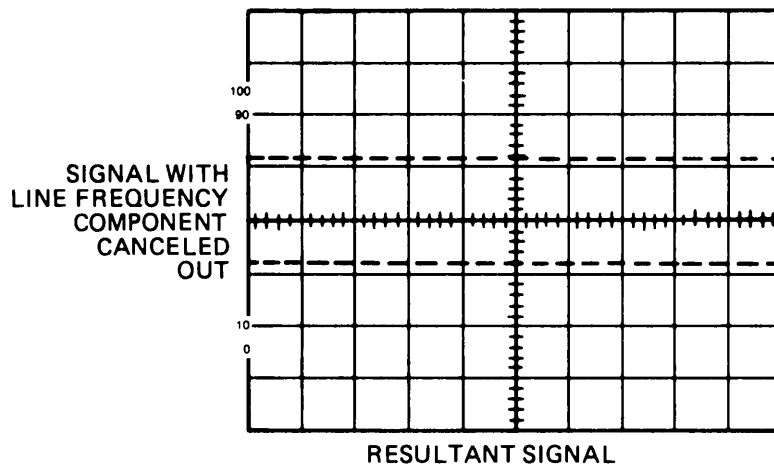

EL9V022

**g. Amplitude Comparison (Ratio).**

1. Obtain baseline trace as described in para 2-3a.
2. Connect known reference signal to either CH 1 OR X connector (1) or CH 2 OR Y connector (2).
3. Set VERTICAL MODE CH 1/BOTH/CH 2 switch (3) to channel to which reference signal is connected.

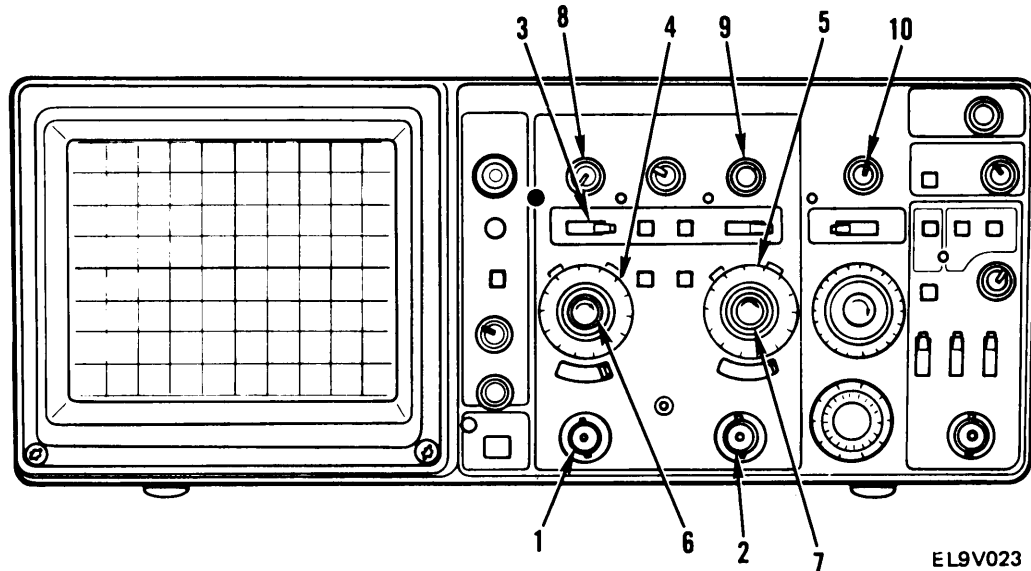

4. Adjust CH 1 or CH 2 VOLTS/DIV switch (4 or 5) and appropriate VOLTS/DIV variable control (6 or 7) for display amplitude of five vertical divisions.
5. Disconnect reference signal connected in step 2 and connect unknown signal to same connector.
6. Rotate channel 1 or 2 vertical POSITION control (8 or 9) until bottom edge of waveform just touches 0% line on crt.
7. Rotate horizontal POSITION control (10) until topmost feature of waveform crosses center vertical graticule line.

8. Read percent ratio directly from graduations of center vertical graticule line, referring to 0% and 100% marks on left edge of graticule. (One minor division equals 4% for five-division display.)

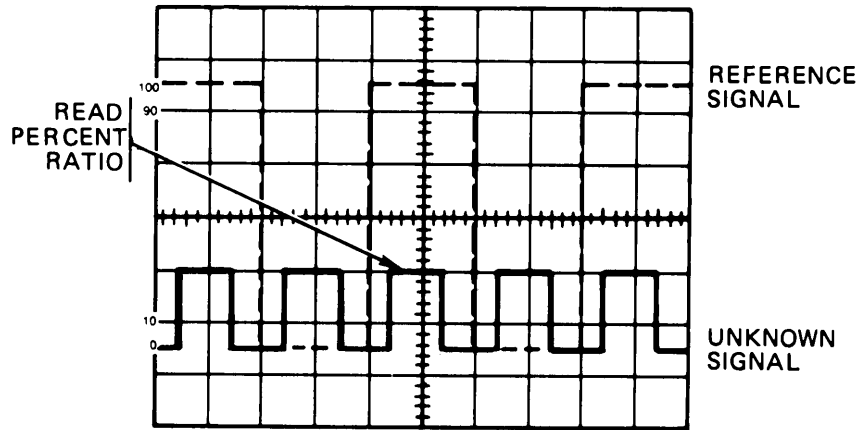

EL9V024

### h. Time Duration Measurement.

1. Obtain baseline trace as described in para 2-3a.

#### NOTE

This procedure can be used to measure instantaneous voltage for any input waveform. The example shown here is for a square wave.

2. Connect signal to either CH 1 OR X connector (1) or CH 2 OR Y connector (2).
3. Set VERTICAL MODE CH 1/BOTH/CH 2 switch (3) to appropriate channel.

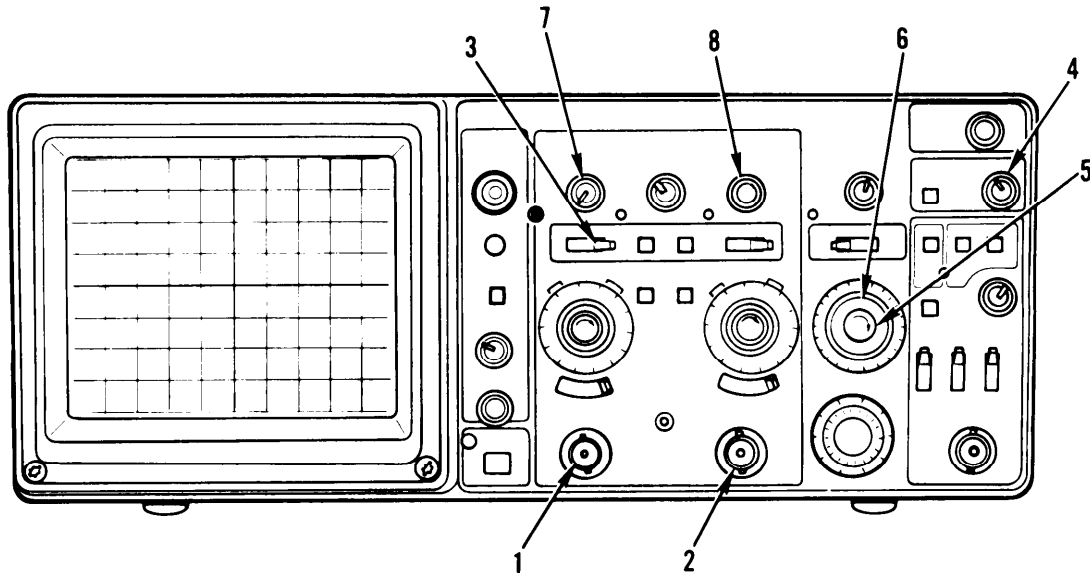

EL9V025

4. Adjust A TRIGGER LEVEL control (4) to obtain stable display.
5. Set A and B SEC/DIV variable control (5) to CAL detent, and set A SEC/DIV switch (6) to display one complete cycle of waveform.
6. Rotate channel 1 or channel 2 vertical POSITION control (7 or 8) until time measurement points fall on center horizontal graticule.
7. Count horizontal divisions between time measurement points.

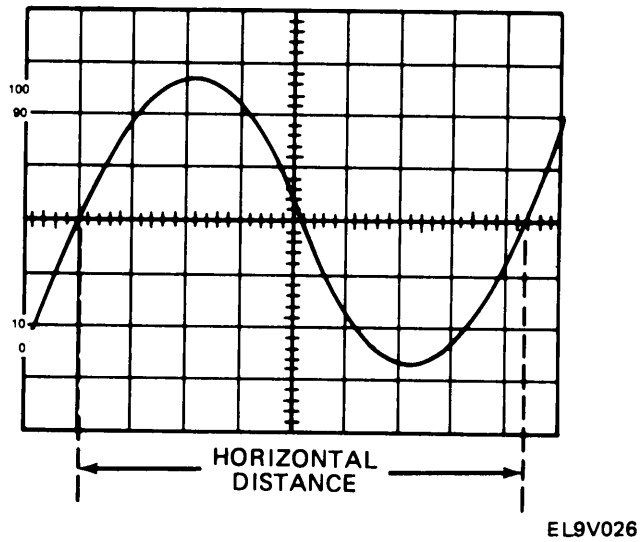

8. Calculate time duration using formula:

$$\text{duration} = \frac{\text{horizontal distance (division)} \times \text{A SEC/DIV switch setting}}{\text{magnification factor}}$$

EXAMPLE: The distance between time measurement points is 8.3 divisions. The A SEC/DIV switch is set to 2 ms per division, and the X 10 multiplier is off. Substituting given values:

$$\text{time duration} = \frac{8.3 \text{ div} \times 2 \text{ ms/div}}{1} = 16.6 \text{ ms}$$

**i. Frequency Measurement.**

1. Measure time duration of one cycle of waveform as described in paragraph 2-3h.
2. Calculate reciprocal of time duration determined in step 2-3h(8) to determine frequency of waveform.

EXAMPLE: The signal obtained has a time duration of 16.6 ms. Substituting given values:

$$\text{frequency} = \frac{1}{\text{time duration}} = \frac{1}{16.6 \text{ ms}} \approx 60 \text{ Hz}$$

**j. Rise Time Measurement.**

1. Obtain baseline trace as described in paragraph 2-3a.
2. Set BW LIMIT switch (1) to off (pushbutton out).
3. Connect signal to either CH 1 OR X connector (2) or CH 2 OR Y connector (3).
4. Set VERTICAL MODE CH 1/BOTH/CH 2 switch (4) to appropriate channel.
5. Set appropriate CH 1 or CH 2 VOLTS/DIV switch (5 or 6) and VOLTS/DIV variable control (7 or 8) for an exact five-division display.

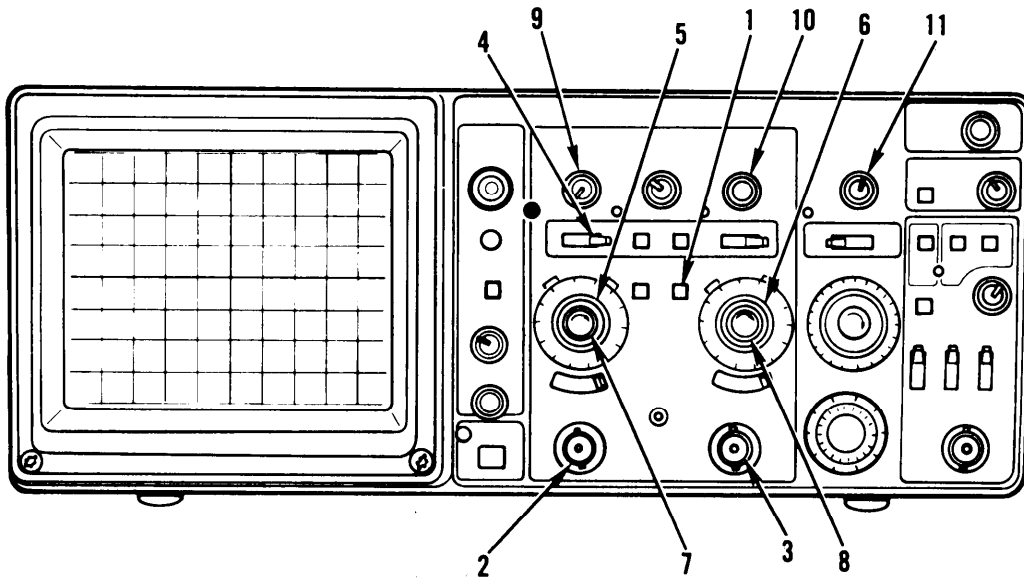

EL9V027

6. Rotate channel 1 or channel 2 vertical POSITION control (9 or 10) until zero reference of waveform touches 0% graticule and top of waveform touches 100% graticule,
7. Rotate horizontal POSITION control (11) until 10% point on waveform intersects second vertical graticule line.

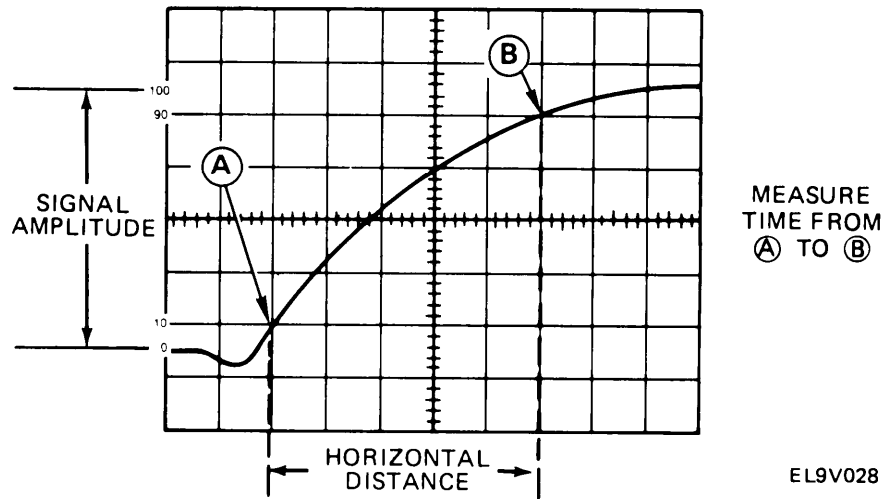

8. Determine horizontal distance between 10% and 90% points (points A and B) and calculate time duration using formula:

$$\text{rise time} = \frac{\text{horizontal distance (division)} \times \text{A SEC/DIV switch setting}}{\text{magnification factor}}$$

EXAMPLE: The horizontal distance between the 10% and 90% points is five divisions, The A SEC/DIV switch setting is 1 us and the magnification factor is 1. Substituting the given values:

$$\text{rise time} = \frac{5 \text{ div} \times 1 \text{ us/div}}{1} = 5 \text{ us}$$

**k. Rise Time Measurement in Delayed-Sweep Mode.**

1. Obtain baseline trace as described in para 2-3a.
2. Connect signal to either CH 1 OR X connector (1) or CH 2 OR Y connector (2).
3. Set VERTICAL MODE CH 1 /BOTH/CH 2 switch (3) to selected channel.
4. Set appropriate CH 1 or CH 2 VOLTS/DIV switch (4 or 5) and VOLTS, DIV variable control (6 or 7) to provide display amplitude of exactly five divisions.
5. Rotate appropriate channel 1 or 2 vertical POSITION control (8 or 9) until zero reference line of waveform touches 0% graticule line and top of waveform touches 100% graticule line.
6. Set SEC/DIV variable control (10) to CAL detent position and set A SEC/DIV switch (11) so one rise time of interest is displayed.
7. Set HORIZONTAL MODE switch (12) to ALT.
8. Adjust B DELAY TIME POSITION control (13) to intensify rise time of interest on A trace.

9. Set B SEC/DIV switch (11) so portion of A trace being measured is spread as much as possible on B sweep.
10. Set HORIZONTAL MODE switch (12) to B.
11. Adjust B DELAY TIME POSITION control (13) until display intersects 10% point at center vertical graticule line. Record B DELAY TIME POSITION control dial reading.

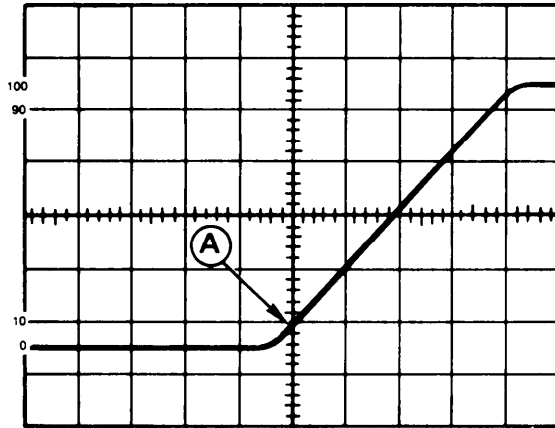

THE 10% POINT ON THE WAVEFORM INTERSECTS THE CENTER VERTICAL GRATICULE LINE.

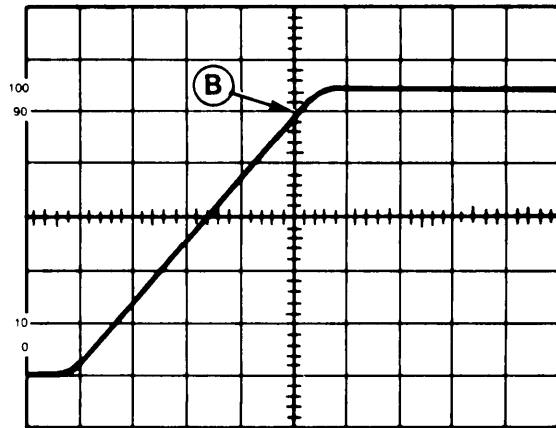

THE 90% POINT ON THE WAVEFORM INTERSECTS THE CENTER VERTICAL GRATICULE LINE.

EL9V043

12. Adjust B DELAY TIME POSITION control (13) until display intersects the 90% point at center vertical graticule line. Record B DELAY TIME POSITION control dial reading.
13. Calculate rise time using the formula:

$$\text{time difference (duration)} = \frac{\text{second dial setting} - \text{first dial setting}}{\text{A SEC/DIV switch setting}}$$

EXAMPLE: A SEC/ DIV switch is set to 1 us per division, first B DELAY TIME POSITION control is set to 2.50, and second B DELAY TIME POSITION control is set to 7.50. Substituting given values:

$$\text{rise time} = (7.03 - 2.50)(1 \text{ us/div}) = 5 \text{ us}$$

**1. Phase Difference Measurement.**

1. Obtain baseline trace as described in para 2-3a.
2. Depress CH 1 TRIGGER SOURCE switch (1).
3. Set both AC/GND/DC switches (2 and 3) to desired positions and ensure that both are set to same position.
4. Using either probes or cables with equal time delays, connect known reference signal to CH 1 OR X connector (4) and comparison signal to CH 2 OR Y connector (5).
5. Set both CH 1 and CH 2 VOLTS/DIV switches (6 and 7) for four- or five-division display.
6. Set VERTICAL MODE CH 1/BOTH/CH 2 switch (8) to BOTH.
7. Set VERTICAL MODE ADD/ALT/CHOP switch (9) to either ALT or CHOP, depending on frequency of input signals.

**NOTE**

The reference signal should precede the comparison signal in time.

8. If two signals are opposite polarities, pull out channel 2 vertical POSITION control (10) to invert channel 2 display.

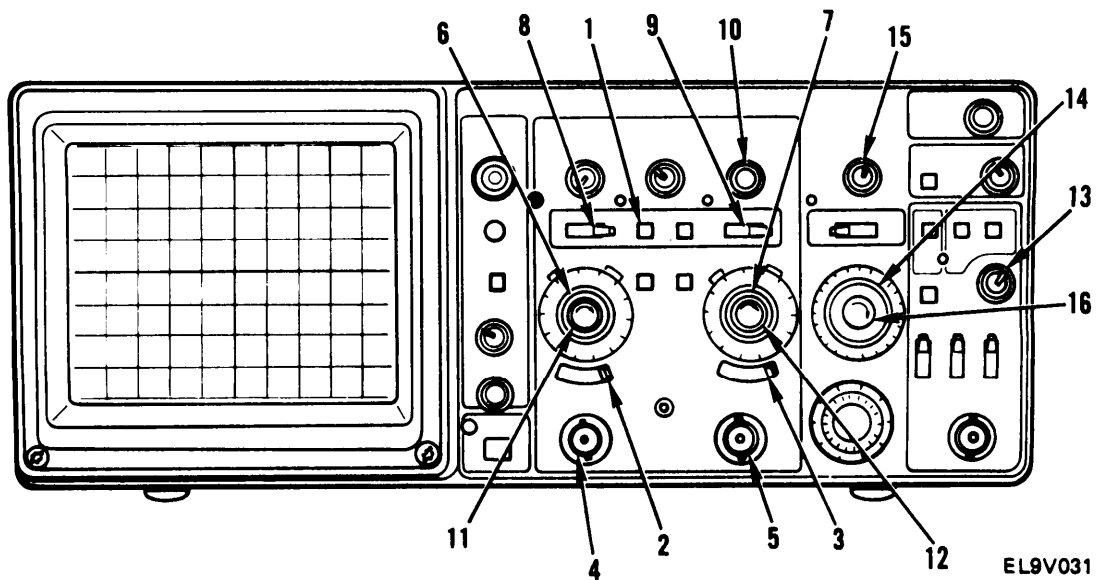

9. Adjust both CH 1 and CH 2 VOLTS/DIV variable controls (1 1 and 12) until two displays are equal in amplitude.
10. Adjust A TRIGGER LEVEL control (13) for stable display.
11. Set A SEC/DIV switch (14) to sweep speed setting which provides display of one full cycle of reference signal.
12. Using horizontal POSITION control (15), center display.
13. Adjust SEC/DIV variable control (16) until one reference signal cycle occupies exactly eight horizontal graticule divisions at 50% rise-time points. Each graticule division now represents 45° and graticule calibration can be stated as 45° per division.

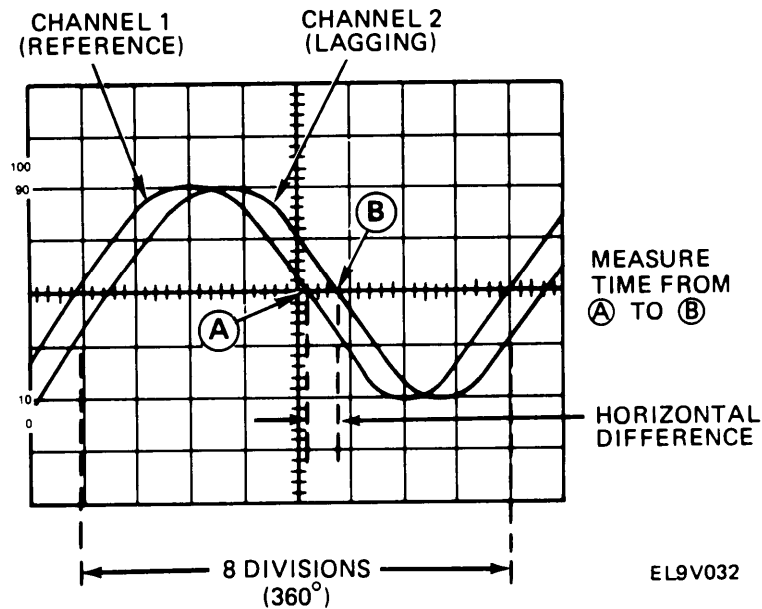

14. Determine horizontal difference between corresponding points on waveforms at common horizontal graticule line and calculate phase difference using formula:

$$\text{phase difference} = \frac{\text{horizontal difference}}{\text{divisions}} \times \frac{\text{horizontal calibration}}{\text{deg/div}}$$

EXAMPLE: The horizontal difference is 0.6 division with a graticule calibration of 45° per division. Substituting given values:

$$\text{Phase difference} = 0.6 \text{ div} \times 45^\circ / \text{div} = 27^\circ$$

**m. Magnified B Sweep Runs After Delay.**

1. Obtain baseline trace as described in para 2-3a.
2. Connect signal to either CH 1 OR X connector (1) or CH 2 OR Y connector (2).
3. Set VERTICAL MODE CH 1/BOTH/ CH 2 switch (3) to selected channel.

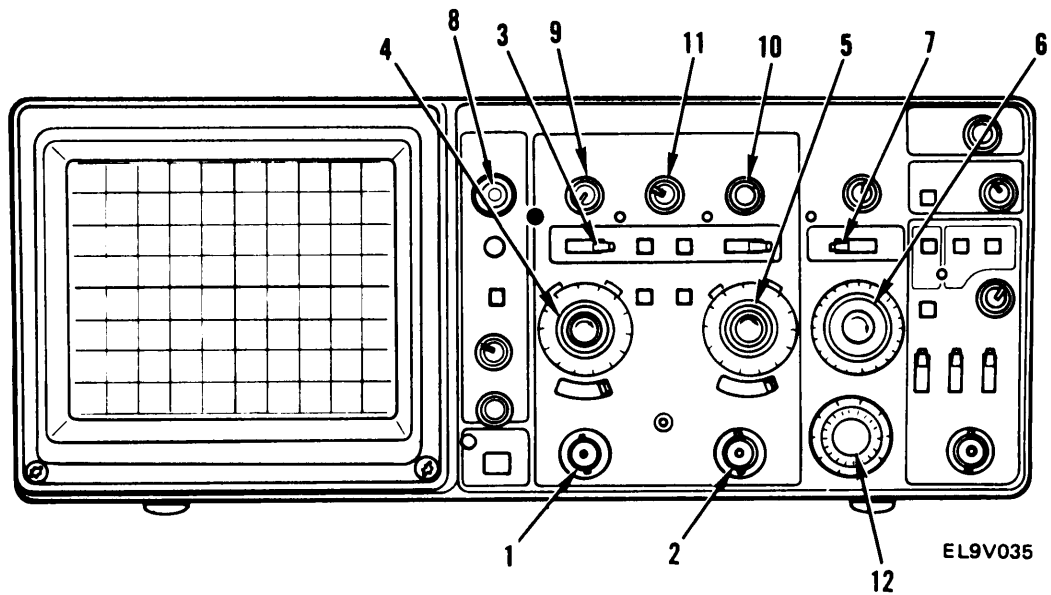

4. Set appropriate CH 1 or CH 2 VOLTS/DIV switch (4 or 5) to provide display amplitude of two or three divisions.
5. Set A SEC/DIV switch (6) to sweep speed setting which provides display of at least one complete waveform cycle.
6. Set HORIZONTAL MODE switch (7) to ALT.
- 7.- Adjust B INTENSITY control (8) to display B trace.
8. Adjust appropriate vertical POSITION control (9 or 10) and A/BSWP SEP control (11) to display A trace above B trace.
9. Adjust B DELAY TIME POSITION control ( 12) to position start of intensified zone to portion of display to be magnified.
10. Set B SEC/DIV switch (6) to setting which intensifies full portion of A trace to be magnified. Intensified zone is displayed as B trace.

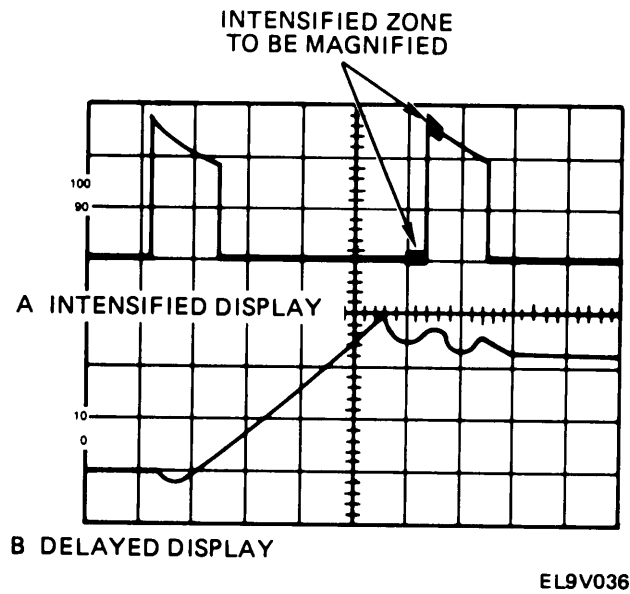

EL9V036

11. Calculate apparent sweep magnification using formula:

$$\text{apparent delayed sweep magnification} = \frac{\text{A SEC/DIV switch setting}}{\text{B SEC/DIV switch setting}}$$

EXAMPLE: Determine the apparent delayed sweep magnification of a display with an A SEC/DIV switch setting of 0.1 ms per division and a B SEC/DIV switch setting of 1 us per division. Substituting the given values:

$$\text{apparent delayed sweep magnification} = \frac{1 \times 10^{-4}}{1 \times 10^{-6}} = 10^2 = 100$$

n. **Pulse Jitter Time Measurement.**

1. Perform Magnified Sweep Runs After Delay, para 2-3m, steps 1 through 10.
2. Determine number of divisions difference between points C and D and calculate pulse jitter time using formula:

$$\text{pulse jitter time} = \text{horizontal difference (divisions)} \times \text{B SEC/ DIV switch setting}$$

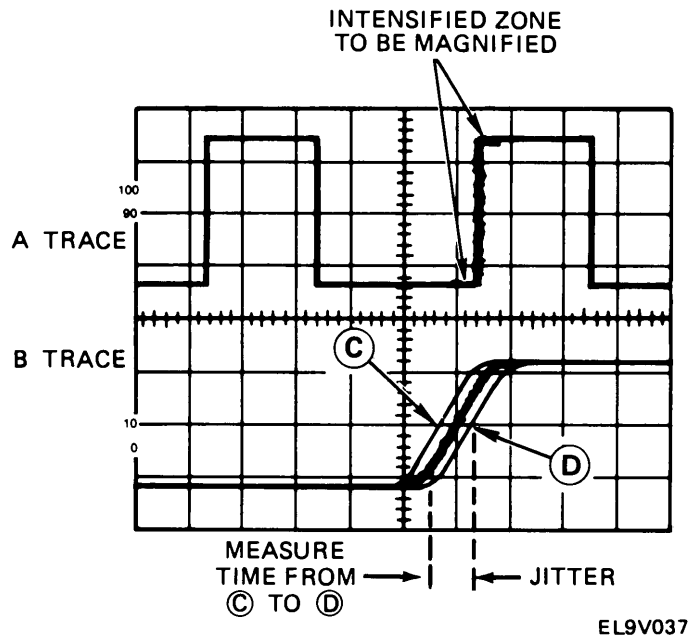

p. Triggered Magnified Sweep Measurement.

1. Perform Magnified Sweep Runs After Delay, para 2-3m, steps 1 through 10.

**NOTE**

The intensified zone seen in the ALT HORIZONTAL MODE display will move from trigger point to trigger point as B DELAY TIME POSITION CONTROL is rotated.

2. Adjust B TRIGGER LEVEL control (1) to stabilize intensified portion of A trace.
3. Calculate apparent magnification factor using formula:

$$\text{apparent magnification factor} = \frac{\text{A SEC/DIV switch setting}}{\text{B SEC/DIV switch setting}}$$

EXAMPLE: Determine apparent magnification factor of a display with an A SEC/DIV switch setting of 0.1 ms per division and a B SEC/DIV switch setting of 1 us per division. Substituting given values:

$$\text{apparent magnification factor} = \frac{1 \times 10^{-4}}{1 \times 10^{-6}} = 10^2 = 100$$

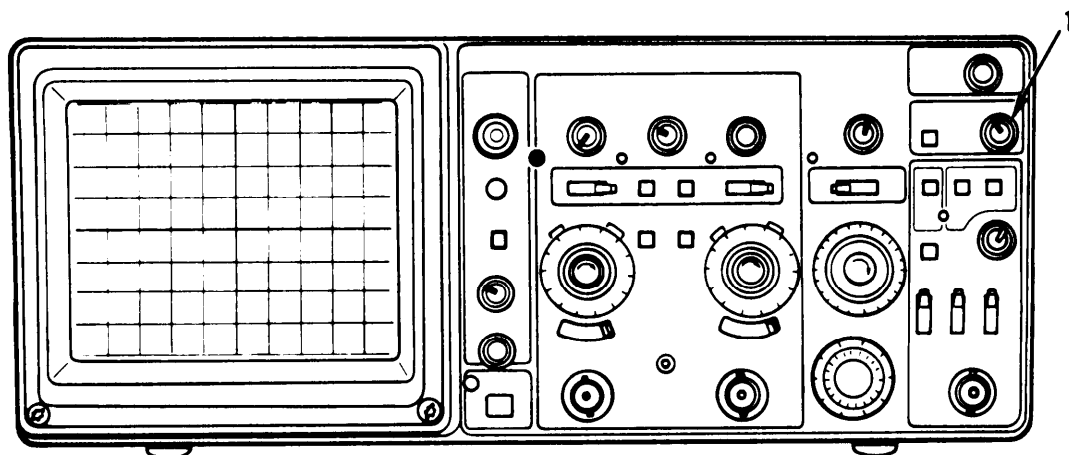

EL9V038

q. Time Difference Measurement on

1. Obtain baseline trace as described in para 2-3a.
2. Connect signal to either CH 1 OR X connector (1) or CH 2 OR Y connector (2).
3. Set VERTICAL MODE CH 1/ BOTH/ CH 2 switch (3) to selected channel.
4. Set appropriate CH 1 or CH 2 VOLTS/ DIV switch (4 or 5) to provide display amplitude of two or three divisions.

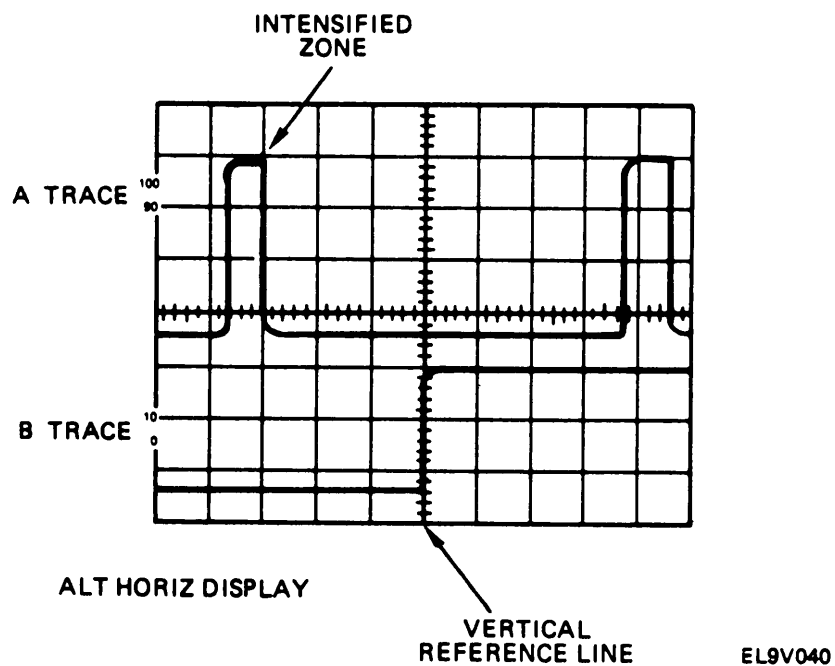
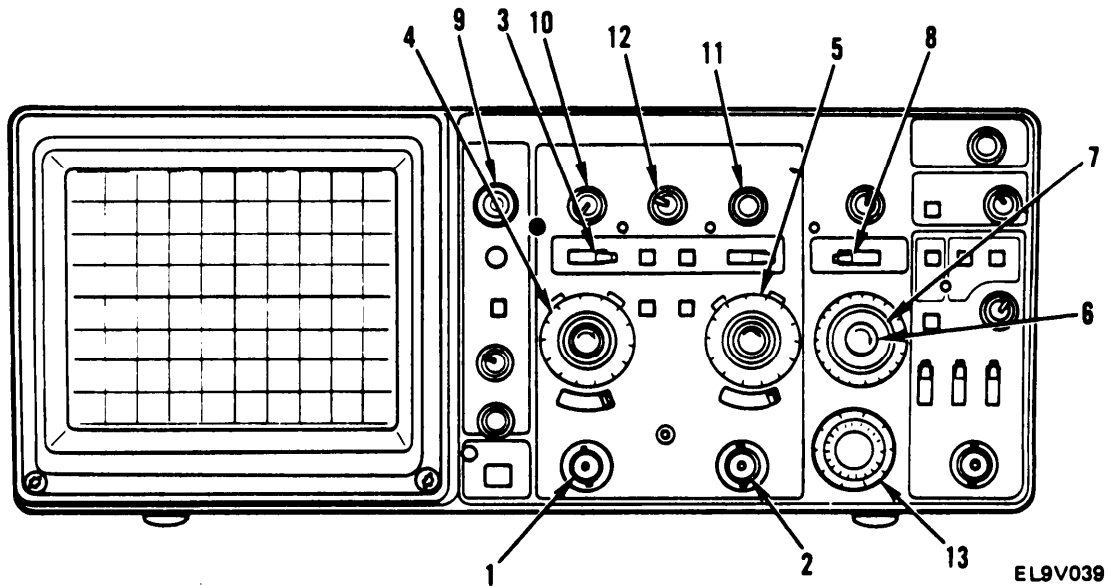

5. Ensure that SEC/DIV variable control (6) is in CAL detent position and set A SEC/DIV Switch (7) to sweep speed setting that displays measurement points on waveform.
6. Set HORIZONTAL MODE switch (8) to ALT.
7. Adjust B INTENSITY control (9) to display trace.
8. Adjust appropriate channel 1 or 2 vertical POSITION control (10 or 11) and A/B SWP SEP control ( 12) to display A trace above B trace.
9. Set B SEC/DIV control (7) to fastest sweep speed that provides visible intensified zone.
10. Adjust B DELAY TIME POSITION control (13) to move intensified zone to leading edge of first point of interest on A trace; then fine adjust until selected portion on B trace is centered on any vertical graticule line. Record B DELAY POSITION control reading.
11. Adjust B DELAY TIME POSITION control clockwise to move intensified zone to leading edge of second point of interest on A trace, then fine adjust until rising portion on B trace is centered at same vertical graticule used in step (10). Record B DELAY TIME POSITION control (13) dial reading.

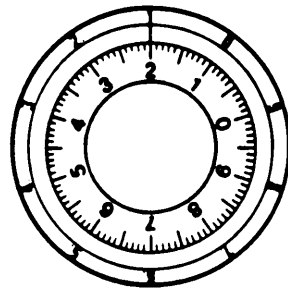

DIAL READING AT POINT A

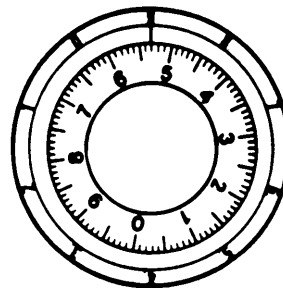

DIAL READING AT POINT B

EL9V041

12. Calculate time difference between repetitive pulses using formula

$$\text{time difference (duration)} = \text{second dial setting} - \text{first dial setting} \times \text{A SEC/DIV switch setting}$$

EXAMPLE: A SEC/DIV switch is set to 0.2 ms per division, first B DELAY TIME POSITION control is set to 1.20, and second B DELAY TIME POSITION control is set to 9.53. Substituting given values:

$$\text{Time difference} = (9.53 - 1.20)(0.2 \text{ ms/div}) = 1.666 \text{ ms}$$

**r. Measurement of Time Difference Between Pulses on Time-Related Signals.**

1. Obtain baseline trace as described in para 2-3a.
2. Depress CH 1 TRIGGER SOURCE switch (1).
3. Set both AC/ GND/ DC switches (2 and 3) to desired position and ensure that both are set to same position.
4. Using either probes or cables with equal time delays, connect known reference signal to CH 1 OR X connector (4) and comparison signal to CH 2 OR Y connector (5).
5. Set both CH 1 and CH 2 VOLTS/ DIV switches (6 and 7) for four- or five-division display.
6. Set VERTICAL MODE CH 1/BOTH/CH 2 switch (8) to BOTH.
7. Set VERTICAL MODE ADD/ALT/ CHOP switch (9) to either ALT or CHOP, depending on frequency of input signals.
8. If two signals are opposite polarities, pull out channel 2 vertical POSITION control (10) to invert channel 2 display.

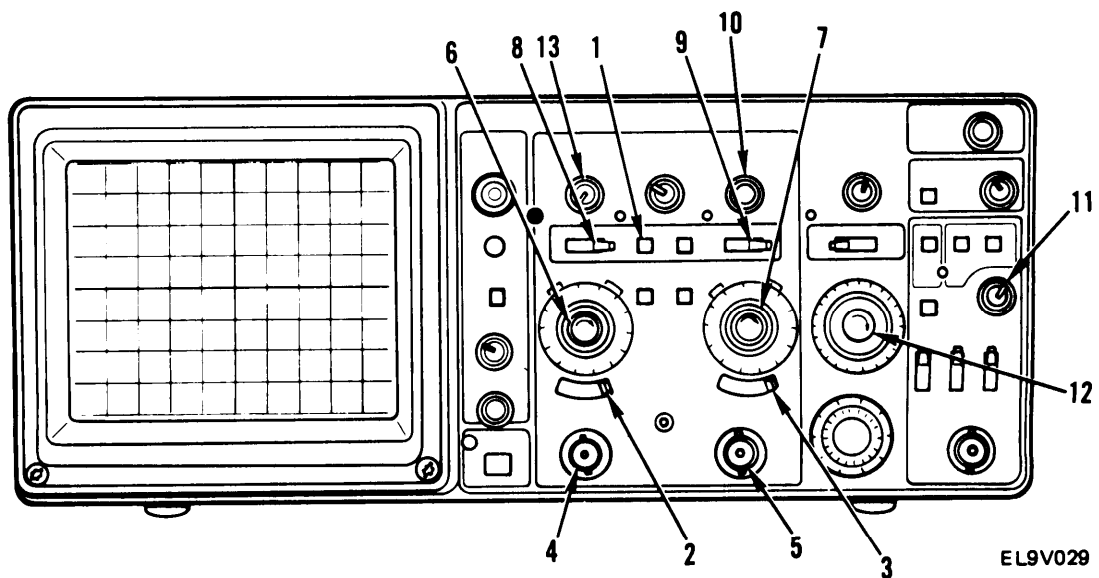

9. Adjust A TRIGGER LEVEL control (11) for stable display.
10. Set A SEC/DIV switch (12) to sweep speed setting which provides three or more divisions of horizontal separation between reference points on two displays.
11. Rotate both vertical POSITION controls (10 and 13) to vertically center both displays.
12. Determine horizontal distance between two signal reference points and calculate time difference using formula:

$$\text{time difference} = \frac{\text{A SEC/DIV switch setting} \times \text{horizontal difference (divisions)}}{\text{magnification factor}}$$

EXAMPLE: The A SEC/DIV switch is set to 50 us per division, the X10 magnifier is on (button out), and horizontal difference between signal measurement points is 4.5 divisions. Substituting the given values:

$$\text{time difference} = \frac{50 \text{ us/div} \times 4.5 \text{ div}}{10} = 22.5 \text{ us}$$

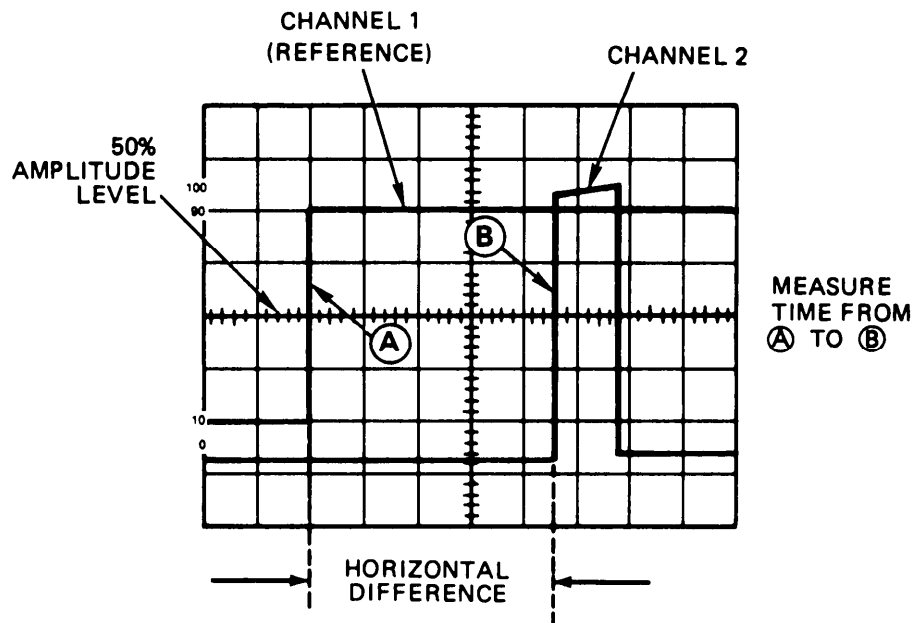

EL9V030

**s. Time Difference Measurement Between Two Pulses on Two Time-Related Signals in Delayed Sweep Mode.**

1. Obtain baseline trace as described in para 2-3a.
2. Depress CH 1 TRIGGER SOURCE switch (1).
3. Set VERTICAL MODE CH 1/BOTH/ CH 2 switch (2) to BOTH.
4. Set VERTICAL MODE ADD/ ALT/ CHOP switch (3) to ALT.

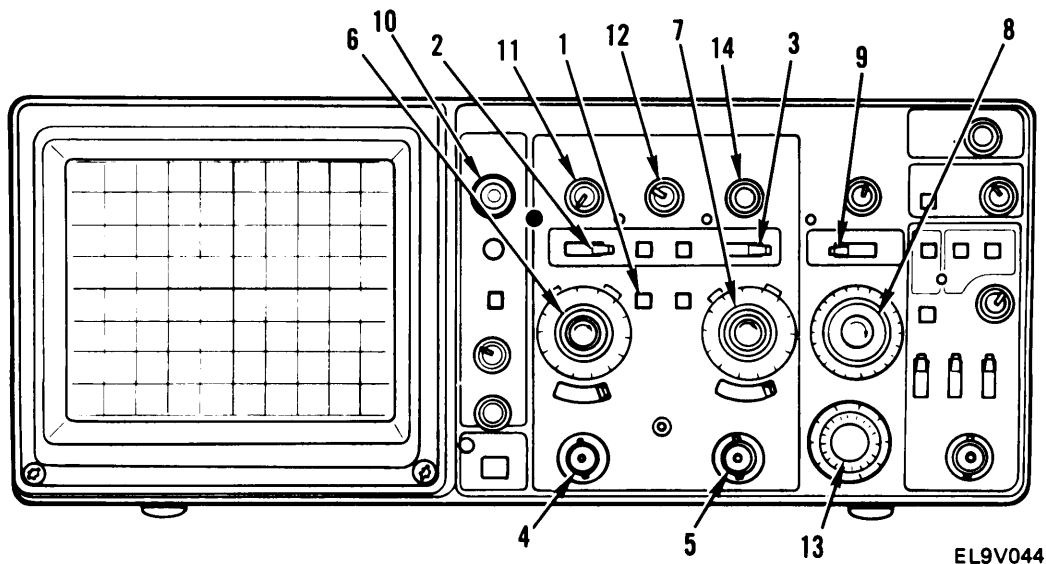

5. Using either probes or cables with equal time delays, connect known reference signal to CH 1 OR X connector (4) and comparison signal to CH 2 OR Y connector (5).
6. Set both CH 1 and CH 2 VOLTS/DIV switches (6 and 7) for two- or three-division display.
7. Set A SEC/DIV switch (8) to display measurement points within graticule area.
8. Set HORIZONTAL MODE switch (9) to ALT.
9. Set VERTICAL MODE CH 1/BOTH/CH 2 switch (2) to CH 1.

10. Adjust B INTENSITY control (10) to display trace.
11. Adjust channel 1 vertical POSITION control (11) and A/B SWP SEP control (12) to display A trace above B trace,
12. Rotate B DELAY TIME POSITION control ( 13) to move intensified zone to appropriate edge of comparison signal on A trace, then fine adjust until edge of reference signal on B trace is centered at any convenient vertical graticule line. Record B DELAY TIME POSITION control dial reading.
13. Set VERTICAL MODE CH 1 /BOTH/CH 2 switch (2) to CH 2.
14. Adjust channel 2 vertical POSITION control (14) and A/B SWP SEP control (12) to display A trace above B trace.
15. Rotate B DELAY TIME POSITION control (13) to move intensified zone to appropriate edge of comparison signal on A trace, then fine adjust until edge of reference signal on B trace is centered on same vertical graticule line used in step 14. Do not move horizontal POSITION control. Record B DELAY TIME POSITION dial reading.

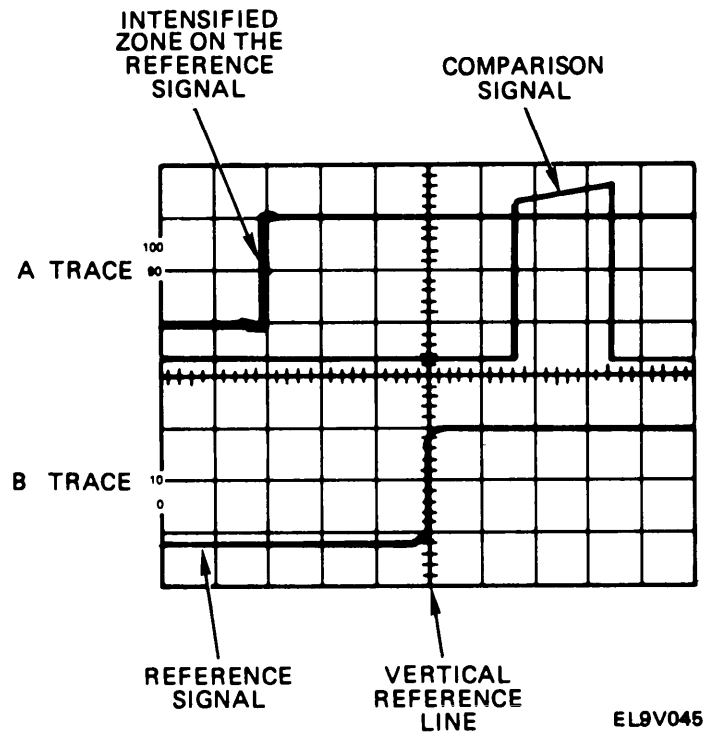

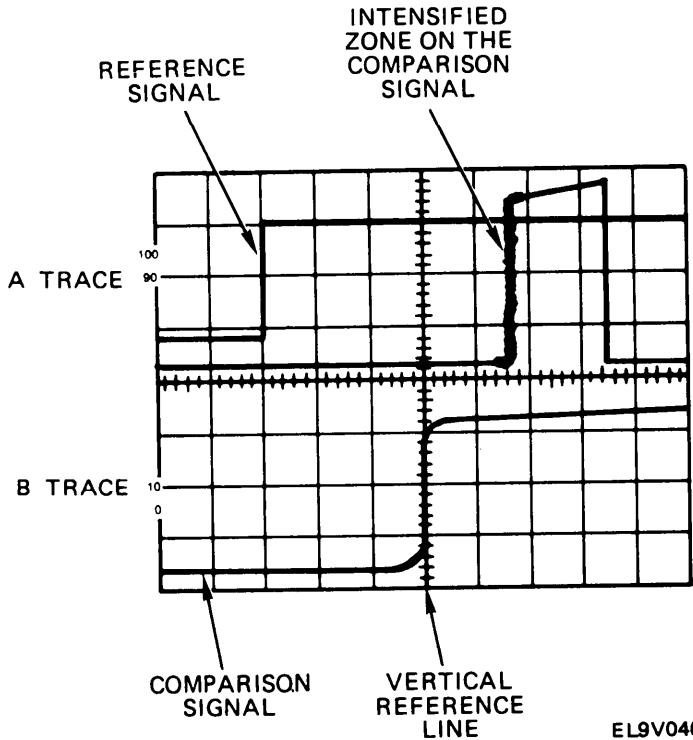

16. Calculate time difference between reference signal and comparison signal using formula:

$$\text{time difference (duration)} = \frac{\text{second dial setting} - \text{first dial setting}}{\text{A SEC/DIV switch setting}}$$

EXAMPLE: A SEC/DIV switch is set to 50 us per division, first B DELAY TIME POSITION control is set to 2.60, and second B DELAY TIME POSITION control is set to 7.10. Substituting given values:

$$\text{time difference} = (7.10 - 2.60)(50 \text{ us/div}) = 225 \text{ us}$$

## Section IV. OPERATION UNDER UNUSUAL CONDITIONS

### 2-4. OPERATION IN UNUSUAL WEATHER

The oscilloscope was designed as a bench-type instrument to be used in a controlled environment. It does not have a weatherproof or waterproof case. It may be used outdoors as long as it is protected from extreme heat, excessive cold, water, sand, mud, or similar conditions. Refer to chapter 1, para 1-13, for oscilloscope specifications that should not be exceeded.

## CHAPTER 3 ORGANIZATIONAL MAINTENANCE

	Para	Page
A and B Intensity Knobs Replacement . . . . .	3-11	3-8
A and B SEC/DIV Knob Replacement . . . . .	3-13	3-10
CH 1 VOLTS/DIV and CH 2 VOLTS/DIV Knob Replacement . . . . .	3-12	3-9
Checking Unpacked Equipment . . . . .	3-5	3-2
Cleaning . . . . .	3-14	3-11
Common Tools and Equipment. . . . .	3-1	3-1
Initial Checks, Adjustments and Tests . . . . .	3-6	3-2
Line Fuse Replacement. . . . .	3-10	3-7
Operational Test. . . . .	3-9	3-5
Preparation for Storage or Shipment. . . . .	3-15	3-12
Repair Parts. . . . .	3-3	3-1
Safety Precautions. . . . .	3-7	3-3
Special Tools, TMDE, and Support Equipment . . . . .	3-2	3-1
Troubleshooting Procedures. . . . .	3-8	3-3
Types of Storage. . . . .	3-16	3-12
Unpacking . . . . .	3-4	3-2

### Section I. REPAIR PARTS, SPECIAL TOOLS; TEST, MEASUREMENT, AND DIAGNOSTIC EQUIPMENT (TMDE); AND SUPPORT EQUIPMENT

#### 3-1. COMMON TOOLS AND EQUIPMENT

Common tools and equipment required for organizational maintenance of Oscilloscope AN/USM-488 are listed in Appendix B (Maintenance Allocation Chart).

#### 3-2. SPECIAL TOOLS, TMDE, AND SUPPORT EQUIPMENT

No special tools, TMDE, or support equipment are required.

#### 3-3. REPAIR PARTS

Repair parts are listed and illustrated in the Repair Parts and Special Tools List (TM 11-6625-3135-24P).

## Section II. SERVICE UPON RECEIPT

### 3-4. UNPACKING

The oscilloscope is shipped assembled in its original packing container. Unpack carefully and do not damage the container while unpacking. Save the container for use in reshipment.

### 3-5. CHECKING UNPACKED EQUIPMENT

- a. Inspect the equipment for damage incurred during shipment. If the equipment has been damaged, report the damage on Form SF 364, Report of Discrepancy.
- b. Check the equipment against the packing slip to see if the shipment is complete. Report all discrepancies in accordance with the instructions of DA Pam 750-8.
- c. Check to see whether the equipment has been modified.

### 3-6. INITIAL CHECKS, ADJUSTMENTS AND TESTS

- a. **Checks.** Check that installed fuse in 1.0 amp, 250 volt, slow-blow.
- b. **Adjustments.** Compensate probes as described in para 2-3b.
- c. **Tests.** Perform complete operational test detailed in para 3-9.

## Section III. TROUBLESHOOTING

### 3-7. SAFETY PRECAUTIONS

#### WARNING

High voltage is used in the operation of this equipment. Death on contact may result if you fail to observe safety precautions.

### 3-8. TROUBLESHOOTING PROCEDURES

The troubleshooting procedures listed in table 3-1 are those that may be done by organizational maintenance level personnel. Problems that may arise during operation are listed under malfunction. Tests or inspections to conduct and corrective actions to take to repair the malfunction are listed in the two columns to the right of the malfunction column.

**Table 3-1. Troubleshooting**

---

<b>Malfunction</b>	<b>Test or inspection</b>	<b>Corrective Action</b>
--------------------	---------------------------	--------------------------

---

1. POWER INDICATOR DOES NOT COME ON.

Step 1. Check that POWER ON/ OFF switch is in (ON).

- If not, set to in (ON).

Step 2. Check that ac power cable is connected to ac source.

- If not, connect to ac source.

Step 3. Check condition of line fuse.

- Replace open fuse. See para 3-10.

Step 4. Check ac power cord and connections.

- Replace ac power cord, if faulty.
- If malfunction still remains, contact next higher level of maintenance.

2. CRT DISPLAY IS NOT CORRECT FOR ANY INPUT SIGNAL.

Step 1. Check that front panel controls are set properly.

- If not, set correctly. See para 2-3.

Step 2. Check probes and connectors.

- Replace faulty probes.
- If malfunction remains, contact next higher level of maintenance.

3. ANY MALFUNCTION NOT COVERED IN (1) OR (2).

Contact next higher level of maintenance.

---

## Section IV. MAINTENANCE PROCEDURES

### 3-9. OPERATIONAL TEST

---

#### DESCRIPTION

This procedure covers: Operational readiness check of oscilloscope.

---

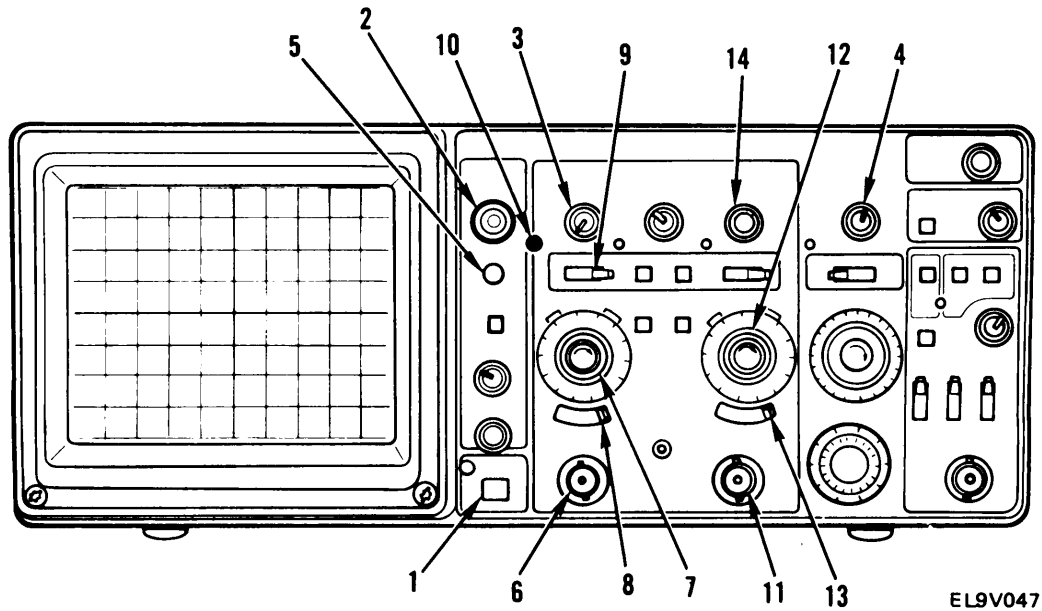

#### WARNING

Do not attempt to measure input signals that exceed the maximum input signals listed in para 1-13.

1. Set POWER ON/ Off switch (1) to OFF (out).
2. Connect oscilloscope power cord to proper ac power source
3. Depress POWER ON/OFF switch (1).
  - POWER indicator comes on.
4. Obtain baseline trace as described in para 2-3a.
  - Straight-line trace appears on crt screen,

5. Adjust A INTENSITY control (2) for desired display brightness.
6. Using channel 1 vertical POSITION control (3) and horizontal POSITION control (4), center trace on crt.

**NOTE**

If the trace is not parallel with the center horizontal graticule, adjust TRACE ROTATION pot (5).

7. Connect 10X probe to CH 1 OR X connector (5).
8. Set CH 1 VOLTS/DIV switch (6) to 0.1 10X PROBE.
9. Set channel 1 AC/ GND/ DC switch (7) to DC.
10. Set VERTICAL MODE CH 1/BOTH/CH 2 switch (8) to CH 1 and connect tip of 10X probe to AMP CAL connector (9).
  - . Trace on crt is square wave approximately five divisions in amplitude and 1 kHz in frequency.
11. Disconnect 10X probe from CH 1 OR X connector (5) and connect to CH 2 OR Y connector ( 10).
12. Set CH 2 VOLTS/DIV switch (11) to 0.1 10X PROBE.
13. Set CH 2 AC/GND/DC switch (12) to DC.
14. Set VERTICAL MODE CH 1/BOTH/CH 2 switch (8) to CH 2 and connect tip of 10 X probe to AMP CAL connector (9).
  - Trace on crt is square wave approximately five divisions in amplitude and 1 kHz in frequency.
15. Pull channel 2 vertical POSITION INVERT switch (13).
  - Crt display inverts.
16. Disconnect 10X probe and shut off oscilloscope, if desired.

**END OF TASK**

---

### 3-10. LINE FUSE REPLACEMENT

#### DESCRIPTION

This procedure covers: Remove and Install.

#### REMOVE

1. Ensure that POWER ON/ OFF switch (1) is set to OFF (out).
2. Disconnect ac power cord (2) from ac source.
3. Using common screwdriver, press in and slightly rotate fuseholder cap (3) in counter-clockwise direction to release fuseholder cap.
4. Withdraw fuseholder cap (3) with fuse (4) from fuseholder.
5. Remove fuse (4) from fuseholder cap (3).

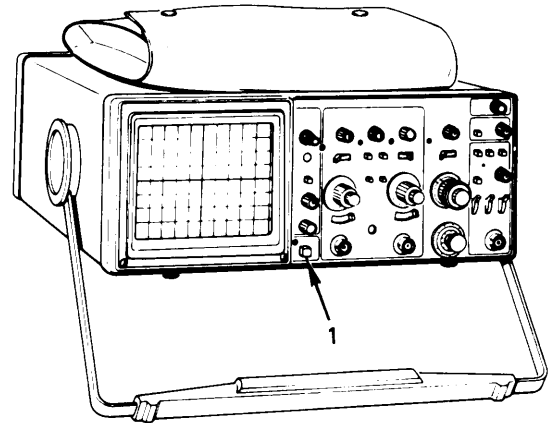

#### INSTALL

1. Install new 1.0 A, 250 V, slow-blow fuse (4) into fuseholder cap (3).
2. Insert fuse F1 and fuseholder cap (3) into fuseholder.
3. Press in and slightly rotate fuseholder cap (3) in clockwise direction to secure fuseholder cap.
4. Connect ac power cord (2) to ac source.

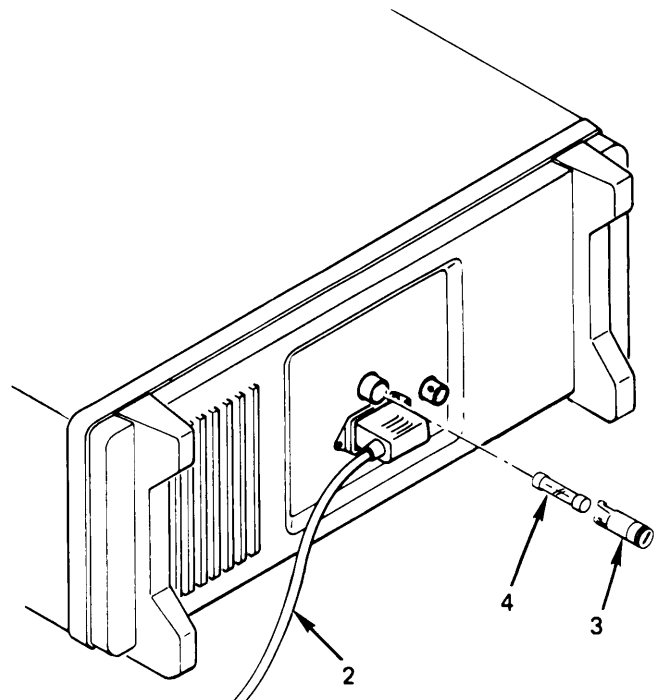

END OF TASK

### 3-11. A AND B INTENSITY KNOBS REPLACEMENT

---

#### DESCRIPTION

This procedure covers: Remove and Install.

---

#### REMOVE

1. Loosen setscrew (1) and remove inner knob (2).
2. Loosen setscrew (3) and remove outer knob (4).

#### INSTALL

1. Install outer knob (4) on shaft and tighten setscrew (3).
2. Install inner knob (2) on shaft and tighten setscrew (1).

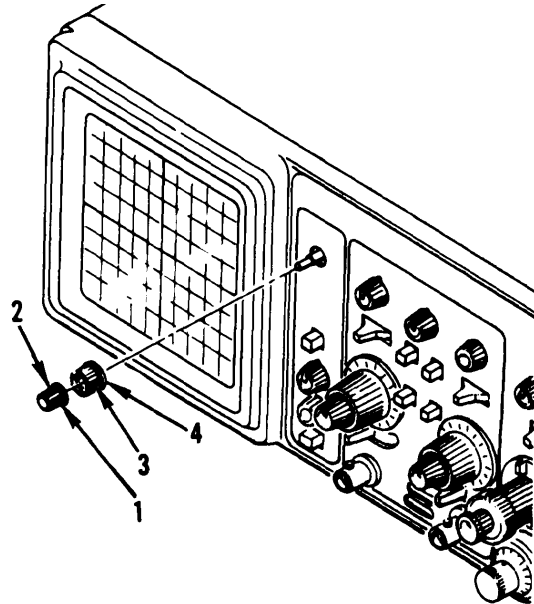

END OF TASK

---

### 3-12. CH 1 VOLTS/DIV AND CH 2 VOLTS/DIV KNOB REPLACEMENT

---

#### DESCRIPTION

This procedure covers: Remove and Install .

---

#### REMOVE

1. Loosen setscrew (1) and remove red cal knob (2).
2. Remove outer knob (3)

#### INSTALL

1. Install outer knob (3) on plastic shaft.
2. Install red cal knob (2) and tighten setscrew (1).

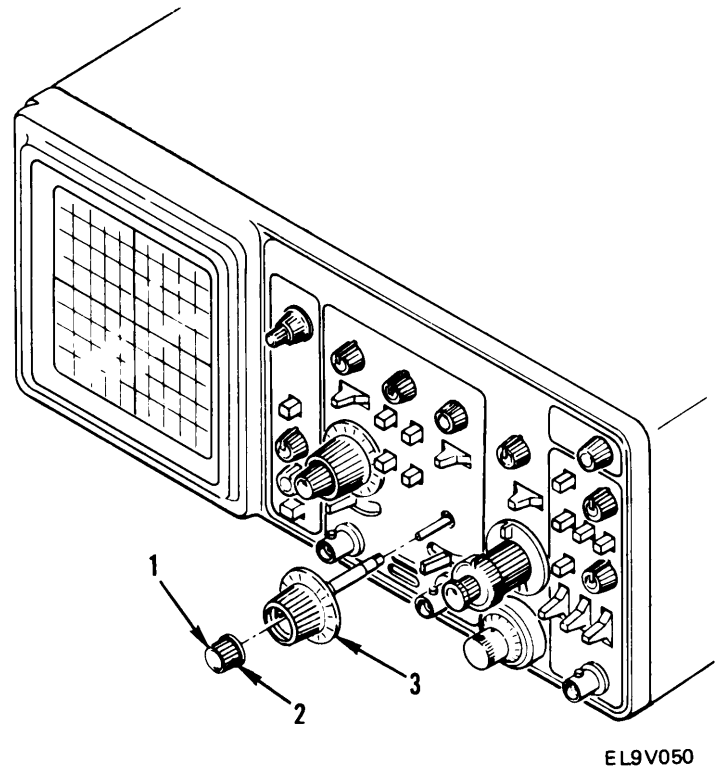

**END OF TASK**

---

### 3-13. A AND B SEC/DIV KNOB REPLACEMENT

---

#### DESCRIPTION

This procedure covers: Remove and Install.

---

#### REMOVE

1. Rotate control fully counterclockwise, then loosen setscrew (1) and remove red knob (2).
2. Loosen two setscrews (3) and remove gray knob (4).
3. Loosen two setscrews (5) and remove clear plastic knob (6).

#### INSTALL

1. Install clear plastic knob (6) and tighten two setscrews (5).
2. Install gray knob (4) and tighten two setscrews (3).
3. Install red knob (2) and tighten setscrew (1).

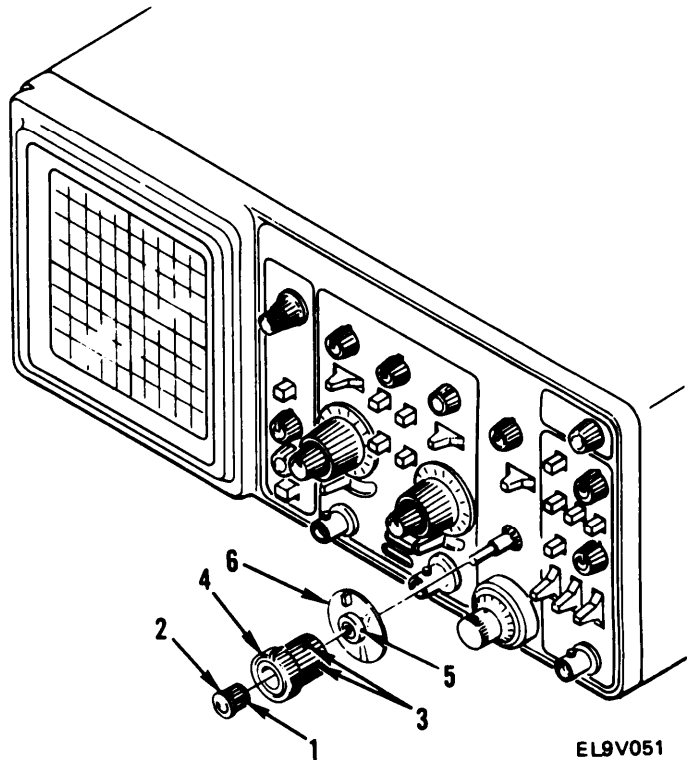

END OF TASK

---

### **3-14. CLEANING**

Loose dirt on the outside of the oscilloscope may be removed with a soft cloth or small soft-bristle brush. Dirt that remains can be removed with a soft cloth dampened in a mild detergent and water solution. Clean the light filter face with soft lint-free cloth dampened with either isopropyl alcohol, denatured ethyl alcohol, or mild detergent and water solution. The crt filter mesh should be cleaned only with isopropyl or ethyl alcohol.

## Section V. PREPARATION FOR STORAGE OR SHIPMENT

### 3-15. PREPARATION FOR STORAGE OR SHIPMENT

If original packing material was saved, pack the oscilloscope in the same manner as it was received. When using packing materials other than the original, use the following guidelines:

- a. Wrap oscilloscope in polyethylene sheeting before placing in container.
- b. Select corrugated cardboard container having inside dimensions at least 6 inches greater than oscilloscope dimensions and having a carton test strength of at least 275 pounds.
- c. Use plenty of shock-absorbing material all around the oscilloscope to protect it against damage.
- d. Seal the carton with shipping tape or an industrial stapler.
- e. Mark container "FRAGILE-DELICATE INSTRUMENT" to insure proper handling.

### 3-16. TYPES OF STORAGE

a. **Short-term (administrative)** = 1 to 45 days. All equipment in this type must be made ready within 24 hours for use on a mission. Make sure the next scheduled PMCS is done and all deficiencies corrected before placing in storage. The storage site should provide protection from extreme weather conditions and allow you to reach it for inspections or exercises, if needed.

b. **Intermediate** = 46 to 180 days.

c. **Long-term** = over 180 days.

## APPENDIX A REFERENCES

### A-1. SCOPE.

This appendix lists all forms, field manuals, technical manuals, and miscellaneous publication references in this manual.

### A-2. FORMS.

Equipment Inspection and Maintenance Worksheet.....	DA Form 2404
Product Quality Deficiency Report .....	SF 368
Recommended Changes to Publications and Blank Forms.....	DA Form 2028
Report of Discrepancy (ROD) .....	SF 364
Transportation Discrepancy Report (TDR) .....	SF 361

### A-3. TECHNICAL MANUALS.

The Army Maintenance Management System (TAMMS) Users Manual .....	DA Pam 750-8
Procedures for Destruction of Electronics Materiel to Prevent Enemy Use (Electronics Command) .....	TM 750-244-2
Organizational, Direct Support and General Support Maintenance Repair Parts and Special Tools List for Oscilloscope, AN/USM-488 (NSN 6625-01-187-7847) .....	TM 11-6625-3135-24P

### A-4. MISCELLANEOUS PUBLICATIONS.

The American Society of Mechanical Engineers, Abbreviations and Acronyms.....	ASME Y14.38
Expendable/Durable Items (Except Medical, Class V, Repair Parts, and Heraldic Items).....	CTA 50-970
Consolidated Army Publications and Forms Index .....	DA Pam 25-30
First Aid .....	FM 4-25.11
Reporting of Supply Discrepancies .....	AR 735-11-2
Safety Requirements for Maintenance of Electrical and Electronic Equipment.....	TB 385-4

## APPENDIX B

### MAINTENANCE ALLOCATION CHART

---

#### Section I. INTRODUCTION

##### B-1. General

a. This section provides a general explanation of all maintenance and repair functions authorized at various maintenance categories.

b. The Maintenance Allocation Chart (MAC) in section II designates overall authority and responsibility for the performance of maintenance functions on the identified end item or component. The application of the maintenance functions to the end item or component will be consistent with the capacities and capabilities of the designated maintenance categories,

c. Section III lists the tools and test equipment (both special tools and common tool sets) required for each maintenance function as referenced from section II.

d. Section IV contains supplemental instructions and explanatory notes for a particular maintenance function.

##### B-2. Maintenance Functions

Maintenance functions will be limited to and defined as follows:

a. *Inspect.* To determine the serviceability of an item by comparing its physical, mechanical, and /or electrical characteristics with established standards through examination (e.g., by sight, sound, or feel).

b. *Test.* To verify serviceability by measuring the mechanical and electrical characteristics of the oscilloscope and comparing these characteristics with prescribed standards.

c. *Service.* Operations required periodically to keep the oscilloscope in proper operating condition; i.e., to clean (or decontaminate), to preserve, etc.

d. *Adjust.* To maintain, within prescribed limits, by bringing into proper or exact position, or by setting the operating characteristics to specified parameters,

e. *Replace.* To remove an unserviceable item and install a serviceable counterpart in its place. Replace is authorized by the MAC and is shown as the third position code of the SMR code.

f. *Repair.* The application of maintenance services, including fault location/ troubleshooting, removal/ installation, and disassembly/ assembly procedures, and maintenance actions to identify troubles and restore serviceability to an item by correcting specific damage, fault, malfunction, or failure in a part, subassembly, module, or end item or system.

##### B-3. Explanation of Columns in the MAC (Section II)

a. *Column 1, Group Number.* Column 1 lists functional group code numbers, the purpose of which is to identify maintenance significant components, assemblies, subassemblies, and modules with the next higher assembly. End item group number shall be 00.

b. *Column 2, Component/Assembly.* Column 2 contains the names of components, assemblies, subassemblies, and modules for which maintenance is authorized.

c. *Column 3, Maintenance Function.* Column 3 lists the functions to be performed on the item listed in column 2 (see para B-2).

d. *Column 4, Maintenance Category.* Column 4 specifies, by the listing of a "worktime" figure in the appropriate subcolumn(s), the category of maintenance authorized to perform the function listed in column 3. This figure represents the active time required to perform that maintenance function at the indicated category of maintenance. If the number or complexity of the tasks within the listed maintenance function vary at different maintenance categories, appropriate "worktime" figures will be shown for each category. The "worktime" figure represents the average time required to restore an item (assembly, subassembly, component, module, end item, or system) to a serviceable condition under typical field operating conditions. This time includes preparation time (including any necessary disassembly/ assembly time), troubleshooting/fault location time, and quality assurance/ quality control time

in addition to the time required to perform the specific tasks identified for the maintenance functions authorized in the MAC. The symbol designations for the maintenance categories are as follows:

- c — Operator or Crew
- O — Organizational Maintenance
- F — Direct Support Maintenance
- H — General Support Maintenance
- D — Depot Maintenance

*e. Column 5, Tools and Equipment.* Column 5 specifies by code, those common tool sets (not individual tools) and special tools, TM DE, and support equipment required to perform the designated function.

*f. Column 6, Remarks.* This column shall, when applicable, contain a letter code, in alphabetic order, which shall be keyed to the remarks contained in section IV.

**B-4. Explanation of Columns in  
Tool and Test Equipment Requirement  
(Section III)**

*a. Column 1, Reference Code.* The tool and test equipment reference code correlates with a code used in the MAC, section II, column 5.

*b. Column 2, Maintenance Category.* The lowest category of maintenance authorized to use the tool or test equipment.

*c. Column 3, Nomenclature.* Name or identification of the tool or test equipment

*d. Column 4, National Stock Number.* The national stock number of the tool or test equipment.

*e. Column 5, Tool Number.* The manufacturer's part number.

**B-5. Explanation of Columns in Remarks  
(Section IV)**

*a. Column 1, Reference Code.* The code recorded in column 6, section II.

*b. Column 2, Remarks.* This column lists information pertinent to the maintenance function being performed as indicated in the MAC, section II.

**SECTION II. MAINTENANCE ALLOCATION CHART  
FOR  
OSCILLOSCOPE AN/USM-488**

(1) GROUP NUMBER	(2) COMPONENT/ASSEMBLY	(3) MAINTENANCE FUNCTION	(4) MAINTENANCE CATEGORY					(5) TOOLS AND EQPT.	(6) REMARKS
			C	O	F	H	D		
00	OSCILLOSCOPE AN/USM-488 TEKTRONIX TYPE 2235	Inspect Test Cal Repair Repair		0.1   0.5		2.0 3.0  2.0		Visual 2 thru 15 2 thru 15 1 16, 17	A
01	MAIN CIRCUIT BOARD ASSY A1, PART NO. 670-8404-00	Inspect Test Replace Repair				0.2 2.0 1.5 1.5		16, 17 2 thru 15 16, 17 16, 17	B

**SECTION III. TOOL AND TEST EQUIPMENT REQUIREMENTS  
FOR  
OSCILLOSCOPE AN/USM-488**

TOOL OR TEST EQUIPMENT REF CODE	MAINTENANCE CATEGORY	NOMENCLATURE	NATIONAL/NATO STOCK NUMBER	TOOL NUMBER
1	O	Tool Kit, Electronic Equipment, TK-101/G	5180-00-064-5178	
2	H	Oscilloscope Calibrator, Ballantine 6126M	6695-01-057-2207	
3	H	Power Modular Main Frame, TEKTRONIX Type RTM-506	6625-01-048-8920	
4	H	Function Generator, TEKTRONIX Type FG 502	6625-01-074-7956	
5	H	Cable, 2 ea., 50 Ohms, RG-58/U, 42 in., TEKTRONIX Part No. 012-0057-01	6625-00-495-4831	
6	H	Termination, 2 ea., TEKTRONIX Part No. 011-0049-01	5985-00-087-4954	
7	H	Dual-Input Coupler, TEKTRONIX Part No. 067-0525-02	6695-01-058-2187	
8	H	10X Attenuator, TEKTRONIX Part No. 011-0059-02	5985-00-572-7428	
9	H	T-Connector, BNC, TEKTRONIX Part No. 103-0030-00	5935-00-284-1962	
10	H	Digital Multimeter, TEKTRONIX Type DM501A	6625-01-075-8583	
11	H	Test Oscilloscope with included 10X Probe, TEKTRONIX Type SC 504	6695-01-074-7954	
12	H	Multimeter, Digital, Hewlett Packard Model 3490A	6625-00-557-8305	
13	H	Isolation Transformer		
14	H	X1 Probe, TEKTRONIX Part No. 010-6101-03		
15	H	Probe, High-Voltage, Hewlett Packard Model K25-3490A	6625-01-023-6253	
16	H	Torx Screwdrivers, TEKTRONIX Part Nos. 003-1293-00, 003-0965-00, 003-0814-00, 003-0966-00, and 003-0866-00		
17	H	Tool Kit, Electronic Equipment, JTK-17LAL	4931-01-073-3845	

SECTION IV. REMARKS

REFERENCE CODE	REMARKS
<p>A</p> <p>B</p>	<p>Repair by replacing knobs and fuse.</p> <p>Circuit Board Assemblies A2 thru A8 and A10 are not repairable. These assemblies are to be replaced and disposed of when found to be non-operational.</p>

# APPENDIX C

## COMPONENTS OF END ITEM AND BASIC ISSUE ITEMS LISTS

### Section I. INTRODUCTION

#### C-1. SCOPE

This appendix lists components of end item and basic issue items for the Oscilloscope AN/ USM-488 to help you inventory items required for safe and efficient operation.

#### C-2. GENERAL

The Components of End Item and Basic Issue Items Lists are divided into the following sections:

a. **Section II. Components of End Item.** This listing is for informational purposes only, and is not authority to requisition replacements. These items are part of the end item, but are removed and separately packaged for transportation or shipment. As part of the end item, these items must be with the end item whenever it is issued or transferred between property accounts. Illustrations are furnished to assist you in identifying the items.

b. **Section III. Basic Issue Items (BII).** These are the minimum essential items required to place the oscilloscope in operation, to operate it, and to perform emergency repairs. Although shipped separately packaged, BII must be with the oscilloscope during operation and whenever it is transferred between property accounts. The illustrations will assist you with hard-to-identify items. This manual is your authority to request/requisition replacement BII, based on TOE/MTOE authorization of the end item.

#### C-3. EXPLANATION OF COLUMNS

The following is an explanation of columns found in the tabular listings:

a. **Column (1) - Illustration Number (Illust. No.).** This column indicates the number of the illustration in which the item is shown.

b. **Column (2) - National Stock Number.** Indicates the National stock number assigned to the item and will be used for requisitioning purposes.

c. **Column (3) - Description.** Indicates the Federal item name and, if required, a minimum description to identify and locate the item. The last line for each item indicates the Federal Supply Code for Manufacturer (FSCM) (in parentheses) followed by the part number. If item needed differs for different models of this equipment, the model is shown under the Usable On heading in this column.

d. **Column (4) - Unit of Measure (U/M).** Indicates the measure used in performing the actual operational/ maintenance function. This measure is expressed by a two-character alphabetical abbreviation (e.g., ea, in, pr).

e. **Column (5) - Quantity Required (Qty Rqr).** Indicates the quantity of the item authorized to be used with the oscilloscope.

## Section II. COMPONENTS OF END ITEM

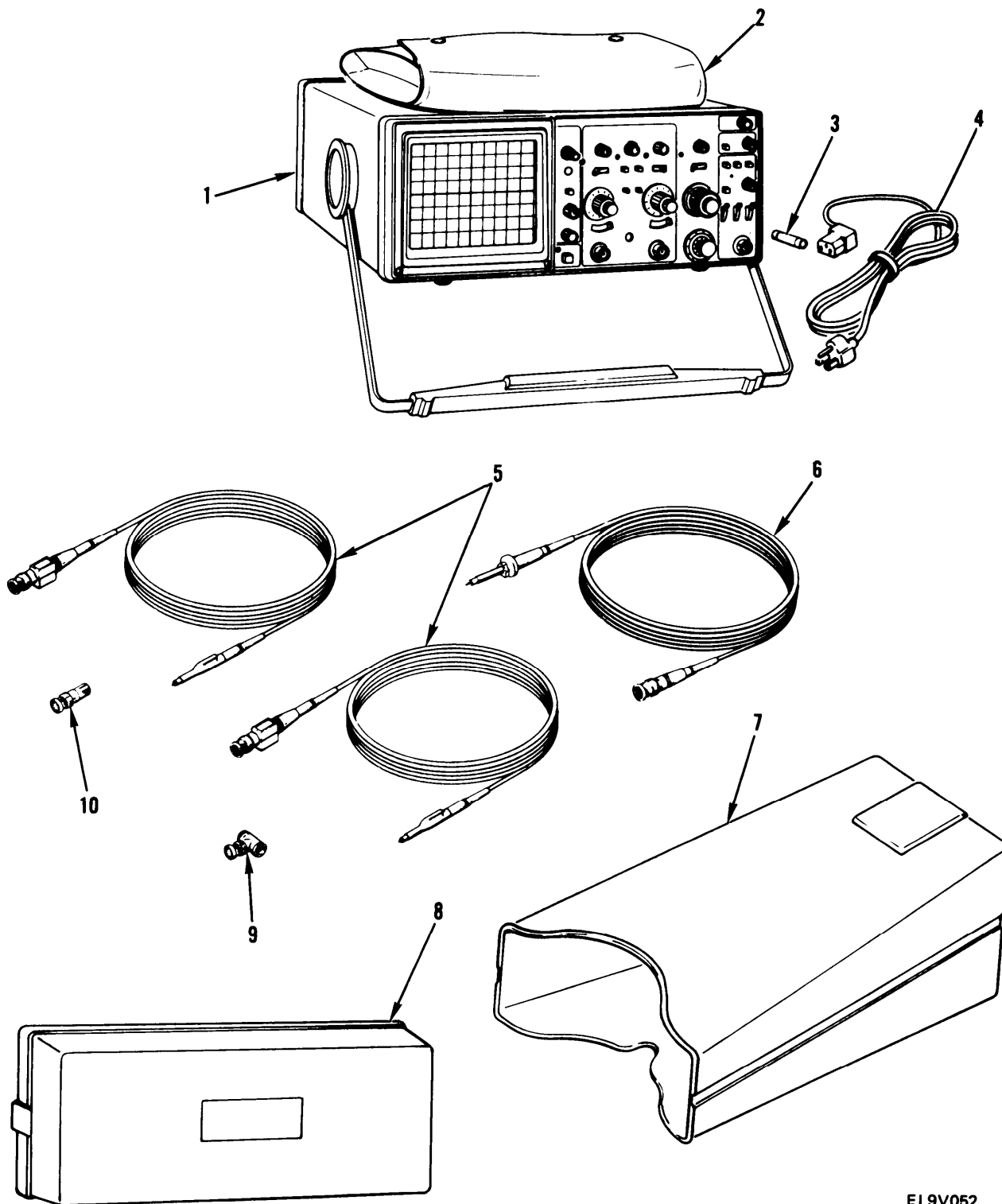

EL9V052

(1) Illust. No.	(2) National Stock Number	(3) Description FSCM and Part Number	Usable On Code	(4) U/M	(5) Qty Rqr
1		Oscilloscope, Model 2235 (80009)		ea	1
2		Pouch (80009) 016-0677-02		ea	1
3		Fuse (71400) NDL1		ea	1
4		AC Power Cord (16428) CH8352		ea	1
5		10X Probe Set (80009) 010-6122-01		st	2
6		IX Probe Set (80009) 010-6101-03		st	1
7		Viewing Hood (80009) 016-0566-00		ea	1
8		Cover (80009) 200-2520-00		ea	1
9		BNC Tee Connector (95712) 3424-9		ea	1
10		BNC to Binding Post Connector (95712) 2048-2NT34		ea	1

## APPENDIX D EXPENDABLE SUPPLIES AND MATERIALS LIST

### Section I. INTRODUCTION

#### D-1. SCOPE

This appendix lists expendable supplies and materials you will need to operate and maintain the Oscilloscope AN/USM-488. These items are authorized to you by CTA 50-970, Expendable/Durable Items (Except Medical, Class V, Repair Parts, and Heraldic Items).

#### D-2. EXPLANATION OF COLUMNS

**a. Column (1) - Item Number.** This number is assigned to the entry in the listing and is referenced in the narrative instructions to identify the material.

**b. Column (2) - Level.** This column identifies the lowest level of maintenance that requires the listed item. Enter as applicable:

- C - Operator/Crew
- O - Organizational Maintenance
- F - Direct Support Maintenance
- H - General Support Maintenance

**c. Column (3) - National Stock Number.** This is the National stock number assigned to the item; use it to request or requisition the item.

**d. Column (4) - Description.** Indicates the Federal item name and, if required, a description to identify the item. The last line for each item indicates the Federal Supply Code for Manufacturer (FSCM) (in parentheses) followed by the part number.

**e. Column (5) - Unit of Measure (U/M).** Indicates the measure used in performing the actual maintenance function. This measure is expressed by a two-character alphabetical abbreviation (e.g., ea, in, pr). If the unit of measure differs from the unit of issue, requisition the lowest unit of issue that will satisfy your requirements.

### Section II. EXPENDABLE SUPPLIES AND MATERIALS

(1) ITEM NUMBER	(2) LEVEL	(3) NATIONAL STOCK NUMBER	(4) DESCRIPTION	(5) U/M
1	O	8305-00-267-3015	Cloth, Cheesecloth, Cotton, Lintless, CCC-C-440, Type II, Class 2 (81348)	YD
2	O		Detergent, Mild, Liquid	OZ
3	O		Denatured Ethyl Alcohol	OZ
4	O	6810-01-382-2904	Alcohol, Isopropyl, 1.01 Fluid Oz, Bottle, ASTM D 770 (81346)	BX

## INDEX

Subject	Paragraph, Figure, Table, Number
<b>A</b>	
A and B Intensity Knobs Replacement .....	3-11
A and B Sec/Div Knob Replacement .....	3-13
Abbreviations. List of .....	1-10
Algebraic Addition, Operating Procedures .....	2-3e
Amplitude Comparison (Ratio), Operating Procedures .....	2-3g
AN/USM-488 Oscilloscope Block Diagram .....	F 1-2
Appendices	
A — References .....	A-1
B — Maintenance Allocation Chart .....	B-1
C — Components of End Item and Basic Issue Items Lists .....	C-1
D — Expendable Supplies and Materials List .....	D-1
<b>C</b>	
CH 1 Volts/Div and CH2 Volts/Div Knob Replacement .....	3-12
Checking Unpacked Equipment .....	3-5
Cleaning .....	3-14
Common Tools and Equipment .....	3-1
Common-Mode Rejection, Operating Procedures .....	2-3f
Components of End Item and Basic Issue Items Lists .....	C-1
Consolidated Index of Army Publications and Blank Forms .....	1-2
Controls, Preset Positions .....	T 2-2
<b>D</b>	
Destruction of Army Material to Prevent Enemy Use .....	1-4
<b>E</b>	
Equipment Description	
Equipment Characteristics, Capabilities, and Features .....	1-11
Equipment Data .....	1-13
Location and Description of Major Components .....	1-12
Expendable Supplies and Materials List .....	D-1
<b>F</b>	
Frequency Measurement, Operating Procedures .....	2-3i
Functional Description .....	1-14

Subject

**G**

General Information

Consolidated Index of Army Publications and Blank Forms . . . . .	1-2
Destruction of Army Material to Prevent Enemy Use . . . . .	1-4
List of Abbreviations . . . . .	1-10
Maintenance Forms, Records, and Reports . . . . .	1-3
Nomenclature Cross-Reference List . . . . .	1-7
Preparation for Storage or Shipment . . . . .	1-5
Reporting Equipment Improvement Recommendations (EIR) . . . . .	1-8
Safety Care and Handling . . . . .	1-8
Scope . . . . .	1-1
Warranty Information . . . . .	1-9

**I**

Initial Checks, Adjustments and Tests. . . . .	3-6
Instantaneous Voltage Measurement, Operating Procedures . . . . .	2-3d

**L**

Line Fuse Replacement . . . . .	3-10
List of Abbreviations . . . . .	1-10
Location and Description of Major Components . . . . .	1-12

**M**

Magnified Sweep Runs After Delay, Operating Procedures . . . . .	2-3m
Maintenance Allocation Chart . . . . .	B-1
Maintenance Forms, Records, and Reports . . . . .	1-3
Maintenance Procedures	
A and B Intensity Knobs Replacement . . . . .	3-11
A and B Sec/DivKnobReplacement . . . . .	3-13
CH 1 Volts/ Div and CH 2 Volts/Div Knob Replacement . . . . .	3-12
Cleaning . . . . .	3-14
Line Fuse Replacement . . . . .	3-10
Operational Test . . . . .	3-9
Measurement of Time Difference Between Pulses on Time-Related Signals, Operating Procedures . . . . .	2-3r

**N**

Nomenclature Cross-Reference List . . . . .	1-7
---	-----

Subject	Paragraph, Figure, Table, Number
O	
Obtaining Baseline Trace, Operating Procedures .....	2-3a
Operating Procedures .....	2-3
Operation in Unusual Weather .....	2-4
Operation Under Usual Conditions	
Operating Procedures .....	2-3
Algebraic Addition .....	2-3e
Amplitude Comparison (Ratio) .....	2-3g
Common-Mode Rejection .....	2-3f
Frequency Measurement .....	2-3i
Instantaneous Voltage Measurement .....	2-3d
Magnified Sweep Runs After Delay .....	2-3m
Measurement of Time Difference Between Pulses on Time-Related Signals .....	2-3r
Obtaining Baseline Trace .....	2-3a
Peak-To-Peak Voltage Measurements .....	2-3c
Phase Difference Measurement .....	2-31
Probe Compensation .....	2-3b
Pulse Jitter Time Measurement .....	2-3n
Rise Time Measurement in Delayed-Sweep Mode .....	2-3k
Rise Time Measurement .....	2-3j
Time Difference Measurement Between Two Pulses on Two Time-Related Signals in Delayed Sweep Mode .....	2-3s
Time Difference Measurement on Single Waveform .....	2-3q
Time Duration Measurement .....	2-3h
Triggered Magnified Sweep Measurement .....	2-3p
Operational Test .....	3-9
Operator Preventive Maintenance Checks and Services (PMCS)	
General .....	2-1
PMCS Table .....	2-2
Oscilloscope AN/USM-488 .....	F 1-1
Oscilloscope PMCS Location Diagram .....	F 2-1

P

Peak-To-Peak Voltage Measurements, Operating Procedures .....	2-3c
Phase Difference Measurement, Operating Procedures .....	2-31
PMCS Table .....	2-2
Preparation for Storage or Shipment	
Preparation for Storage or Shipment .....	3-15
Types of Storage .....	3-16
Intermediate .....	3-16b
Long-term .....	3-16c
Short-term (administrative) .....	3-16a

Subject	Paragraph, Figure, Table, Number
Preparation for Storage or Shipment . . . . .	1-5, 3-15
Probe Compensation, Operating Procedures . . . . .	2-3b
Pulse Jitter Time Measurement, Operating Procedures . . . . .	2-3n
<b>R</b>	
References . . . . .	A-1
Remarks . . . . .	B-5
Repair Parts, Special Tools; Test, Measurement, and Diagnostic Equipment (TMDE); and Support Equipment	
Common Tools and Equipment . . . . .	3-1
Repair Parts . . . . .	3-3
Special Tools, TMDE, and Support Equipment . . . . .	3-2
Reporting Equipment Improvement Recommendations (EAR) . . . . .	1-8
Rise Time Measurement in Delayed-Sweep Mode, Operating Procedures . . . . .	2-3k
Rise Time Measurement, Operating Procedures . . . . .	2-3j
<b>S</b>	
Safety Precautions . . . . .	3-7
Safety, Care, and Handling . . . . .	1-6
Scope . . . . .	1-1
Service Upon Receipt	
Checking Unpacking Equipment . . . . .	3-5
Initial Checks, Adjustments and Tests . . . . .	3-6
Unpacking . . . . .	3-4
Special Tools, TMDE, and Support Equipment . . . . .	3-2
<b>T</b>	
Technical Principles of Operation	
Functional Description . . . . .	1-14
Time Difference Measurement Between Two Pulses on Two	
Time-Related Signals in Delayed Sweep Mode, Operating Procedures . . . . .	2-3Ss
Time Difference Measurement on Single Waveform, Operating Procedures . . . . .	2-3q
Time Duration Measurement, Operating Procedures . . . . .	2-3h
Tool and Test Equipment Requirements for Oscilloscope AN/USM-488... . . . .	B-4
Triggered Magnified Sweep Measurement, Operating Procedures . . . . .	2-3p
Troubleshooting	
Safety Precautions . . . . .	3-7
Troubleshooting Procedures . . . . .	3-8
Types of Storage . . . . .	3-16

Subject	Paragraph, Figure, Table, Number
<b>U</b>	
Unpacking . . . . .	3-4
<b>W</b>	
Warranty Information . . . . .	1-8

By Order of the Secretary of the Army:

Official:

JOHN A. WICKHAM, JR.  
*General, United States Army*  
*Chief of Staff*

R.L. DILWORTH  
*Brigadier General, United States Army*  
*The Adjutant General*

DISTRIBUTION:

To be distributed in accordance with DA Form 12-51 literature requirements for AN/USM-488.

\*U.S. GOVERNMENT PRINTING OFFICE : 1995 0- 394-018

## ***These are the instructions for sending an electronic 2028***

The following format must be used if submitting an electronic 2028. The subject line must be exactly the same and all fields must be included; however only the following fields are mandatory: 1, 3, 4, 5, 6, 7, 8, 9, 10, 13, 15, 16, 17, and 27.

From: "Whomever" <whomever@wherever.army.mil>

To: 2028@redstone.army.mil

Subject: DA Form 2028

1. **From:** Joe Smith
2. **Unit:** home
3. **Address:** 4300 Park
4. **City:** Hometown
5. **St:** MO
6. **Zip:** 77777
7. **Date Sent:** 19-OCT-93
8. **Pub no:** 55-2840-229-23
9. **Pub Title:** TM
10. **Publication Date:** 04-JUL-85
11. **Change Number:** 7
12. **Submitter Rank:** MSG
13. **Submitter FName:** Joe
14. **Submitter MName:** T
15. **Submitter LName:** Smith
16. **Submitter Phone:** 123-123-1234
17. **Problem:** 1
18. **Page:** 2
19. **Paragraph:** 3
20. **Line:** 4
21. **NSN:** 5
22. **Reference:** 6
23. **Figure:** 7
24. **Table:** 8
25. **Item:** 9
26. **Total:** 123
27. **Text:**

This is the text for the problem below line 27.



<b>TO:</b> (Forward direct to addressee listed in publication) Commander, U.S. Army Aviation and Missile Command ATTN: AMSAM-MMC-MA-NP Redstone Arsenal, 35898	<b>FROM:</b> (Activity and location) (Include ZIP Code) MSG, Jane Q. Doe 1234 Any Street Nowhere Town, AL 34565	<b>DATE</b> 8/30/02
---	--	------------------------

**PART II - REPAIR PARTS AND SPECIAL TOOL LISTS AND SUPPLY CATALOGS/SUPPLY MANUALS**

PUBLICATION NUMBER			DATE	TITLE				
PAGE NO.	COLM NO.	LINE NO.	NATIONAL STOCK NUMBER	REFERENCE NO.	FIGURE NO.	ITEM NO.	TOTAL NO. OF MAJOR ITEMS SUPPORTED	RECOMMENDED ACTION

**PART III - REMARKS** (Any general remarks, corrections, or suggestions for improvement of publications and blank forms. Additional blank sheets may be used if more space is needed.)

**EXAMPLE**

TYPED NAME, GRADE OR TITLE MSG, Jane Q. Doe, SFC	TELEPHONE EXCHANGE/AUTOVON, PLUS EXTENSION 788-1234	SIGNATURE
---	--	-----------

<b>RECOMMENDED CHANGES TO PUBLICATIONS AND BLANK FORMS</b> <small>For use of this form, see AR 25-30; the proponent agency is ODISC4.</small>						Use Part II (reverse) for Repair Parts and Special Tool Lists (RPSTL) and Supply Catalogs/Supply Manuals (SC/SM)	DATE
TO: (Forward to proponent of publication or form)(Include ZIP Code)						FROM: (Activity and location)(Include ZIP Code)	
<b>PART 1 - ALL PUBLICATIONS (EXCEPT RPSTL AND SC/SM) AND BLANK FORMS</b>							
PUBLICATION/FORM NUMBER						DATE	TITLE
ITEM NO.	PAGE NO.	PARA-GRAPH	LINE NO. *	FIGURE NO.	TABLE NO.	RECOMMENDED CHANGES AND REASON	
<i>* Reference to line numbers within the paragraph or subparagraph.</i>							
TYPED NAME, GRADE OR TITLE						TELEPHONE EXCHANGE/ AUTOVON, PLUS EXTENSION	SIGNATURE

<b>TO:</b> (Forward direct to addressee listed in publication)	<b>FROM:</b> (Activity and location) (Include ZIP Code)	<b>DATE</b>
--	---	-------------

**PART II - REPAIR PARTS AND SPECIAL TOOL LISTS AND SUPPLY CATALOGS/SUPPLY MANUALS**

PUBLICATION NUMBER	DATE	TITLE
--------------------	------	-------

PAGE NO.	COLM NO.	LINE NO.	NATIONAL STOCK NUMBER	REFERENCE NO.	FIGURE NO.	ITEM NO.	TOTAL NO. OF MAJOR ITEMS SUPPORTED	RECOMMENDED ACTION

**PART III - REMARKS** (Any general remarks or recommendations, or suggestions for improvement of publications and blank forms. Additional blank sheets may be used if more space is needed.)

TYPED NAME, GRADE OR TITLE	TELEPHONE EXCHANGE/AUTOVON, PLUS EXTENSION	SIGNATURE
----------------------------	--	-----------

<b>RECOMMENDED CHANGES TO PUBLICATIONS AND BLANK FORMS</b> <small>For use of this form, see AR 25-30; the proponent agency is ODISC4.</small>						Use Part II (reverse) for Repair Parts and Special Tool Lists (RPSTL) and Supply Catalogs/Supply Manuals (SC/SM)	DATE
TO: (Forward to proponent of publication or form)(Include ZIP Code)						FROM: (Activity and location)(Include ZIP Code)	
<b>PART 1 - ALL PUBLICATIONS (EXCEPT RPSTL AND SC/SM) AND BLANK FORMS</b>							
PUBLICATION/FORM NUMBER						DATE	TITLE
ITEM NO.	PAGE NO.	PARA-GRAPH	LINE NO. *	FIGURE NO.	TABLE NO.	RECOMMENDED CHANGES AND REASON	
<i>* Reference to line numbers within the paragraph or subparagraph.</i>							
TYPED NAME, GRADE OR TITLE						TELEPHONE EXCHANGE/ AUTOVON, PLUS EXTENSION	SIGNATURE

<b>TO:</b> (Forward direct to addressee listed in publication)	<b>FROM:</b> (Activity and location) (Include ZIP Code)	<b>DATE</b>
--	---	-------------

**PART II - REPAIR PARTS AND SPECIAL TOOL LISTS AND SUPPLY CATALOGS/SUPPLY MANUALS**

<b>PUBLICATION NUMBER</b>	<b>DATE</b>	<b>TITLE</b>
---------------------------	-------------	--------------

PAGE NO.	COLM NO.	LINE NO.	NATIONAL STOCK NUMBER	REFERENCE NO.	FIGURE NO.	ITEM NO.	TOTAL NO. OF MAJOR ITEMS SUPPORTED	RECOMMENDED ACTION

**PART III - REMARKS** (Any general remarks or recommendations, or suggestions for improvement of publications and blank forms. Additional blank sheets may be used if more space is needed.)

TYPED NAME, GRADE OR TITLE	TELEPHONE EXCHANGE/AUTOVON, PLUS EXTENSION	SIGNATURE
----------------------------	--	-----------

<b>RECOMMENDED CHANGES TO PUBLICATIONS AND BLANK FORMS</b> For use of this form, see AR 25-30; the proponent agency is ODISC4.						Use Part II (reverse) for Repair Parts and Special Tool Lists (RPSTL) and Supply Catalogs/Supply Manuals (SC/SM)	DATE
TO: (Forward to proponent of publication or form)(Include ZIP Code)						FROM: (Activity and location)(Include ZIP Code)	
<b>PART 1 - ALL PUBLICATIONS (EXCEPT RPSTL AND SC/SM) AND BLANK FORMS</b>							
PUBLICATION/FORM NUMBER						DATE	TITLE
ITEM NO.	PAGE NO.	PARA-GRAPH	LINE NO. *	FIGURE NO.	TABLE NO.	RECOMMENDED CHANGES AND REASON	
<i>* Reference to line numbers within the paragraph or subparagraph.</i>							
TYPED NAME, GRADE OR TITLE						TELEPHONE EXCHANGE/ AUTOVON, PLUS EXTENSION	SIGNATURE

<b>TO:</b> (Forward direct to addressee listed in publication)	<b>FROM:</b> (Activity and location) (Include ZIP Code)	<b>DATE</b>
--	---	-------------

**PART II - REPAIR PARTS AND SPECIAL TOOL LISTS AND SUPPLY CATALOGS/SUPPLY MANUALS**

PUBLICATION NUMBER	DATE	TITLE
--------------------	------	-------

PAGE NO.	COLM NO.	LINE NO.	NATIONAL STOCK NUMBER	REFERENCE NO.	FIGURE NO.	ITEM NO.	TOTAL NO. OF MAJOR ITEMS SUPPORTED	RECOMMENDED ACTION

**PART III - REMARKS** (Any general remarks or recommendations, or suggestions for improvement of publications and blank forms. Additional blank sheets may be used if more space is needed.)

TYPED NAME, GRADE OR TITLE	TELEPHONE EXCHANGE/AUTOVON, PLUS EXTENSION	SIGNATURE
----------------------------	--	-----------

