



OPERATING INSTRUCTIONS



dPMR446/PMR446 TRANSCEIVER
IC-F29DR3



INTRODUCTION

Thank you for choosing this Icom product.

This product was designed and built with Icom's state of the art technology and craftsmanship. With proper care, this product should provide you with years of trouble-free operation.

IMPORTANT

FIRST, CAREFULLY READ INSTRUCTIONS that is provided with the transceiver.

SAVE THIS OPERATING INSTRUCTIONS— This operating instructions contains additional important operating instructions for the following transceivers.

This transceiver includes some functions that are usable only when they are preset by your dealer. Ask your Icom dealer or system operator for details.

TABLE OF CONTENTS

1 ACCESSORIES	1	5 SETTINGS	16
Attaching or detaching accessories.....	1	Setting the Beep function	16
HM-222HLWP SPEAKER MICROPHONE.....	3	Setting the beep and announcement level	17
2 PANEL DESCRIPTION.....	4	Setting the Call-Ring pattern	18
Front, top and side panels.....	4	Setting the ringer level.....	19
Status indicator.....	5	Setting the microphone gain.....	20
Assignable Software Key functions	7	Setting the squelch level	21
3 BASIC OPERATION	10	Setting the VOX function	22
Turning ON the transceiver	10	Setting the VOX gain.....	23
Selecting a Zone and a channel.....	10	Setting a scan type.....	24
Call procedure	11	6 dPMR OPERATION.....	25
Receiving and transmitting	12	Receiving a call	25
4 ADVANCED OPERATION.....	13	Transmitting a call	26
Alert-Ring call	13		
Sounding a Siren.....	14		
AquaQuake Water Draining function.....	14		
Tone Scan function	15		

Icom and the Icom logo are registered trademarks of Icom Incorporated (Japan) in Japan, the United States, the United Kingdom, Germany, France, Spain, Russia, Australia, New Zealand, and/or other countries.

AquaQuake is a trademark of Icom Incorporated.

dPMR and the dPMR logo are trademarks of the dPMR MoU Association.

All other products or brands are registered trademarks or trademarks of their respective holders.

Icom is not responsible for the destruction, damage to, or performance of any Icom or non-Icom equipment, if the malfunction is because of:

- Force majeure, including, but not limited to, fires, earthquakes, storms, floods, lightning, other natural disasters, disturbances, riots, war, or radioactive contamination.
- The use of Icom transceivers with any equipment that is not manufactured or approved by Icom.

Section 1 ACCESSORIES

Attaching or detaching accessories

◇ Battery pack

Attaching:

1. Slide the battery pack in the direction of the arrow. (1)
2. Push the battery pack until the battery sliding locks make a 'click' sound. (2)

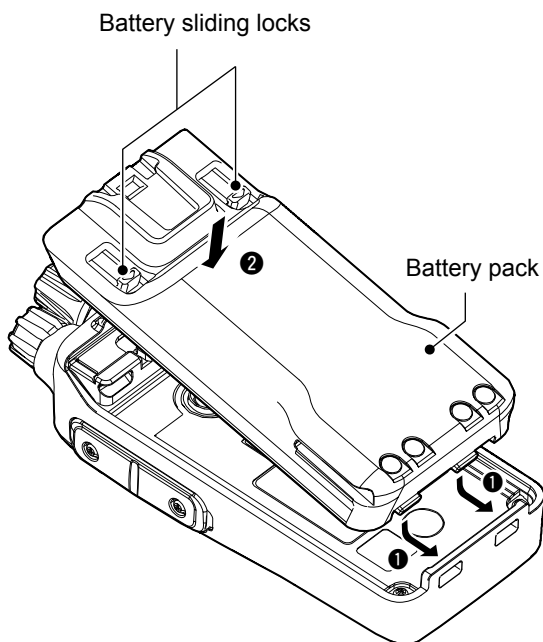

Detaching:

1. Pull both battery sliding locks in the direction of the arrow. (1)
 - The battery pack is then released.
2. Lift up to detach the battery pack. (2)

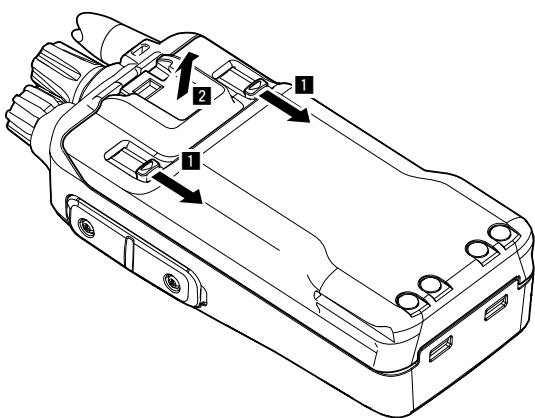

◇ Belt clip

Attaching:

1. Remove the battery pack from the transceiver if it is attached.
2. Slide the belt clip in the direction of the arrow until the belt clip is locked and makes a 'click' sound.

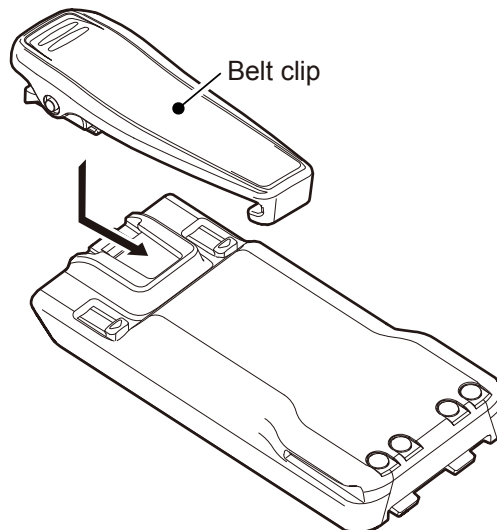

Detaching:

- Lift the tab up (1), and slide the belt clip in the direction of the arrow. (2)

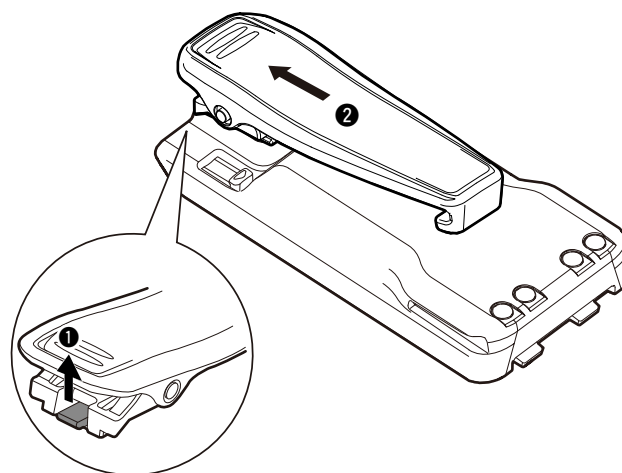

BE CAREFUL! DO NOT break your fingernail.

Attaching or detaching accessories

◇ Jack cover

CAUTION: DO NOT use the transceiver without the connector cover or optional equipment attached. The transceiver meets IP67 requirements for dust-tight and waterproof protection only when the connector cover or the HM-222HLWP, HS-94LWP, or HS-95LWP is attached.

Attaching:

1. Place the jack cover over the speaker-microphone jack. (1)
2. Insert and tighten the screws. (2)

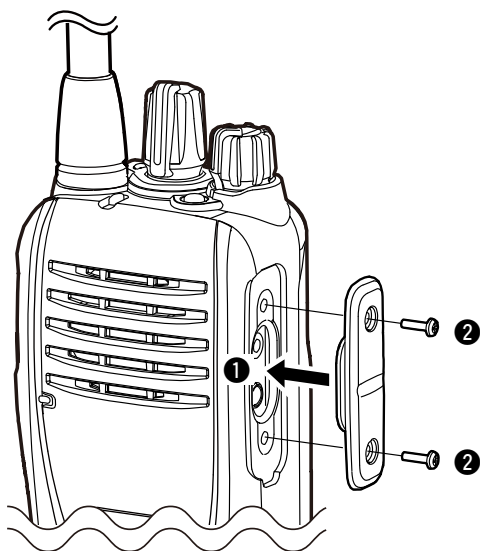

Detaching:

1. Unscrew the screws using a Phillips screwdriver. (1)
2. Detach the jack cover. (2)

CAUTION: DO NOT detach the jack cover when optional equipment is going to be used. Otherwise, the terminals of the speaker microphone jack may be shorted by a metal object or become rusty by water intrusion. This could damage the transceiver.

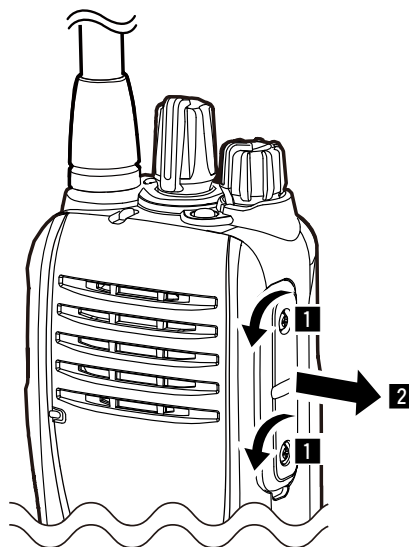

HM-222HLWP SPEAKER MICROPHONE

① The high audio output of the HM-222HLWP is only usable with transceivers that support the function.

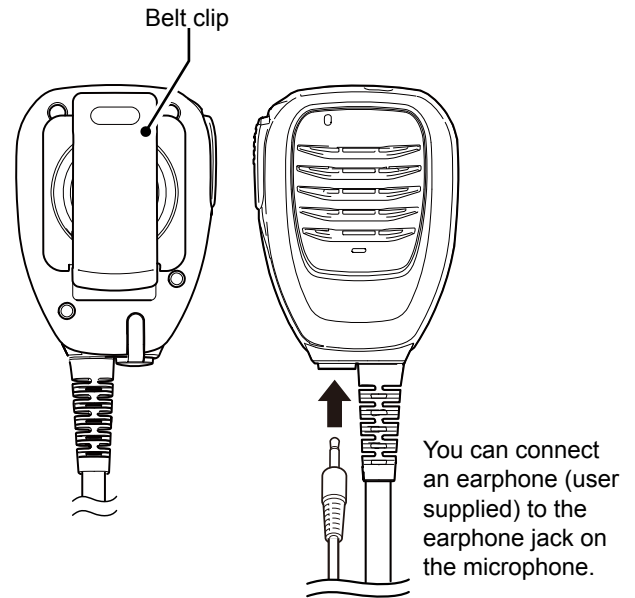
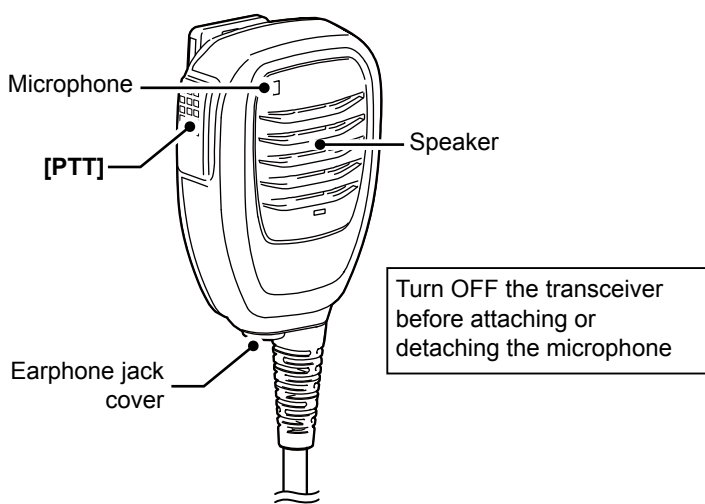

NOTE:

- **NEVER** immerse the connector in water. If the connector becomes wet, be sure to dry it **BEFORE** attaching to the transceiver.
- The microphone element is located at the top left of the speaker microphone, as shown in the illustration above. To maximize the readability of your transmitted audio, hold the microphone approximately 5 to 10 cm (2 to 4 inches) from your mouth, and then speak at your normal voice level.

CAUTION: The HM-222HLWP meets IP68 requirement for dust-tight and waterproof protection only when the earphone jack cover is firmly closed. The microphone **DOES NOT** meet dust-tight and waterproof protection if an earphone is attached.

◆ Attaching

Attach the connector of the speaker microphone to the speaker microphone jack on the transceiver and tighten the screw.

NOTE: **KEEP** the jack cover attached to the transceiver when the speaker microphone is not in use to keep the IP67 dust-tight and waterproof protection.

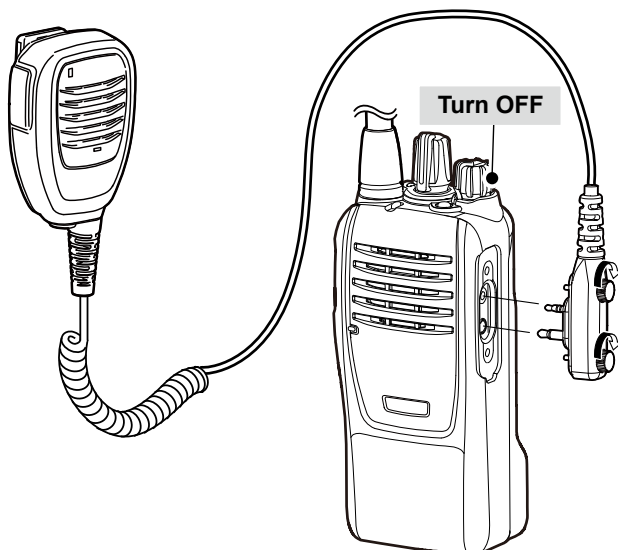

CAUTION: Firmly attach to the speaker microphone jack, but do not overtighten. A loose connection will allow water intrusion into the connector. An overtightened connection will damage the connector pins on the transceiver.

Front, top and side panels

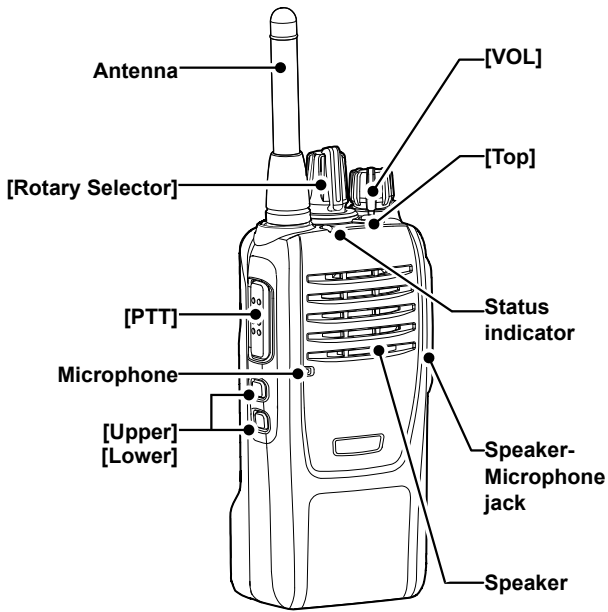

◇ Status indicator

- Lights red: Transmitting.
 - Lights green: Receiving or squelch is open.
 - Lights or blinks orange: A matching signal is received, depending on the presetting.
 - Slowly blinks green: The battery should be charged.
 - Quickly blinks green: The battery is exhausted.
- ① Refer to the Status indicator section. (pp. 5~ 6)

◇ About the Software Key functions

You can assign the functions described below to Programmable function Keys, [Upper], [Lower], and [TOP] by using the CS-F29SDR PROGRAMMING SOFTWARE (purchase separately).

The following Software keys are assigned as defaults:

	Assigned Software Key	
	Analog	Digital
[Upper]	S-Ring/C-Ring	C-Ring
[Lower]	Monitor	Monitor
[Top]	Zone/Announce	Zone/Announce

① See pages 7~9 for details.

Status indicator

The Status indicator indicates the status of various parameters of the transceiver, as described below. (Reference: R=Red, G=Green, O=Orange)

- Programming:
Blinks while reading or writing data.
 - Programming Error:
Continuously blinks green and red if programming fails.
 - Channel Error:
Continuously blinks red and orange when you select a blank channel or an unlocked channel.
 - TX Low Battery 1:
Blinks while detecting a low battery while transmitting.
 - TX Low Battery 2:
Blinks while detecting a very low battery while transmitting.
 - TX:
Lights while transmitting.
 - Bell (Blink):
Blinks about twice every second, when the preset signal* is received.
 - Bell (ON):
Blinks about once every second, when the preset signal* is received.
- * Depending on the "Bell" setting, the Status indicator blinks:
- When a Break-in is received.
 - When a Status call that includes a matching status number is received.
 - When a Call Setup is received in the dPMR operation.
- Scan:
Blinks green while scanning for a channel with a signal.
 - Low Battery 1
Blinks slowly when you should charge the battery soon.
 - Low Battery 2
Blinks fast when you should charge the battery soon.
 - RX:
Lights green while receiving a signal.

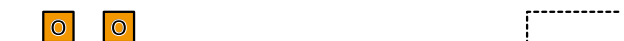

2 PANEL DESCRIPTION

Status indicator (Continued)

- **CH Access:**
Blinks orange while making a call.
- **Audible:**
Blinks orange while in the Audible mode.
- **Power ON:**
Lights orange, then blinks red, orange, and green twice at transceiver startup.
- **Success:**
Blinks orange and green repeatedly when your call was successful.
- **Failure:**
Blinks orange and red repeatedly when your call failed or it was refused.
- **TX Error:**
Blinks when transmission is inhibited (Lockout, TX Inh, or TOT Penalty timer).
- **Emergency, Siren:**
Blinks while the Alert-Ring operation, Lone Worker function or Siren function is activated.

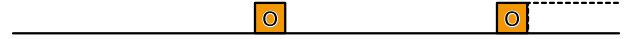
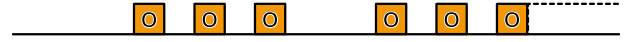

Assignable Software Key functions

You can assign the functions described below to [Top], [Upper], and [Lower] by using the CS-F29SDR PROGRAMMING SOFTWARE (purchase separately).

Category	Assignable function	Reference	Digital (dPMR446)	Analog
	Null	p. 8	✓	✓
	Clear		✓	✓
Channel / Scan	Monitor	p. 8	✓	✓
	Scan Start/Stop		✓	✓
	Zone		✓	✓
	Zone/Announce		✓	✓
Signaling / Call	A-Ring	p. 8	✓	✓
	Break		✓	N/A
	C-Ring		✓	✓
	Call		✓	N/A
	Call/C-Ring		✓	N/A
	S-Ring		N/A	✓
	S-Ring/C-Ring		N/A	✓
Functions	Announce	p. 9	✓	✓
	AquaQuake		✓	✓
	Lock		✓	✓
	Lock/A-Ring		✓	✓
	Lone Worker		✓	✓
	Siren		✓	✓
	Sp. Func 1/2		✓	✓
	Surveillance		✓	✓

✓: Applicable

N/A: Not Applicable

Assignable Software Key functions (Continued)

Null

No function.

Clear

- Push to return to the inaudible mode and automatically send a Clear Down signal. (Digital operation only)
 - ① This key is valid only in the audible mode.
- Push to return to the standby mode.

Category: Channel/Scan

Monitor

- Hold down to unmute the channel. (Audible mode)
- Push to mute the channel (Inaudible mode).
- Depending on the presetting, hold down for 1 second to cancel the scan.

NOTE: The audible (unmuted) mode may automatically return to the Inaudible (muted) mode, after the preset time period ends.

Scan Start/Stop

- Push to start or cancel a Scan.
 - ① When a scan starts with the Power ON Scan or Auto Scan function, pushing this key pauses the scan. The paused scan resumes after the preset time period has passed.
- While a scan is paused by detecting a signal, hold down for 1 second to temporarily remove the channel from the scan group. After the scan is canceled, the removed channel automatically returns to the scan group.

Zone

- Push to select a desired Zone.
- Hold down to announce the current Zone number.
 - ① The Zone number is announced when selecting a Zone, regardless of the Channel Announce setting.

TIP: What is a "Zone"?

Certain channels are grouped together and assigned to a Zone according to their intended use. For example, Analog channels 'Station 1' and 'Station 2' are assigned to an "Analog" Zone, and Digital channels 'Station 3' and 'Station 4' are assigned to a "Digital" Zone.

Zone/Announce

- Push to select a desired Zone.
- Hold down to turn the Channel Announce function ON or OFF.
 - ① The Zone number is announced when selecting a Zone, regardless of the Channel Announce setting.

Category: Signaling/Call

A-Ring

Hold down to transmit an alert signal to other stations.
① See page 13 for details

Break

The Break-in request call announces to the other stations on the channel that the user wants to break into the current communication in the group. The transceiver waits for the current communication to end and then sends a call.

- Push to send a Break-in request call.
 - ① See pages page 25 and 26 for details.

C-Ring

Hold down to make a Call-Ring call.

- The ringer sounds while holding down [C-Ring], depending on the setting.
- The same ringer sounds from your group members' speakers.

Call

Push to transmit Call Setup to Common ID.

Call/C-Ring

- Push to transmit Call Setup to Common ID.
- Hold down to make a Call-Ring call to the desired station with the ringer melodies.
 - ① You can select 16 melody patterns in the Call-Ring Pattern function.

S-Ring

A transceiver that receives a Smart-Ringer call from another transceiver sounds the Ringer melody. Also, the called transceiver sends an acknowledgment signal back to the caller transceiver.

- Push to make a Smart-Ring call.

S-Ring/C-Ring

- Hold down to make a Call-Ring call.
- Push to make a Smart-Ring call.

Assignable Software Key functions (Continued)

Category: Functions

Announce

Push to turn the Channel Announce function ON or OFF.

AquaQuake

While holding this key, the AquaQuake water draining function removes water from the speaker grill by vibrating the internal speaker.

- ① Water in the speaker grill may muffle the sound coming from the speaker.

NOTE:

- After the specified period of time, this function automatically stops, even if a user continues to hold down this key.
- This key works with only the internal speaker.

- ① You can also turn ON this function by holding down [Upper] and [Lower] when turning ON the transceiver.

Lock

Hold down for 1 second to turn the Key Lock function ON or OFF.

- ① All assignable keys except the following are electronically locked: [Lock], [Lock/A-Ring], [Lone Worker], [Monitor], [Call], [Siren], [Surveillance], [A-Ring], [Clear], [Call/C-Ring], [Sp. Func 1], [Sp. Func 2] and [PTT]. You can also make or receive calls, or turn the transceiver ON or OFF, while the Key Lock function is ON.

Lock/A-Ring

- Push to enter the Lock function.
- Hold down for 1 second to turn ON the A-Ring function.

Lone Worker

Push to turn the Lone Worker function ON or OFF.

- ① If no operation occurs during a specified period, the Lone Worker function automatically makes the transceiver enter the Alert-Ring mode.

NOTE: To use the Lone Worker function, set the related settings using the programming software.

- ① See page 13 for details.

Siren

Hold down to emit a siren sound from the speaker to let nearby people know that you are in an emergency situation.

- ① The siren will sound continuously until the transceiver is turned OFF.

Sp. Func 1, Sp. Func 2

These keys are reserved for future functions.

Surveillance

Push to turn the Surveillance function ON or OFF.

When this function is turned ON, beeps do not sound, and the status indicator does not light, even when a signal is received or a key is pushed.

Section 3 BASIC OPERATION

Turning ON the transceiver

◇ Turning ON the transceiver

NOTE: Before using the transceiver for the first time, the battery pack must be fully charged for optimum life and operation. See the BASIC MANUAL for details.

Rotate [VOL] to turn ON the transceiver.

◇ Adjusting the audio level

When receiving a call, rotate [VOL] to adjust the audio output level.

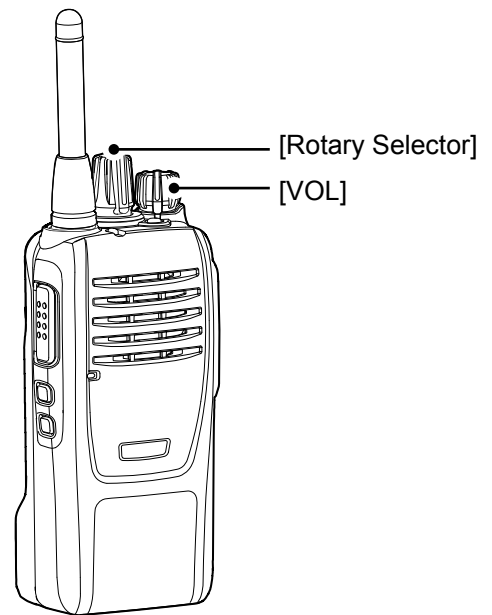

Selecting a Zone and a channel

- Push [Zone] or [Zone/Announce] to select a Zone.
 - ① When holding down [Zone] or [Zone/Announce], the selecting Zone number is announced.

TIP: What is a “Zone”?

Certain channels are grouped together and assigned to a Zone according to their intended use. For example, Analog channels ‘Station 1’ and ‘Station 2’ are assigned to an “Analog” Zone, and Digital channels ‘Station 3’ and ‘Station 4’ are assigned to a “Digital” Zone.

- Rotate [Rotary Selector] to select a channel.

Call procedure

When your system uses tone signaling, a call procedure may be necessary prior to voice transmission. The tone signaling employed may be a selective calling system, which enables you to call only specific stations, and prevents unwanted stations from contacting you.

CTCSS, DTCS, Common ID must be the same on all of your group transceiver to use tone signaling.

1. Select a channel.
① This may not be necessary, depending on the presetting.
2. Push [S-Ring], [S-Ring/C-Ring], [Call] or [Call/C-Ring].
3. After transmitting, the remainder of your communication can be carried out in the normal way.

Selective calling

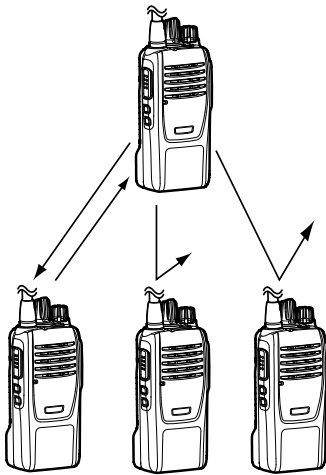

Non-selective calling

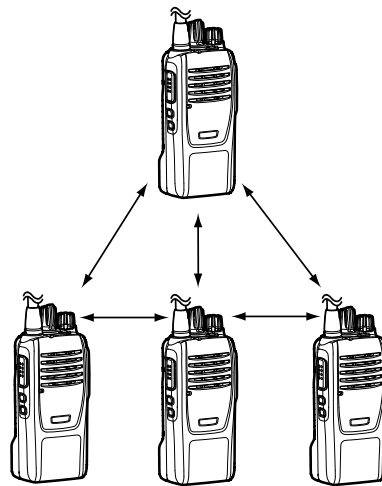

Receiving and transmitting

Receiving:

1. Turn ON the transceiver. (p. 10)
2. Select a channel.
3. When receiving a call, rotate [VOL] to adjust the audio output level to a comfortable listening level.

Transmitting:

1. Wait for the channel to become clear to avoid interference.
2. While holding down [PTT], speak at your normal voice level.
3. Release [PTT] to receive.

IMPORTANT: To maximize the readability of your signal.

1. Pause briefly after pushing [PTT].
2. Hold the microphone 5 to 10 cm from your mouth, then speak at your normal voice level.

◇ Transmitting notes

Transmit inhibit function

The transceiver has several inhibit functions which restrict transmission under the following conditions:

- The channel is in the Inaudible mode.
- The channel is busy. However, depending on the presetting, you can transmit when a call is received that includes a non-matching (or matching) CTCSS (DTCS), Common ID.
- The selected channel is a 'receive only' channel.

Time-Out Timer

If continuous transmission exceeds the preset Time-Out Timer time, transmission is cut off.

Penalty timer

After transmission is cut off by the Time-Out Timer, transmission is further inhibited for a preset penalty period of time.

Section 4 ADVANCED OPERATION

Alert-Ring call

◇ Transmitting an Alert-Ring call

Alert-Ring call can repeat Call-Ring operation to indicate an emergency situation.

If the transceiver enters the Alert-Ring mode, a countdown starts. The transceiver counts down during the Repeat Timer set time.

Before the Repeat Timer set time expires, the transceiver transmits an Alert-Ring once or repeatedly.

The transceiver enters the Alert-Ring mode through the following functions:

- ① The transceiver automatically transmits a repeat Alert-Ring call until a user turns OFF the transceiver or until holding down [A-Ring] or [Lock/A-Ring].

• The [A-Ring] key function

- Hold down [A-Ring] or [Lock/A-Ring] to enter the Alert-Ring mode.

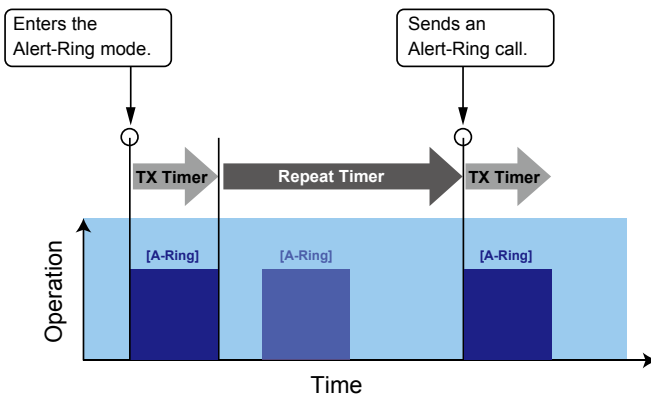

- ① If holding down [A-Ring] or [Lock/A-Ring] during the Repeat Timer, the Emergency mode is canceled.

• The Lone Worker function

If no operation occurs during a specified period, the Lone Worker function automatically makes the transceiver enter the Alert-Ring mode.

- ① When you turn the Lone Worker function ON or OFF, push [Lone Worker].

1. When no operation occurs, the ON Timer presets time.
2. When the transceiver is put into the Alert-Ring mode by the Lone Worker function, the Reminder Timer starts.
 - ① If a user pushes any key before the Reminder Timer set time expires, the Alert-Ring mode is canceled.
3. After the Reminder Timer period ends, the transceiver transmits an Alert-Ring call once or repeatedly.
4. After the TX Timer period, the count down beep automatically starts to start the Alert-Ring function.

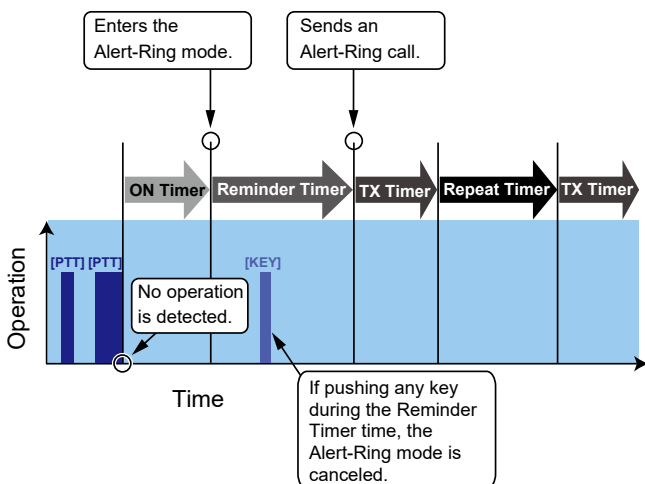

Sounding a Siren

Hold down [Siren] to emit a siren sound from the speaker to let surrounding people know that you are in an emergency situation.

The siren will continuously sound until the transceiver is turned OFF.

AquaQuake Water Draining function

By vibrating the speaker cone, the AquaQuake Water Draining function clears water from the speaker grill to maintain clear audio.

1. Hold down [AquaQuake] to turn ON the AquaQuake water draining function.

TIP: You can also turn ON this function, as shown below.

1. Rotate [VOL] to turn OFF the transceiver.
2. Set [Rotary Selector] to Channel 16.
3. While holding down [Upper] and [Lower], rotate [VOL] to turn ON the transceiver.

- A low frequency vibration is generated to remove water from the speaker grill.
- Water in the speaker grill may muffle the sound coming from the speaker.

2. Release the keys to turn OFF the function.

NOTE:

- After the specified period expires, this function automatically stops, even if a user continues to hold down these keys.
- These keys work for only the internal speaker.

Tone Scan function

This function is effective when the user wants to communicate with another station but does not know its CTCSS tone or DTCS code setting.*

* Depending on the presetting. Ask your dealer for details.

NOTE: Turn ON the Beep function (p. 16) before you enter the Tone Scan mode.

1. Rotate [VOL] to turn OFF the power.
2. Set [Rotary Selector] to any channel other than Channel 16.
3. While holding down [Upper] and [Lower], rotate [VOL] to turn ON the transceiver and enter the Tone Scan mode.
 - An opening beep sounds and the current channel number is announced. (Example: Ten)
4. Rotate [Rotary Selector] to select a desired channel that you want to assign the detected CTCSS tone or DTCS code to.
 - The selected channel number is announced.
5. Hold down [Upper] for 1 second to start a scan.
 - The status indicator blinks green slowly.
6. When detecting a matching tone or code, the scan pauses, and the tone or code is automatically set to the channel.
7. Push [Upper] to cancel the scan.

NOTE: The scan resumes 3 seconds (default) after the signal disappears.

8. Rotate [VOL] to turn OFF the transceiver and exit the Tone Scan mode.

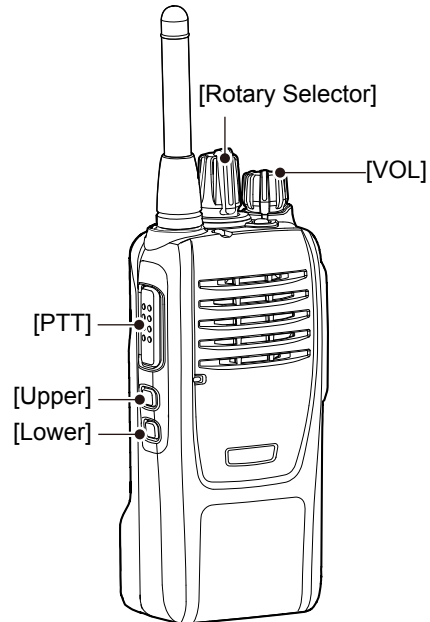

Section 5 SETTINGS

You can customize the transceiver operation to suit your preferences and operating style.

Setting the Beep function

You can turn the Beep function ON or OFF.

NOTE: Turn ON the Beep function when you set the beep and announcement level, Call-Ring ringer, ringer level, microphone gain, squelch level, VOX function, or VOX gain to check the current level setting by counting or hearing beeps. (pp. 17 ~ 24)

1. Rotate [VOL] to turn OFF the transceiver.
2. Set [Rotary Selector] to any channel other than Channel 16.
3. While holding down [Lower], rotate [VOL] to turn ON the transceiver to enter the Beep Level Adjustment mode.
 - An opening beep sounds and the selected channel number will be announced.
4. Push [Lower] to turn the Beep function ON or OFF.
 - When a beep sounds after pushing [Lower], the Beep function is ON.
 - When no beep sounds after pushing [Lower], the Beep function is OFF.
 - ① The transceiver stores the setting every time you change it.
 - ① If desired, push [Upper] to adjust the beep level. See page 17 for details.
5. Rotate [VOL] to turn OFF the transceiver and exit the Beep Level Adjustment mode.

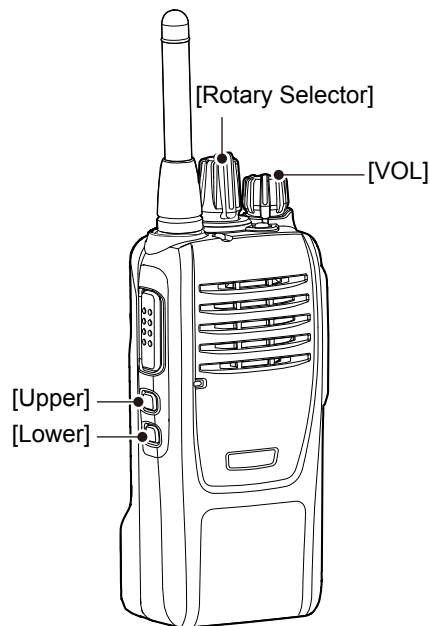

Setting the beep and announcement level

You can adjust the beep and announcement level between 1 and 5, or 1 (linked) and 5 (linked). When a linked option is selected, the beep audio level is adjustable by rotating [VOL].

NOTE: Turn ON the Beep function (p. 16) before you start setting the beep and announcement level.

1. Rotate [VOL] to turn OFF the transceiver.
2. Set [Rotary Selector] to any channel other than Channel 16.
3. While holding down [Lower], rotate [VOL] to turn ON the transceiver and enter the Beep Level Adjustment mode.
 - An opening beep sounds and the selected channel number will be announced.
4. Push [Upper] to change the beep level.
 - A beep sounds every time you push [Upper]. Therefore, you can determine the current level setting by the increasing loudness of the beep that sounds.

① Information

- The adjustable range is 1 to 5 or 1 (Linked) to 5 (Linked).
 - Repeatedly pushing [Upper] first selects 1 (lowest) to 5 (highest), and then selects the lowest linked level, 1 (Linked) to the highest, 5 (Linked). Repeatedly pushing [Upper] repeats the cycle. See the illustration to the right.
 - To determine if you have selected a linked level, set [VOL] to a minimum, then push [Upper] repeatedly, listening for the loudest beep (level 5). Pushing [Upper] once after the loudest beep will select 1 (Linked). Repeatedly push [Upper] to select the desired linked level.
5. Rotate [VOL] to turn OFF the transceiver and exit the Beep Level Adjustment mode.

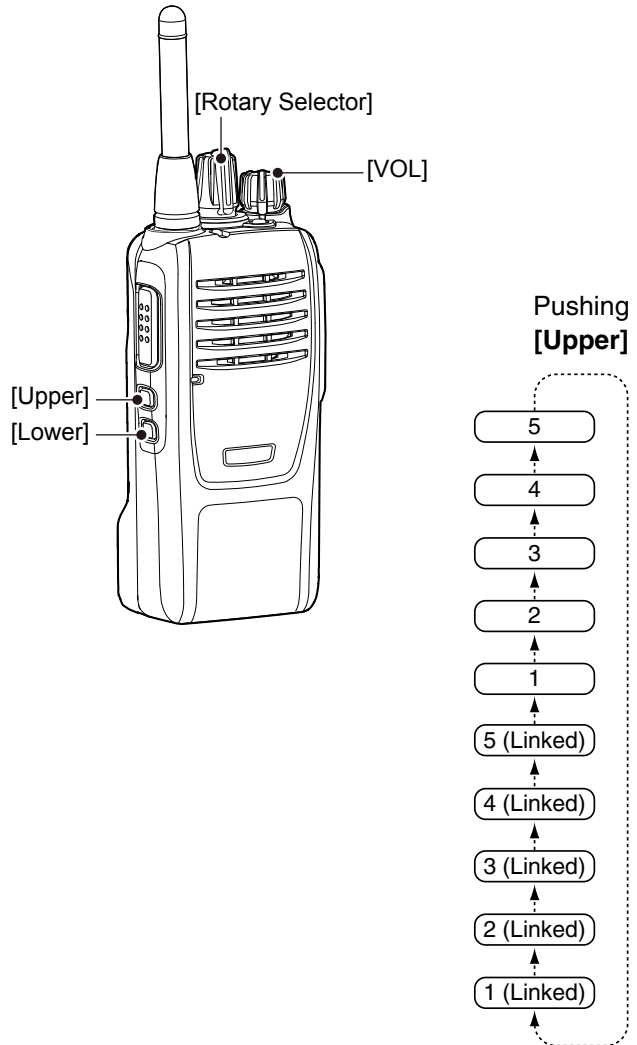

Setting the Call-Ring pattern

The Call-Ring ringer sounds only when the user holds down [C-Ring], [Call/C-Ring], [S-Ring/C-Ring] to make a call.

NOTE: Turn ON the Beep function (p. 16) before you start setting the Call-Ring ringer.

1. Rotate [VOL] to turn OFF the transceiver.
2. Set [Rotary Selector] to any channel other than Channel 16.
3. While holding down [PTT] and [Lower], rotate [VOL] to turn ON the transceiver and enter the Call-Ring pattern Setting mode.
 - The current Call-Ring ringer sounds.
4. Rotate [Rotary Selector] to select a desired Call-Ring pattern.
 - The selected Call-Ring ringer sounds.
5. Rotate [VOL] to turn OFF the transceiver and exit the Call-Ring pattern Setting mode.

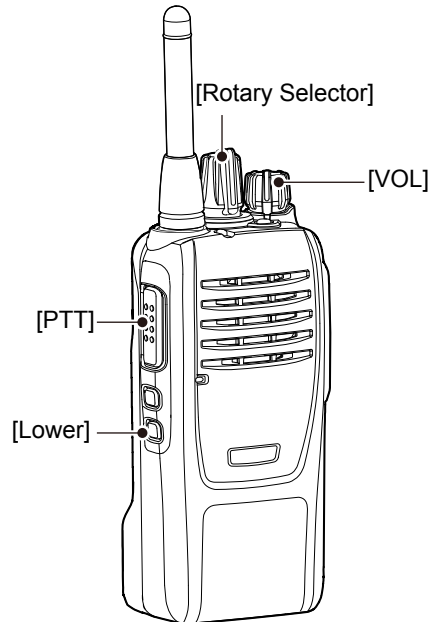

Setting the ringer level

You can adjust the ringer level between 1 and 5, or 1 (Linked) and 5 (Linked). When a linked option is selected, the ringer audio level is adjustable by rotating [VOL].

NOTE: Turn ON the Beep function (p. 16) before you start setting the ringer level.

1. Rotate [VOL] to turn OFF the transceiver.
2. Set [Rotary Selector] to Channel 16.
3. While holding down [Lower], rotate [VOL] to turn ON the transceiver and enter the Ringer Level Adjustment mode.
 - An opening beep sounds and “Sixteen” will be announced.
4. Push [Upper] to increase, or push [Lower] to decrease the ringer level.
 - A beep sounds after pushing [Upper] or [Lower]. Therefore, you can determine the current level setting by the increasing or decreasing loudness of the beep that sounds.

Information

- The adjustable range is 1 to 5 or 1 (Linked) to 5 (Linked).
 - Repeatedly pushing [Upper] first selects 1 (lowest) to 5 (highest), and then selects the lowest linked level, 1 (Linked) to the highest, 5 (Linked). Repeatedly pushing [Upper] or [Lower] repeats the cycle. See the illustration to the right.
 - To determine if you have selected a linked level, set [VOL] to a minimum, then push [Upper] up to 10 times, listening for the loudest beep (level 5). Pushing [Upper] once after the loudest beep will select 1 (Linked). Repeatedly push [Upper] or [Lower] to select the desired linked level.
5. Rotate [VOL] to turn OFF the transceiver and exit the Ringer Level Adjustment mode.

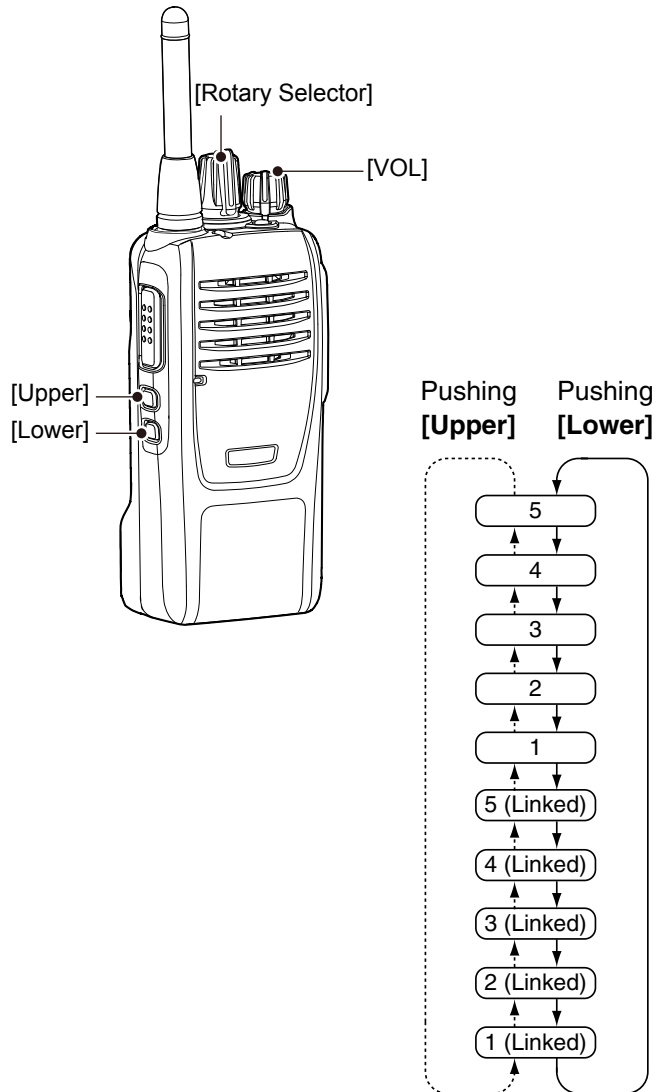

Setting the microphone gain

You can adjust the microphone gain. Higher values make the microphone more sensitive to the user's voice.

NOTE: Turn ON the Beep function (p. 16) before you start setting the microphone gain.

1. Rotate [VOL] to turn OFF the transceiver.
2. Set [Rotary Selector] to Channel 16.
3. While holding down [Upper], rotate [VOL] to turn ON the transceiver and enter the Microphone Gain Adjustment mode.
 - An opening beep sounds and "Sixteen" is announced.
4. Push [Upper] to increase, or push [Lower] to decrease the microphone gain.
 - A beep sounds after pushing [Upper] or [Lower].
 - An error beep sounds if you try to exceed the adjustable range.
 - ① The adjustable range is 1 (minimum) to 4 (maximum).
5. Rotate [VOL] to turn OFF the transceiver and exit the Microphone Gain Adjustment mode.

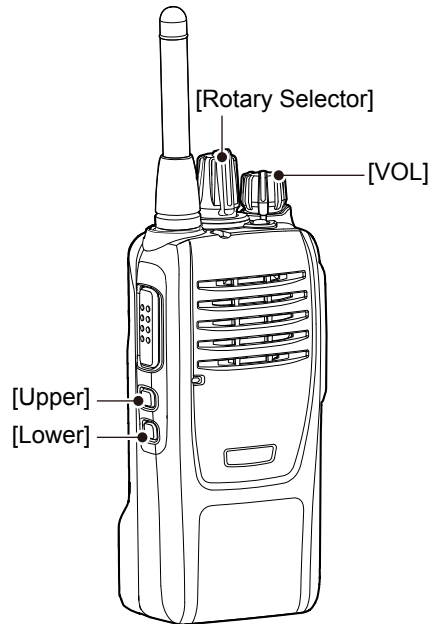

Setting the squelch level

You can adjust the squelch level. The squelch circuit mutes the received audio or noise signal, depending on the signal strength.

NOTE: Turn ON the Beep function (p. 16) before you start setting the squelch level.

1. Rotate [VOL] to turn OFF the transceiver.
2. Set [Rotary Selector] to any channel other than Channel 16.
3. While holding down [Upper], rotate [VOL] to turn ON the transceiver and enter the Squelch Level Adjustment mode.
 - An opening beep sounds and the selected channel number will be announced.
4. Push [Upper] to increase the squelch level (tight squelch), or push [Lower] to decrease the squelch level (loose squelch).
 - A beep sounds after pushing [Upper] or [Lower]. An error beep sounds if you try to exceed the adjustable range.
 - ① The adjustable range is 0 (loose squelch) to 9 (tight squelch).
5. Rotate [VOL] to turn OFF the transceiver and exit the Squelch Level Adjustment mode.

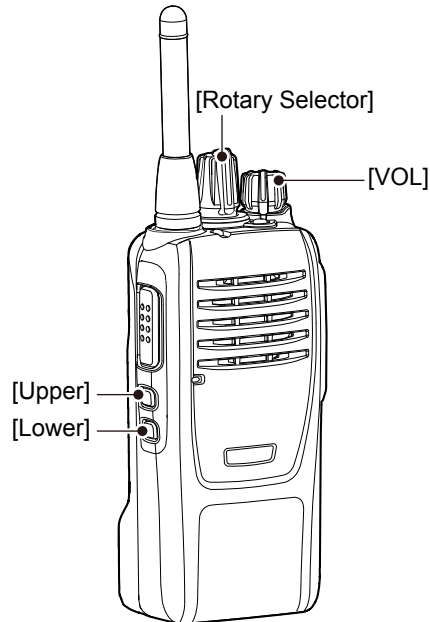

Setting the VOX function

You can turn the VOX function ON or OFF. The VOX function automatically switches between receive and transmit using your voice.

NOTE:

- To use the function, a headset and a VOX converter cable are required (purchase separately).
- Turn ON the Beep function (p. 16) before setting the VOX function.

1. Rotate [VOL] to turn OFF the transceiver.
2. Set [Rotary Selector] to any channel other than Channel 16.
3. While holding down [PTT] and [Upper], rotate [VOL] to turn ON the transceiver, to turn the VOX function ON or OFF.
 - When the VOX function is turned OFF, an opening beep and a beep sound, and the selected channel number is announced.
 - When the VOX function is turned ON, an opening beep and two beeps sound, and the selected channel number is announced.
4. Rotate [VOL] to turn OFF the transceiver, then turn ON again to restart normal operation.

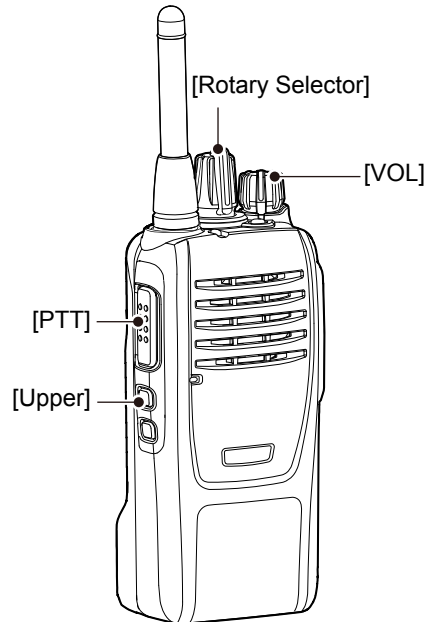

Setting the VOX gain

You can adjust the VOX gain. Higher values make the VOX function more sensitive to the user's voice.

NOTE: Turn ON the Beep function (p. 16) before you start setting the VOX gain.

1. Rotate [VOL] to turn OFF the transceiver.
2. Set [Rotary Selector] to Channel 16.
3. While holding down [PTT] and [Upper], rotate [VOL] to turn ON the transceiver and enter the VOX Gain Adjustment mode.
 - An opening beep sounds and "Sixteen" is announced.
4. Push [Upper] to increase, or push [Lower] to decrease the VOX gain.
 - A beep sounds after pushing [Upper] or [Lower].
 - An error beep sounds if you try to exceed the adjustable range.
 - ① The adjustable range is 1 (minimum) to 10 (maximum).
5. Rotate [VOL] to turn OFF the transceiver and exit the VOX Gain Adjustment mode.

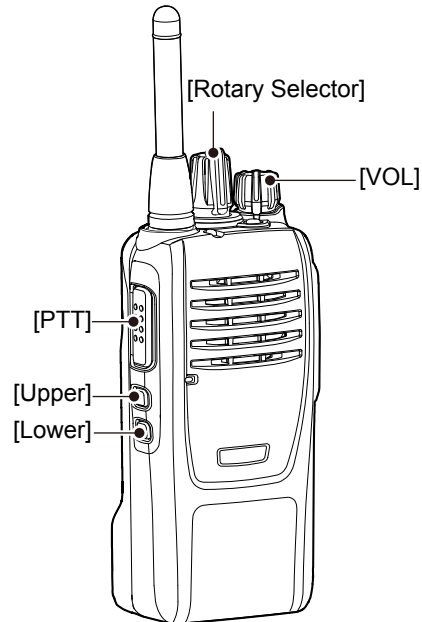

Setting a scan type

You can set whether the transceiver scans all channels across the zone (All) or scans channels in a selected zone (Zone).

NOTE: Turn ON the Beep function (p. 16) before you start setting a scan type.

◇ Scan types

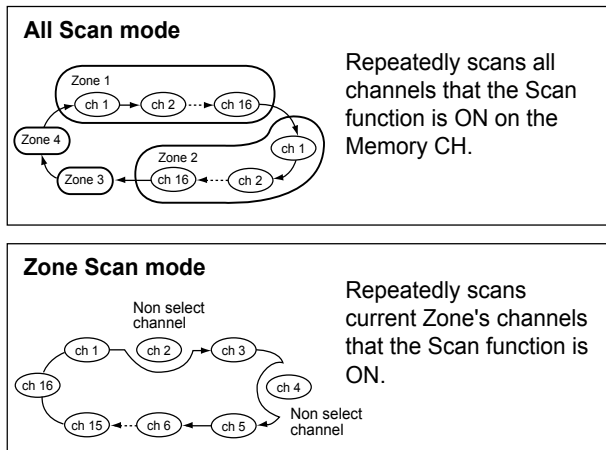

1. Rotate [VOL] to turn OFF the transceiver.
2. Set [Rotary Selector] to Channel 16.
3. While holding down [PTT], rotate [VOL] to turn ON the transceiver to set a scan type and confirm the number of beeps.
 - If you want to set to "All," confirm a beep and an opening beep sound when you do step 3. If 2 beeps and an opening beep sound, turn OFF the transceiver, then do step 3 again.
 - If you want to set it to "Zone," confirm 2 beeps and an opening beep sound when you do step 3. If a beep and an opening beep sound, turn OFF the transceiver, then do step 3 again.
4. Rotate [VOL] to turn OFF the transceiver, then turn it ON again to save the setting. To start a scan, push the key assigned to the Scan function.

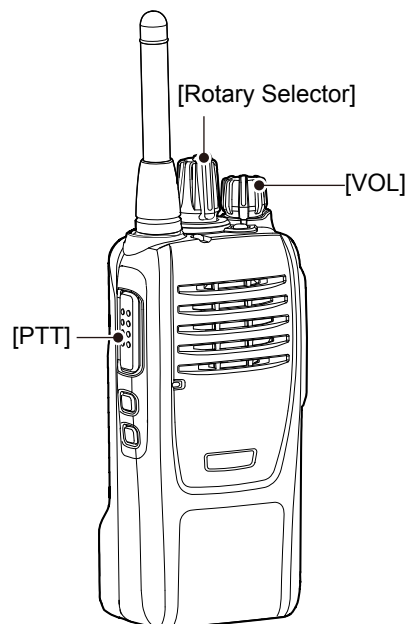

Section 6 dPMR OPERATION

The IC-F29DR3 can be used in both digital and analog modes.
In the digital mode, digital call, RX Status, Break-in request, and Alert-Ring functions are supported.

Receiving a call

◇ Receiving a call

When a call is received:

- Mute is released.
 - The Status indicator lights green.
1. Hold down [PTT] to speak.
 2. Release [PTT] to receive.

◇ Receiving a Status call

When receiving a Status call, the ringer sounds and the Status indicator blinks, depending on the presetting.
Ask your dealer for details.

NOTE: You cannot send a Status call with the IC-F29DR3.

◇ Receiving a Break-in request call

When a Break-in call is received:

- The Status indicator lights green.
 - The ringer sounds.
- ① Push any key to stop sounding the ringer and blinking the Status indicator.

TIP: What is a Break-in call?

The Break-in request call announces to the other stations on the channel that the user wants to break into the current communication in the group.

The transceiver waits for the current communication to end, and then sends the call.

Example: Station A, B, and C communicate using the same Common ID.

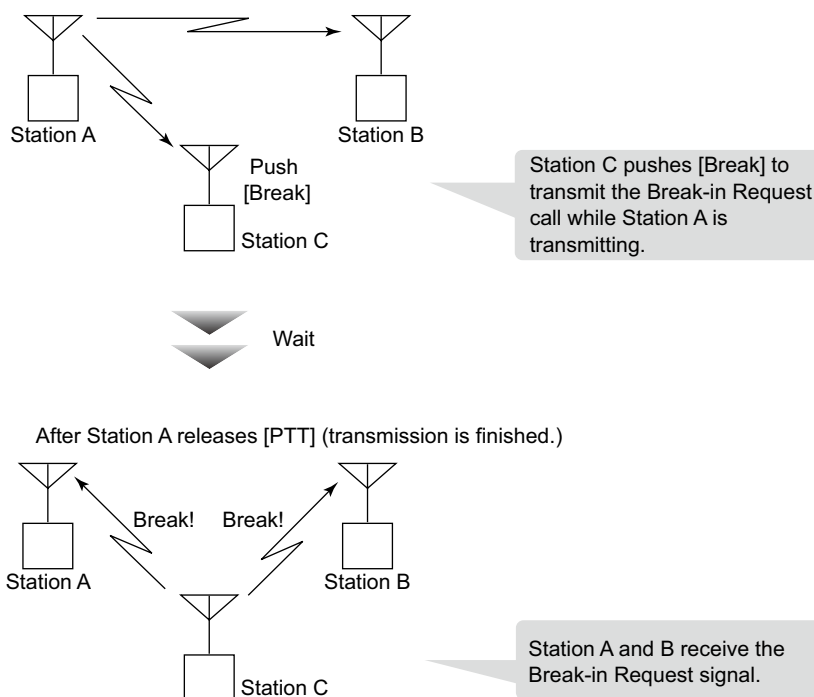

Transmitting a call

You can make a call to a station that has the same Common ID. Other digital mode transceivers on the channel will not receive a call that does not match their Common ID.

Before making a call, wait until the channel is clear to avoid interference.

◇ General

The target ID (Common ID) is preset to a channel. To make a call, you should select the desired channel that your target station is set to.

◇ Transmitting a call

<Using [PTT]>

1. Rotate [Rotary Selector] to select a channel.
2. Push [PTT] to transmit a call.
3. Hold down [PTT] to speak.
4. Release [PTT] to receive.
5. Push [Clear] to send a 'Disconnect' signal to terminate the call.

<Using the C-Ring function>

1. Rotate [Rotary Selector] to select a channel.
2. Holding down [C-Ring], [Call/C-Ring] or [S-Ring/C-Ring] while transmitting.
3. Hold down [PTT] to speak.
4. Release [PTT] to receive.
5. Push [Clear] to send a 'Disconnect' signal to terminate the call.

<Using the Call function>

1. Rotate [Rotary Selector] to select a channel.
2. Push [Call] or [Call/C-Ring] to send a call request.

NOTE: After receiving a call request, a ringer sounds on a receiving transceiver.

3. Hold down [PTT] to speak.
4. Release [PTT] to receive.
5. Push [Clear] to send a 'Disconnect' signal to terminate the call.

◇ Transmitting a Break-in Request call

1. While receiving a signal, push [Break].
 - Pushing [Clear] or [Break] to cancel the call.
2. When the received signal disappears, the Break-in Request call is automatically transmitted.
 - The Status indicator blinks orange and green repeatedly when the Break-in Request call is successful.
3. Push and hold [PTT], then speak into the microphone at your normal voice level.

◇ Transmitting an Alert-Ring call

See "Alert-Ring call" for details (p. 13).

