



OPERATING GUIDE

dPMR446/PMR446 TRANSCEIVER
IC-F29SDR

INTRODUCTION

1 ACCESSORIES

2 PANEL DESCRIPTION

3 BASIC OPERATION

4 ADVANCED OPERATION

5 USER SET MODE

6 dPMR™ OPERATION

INTRODUCTION

Thank you for choosing this Icom product. This product was designed and built with Icom's state of the art technology and craftsmanship. With proper care, this product should provide you with years of trouble-free operation.

IMPORTANT

FIRST, CAREFULLY READ INSTRUCTIONS that is provided with the transceiver.

SAVE THIS OPERATING GUIDE— This operating guide contains additional important operating instructions for the following transceivers.

Icom, Icom Inc. and Icom logo are registered trademarks of Icom Incorporated (Japan) in Japan, the United States, the United Kingdom, Germany, France, Spain, Russia, Australia, New Zealand, and/or other countries.
AquaQuake is a trademark of Icom Incorporated.
dPMR and the dPMR logo are trademarks of the dPMR MoU Association.
All other products or brands are registered trademarks or trademarks of their respective holders.

Icom is not responsible for the destruction, damage to, or performance of any Icom or non-Icom equipment, if the malfunction is because of:

- Force majeure, including, but not limited to, fires, earthquakes, storms, floods, lightning, other natural disasters, disturbances, riots, war, or radioactive contamination.
- The use of Icom transceivers with any equipment that is not manufactured or approved by Icom.

Section 1 ACCESSORIES

Attaching or detaching accessories.....	1-2
◇ Battery pack.....	1-2
◇ Belt clip.....	1-2
◇ Jack cover.....	1-3

Attaching or detaching accessories

◇ Battery pack

Attaching:

1. Slide the battery pack in the direction of the arrow. (1)
2. Push the battery pack until the battery sliding locks make a 'click' sound. (2)

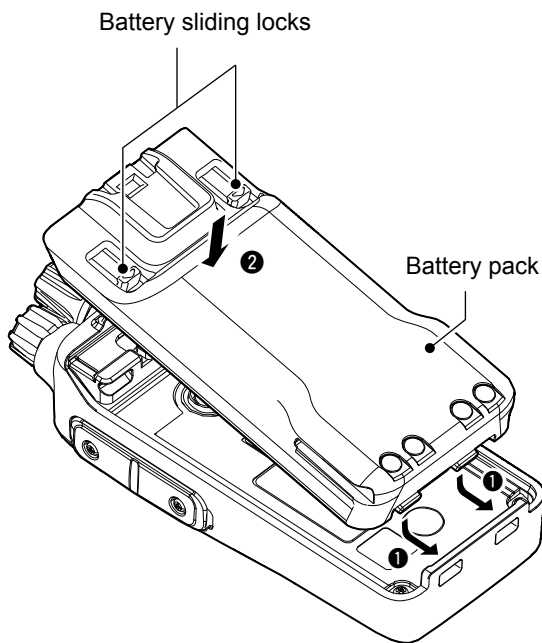

Detaching:

1. Pull both battery sliding locks in the direction of the arrow. (1)
 - The battery pack is then released.
2. Lift up to detach the battery pack. (2)

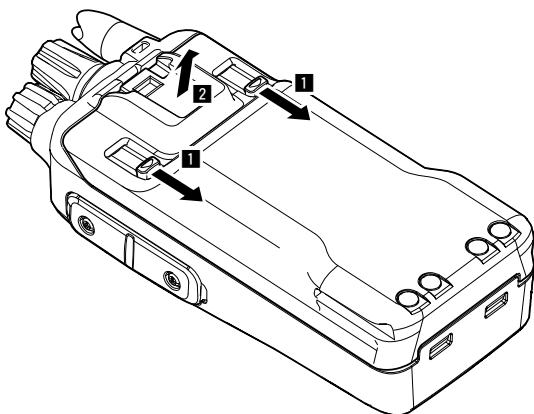

◇ Belt clip

Attaching:

1. Remove the battery pack from the transceiver, if it is attached.
2. Slide the belt clip in the direction of the arrow until the belt clip is locked and makes a 'click' sound.

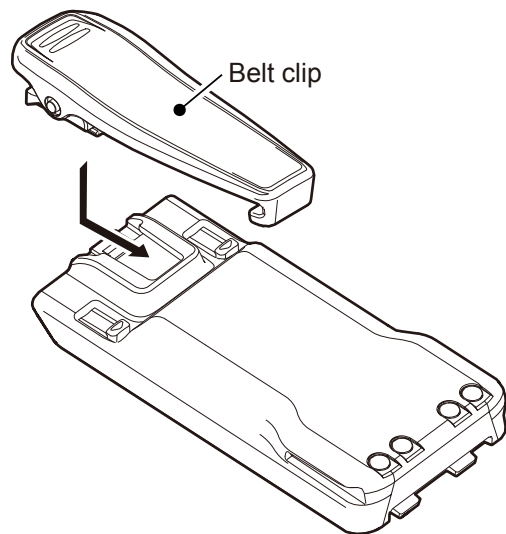

Detaching:

- Lift the tab up (1), and slide the belt clip in the direction of the arrow. (2)

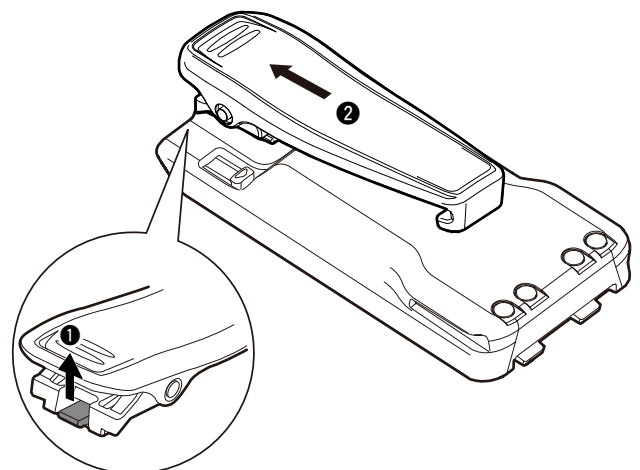

BE CAREFUL! DO NOT break your fingernail.

Attaching or detaching accessories

◇ Jack cover

CAUTION: DO NOT use the transceiver without the connector cover or optional equipment attached. The transceiver meets IP67/IP55/IP54 requirements for dust-tight and waterproof protection only when the connector cover or the HM-168LWP, HS-94LWP, or HS-95LWP is attached.

Attaching:

1. Place the jack cover over the speaker-microphone jack. (1)
2. Insert and tighten the screws. (2)

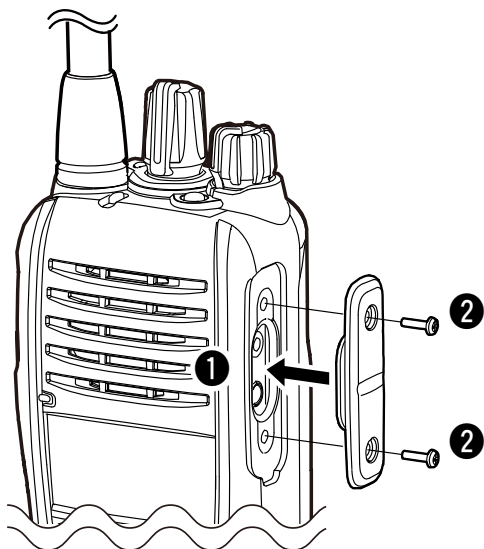

Detaching:

1. Unscrew the screws using a Phillips screwdriver. (1)
2. Detach the jack cover. (2)

CAUTION: DO NOT detach the jack cover when optional equipment is going to be used. Otherwise the terminals of the speaker microphone jack may be shorted by a metal object, or become rusty by water intrusion. This could damage the transceiver.

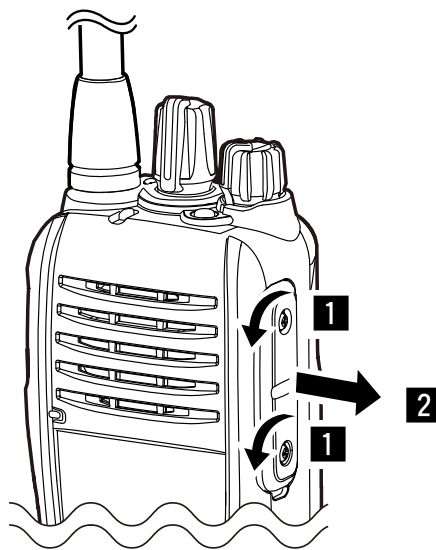

Section 2

PANEL DESCRIPTION

Front, top and side panels	2-2
◇ Status indicator	2-2
◇ About the Software Key functions.....	2-2
Function display.....	2-3
Status indicator.....	2-4
Assignable Software Key functions	2-6

Front, top and side panels

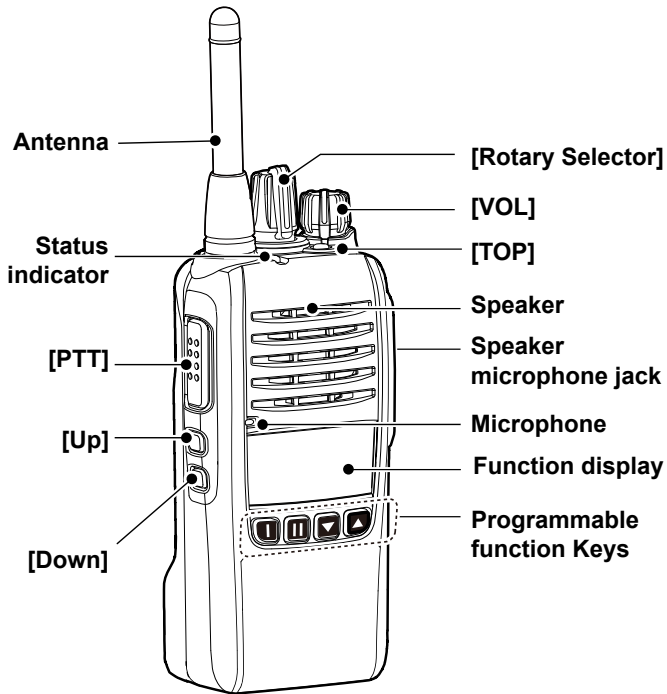

◇ Status indicator

- Lights red: Transmitting.
 - Lights green: Receiving or squelch is open.
 - Lights or blinks orange: A matching signal is received, depending on the presetting.
 - Slowly blinks green: The battery should be charged.
 - Quickly blinks green: The battery is exhausted.
- ① Refer to the Status indicator section.(pp.2-4 ~2-5)

◇ About the Software Key functions

You can assign the functions described below to Programmable function Keys, [Up], [Down], and [TOP] by using the CS-F29SDR PROGRAMMING SOFTWARE (purchase separately).

The following Software keys are assigned as defaults:

	Assigned Software Key	
	Analog	Digital
	Monitor	Clear
	S-Ring/C-Ring	Call/C-Ring
	CH Down/Zone Down	CH Down/Zone Down
	CH Up/Zone Up	CH Up/Zone Up
[Up]	Code	Code/Select
[Down]	Lock/Favorite CH Rewrite	Lock/Favorite CH Rewrite
[Top]	A-Ring	A-Ring

Function display

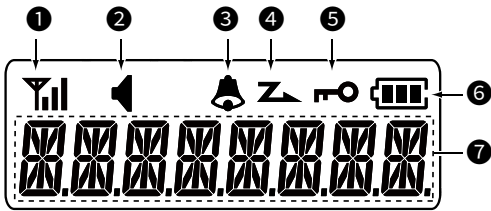

- 1 SIGNAL STRENGTH INDICATOR** 

Displays the relative receive signal strength level.
- 2 AUDIBLE ICON** 

Displayed when the channel is in the 'Audible' (unmuted) mode.
- 3 BELL ICON** 





Displayed when a matching signal is received, depending on the presetting.
- 4 SCAN ICON** 

Displayed or blinks while scanning.
- 5 KEY LOCK ICON** 

Displayed when the Key Lock function is ON.

- 6 BATTERY INDICATOR**

Displays the remaining battery charge.

Indication				
Battery Status	Full	Mid	Charging required	Battery exhausted

 blinks when the battery is exhausted.

- 7 ALPHANUMERIC READOUT**

Displays the selected Zone number, channel number, and, if entered, the channel name.

Status indicator

The Status indicator indicates the status of various parameters of the transceiver, as described below. (Reference: R=Red, G=Green, O=Orange)

- Programming:
Blinks while reading or writing data.
 - Programming Error:
Continuously blinks green and red if programming fails.
 - Channel Error:
Continuously blinks red and orange when you select a blank channel, or an unlocked channel.
 - TX Low Battery 1:
Blinks while detecting a low battery while transmitting.
 - TX Low Battery 2:
Blinks while detecting a very low battery while transmitting.
 - TX:
Lights while transmitting.
 - Bell (Blink):
Blinks about twice every second, when the preset signal* is received.
 - Bell (ON):
Blinks about once every second, when the preset signal* is received.
- * Depending on the "Bell" setting, the Status indicator blinks:
- When a Break-in is received.
 - When a Status call that includes a matching status number is received.
 - When a Call Setup is received in the dPMR™ operation.
- Scan:
Blinks green while scanning for a channel with a signal.
 - Low Battery 1
Blinks slowly when you should charge the battery soon.
 - Low Battery 2
Blinks fast when you should charge the battery soon.
 - RX:
Lights green while receiving a signal.



2 PANEL DESCRIPTION

Status indicator (Continued)

- **CH Access:**
Blinks orange while making a call.
- **Audible:**
Blinks orange while in the Audible mode.
- **Power ON:**
Lights orange, then blinks red, orange, and green twice at transceiver startup.
- **Success:**
Blinks orange and green repeatedly when your call was successful.
- **Failure:**
Blinks orange and red repeatedly when your call failed, or it was refused.
- **TX Error:**
Blinks when transmission is inhibited (Lockout, TX Inh, or TOT Penalty timer).
- **Emergency, Siren:**
Blinks while the Alert-Ring operation, Lone Worker function, or Siren function is activated.

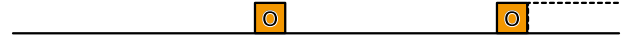

Assignable Software Key functions

Category	Assignable function	Reference	Digital (dPMR446)	Analog
	Null	p. 2-7	✓	✓
	Clear	p. 2-7	✓	✓
Channel / Scan	Auto CH	p. 2-7	✓	✓
	CH Up, CH Down	p. 2-7	✓	✓
	CH Up/Zone UP CH Down/Zone Down	p. 2-7	✓	✓
	Favorite CH Rewrite	p. 2-7	✓	✓
	Monitor	p. 2-7	✓	✓
	Scan Start/Stop	p. 2-7	✓	✓
	Signaling / Call	A-Ring	p. 2-8	✓
Break		p. 2-8	✓	N/A
C-Ring		p. 2-8	✓	✓
Call		p. 2-8	✓	N/A
Call/C-Ring		p. 2-8	✓	N/A
Code		p. 2-8	✓	✓
Code/Select		p. 2-8	✓	N/A
S-Ring		p. 2-8	N/A	✓
S-Ring/C-Ring		p. 2-8	N/A	✓
Select		p. 2-8	✓	N/A
Functions	Announce	p. 2-9	✓	✓
	AquaQuake	p. 2-9	✓	✓
	Light	p. 2-9	✓	✓
	Lock	p. 2-9	✓	✓
	Lock/A-ring	p. 2-9	✓	✓
	Lock/Favorite CH Rewrite	p. 2-9	✓	✓
	Lone Worker	p. 2-9	✓	✓
	My Name	p. 2-9	✓	✓
	Siren	p. 2-9	✓	✓
	Sp. Func 1/2	p. 2-9	✓	✓
	Surveillance	p. 2-9	✓	✓
	User Set Mode	p. 2-9	✓	✓

✓: Applicable

N/A: Not Applicable

Assignable Software Key functions (Continued)

Null

No function.

Clear

- Push to return to the inaudible mode and automatically send a Clear Down signal. (Digital operation only)
① This key is valid only in the audible mode.
- Push to return to the standby mode when the application selection mode menu is displayed.

Category: Channel/Scan

Auto CH

- Push to automatically search a clear channel during.

CH Up, CH Down

- Push to select an operating channel.
- After pushing a Software Key, push to select an option, setting, and so on.
- Push to select an option setting after pushing a programmable Key.

CH Up/Zone Up, CH Down/Zone Down

- Push to select a Memory channel, while in the Standby mode.
- Hold down for 1 second to select a Zone, while in the Standby mode.

TIP: What is a “Zone”?

Certain channels are grouped together and assigned to a Zone according to their intended use. For example, Analog channels ‘Station 1’ and ‘Station 2’ are assigned to an “Analog” Zone, and Digital channels ‘Station 3’ and ‘Station 4’ are assigned to a “Digital” Zone.

Favorite CH Rewrite

Hold down for 1 second to update the Favorite channel.
① See page 3-3 for details.

Monitor

- Hold down to unmute the channel. (Audible mode)
- Push to enter the Inaudible mode.
- Activates the following function on each channel, depending on the presetting.
- Depending on the presetting, hold down for 1 second to cancel the scan.

NOTE: The audible (unmuted) mode may automatically return to the Inaudible (muted) mode, after the preset time period ends.

Scan Start/Stop

- Push to start or cancel a Scan.
① When a scan started with the Power ON Scan or Auto Scan function, pushing this key pauses the scan. The paused scan resumes after the preset time period has passed.
- While a scan is paused by detecting a signal, hold down for 1 second to temporarily remove the channel from the scan group. After the scan is canceled, the removed channel automatically returns to the scan group.

Assignable Software Key functions (Continued)

Category: Signaling/Call

A-Ring

Hold down to transmits the alert signal to other stations.

- “ALERT” is displayed.
- ① See page 4-2 for details

Break

The Break-in request call announces to the other stations on the channel that the user wants to break into the current communication in the group. The transceiver waits for the current communication to end, and then sends the call.

- Push to send a Break-in request call.
- ① See pages 6-3 and 6-4 for details.

C-Ring

Hold down to make a Call-Ring call.

- The ringer sounds while holding down [C-Ring], depending on the setting.
- The same ringer sounds from your group members’ speakers.

Call

- Push to transmit the Call Setup to Common ID.
- Push to transmit the Status to Common ID.

Call/C-Ring

- Push to enter the Call function.
- Hold down to make a Call-Ring call to the desired station with the ringer melodies.
 - ① You can select the 16 types of the melody patterns in the Call-Ring Pattern function.

Code

In the Analog mode

1. Push to enter the CTCSS tone and DTCS code Selection mode.
 2. Then push [CH Up], [CH Down], [CH Up/Zone Up], or [CH Down/Zone Down] to select a CTCSS tone or DTCS code.
 3. After selecting, push this key again to set.
- Hold down for 1 second to start the Find Tone Select function to scan for the CTCSS tone and the DTCS code.

In the Digital mode

1. Push to select the Common ID Selection mode.
2. Push [CH Up], [CH Down], [CH Up/Zone Up], or [CH Down/Zone Down] to select a desired Common ID.
3. After selecting, push this key again to set.

Code/Select

- Push to enter the Code Select mode which is the Common ID for the Digital mode.
- Hold down for 1 second to turn the Status Select mode from the TX Status function for the Digital mode.

S-Ring

A transceiver that receives a Smart-Ringer call from another transceiver sounds the Ringer melody. Also, the called transceiver sends an acknowledgment signal back to caller transceiver.

- Push to make a Smart-Ring call.

S-Ring/C-Ring

- Hold down to make a Call-Ring call.
- Push to make a Smart-Ring call.

Select

- Push to select the TX Status Message in the Standby mode.
 - ① You can select a Status Message as described below.
 1. Pushing [Select] to display the Status Message Selection screen, and then select a Status Message using [CH Up], [CH Down], [CH Up/Zone Up], [CH Down/Zone Down].
 2. Selects the desired Status Message then push [Call] to transmit a call.

Assignable Software Key functions (Continued)

Category: Functions

Announce

Push to turn the Channel Announce function ON or OFF.

- ① You can also turn ON this function by holding down [0] when you turn ON the transceiver.

AquaQuake™

While holding down this key, the AquaQuake water draining function removes water from the speaker grill by vibrating the internal speaker.

- ① Water in the speaker grill may muffle the sound coming from the speaker.

NOTE:

- After the specified period of time, this function automatically stops, even if a user continues to hold down this key.
- This key works with only the internal speaker.

- ① You can also turn ON this function by holding down [Up] and [0] when you turn ON the transceiver.

Light

Push to turn ON the backlight for about 5 seconds, even if the backlight setting is OFF.

Lock

Hold down for 1 second to turn the Key Lock function ON or OFF.

- ① All assignable keys except the following are electronically locked: [Lock], [Lock/A-Ring], [Lock/Favorite CH Rewrite], [Lone Worker], [Monitor], [Call], [Light], [Siren], [Surveillance], [A-Ring], [Clear], [Call/C-Ring], [Sp. Func 1], [Sp. Func 2] and [PTT]. You can also make or receive calls, or turn the transceiver ON or OFF, while the Key Lock function is ON.
- ① When the Lock function is ON, the Lock icon is displayed.

Lock/A-Ring

- Push to enter the Lock function.
- Hold down for 1 second to turn the A-Ring function.

Lock/Favorite CH Rewrite

- Push to enter the Lock function.
- Hold down for 1 second to turn ON the Favorite CH Rewrite function.

Lone Worker

Push to turn the Lone Worker function ON or OFF.

- ① If no operation occurs during a specified period, the Lone Worker function automatically makes the transceiver enter the Alert-Ring mode.

NOTE: To use the Lone Worker function, set the related settings using the programming software.

- ① See page 4-2 for details.

My Name

Push to display the programmed "My Name."

Siren

Hold down to emit a siren sound from the speaker to let surrounding people know that you are in an Emergency situation.

- ① The siren will sound continuously until the transceiver is turned OFF.

Sp. Func 1, Sp. Func 2

Sp. Func 1 and Sp. Func 2 are reserved for PC commands.

Surveillance

Push to turn the Surveillance function ON or OFF. When this function is turned ON, beeps do not sound, and the backlight and the status indicator do not light, even when a signal is received, or a key is pushed.

User Set Mode

- Hold down for 1 second to enter the User Set mode. The User Set mode is used to change settings, without using a PC.
 - ① Hold down for 1 second again to exit the User Set mode.
- In the User Set mode, momentarily push this key to select an item, and then push [CH Up], [CH Down], [CH Up/Zone Up], or [CH Down/Zone Down] to change the value or setting.

NOTE: To use the [User Set Mode] and [CH Up], [CH Down], [CH Up/Zone Up], or [CH Down/Zone Down] must be assigned to assignable keys using the programming software.

Section 3

BASIC OPERATION

Turning ON the transceiver	3-2
◇ Turning ON the transceiver	3-2
◇ Adjusting the audio level	3-2
◇ Entering the password	3-2
Selecting a Zone.....	3-3
◇ Selecting a Zone	3-3
Selecting a channel	3-3
◇ Selecting an operating channel	3-3
◇ Favorite CH function	3-3
Call procedure	3-4
Receiving and transmitting	3-5
◇ Transmitting notes	3-5

Turning ON the transceiver

◇ Turning ON the transceiver

NOTE: Before using the transceiver for the first time, the battery pack must be fully charged for optimum life and operation. See the BASIC MANUAL for details.

Rotate [VOL] to turn ON the transceiver.

- The battery voltage or the opening text may be displayed, depending on the presetting.

◇ Adjusting the audio level

When receiving a call, rotate [VOL] to adjust the audio output level.

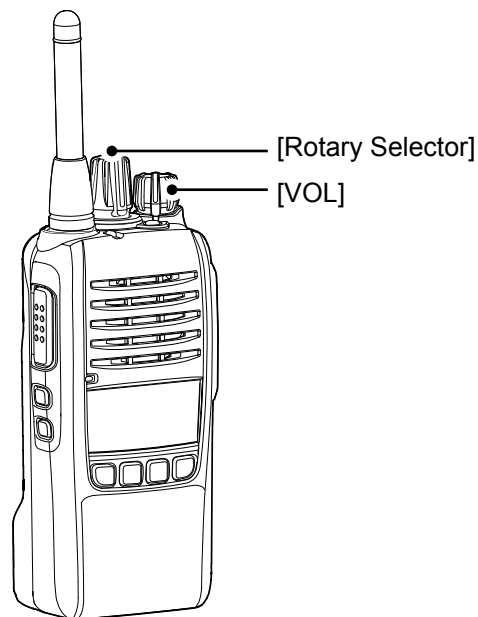

◇ Entering the password

If the transceiver is preset for a Power ON Password, "PASSWORD" is displayed when turning ON the transceiver.

In that case, enter the password.

1. Push the appropriate keys to enter numbers, as described below.

Key					[Down]
Number	0	1	2	3	4
	5	6	7	8	9

2. After entering the correct password, the transceiver automatically displays the Standby screen.

NOTE: If the transceiver does not display the Standby screen after entering the password, the entered code may be incorrect. Turn OFF the transceiver, then ON again to reenter the password.

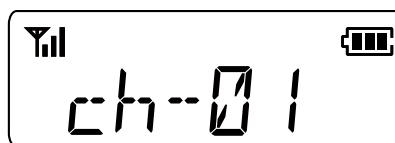
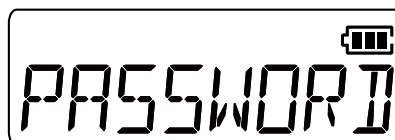

Standby screen (Example)

Selecting a Zone

◇ Selecting a Zone

TIP: What is a “Zone”?

Certain channels are grouped together and assigned to a Zone according to their intended use.

For example, Analog channels ‘Station 1’ and ‘Station 2’ are assigned to an “Analog” Zone, and Digital channels ‘Station 3’ and ‘Station 4’ are assigned to a “Digital” Zone.

To select a Zone:

- Hold down [CH Up/Zone Up] or [CH Down/Zone Down].
 - The selected Zone number or name is briefly displayed, and then returns to the Standby screen.

Selecting a channel

◇ Selecting an operating channel

To select a channel:

- Rotate [Rotary Selector] to select the Favorite CH.
- Push [CH Up], [CH Down], [CH Up/Zone Up], or [CH Down/Zone Down].

◇ Favorite CH function

You can assign Memory Channels as Favorite Channels, for up to 16 channels to the Rotary Selector. The Favorite Channel function enables you to quickly select channels using the Rotary Selector.

1. Set to the desired Rotary Selector position to the channel that you want to update.
2. Move to a current channel that you want to rewrite as a Favorite Channel by pushing [CH Up], [CH/Down], [CH Up/Zone Up], or [CH Down/Zone Down].
3. Hold down [Favorite CH Rewrite] and rewrite the new Favorite Channel to the desired Rotary Selector's position.
 - “FAVORITE” is displayed when the setting is successful.

Call procedure

When your system uses tone signaling, a call procedure may be necessary prior to voice transmission. The tone signaling employed may be a selective calling system, which enables you to call only specific stations, and prevents unwanted stations from contacting you.

CTCSS, DTCS, Common ID must be the same on all of your group transceiver to uses tone signaling.

1. Select a channel according to your system operator's instructions.
① This may not be necessary, depending on the presetting.
2. Push [S-Ring], [S-Ring/C-Ring], [Call] or [Call/C-Ring].
3. After transmitting, the remainder of your communication can be carried out in the normal way.

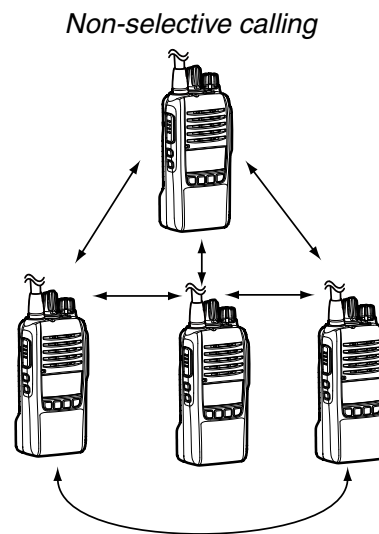
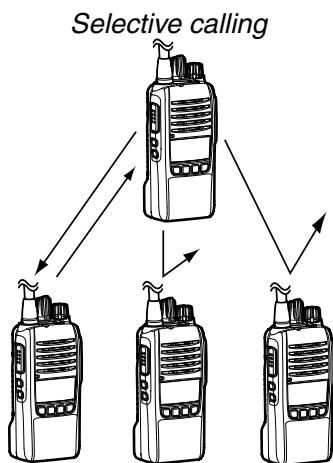

Receiving and transmitting

Receiving:

1. Turn ON the transceiver. (p. 3-2)
2. Select a channel. (p. 3-3)
3. When receiving a call, rotate [VOL] to adjust the audio output level to a comfortable listening level.

Transmitting:

1. Wait for the channel to become clear to avoid interference.
2. While holding down [PTT], speak at your normal voice level.
3. Release [PTT] to receive.

IMPORTANT: To maximize the readability of your signal.

1. Pause briefly after pushing [PTT].
2. Hold the microphone 5 to 10 cm from your mouth, then speak at your normal voice level.

◇ Transmitting notes

Transmit inhibit function

The transceiver has several inhibit functions which restrict transmission under the following conditions:

- The channel is in the Inaudible mode (“”: Audible icon is not displayed.)
- The channel is busy. However, depending on the presetting, you can transmit when a call is received that includes a non-matching (or matching) CTCSS (DTCS), Common ID.
- The selected channel is a ‘receive only’ channel.

Time-Out Timer

If continuous transmission exceeds the preset Time-Out Timer time, transmission is cut off.

Penalty timer

After transmission is cut off by the Time-Out Timer, transmission is further inhibited for a preset penalty period of time.

Section 4 **ADVANCED OPERATION**

Alert-Ring call	4-2
◇ Transmitting an Alert-Ring call	4-2
Sounding a Siren	4-3
AquaQuake™ Water Draining function	4-3
Scan Operation.....	4-3
◇ Scan types	4-3

Alert-Ring call

◇ Transmitting an Alert-Ring call

When the transceiver enters the Alert-Ring mode, a countdown starts. The transceiver counts down during the Repeat Timer set time. Before the Repeat Timer set time expires, the transceiver transmits an Alert-Ring once or repeatedly.

- ① The transceiver automatically transmits a repeat Alert-Ring call until a user turns OFF the transceiver or until holding down [A-Ring] or [Lock/A-Ring].

The transceiver enters the Alert-Ring mode through the following functions:

• The [A-Ring] key function

- ① If holding down [A-Ring] or [Lock/A-Ring], the Alert-Ring mode is canceled.

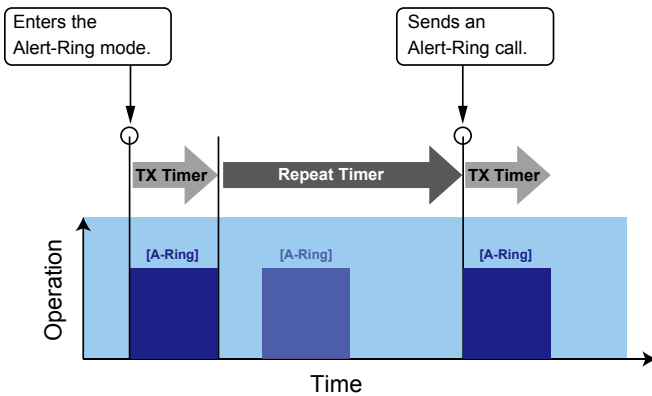

• The Lone Worker function

1. When no operation occurs, the ON Timer presets time.
2. When the transceiver is put into the Alert-Ring mode by the Lone Worker function, the Reminder Timer starts.
 - ① If a user pushes any key before the Reminder Timer set time expires, the Alert-Ring mode is canceled.
3. After the Reminder Timer period ends, the transceiver transmits an Alert-Ring call once or repeatedly.
4. When after period time of TX Timer, automatically starts the count down beep to start the Alert-Ring function.

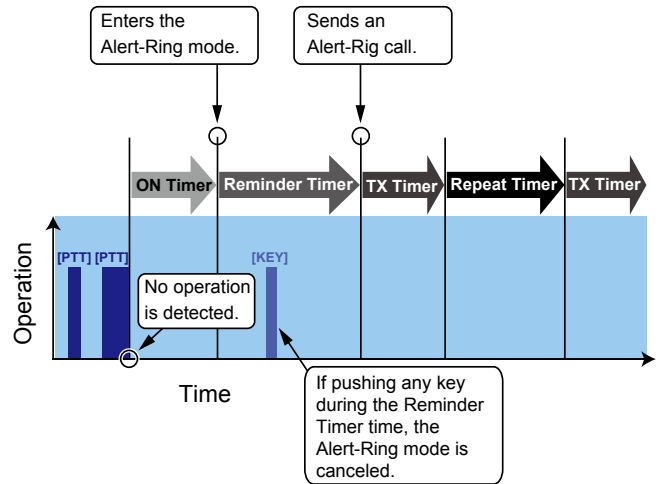

Sounding a Siren

Hold down [Siren] to emit a siren sound from the speaker to let surrounding people know that you are in an Emergency situation.

The siren will sound continuously until the transceiver is turned OFF.

AquaQuake™ Water Draining function

By vibrating the speaker cone, the AquaQuake Water Draining function clears water from the speaker grill to maintain clear audio.

- Hold down [AquaQuake] to turn ON the AquaQuake water draining function.
 - You can also turn ON this function to rotate [VOL] to turn ON the transceiver, while holding down [Up] and [M].
 - A low frequency vibration is generating to remove water from the speaker grill.
 - Water in the speaker grill may muffle the sound coming from the speaker.
- Release the keys to turn OFF the function.

NOTE:

- After the specified period of time expires, this function automatically stops, even if a user continues to hold down these keys.
- These keys works for only the internal speaker.

Scan Operation

◇ Scan types

Scanning is an efficient way to locate signals quickly over all channel.

Selecting Zone Scan mode speeds up the scanning interval.

In addition, repeatedly scanning all zone channels or selected zone channels can be selected.

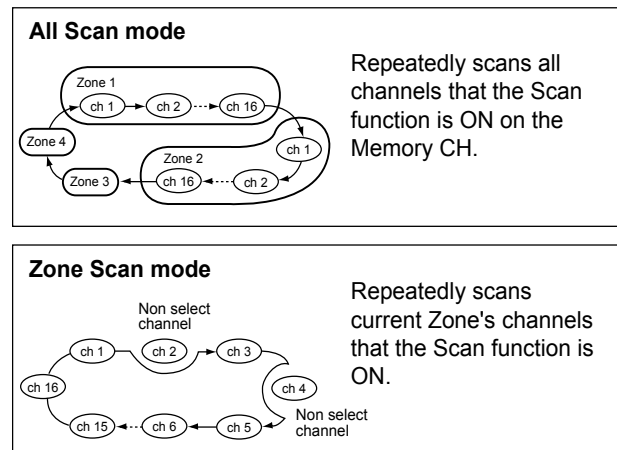

- Hold down [Scan Start/Stop] to select the Scan mode.
- Push [CH Up], [CH Down], [CH Up/Zone Up], or [CH Down/Zone Down] to select the scanning lists.
- Push [Scan Start/Stop] to return to the standby mode.

Section 5 USER SET MODE

User Set mode description	5-2
◇ Operation in the User Set mode	5-2
User Set mode items	5-3
◇ Ringer Type of Digital Ringer and Smart Ringer	5-6

User Set mode description

The user can enter the “User Set Mode” to customize certain transceiver settings without using the programming software.

◇ Operation in the User Set mode

Example: Changing the Ringer level from 3 to 5.

1. Hold down [User Set Mode] for 1 second to enter the User Set mode.
2. Push [User Set Mode] to select an item.
(Example: Selecting Ringer (RINGV))



3. Push [CH Up], [CH Down], [CH Up/Zone Up], or [CH Down/Zone Down] to select an option.
(Example: Selecting Level 5)



• The selected option is automatically set.

4. Hold down [User Set Mode] for 1 second to return to the Standby screen.

User Set mode items

Item	Description	Display	Reference
Backlight	Sets the Key Backlight status.	LIGT	p. 5-4
Beep	Turns the key-touch beeps ON or OFF.	BEEP	p. 5-4
Beep Level	Sets the beep and announce output level.	BEEPV	p. 5-4
Ringer Level	Sets the Ringer output level.	RINGV	p. 5-4
SQL Level (Squelch Level)	Sets the squelch level.	SQL	p. 5-4
AF Min Level (AF Minimum Level)	Sets the minimum audio output level.	AFMIN	p. 5-4
Mic Gain (Microphone Gain)	Sets the microphone sensitivity.	MIC	p. 5-4
VOX	Turns the VOX function ON or OFF.	VOX	p. 5-4
VOX Gain	Sets the VOX gain.	VGAIN	p. 5-4
VOX Delay	Sets the VOX Delay.	VDLY	p. 5-4
Battery Voltage	Displays the battery voltage.	BATT	p. 5-4
Signal Moni (Signal Monitor)	Select whether or not to sound a ringer while making a Call-Ring call or an Alert-Ring call.	SMON	p. 5-4
Call-Ring Pattern	Sets the Call-Ring Pattern.	C.RIG	p. 5-4
Digital Ringer	Sets the ringer type when a Call request is received.	D.RIG	p. 5-4
Smart Ringer	Sets the ringer type when a Smart-Ringer is received.	S.RIG	p. 5-4
Ringer Timer	Sets the Ringer Timer for the Auto CH function.	RTIM	p. 5-4
Code Type	Sets the display format in the CTCSS tone or DTCS code selection mode.	TYPE	p. 5-5
Power Save	Set the Power Save function ON or OFF.	PSAV	p. 5-5
Lone Worker	Turns the Lone Worker function ON or OFF.	LONE	p. 5-5

User Set mode items (Continued)

Backlight

Sets the Backlight status.

- OFF: Turns OFF the backlight.
- OFF Auto: When pushing any key (except [PTT]), the backlight automatically turns ON for 5 seconds.
- OFF Auto2: When pushing any key (except [PTT]), or when changing the displayed contents of the LCD, the backlight automatically turns ON for 5 seconds.
- ON: The backlight is turned ON all the time.

Beep

Turns the key-touch beeps ON or OFF.

Beep Level

Sets the beep and announce output level.

- Range: 1 ~ 5, or 1 (Linked) ~ 5 (Linked).
When setting the Linked option, the beep and announce output levels are adjusted with [VOL].

Ringer Level

Sets the Ringer output level.

- Range: 1 ~ 5, or 1 (Linked) ~ 5 (Linked).
When setting the Linked option, the ringer level is adjusted with [VOL].

SQL Level (Squelch Level)

Sets the squelch level.

- Range: 0 (open) ~ 9 (tight)

AF Min Level (AF Minimum Level)

Sets the minimum audio output level.

This function sets the minimum audio output level and [VOL] cannot adjust the audio lower than the set level.

- Range: 0 ~ 255

Mic Gain (Microphone Gain)

Sets the microphone sensitivity.

- Range: 1 (low sensitivity) ~ 4 (high sensitivity)

VOX

Turns the VOX function ON or OFF.

NOTE: To use the function, a headset and a VOX converter cable are required (purchase separately).

VOX Gain

Sets the VOX gain.

The VOX function automatically switches between receive and transmit by detecting sounds. Higher values make the VOX function more sensitive to sounds.

- Range: 1 ~ 10

VOX Delay

Sets the period of time the transceiver continues transmitting after the user stops speaking, and then the VOX switches to receive.

- Range: 0.5 ~ 3.0 seconds

Battery Voltage

Sets whether or not to display the battery voltage when turning ON the transceiver.

Signal Moni (Signal Monitor)

Select whether or not to sound a ringer while making a Call-Ring call or an Alert-Ring call.

- OFF: The ringer does not sound while making a Call-Ring call or an Alert-Ring call.
- ON: The ringer sounds while making a Call-Ring call or an Alert-Ring call.

Call-Ring Pattern

Selects the Call-Ring Pattern to call by placing a melody on the transmission modulation.

- ① The Call-Ring Pattern function has 16 types of Melody pattern for use with the Call-Ring function.

Digital Ringer

Sets the ringer type for when a Call request is received.

- ① See pages 5-6 ~ 5-8 for details of Ringer Type.

Smart Ringer

Sets the ringer type for when a Smart-Ringer is received.

- ① See pages 5-6 ~ 5-8 for details of Ringer Type.

Ringer Timer

Sets the Ringer Timer for the Auto CH function.

The Ringer timer defines the transmit time that the Auto CH function is ON.

After the set time has passed, the Auto CH function will stop transmitting and restart the scan according to the Auto Reset Timer setting.

- Range: 0 ~ 16 seconds

User Set mode items (Continued)

Code Type

Sets the display format in the CTCSS tone or DTCS code selection mode.

- Code: Displays CTCSS tone or DTCS code.
- Num: Displays CTCSS or DTCS CH No.

Power Save

Sets the Power Save function ON or OFF.

This function reduces the current drain and conserves battery power by deactivating the receiver circuit according to the Power Save start timers.

The Power Save function automatically starts a power save action and reduces the consumption of the battery charge.

- OFF: Turns OFF the function.
- Analog: To activate in the Analog mode.
- Digital: To activate in the Digital mode.
- Both: To activate in the Analog and Digital mode.

Lone Worker

Sets whether or not to automatically enter the Alert-Ring mode when no operation occurs during the set period of time.

User Set mode items (Continued)

◇ Ringer Type of Digital Ringer and Smart Ringer

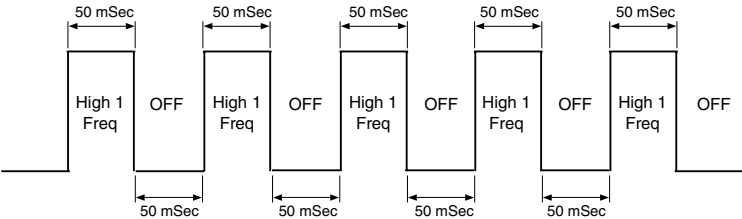
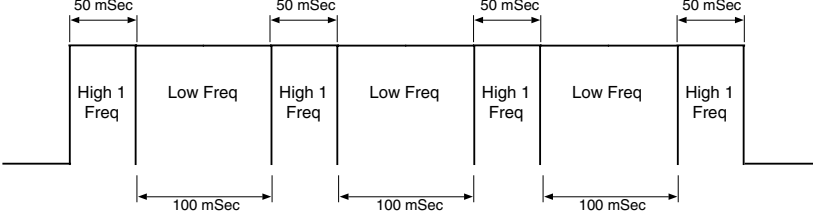
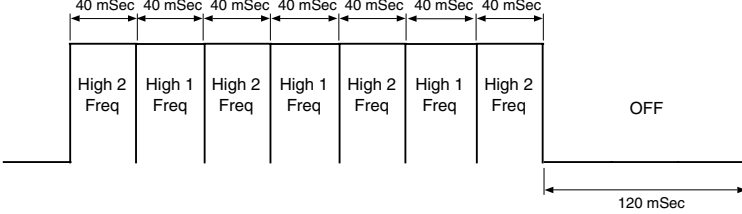
Options	Ringer Type	Description
-	Null	The state of the ringer does not change.
OFF	OFF	Turns OFF the ringer.
1	Pi	One high ring sounds once.
2	PiPi	Two high rings sound once.
3	Pi-	One high long ring sounds once.
4	PiPiPiPiPi	Five high rings sound once. 
5	PiRo1	The following ringer pattern sounds only once. 
6	PiRo2	The following ringer pattern sounds twice. 
1*	Pi (Repeat)	One high ring repeatedly sounds during the ringer repeat timer period.
2*	PiPi (Repeat)	Two high rings repeatedly sound during the ringer repeat timer period.
3*	Pi- (Repeat)	One high long ring sounds during the ringer repeat timer period.
4*	PiPiPiPiPi (Repeat)	Five high rings sound during the ringer repeat timer period.
5*	PiRo1 (Repeat)	One high and one low rings repeatedly sound during the ringer repeat timer period.
6*	PiRo2 (Repeat)	One high and one low rings rapidly and repeatedly sound during the ringer repeat timer period.
7~22	Melody1 to Melody16	The selected ringer pattern between Melody 1 and Melody 16 sounds.
7*~22*	Melody1 (Repeat) to Melody16 (Repeat)	The selected ringer pattern between Melody 1 and Melody 16 sounds during the ringer repeat timer period.

► Continued on the next page

User Set mode items (Continued)

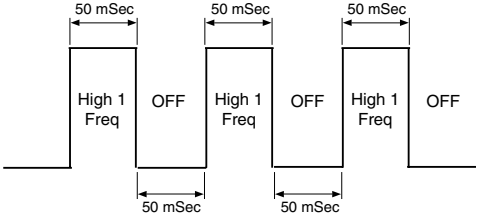
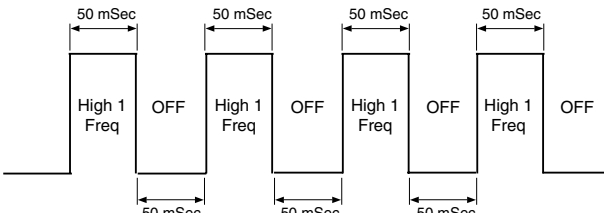
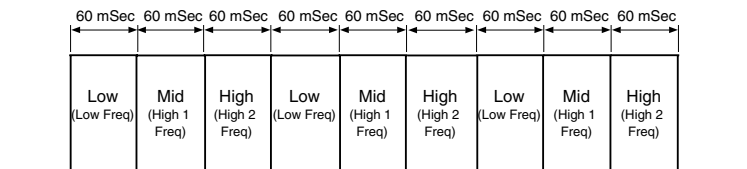
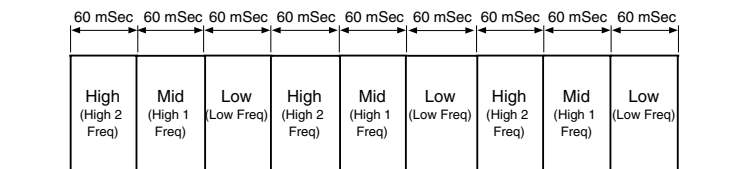
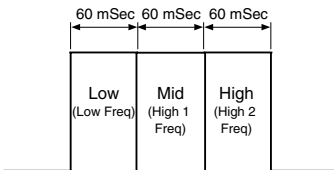
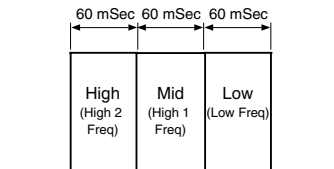
Options	Ringer Type	Description
23	PiPiPi	Three high rings sound once. 
24	PiPiPiPi	Four high rings sound once. 
25	PiBu	One high and one low rings sound once.
26	BuPi	One low and one high rings sound once.
27	BuRoPi x3	One low, one mid and one high rings sound three times. 
28	PiRoBu x3	One high, one mid, and one low rings sound three times. 
29	BuRoPi	One low, one mid and one high rings sound once. 
30	PiRoBu	One high, one mid, and one low rings sound once. 

User Set mode items (Continued)

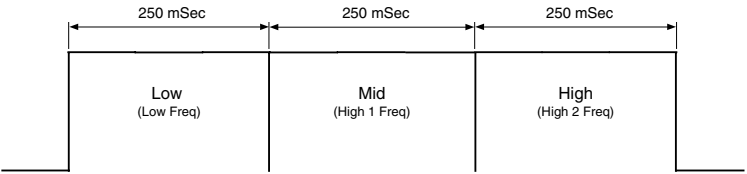
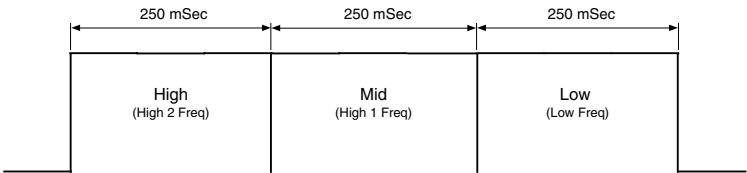
Options	Ringer Type	Description
31	Pi-Pi-Pi-Pi-	Four high long rings sound once.
32	Bu-Ro-Pi-	One low, one mid and one high long rings sound once. 
33	Pi-Ro-Bu-	One high, one mid, and one low long rings sound once. 
23*	PiPiPi (Repeat)	Three high rings sound during the ringer repeat timer period.
24*	PiPiPiPi (Repeat)	Four high rings sound during the ringer repeat timer period.
25*	PiBu (Repeat)	One high and one low rings sound during the ringer repeat timer period.
26*	BuPi (Repeat)	One low and one high rings sound during the ringer repeat timer period.
27*	BuRoPi x3 (Repeat)	One low, one mid and one high rings sound three times during the ringer repeat timer period.
28*	PiRoBu x3 (Repeat)	One high, one mid, and one low rings sound three times during the ringer repeat timer period.
29*	BuRoPi (Repeat)	One low, one mid and one high rings sound during the ringer repeat timer period.
30*	PiRoBu (Repeat)	One high, one mid, and one low rings sound during the ringer repeat timer period.
31*	Pi-Pi-Pi-Pi- (Repeat)	Four high long rings sound during the ringer repeat timer period.
32*	Bu-Ro-Pi- (Repeat)	One low, one mid and one high long rings sound during the ringer repeat timer period.
33*	Pi-Ro-Bu- (Repeat)	One high, one mid, and one low long rings sound during the ringer repeat timer period.

Section 6

dPMR™ OPERATION

Receiving a call	6-2
◇ Receiving a call.....	6-2
◇ Receiving a Status message	6-2
◇ Receiving a Break-in request call	6-3
Transmitting a call	6-4
◇ General	6-4
◇ Transmitting a call.....	6-4
◇ Transmitting a Status message	6-4
◇ Transmitting a Break-in request call	6-4
◇ Transmitting an Alert-Ring call	6-4

Receiving a call

◇ Receiving a call

When a call is received:

- Mute is released.
 - The Status indicator lights green.
1. Hold down [PTT] to speak.
 2. Release [PTT] to receive.

◇ Receiving a Status message

When a Status message is received:

- Beeps sound.
- The Status message is alternately displayed. “” may be displayed or blink, depending on the presetting.
- The Status Indicator may blink orange once or twice, depending on the presetting.

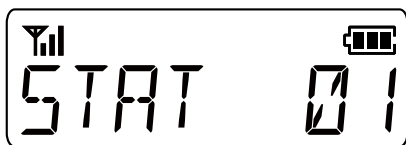

Push [PTT] or any key to stop the display indication.

Receiving a call (Continued)

◇ Receiving a Break-in request call

- When a Break-in call is received:
- The Status indicator lights green.
 - Beeps sound.
 - “BREAK” blinks on the display.

TIP: What is Break-in call?

The Break-in request call announces to the other stations on the channel that the user wants to break into the current communication in the group.

The transceiver waits for the current communication to end, and then sends the call.

Example: Station A, B, and C are communicating using the same Common ID.

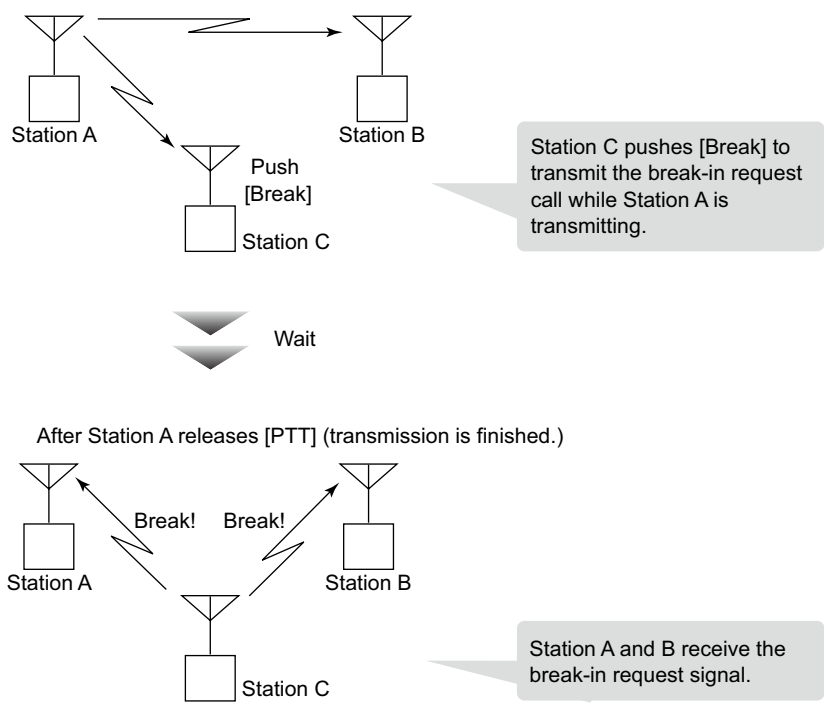

Transmitting a call

You can make a call to a station that has the same Common ID. Other digital mode transceivers on the channel will not receive a call that does not match their Common ID.

Before making a call, wait until the channel is clear to avoid interference.

◇ General

The target ID (Common ID) are preset to a channel. To make a call, you should select the desired channel that your target station is set to.

◇ Transmitting a call

<Using [PTT]>

1. Select a channel as described below.
 - Push [CH Up], [CH Down], [CH Up/Zone Up], or [CH Down/Zone Down].
 - Rotate [Rotary Selector].



2. Push [PTT] to transmit a call.
3. Hold down [PTT] to speak.
4. Release [PTT] to receive.

<Using the C-Ring function>

1. Select a channel as described below.
 - Push [CH Up], [CH Down], [CH Up/Zone Up], or [CH Down/Zone Down].
 - Rotate [Rotary Selector].
2. Holding down [C-Ring], [Call/C-Ring] or [S-Ring/C-Ring] while transmitting.
3. Hold down [PTT] to speak.
4. Release [PTT] to receive.

<Using the Call function>

1. Select a channel as described below.
 - Push [CH Up], [CH Down], [CH Up/Zone Up], or [CH Down/Zone Down].
2. Push [Call] or [Call/C-Ring] to send a call request.
3. Hold down [PTT] to speak.
4. Release [PTT] to receive.

◇ Transmitting a Status message

You can transmit a preset simple message. You cannot transmit a voice signal at the same time.

1. Push [Select] or hold down [Code/ Select] to turn the Status select mode.
2. Push [CH Up], [CH Down], [CH Up/Zone Up], or [CH Down/Zone Down] to select a status.
3. Push [Call] to transmit a Status message.

◇ Transmitting a Break-in request call

1. While receiving a signal, push [Break].
 - “WAIT” is displayed.
 - Pushing [Clear] or [Break] to cancel the call.
2. When the received signal is disappeared, the break-in request call is automatically transmitted.
 - “COMPLETE” is displayed when the break-in request call is successful.
 - ① The transceiver that received a Break signal blinks “BREAK” on the display.
3. Push and hold [PTT], then speak into the microphone at your a normal voice level.

◇ Transmitting an Alert-Ring call

See “Alert-Ring Call” for details. (p.4-2)

Count on us!

