

PUBLICATION NUMBER: 10515-0007-4300
DECEMBER 1995
Rev. A

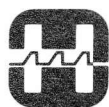

HARRIS

RF COMMUNICATIONS

RT-1694

RECEIVER-TRANSMITTER

**INTERMEDIATE MAINTENANCE
MANUAL**

ADDENDUM

ADDENDUM NO: L952	APPLIES TO (RF Model or Product Name): RT-1694 Receiver-Transmitter	DATE: March 1996
ADDENDUM TO (Publication Number/Revision): (10515-0007-4300 Rev. A)		FOR (Specific Application): All Manuals

The following pages have been removed and replaced in the RT-1694 Receiver-Transmitter manual.

- Page 1-7/1-8 (Figure 1-3)
- Page 1-29/1-30
- Pages 4-1, 4-2, 4-5, 4-6, 4-7, 4-8
- Pages 5-1, 5-2, 5-41/5-42, 5-43/5-44, 5-45/5-46, 5-47/5-48, 5-49/5-50, 5-51/5-52, 5-53/5-54, 5-55/5-56

RT-1694

RECEIVER-TRANSMITTER

INTERMEDIATE MAINTENANCE MANUAL

Copyright © 1995
By Harris Corporation
All Rights Reserved



When an Adult Stops Breathing

WARNING

DO NOT attempt to perform the rescue breathing techniques provided on this page, unless certified. Performance of these techniques by uncertified personnel could result in further injury or death to the victim.

1 Does the Person Respond?

- Tap or gently shake victim.
- Shout, "Are you OK?"

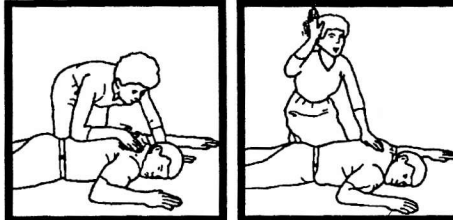

2 Shout, "Help!"

- Call people who can phone for help.

3 Roll Person Onto Back

- Roll victim toward you by pulling slowly.

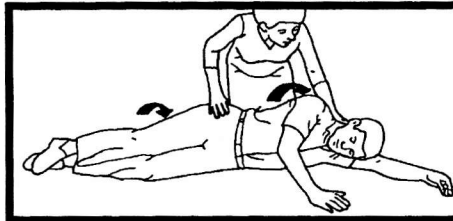

4 Open Airway

- Tilt head back and lift chin.

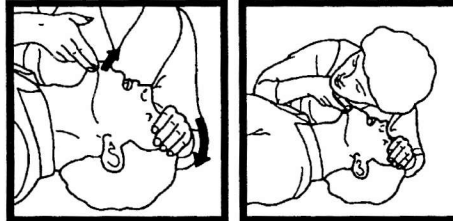

5 Check for Breathing

- Look, listen, and feel for breathing for 3 to 5 seconds.

6 Give 2 Full Breaths

- Keep head tilted back.
- Pinch nose shut.
- Seal your lips tight around victim's mouth.
- Give 2 full breaths for 1 to 1-1/2 seconds each.



7 Check for Pulse at Side of Neck

- Feel for pulse for 5 to 10 seconds.



8 Phone EMS for Help

- Send someone to call an ambulance.

9 Begin Rescue Breathing

- Keep head tilted back.
- Lift chin.
- Pinch nose shut.
- Give 1 full breath every 5 seconds.
- Look, listen, and feel for breathing between breaths.



10 Recheck Pulse Every Minute

- Keep head tilted back.
- Feel for pulse for 5 to 10 seconds.
- If victim has pulse but is not breathing, continue rescue breathing. If no pulse, begin CPR.

List of Abbreviations and Acronyms

Abbreviation	Term
A, AMP	Ampere(s)
ac, AC	Alternating Current
ACE	Advanced Crypto Engine
A/D	Analog-to-Digital Converter
ADC	Analog-to-Digital Converter
ADDR	Address
ADP	Automated Data Processing
ADT	Administrative Delay Time, Automated Data Terminal
ADU	Automatic Dialing Unit
AF	Audio Frequency
AFC	Automatic Frequency Control
AFSK	Audio Frequency Shift Keying
A-G, A/G	Air-to-Ground
AGC	Automatic Gain Control
AIC	Analog Interface Chip
ALC	Automatic Level Control
ALE	Automatic Link Establishment
AMD	Automatic Message Display
AME	Amplitude Modulation Equivalent
ANT	Antenna
ANTIVOX	Voice-Operated Transmitter Key Inhibitor
API	Analog Phase Interpolation
ARQ	Automatic Repeat on Request
ASI	Analog Signal Interface
ASK	Amplitude Shift Keying
ATE	Automatic Test Equipment
AUD	Audio
AUX	Auxiliary
AVS	Analog Voice Security
AWG	American Wire Gauge
B/A	Buffer Amplifier

List of Abbreviations and Acronyms – Continued

Abbreviation	Term
BC	Broadcast, Binary Counter
BCD	Binary-Coded Decimal
BD	Baud, Binary Decoder
BER	Bit Error Rate
BFO	Beat-Frequency Oscillator
BIT	Built-In Test
BITE	Built-In Test Equipment
BPI	Bits Per Inch
bps	Bits Per Second
BPSK	Binary Phase Shift Keying
Btu	British Thermal Unit
BW	Bandwidth
CARC	Chemical Agent Resistive Coating
CB	Circuit Breaker
CCW	Counterclockwise
CDR	Critical Design Review
CDRL	Contract Data Requirements List
CFE	Contractor-Furnished Equipment
CH, CHAN	Channel
CI	Configuration Item
CKT	Circuit
cm	Centimeter
CMOS	Complimentary-Metal-Oxide-Semiconductor
CNTL	Control
CPU	Central Processing Unit
CRC	Cyclic Redundancy Check
CRT	Cathode Ray Tube
CSM	Crypto Synch Message
CTRL	Control
CTS	Clear to Send
CW	Continuous Wave, Clockwise
D/A	Digital-to-Analog Converter

List of Abbreviations and Acronyms – Continued

Abbreviation	Term
DAC	Digital-to-Analog Converter
DAM	Direct Access Memory
dB	Decibel(s)
dBm	Decibels referenced to 1 milliwatt
dc, DC	Direct Current
DCD	Data Carrier Detect
DE	Data Encryption
Demod	Demodulated
Diff	Differential
Dip, DIP	Dual In-Line Package
DMM	Digital Multimeter
DP	Double Pole
DPDT	Double Pole, Double Throw
DPRAM	Dual-Port RAM
DPST	Double Pole, Single Throw
DSP	Digital Signal Processor
DSR	Data Set Ready
DTL	Diode Transistor Logic
DTM	Data Text Message
DV	Digitized Voice
DTMF	Dual Tone Multi-Frequency
DTR	Data Terminal Ready
DUART	Dual Universal Asynchronous Receiver-Transmitter
DUSART	Dual Universal Synchronous/Asynchronous Receiver-Transmitter
DVM	Digital Voltmeter
DVOM	Digital Volt-Ohm Meter
EAM	Embedded Adaptive Module
EAROM	Electronically Alterable Read Only Memory
ECM	Electronic Counter Measure
ECCM	Electronic Counter-Counter Measure
EEPROM, E ² PROM	Electrically Erasable Programmable Read Only Memory

List of Abbreviations and Acronyms – Continued

Abbreviation	Term
EMI	Electromagnetic Interference
EOM	End of Message
EPROM	Erasable Programmable Read-Only Memory
FCC	Federal Communications Commission
FD	Full Duplex
FEC	Forward Error Correction
FET	Field-Effect Transistor
F/F	Flip-Flop
FFT	Fast Fourier Transform
FH	Frequency Hopping
FSK	Frequency Shift Keying
F/W, FW	Firmware
G-A, G/A	Ground-to-Air
GF	Government (or customer) Furnished
GFE	Government-Furnished Equipment
Gnd, GND	Ground
GPIB	General Purpose Interface Bus
HD	Half Duplex
HDCP	Harris Data Communications Protocol
HF	High Frequency
HSS	High-Speed Synchronizer
HSSB	High-Speed Serial Bus
HWCI	Hardware Configuration Item
Hz	Hertz
IC	Integrated Circuit
ID	Identification
IDF	Intermediate Distribution Frame
IF	Intermediate Frequency
INT	Interrupt
INTLK	Interlock
INTR	Interrupt

List of Abbreviations and Acronyms – Continued

Abbreviation	Term
I/O	Input/Output
ISB	Independent Sideband
J	Joules
k	Kilo (thousand)
kbyte	Kilobyte
kHz	Kilohertz
km	Kilometer(s)
kV	Kilovolt(s)
kVA	Kilovolt Ampere(s)
KVD	Keyboard Visual Display
KVDU	Keyboard Visual Display Unit
kW	Kilowatt(s)
LBT	Listen Before Transmit
LC	Inductive Capacitive
LCD	Liquid Crystal Display
LD	Lock Detect
LED	Light-Emitting Diode
LF	Low Frequency
LLSB	Lower Lower Sideband
LOS	Line of Sight
LP	Low Pass
LPC	Linear Predictive Coding
LQA	Link Quality Analysis
LRU	Line Replaceable Unit
LSB	Lower Sideband
LSD	Least Significant Digit
M	Meter, Mega (one million)
m	Milli, one-one thousandth
mA	Milliampere(s)
Mbyte	Megabyte
MDM	MODEM

List of Abbreviations and Acronyms – Continued

Abbreviation	Term
MHz	Megahertz
MIC	Microphone
MIL-STD	Military Standard
mm	Millimeter(s)
Mod	Modification, Modulated
Mod/Demod	Modulator/Demodulator
Modem	Modulator/Demodulator
MOS	Metal Oxide Semiconductor
MOSFET	Metal Oxide Semiconductor Field Effect Transistor
ms, msec	Millisecond
MTBCF	Mean Time Between Critical Failure
MTBF	Mean Time Between Failure
MTBM	Mean Time Between Maintenance
MTBR	Mean Time Between Replacement
MUF	Maximum Usable Frequency
Mux	Multiplex, Multiplexer
mVac	Millivolts Alternating Current
mVdc	Millivolts Direct Current
n	Nano (1 x 10 ⁻⁹)
NB	Narrowband
NC, N.C.	Normally Closed
N/C	Not Connected
NMOS	N-channel Metal-Oxide-Semiconductor
NO, N.O.	Normally Open
No.	Number
NPN	N-type, P-type, N-type (transistor)
nsec	Nanoseconds
NVG	Night Vision Goggles
Ω	Ohms, a unit of resistance measurement
O&M	Operation and Maintenance

List of Abbreviations and Acronyms – Continued

Abbreviation	Term
O&R	Operation and Repair
O.C.	Open Circuit or Open Collector
OEM	Original Equipment Manufacturer
Op Amp	Operational Amplifier
OCXO	Oven Controlled Crystal Oscillator
p	Pico
PA	Power Amplifier
PABX	Private Automatic Branch Exchange
PCB	Printed Circuit Board
PCM	Pulse Code Modulation
PEP	Peak Envelope Power
pF	Picofarad (1 x 10 ⁻¹² Farads)
PIV	Peak Inverse Voltage
PLL	Phase-Locked Loop
PNP	P-type, N-type, P-type (transistor)
P-P	Peak-to-Peak
PROM	Programmable Read Only Memory
PS	Power Supply
Pt Pt, Pt-Pt	Point-to-Point
PTT	Push-to-Talk
PWB	Printed Wiring Board
QTY	Quantity
R, RG	Receiver Circuit: Receive, Receive Ground (from teletype)
RAD	Random Access Data
RAM	Random Access Memory
RC	Resistive Capacitive
RCU	Remote Control Unit
RCV/RX	Receive
RCVR	Receiver
RD	Read
RDY	Ready

List of Abbreviations and Acronyms – Continued

Abbreviation	Term
REC	Receptacle
RETX	Retransmit
RF	Radio Frequency
RFI	Radio-Frequency Interference
RLPA	Rotatable Log Periodic Antenna
RLSD	Receive Level Sense Detect
RMS	Root Mean Squared
ROM	Read-Only Memory
RST	Reset
RTC	Real Time Clock
RTN	Return
RTS	Request to Send
RTTY	Radio Teletype
RTU	Remote Terminal Unit
S, SG	Send Circuit, Send Ground (to teletype)
SA	Spectrum Analyzer
SB	Sideband
SCR	Silicon Controlled Rectifier
SHLD	Shield
SINAD	A ratio of (signal + noise + distortion) to (noise + distortion) used to measure the signal quality of a communication channel. SINAD is commonly used to evaluate the ability of a channel to pass voice traffic.
Sip, SIP	Single In-Line Package
SMD	Surface-Mount Device
SNR	Signal-to-Noise Ratio
SOM	Start of Message
SP	Single Pole
SPDT	Single-Pole, Double-Throw
SSB	Single Sideband
ST	Single Throw
SWR	Standing Wave Ratio
SYNC	Synchronous

List of Abbreviations and Acronyms – Continued

Abbreviation	Term
TB	Terminal Board
TCXO	Temperature Controlled Crystal Oscillator
TDQPSK	Time Differential Quaternary Phase Shift Keying
TGC	Transmitter Gain Control
T/R	Transmit/Receive
TT	Teletype
TTL	Transistor-Transistor Logic
TT VFT	Teletype Voice Frequency Tone
TTY	Teletype
TX	Transmit
u	Micro (1×10^{-6})
UART	Universal Asynchronous Receiver-Transmitter
uF	Microfarad (1×10^{-6} Farads)
UHF	Ultra High Frequency
USART	Universal Synchronous/Asynchronous Receiver-Transmitter
USB	Upper Sideband
usec	Microseconds
UUSB	Upper Upper Sideband
UUT	Unit Under Test
uW	Microwave
V	Volt
VA	Volt-Ampere
Vac	Volts, Alternating Current
VCA	Voltage Controlled Attenuator
VCO	Voltage Controlled Oscillator
VDC, Vdc	Volts, Direct Current
VDU	Video Display Unit
VECT	Vector
VF	Voice Frequency
VFO	Variable Frequency Oscillator
VFR	Voice Frequency Repeater

List of Abbreviations and Acronyms – Continued

Abbreviation	Term
VHF	Very High Frequency
VLF	Very Low Frequency
VMOS	V-groove Metal-Oxide-Semiconductor
VOM	Volt-Ohm-Meter
VOX	Voice Operated Transmitter
V _{pp}	Volts peak-to-peak
VSWR	Voltage Standing Wave Ratio
W	Watt(s)
WRL	Wire Run List
XCVR	Transceiver
XMT	Transmit
XMTR	Transmitter

TABLE OF CONTENTS

Paragraph		Page
CHAPTER 1 – GENERAL INFORMATION		
1.1	SAFETY PRECAUTIONS	1-1
1.2	MAINTENANCE LEVELS	1-3
1.2.1	Introduction	1-3
1.2.1.1	Level I	1-3
1.2.1.2	Level II	1-3
1.2.1.3	Level III	1-3
1.2.1.4	Level IV	1-3
1.2.2	Purpose of this Manual	1-3
1.2.3	Maintenance Support Packages	1-3
1.2.4	Scope	1-5
1.2.5	Warranty	1-5
1.3	GENERAL EQUIPMENT DESCRIPTION	1-5
1.3.1	General	1-5
1.3.2	Front Panel	1-5
1.3.3	Rear Panel	1-5
1.3.4	Features	1-5
1.3.5	Configuration Information	1-6
1.3.5.1	Ancillary Kit	1-6
1.3.5.2	Unit Identification	1-6
1.3.6	General System Relationship	1-6
1.3.7	Specifications	1-13
1.4	GENERAL DESCRIPTION OF MAJOR ASSEMBLIES	1-23
1.4.1	General	1-23
1.5	PARTS LISTS OF ITEMS SHIPPED WITH UNIT	1-27
1.6	LIST OF ITEMS REQUIRED BUT NOT SUPPLIED	1-28
CHAPTER 2 – OPERATION		
2.1	INTRODUCTION	2-1
2.1.1	General	2-1
2.2	OPERATOR CONTROLS AND INDICATORS	2-1
2.2.1	General	2-1
2.3	CONNECTORS	2-2
2.4	OPERATING PROCEDURES	2-2
2.4.1	Initial Settings and Power Up	2-2
2.4.1.1	BIT	2-2
2.4.1.1.1	Starting BIT	2-4
2.4.1.1.2	Run-Time Faults	2-5
2.4.2	Normal and Emergency Shutdown	2-6
CHAPTER 3 – FUNCTIONAL DESCRIPTION		
3.1	INTRODUCTION	3-1
3.1.1	General	3-1
3.2	OVERALL FUNCTIONAL DESCRIPTION	3-1
3.2.1	General	3-1
3.2.2	Purpose of the Receiver-Transmitter	3-1

TABLE OF CONTENTS – Continued

Paragraph		Page
CHAPTER 3 – FUNCTIONAL DESCRIPTION – Continued		
3.2.3	Functional Level Descriptions	3-1
3.2.3.1	Analog Clear Voice Functional Level Descriptions	3-1
3.2.3.1.1	Transmitting Analog Clear Voice	3-5
3.2.3.1.2	Receiving Analog Clear Voice	3-5
3.2.3.2	Unencrypted Digital Voice Functional Level Descriptions	3-5
3.2.3.2.1	Transmitting Unencrypted Digital Voice	3-5
3.2.3.2.2	Receiving Unencrypted Digital Voice	3-6
3.2.3.3	Analog Voice Security (AVS) Functional Level Descriptions	3-6
3.2.3.3.1	Transmitting with AVS Enabled	3-6
3.2.3.3.2	Receiving with AVS Enabled	3-11
3.2.3.4	Encrypted Digital Data Functional Level Descriptions	3-11
3.2.3.4.1	Transmitting Encrypted Digital Data	3-11
3.2.3.4.2	Receiving Encrypted Digital Data	3-11
3.2.3.5	Encrypted Digital Voice Functional Level Descriptions	3-12
3.2.3.5.1	Transmitting Encrypted Digital Voice	3-12
3.2.3.5.2	Receiving Encrypted Digital Voice	3-12
3.2.3.6	Automatic Link Establishment (ALE) Functional Level Descriptions	3-13
3.2.3.6.1	Establishing an ALE Link (Transmit Side)	3-13
3.2.3.6.2	Establishing an ALE Link (Receive Side)	3-13
3.2.3.7	Frequency Hopping Functional Level Descriptions	3-21
3.2.3.7.1	Transmitting with Frequency Hopping Enabled	3-21
3.2.3.7.2	Receiving with Frequency Hopping Enabled	3-21
3.2.3.8	Frequency Modulation (FM) Functional Level Descriptions	3-25
3.2.3.8.1	Transmitting FM Signals	3-25
3.2.3.8.2	Receiving FM Signals	3-25
3.3	MAJOR FUNCTION LEVEL DESCRIPTION	3-29
3.3.1	General	3-29
3.3.2	RF/IF/Audio/Digital Signal Path (Analog Clear Voice)	3-29
3.3.2.1	Transmit RF/IF/Audio/Digital Signal Path	3-29
3.3.2.1.1	A10 Front Panel Assembly	3-29
3.3.2.1.2	A4 Signal Processor PWB Assembly	3-29
3.3.2.1.3	A5 Receiver/Exciter Assembly	3-30
3.3.2.1.4	A8 PA/Battery Charger Assembly	3-30
3.3.2.1.5	A9 Antenna Coupler Assembly	3-30
3.3.2.2	Receive RF/IF/Audio/Digital Signal Path	3-30
3.3.2.2.1	A9 Antenna Coupler Assembly	3-30
3.3.2.2.2	A8 Power Amplifier/Battery Charger Assembly	3-31
3.3.2.2.3	A5 Receiver/Exciter Assembly	3-31
3.3.2.2.4	A4 Signal Processor PWB Assembly	3-31
3.3.2.2.5	A10 Front Panel Assembly	3-31
3.3.3	Control Paths (Analog Clear Voice)	3-31
3.3.3.1	A10 Front Panel Assembly	3-31
3.3.3.2	A1A1 Interface PWB Assembly	3-31
3.3.3.3	A1A2 Encryption PWB Assembly	3-32
3.3.3.4	A4 Signal Processor PWB Assembly	3-32
3.3.3.5	A5 Receiver/Exciter Assembly	3-32

TABLE OF CONTENTS – Continued

Paragraph		Page
CHAPTER 3 – FUNCTIONAL DESCRIPTION – Continued		
3.3.3.6	A6 Synthesizer Assembly	3-32
3.3.4	Digital Voice Signal Paths	3-32
3.3.4.1	RF/IF/Audio/Digital Signal Paths (Digital Voice)	3-32
3.3.4.2	Control Signal Paths (Digital Voice)	3-32
3.3.5	AVS Signal Paths	3-33
3.3.5.1	RF/IF/Audio/Digital Signal Paths (AVS)	3-33
3.3.6	Encrypted Digital Data Signal Paths	3-33
3.3.6.1	RF/IF/Audio/Digital Signal Paths (Encrypted Digital Data)	3-33
3.3.7	Encrypted Digital Voice Signal Paths	3-33
3.3.7.1	RF/IF/Audio/Digital Signal Paths (Encrypted Digital Voice)	3-33
3.3.8	ALE Signal Paths	3-34
3.3.8.1	RF/IF/Audio/Digital Signal Paths (ALE) During Link Establishment	3-34
3.3.9	Frequency Hopping Signal Paths	3-35
3.3.9.1	RF/IF/Audio/Digital Signal Paths (Frequency Hopping)	3-35
3.3.9.2	Control Signal Paths (Frequency Hopping)	3-35
3.3.10	FM Signal Paths	3-35
3.3.10.1	RF/IF/Audio/Digital Signal Paths (FM)	3-35
3.3.11	Power Distribution Paths	3-36
3.3.11.1	AC Line Voltage Path	3-36
3.3.11.2	+26 Vdc Path	3-36
3.3.11.3	Power Supply Assembly A7	3-36
3.3.11.4	Voltages and Assemblies	3-36
3.3.11.4.1	Regulated +5 Vdc Line	3-36
3.3.11.4.2	Regulated +6.8 Vdc Line	3-37
3.3.11.4.3	Unregulated +16.5 Vdc Line	3-37
3.3.11.4.4	Regulated -12 Vdc Line	3-37
CHAPTER 4 – SCHEDULED MAINTENANCE		
4.1	INTRODUCTION	4-1
4.1.1	Scheduled Maintenance Procedure List	4-1
4.2	SCHEDULED MAINTENANCE PROCEDURES	4-1
4.2.1	Receive Sensitivity Test	4-1
4.2.1.1	Required Equipment	4-2
4.2.1.2	Test Procedure	4-2
4.2.2	Power Output Measurement	4-5
4.2.2.1	Required Equipment	4-5
4.2.2.2	Test Procedure	4-5
4.2.3	Frequency Accuracy Measurement	4-7
4.2.3.1	Required Equipment	4-7
4.2.3.2	Test Procedure	4-7
4.2.4	Lithium Battery Check	4-9
4.2.4.1	Required Equipment	4-9
4.2.4.2	Test Procedure	4-9

TABLE OF CONTENTS – Continued

Paragraph		Page
CHAPTER 5 – TROUBLESHOOTING		
5.1	INTRODUCTION	5-1
5.1.1	General	5-1
5.1.2	Scope of this Chapter	5-1
5.2	TROUBLESHOOTING PROCEDURES	5-2
5.2.1	General	5-2
5.2.2	Maintenance Turn-On Procedure	5-3
5.2.3	Troubleshooting with Non-Bit Fault Isolation	5-4
5.2.4	Troubleshooting with BIT Fault Isolation	5-5
5.3	TROUBLESHOOTING SUPPORT DATA	5-37
5.3.1	Protective Device Index	5-37
5.3.2	Relay and Lamp Indexes	5-37
5.3.3	Troubleshooting Index	5-37
5.4	TROUBLESHOOTING DIAGRAMS	5-38
5.4.1	General	5-38
5.4.2	BIT Signal Path Diagram	5-38
5.4.3	RF/IF/Audio/Digital/Control Signal Path Diagram	5-38
5.4.4	Power Distribution Diagram	5-38
5.5	INTERCONNECT SCHEMATIC DIAGRAM	5-38
5.5.1	General	5-38
5.6	BIT DESCRIPTION	5-57
5.6.1	General	5-57
5.6.2	BIT Routine	5-57
5.6.3	BIT Test Description	5-57
5.6.3.1	A1A1 Interface PWB Assembly BIT Sequence Description	5-57
5.6.3.1.1	Fault 01 – Communications Fault Test	5-57
5.6.3.1.2	Fault 02 – Microprocessor Internal RAM Fault Test	5-57
5.6.3.1.3	Fault 03 – ROM Fault Test	5-57
5.6.3.1.4	Fault 04 – RAM Fault Test	5-57
5.6.3.1.5	Fault 05 – Asynchronous Data Channel Fault Test	5-57
5.6.3.1.6	Fault 06 – Synchronous Data Channel Fault Test	5-58
5.6.3.1.7	Fault 09 – Remote Communications Channel Fault Test	5-58
5.6.3.1.8	Fault 0A – External PA DUART Counter Fault Test	5-58
5.6.3.1.9	Fault 0B – External PA Communications Channel Fault Test	5-58
5.6.3.1.10	Faults 0F – Frame Clock Fault Test	5-58
5.6.3.1.11	Fault 10 – Semaphore Register Fault Test	5-58
5.6.3.1.12	Fault 11 – Dual Port RAM Fault Test	5-58
5.6.3.1.13	Fault 51 – RTC Fault Test	5-58
5.6.3.1.14	Fault 52 – RTC Internal RAM Fault Test	5-58
5.6.3.1.15	Fault 55 – RTC Rollover Registers Fault Test	5-58
5.6.3.1.16	Fault 56 – RTC Crystal Oscillator Fault Test	5-58
5.6.3.1.17	Fault 81 – Encryption No Communication Fault Test	5-58
5.6.3.2	A1A2 Encryption PWB Assembly BIT Sequence Description	5-59
5.6.3.2.1	Fault 81 – Communications Fault Test	5-59
5.6.3.2.2	Fault 82 – ROM Fault Test	5-59
5.6.3.2.3	Fault 83 – Internal RAM Fault Test	5-59
5.6.3.2.4	Fault 84 – External RAM Fault Test	5-59

TABLE OF CONTENTS – Continued

Paragraph		Page
CHAPTER 5 – TROUBLESHOOTING – Continued		
5.6.3.2.5	Fault 85 – Dual-Port RAM Fault (Encryption Side) Test	5-59
5.6.3.2.6	Fault 86 – Semaphore Register Fault (Encryption Side) Test	5-59
5.6.3.2.7	Fault 87 – ACE Fault Test	5-59
5.6.3.2.8	Fault 88 – HSS Register Fault Test	5-59
5.6.3.2.9	Fault 89 – Encryption Loop Back Fault Test	5-59
5.6.3.3	A3 LPC Vocoder Assembly BIT Sequence Description	5-59
5.6.3.3.1	Fault 01 – 8751 Communications Fault Test	5-59
5.6.3.3.2	Fault 02 – 8751 ROM Fault Test	5-59
5.6.3.3.3	Fault 03 – 8751 Microprocessor Internal RAM Fault Test	5-59
5.6.3.3.4	Fault 05 – 8751 Dual-Port RAM Fault Test	5-60
5.6.3.3.5	Fault 06 – 8751 Dual-Port RAM Busy Fault Test	5-60
5.6.3.3.6	Fault 07 – 8751 Dual-Port RAM Interrupt Fault Test	5-60
5.6.3.3.7	Fault 14 – Hop Clock Fault Test	5-60
5.6.3.3.8	Fault 15 – Frame Clock Fault Test	5-60
5.6.3.3.9	Fault 81 – TMS320 Internal RAM Fault Test	5-60
5.6.3.3.10	Fault 82 – TMS320 External Program RAM Fault Test	5-60
5.6.3.3.11	Fault 83 – TMS320 External Data RAM Fault Test	5-60
5.6.3.3.12	Fault 84 – TMS320 ROM Fault Test	5-60
5.6.3.3.13	Fault 85 – TMS320 Dual-Port RAM Fault Test	5-60
5.6.3.3.14	Fault 86 – Sample Clock Fault Test	5-60
5.6.3.3.15	Fault 87 – TMS320 AIC Fault Test	5-60
5.6.3.3.16	Fault 88 – TMS320 DAC Fault Test	5-60
5.6.3.3.17	Fault F5 – 8751 Not Finished Fault Test	5-61
5.6.3.3.18	Fault FA – TMS320 Not Finished Fault Test	5-61
5.6.3.4	A4 Signal Processor PWB Assembly BIT Sequence Description	5-61
5.6.3.4.1	Fault 01 – Communications Fault Test	5-61
5.6.3.4.2	Fault 14 – Hop Clock Error Test	5-61
5.6.3.4.3	Fault 15 – Frame Clock Fault Test	5-61
5.6.3.4.4	Fault 1F – FEC ROM Checksum Fault Test	5-61
5.6.3.4.5	Fault 20 – FEC External RAM Fault Test	5-61
5.6.3.4.6	Fault 21 – FEC Dual-Port RAM Fault Test	5-61
5.6.3.4.7	Fault 22 – 80C186 (U75) MDM Not Running Test	5-61
5.6.3.4.8	Fault 23 – FFT Handshake Fault Test	5-61
5.6.3.4.9	Fault 24 – FFT to MDM Dual-Port RAM Fault Test	5-61
5.6.3.4.10	Fault 25 – MDM to FFT Dual-Port RAM Fault Test	5-62
5.6.3.4.11	Fault 26 – MDM to FEC Dual-Port RAM Fault Test	5-62
5.6.3.4.12	Fault 27 – MDM ROM Checksum Fault Test	5-62
5.6.3.4.13	Fault 28 – MDM RAM Fault Test	5-62
5.6.3.4.14	Fault 29 – Sample Clock Fault Test	5-62
5.6.3.4.15	Fault 2A – FFT ROM Checksum Test	5-62
5.6.3.4.16	Fault 2B – FFT Internal RAM Fault Test	5-62
5.6.3.4.17	Fault 2C – FFT External RAM Fault Test	5-62
5.6.3.4.18	Fault 2D – FFT to DIF Dual-Port RAM Fault Test	5-62
5.6.3.4.19	Fault 2E – Hop Clock Error Test	5-62
5.6.3.4.20	Fault 2F – FFT Self Test (Not Complete) Test	5-62
5.6.3.4.21	Fault 30 – FFT Self Test (Not Complete) Test	5-62

TABLE OF CONTENTS – Continued

Paragraph		Page
CHAPTER 5 – TROUBLESHOOTING – Continued		
5.6.3.4.22	Fault 32 – Digital IF Time Sample Transfer Test	5-62
5.6.3.4.23	Fault 33 – MDM Self Test (Not Complete) Test	5-63
5.6.3.4.24	Fault 34 – FEC Self Test (Not Complete) Test	5-63
5.6.3.4.25	Fault 42 – Non-Destructive Internal RAM Fault Test	5-63
5.6.3.4.26	Fault 43 – ROM Checksum Fault Test	5-63
5.6.3.4.27	Fault 44 – Non-destructive External RAM Fault Test	5-63
5.6.3.4.28	Fault 61 – AGC Communication Fault Test	5-63
5.6.3.4.29	Fault 62 – AGC Processor Internal RAM Test	5-63
5.6.3.4.30	Fault 63 – AGC Checksum Fault Test	5-63
5.6.3.4.31	Fault 64 – AGC External RAM Fault Test	5-63
5.6.3.4.32	Fault 67 – Digital IF Handshake Fault (Dual Port RAM) Test	5-63
5.6.3.4.33	Fault 6B – Digital IF Did Not Complete BITE Test	5-63
5.6.3.4.34	Fault 6C – Anti-alias Filter Test	5-64
5.6.3.4.35	Fault 6D – 28.8-kHz Sample Clock Fault and Fault 6E – 24.0-kHz Sample Clock Fault Test	5-64
5.6.3.4.36	Fault 74 – Frame Clock Not Detected Test	5-64
5.6.3.4.37	Fault 75 – Hop Clock Not Detected Test	5-64
5.6.3.4.38	Fault 80 – Digital IF ROM Checksum Fault Test	5-64
5.6.3.4.39	Fault 81 – Digital IF Internal RAM Fault Test	5-64
5.6.3.4.40	Fault 82 – Digital IF External RAM Fault Test	5-64
5.6.3.4.41	Fault 83 – Dual-Port RAM to AGC Fault Test	5-64
5.6.3.4.42	Fault 84 – Dual-Port RAM to FFT Fault Test	5-64
5.6.3.5	A5 Receiver/Exciter Assembly BIT Sequence Description	5-64
5.6.3.5.1	Receiver Faults 01 through 04	5-64
5.6.3.5.2	Exciter Faults 0F through 12	5-64
5.6.3.6	A6 Synthesizer Assembly BIT Sequence Description	5-65
5.6.3.6.1	Fault 12 – Combined Lock Detect Fault Test	5-65
5.6.3.6.2	Fault 20 – Serial EEPROM Data Read Fault Test	5-65
5.6.3.7	A8 Power Amplifier/Battery Charger Assembly BIT Sequence Description ..	5-65
5.6.3.8	A9 Antenna Coupler Assembly BIT Sequence Description	5-65
5.6.3.8.1	Fault 01 – Coupler Operational Fault Test	5-65
5.6.3.9	A10 Front Panel Assembly BIT Sequence Description	5-65
5.6.3.9.1	Fault 02 – Microprocessor Internal RAM Fault Test	5-65
5.6.3.9.2	Fault 03 – ROM Fault Test	5-65
5.6.3.9.3	Fault 04 – External RAM Fault Test	5-65
5.6.3.9.4	Fault 05 – LCD Fault Test	5-65
5.6.3.10	Self-Diagnostics Sequence Summary	5-66
CHAPTER 6 – CORRECTIVE MAINTENANCE		
6.1	INTRODUCTION	6-1
6.1.1	Master Tools and Materials List	6-1
6.2	ADJUSTMENTS AND ALIGNMENTS	6-2
6.2.1	General	6-2
6.3	REMOVAL AND REPLACEMENT PROCEDURES	6-2
6.3.1	Safety	6-2

TABLE OF CONTENTS – Continued

Paragraph		Page
CHAPTER 6 – CORRECTIVE MAINTENANCE		
6.3.2	Level III Repair	6-3
6.3.3	Attaching Hardware	6-3
6.3.4	Repair Tips	6-3
6.3.5	Tools	6-3
6.3.6	Wires, Cables, and Connectors	6-4
6.4	UNIT REMOVAL AND REPLACEMENT PROCEDURES	6-5
6.4.1	General	6-5
6.4.2	Removing and Applying AC Input Power	6-5
6.4.2.1	Removing AC Input Power	6-5
6.4.2.2	Applying AC Input Power	6-5
6.4.3	Receiver-Transmitter Removal and Replacement	6-5
6.5	SHOP REPLACEABLE UNIT (SRU) REMOVAL AND REPLACEMENT PROCEDURES	6-5
6.5.1	MP2 Radio Case and Gasket Assembly Removal and Replacement	6-9
6.5.1.1	MP2 Radio Case and Gasket Assembly Removal	6-9
6.5.1.2	MP2 Radio Case and Gasket Assembly Replacement	6-9
6.5.2	MP3 PWB Compartment Cover Assembly Removal and Replacement	6-11
6.5.2.1	MP3 PWB Compartment Cover Assembly Removal	6-11
6.5.2.2	MP3 PWB Compartment Cover Assembly Replacement	6-11
6.5.3	A1A1 Interface and A1A2 Encryption PWB Assembly Removal and Replacement	6-13
6.5.3.1	A1A1 Interface and A1A2 Encryption PWB Assembly Removal	6-13
6.5.3.2	A1A1 Interface and A1A2 Encryption PWB Assembly Replacement	6-14
6.5.4	A3 LPC Vocoder Assembly Removal and Replacement	6-16
6.5.4.1	A3 LPC Vocoder Assembly Removal	6-16
6.5.4.2	A3 LPC Vocoder Assembly Replacement	6-16
6.5.5	A4 Signal Processor PWB Assembly Removal and Replacement	6-18
6.5.5.1	A4 Signal Processor PWB Assembly Removal	6-18
6.5.5.2	A4 Signal Processor PWB Assembly Replacement	6-18
6.5.6	A5 Receiver/Exciter Assembly Removal and Replacement	6-20
6.5.6.1	A5 Receiver/Exciter Assembly Removal	6-20
6.5.6.2	A5 Receiver/Exciter Assembly Replacement	6-20
6.5.7	A6 Synthesizer Assembly Removal and Replacement	6-22
6.5.7.1	A6 Synthesizer Assembly Removal	6-22
6.5.7.2	A6 Synthesizer Assembly Replacement	6-22
6.5.8	A7 Power Supply Assembly Removal and Replacement	6-24
6.5.8.1	A7 Power Supply Assembly Removal	6-24
6.5.8.2	A7 Power Supply Assembly Replacement	6-24
6.5.9	A8 PA/Battery Charger Assembly Removal and Replacement	6-26
6.5.9.1	A8 PA/Battery Charger Assembly Removal	6-26
6.5.9.2	A8 PA/Battery Charger Assembly Replacement	6-27
6.5.10	A9 Antenna Coupler Assembly Removal and Replacement	6-31
6.5.10.1	A9 Antenna Coupler Assembly Removal	6-31
6.5.10.2	A9 Antenna Coupler Assembly Replacement	6-32
6.5.11	A10 Front Panel Assembly Removal and Replacement	6-35
6.5.11.1	A10 Front Panel Assembly Removal	6-35

TABLE OF CONTENTS – Continued

Paragraph		Page
CHAPTER 6 – CORRECTIVE MAINTENANCE		
6.5.11.2	A10 Front Panel Assembly Replacement	6-36
6.5.12	A11 Motherboard Assembly Removal and Replacement	6-38
6.5.12.1	A11 Motherboard Assembly Removal	6-38
6.5.12.2	A11 Motherboard Assembly Replacement	6-39
6.5.13	W1 Coaxial Cable Assembly Removal and Replacement	6-41
6.5.13.1	W1 Coaxial Cable Assembly Removal	6-41
6.5.13.2	W1 Coaxial Cable Assembly Replacement	6-41
6.5.14	W2 Coaxial Cable Assembly Removal and Replacement	6-43
6.5.14.1	W2 Coaxial Cable Assembly Removal	6-43
6.5.14.2	W2 Coaxial Cable Assembly Replacement	6-43
CHAPTER 7 – PARTS LIST		
7.1	INTRODUCTION	7-1
7.2	SHOP REPLACEABLE UNITS	7-1
7.3	PARTS LISTS	7-5
7.4	COMPONENT LOCATION AND ASSEMBLY DIAGRAMS	7-6
CHAPTER 8 – INSTALLATION		
8.1	INTRODUCTION	8-1
8.2	SITE INFORMATION	8-1
8.2.1	General	8-1
8.2.2	General Guidelines	8-1
8.2.3	Grounding	8-2
8.2.4	Dimension and Weight Information	8-2
8.2.5	Environmental	8-4
8.3	TOOLS AND MATERIALS REQUIRED	8-4
8.4	UNPACKING AND REPACKING	8-4
8.4.1	Unpacking	8-4
8.4.2	Repacking	8-4
8.5	SITE INSTALLATION	8-4
8.5.1	Power Requirements	8-4
8.5.2	Ancillary Items Kit	8-4
8.5.3	Interconnect Diagrams	8-5
8.5.4	Jumper/DIP Switch Settings	8-5
8.5.5	Unit Removal and Installation Procedures	8-5
8.5.6	Access Clearance and Ventilation Requirements	8-5
8.5.7	Mounting	8-5
8.6	INSTALLATION CHECKOUT	8-7
8.6.1	Phase 1 – Hot Test Bed Installation Inspection and Pre-Power Up Procedures	8-7
8.6.2	Phase 2 – Initial Turn-On and Preliminary Tests	8-7
8.6.3	Phase 3 – Installation Verification Test	8-7

TABLE OF CONTENTS – Continued

Paragraph		Page
CHAPTER 9 – ACCESSORIES		
9.1	INTRODUCTION	9-1
9.1.1	Support Packages	9-1
9.1.1.1	Extended Warranties and Service Contracts	9-3
9.1.1.2	Training	9-3
9.1.1.3	Tools	9-3
9.1.1.4	Test Measurement Equipment	9-4
9.1.1.5	Maintenance Aids	9-4
9.1.1.6	Manuals	9-4
9.1.1.7	Spares Kits	9-5
9.1.1.8	Hot Test Bed Kits	9-5
9.1.2	Equipment Accessories	9-6

LIST OF FIGURES

Figure		Page
1-1	RT-1694 Receiver-Transmitter	1-0
1-2	Typical Maintenance Flow Chart	1-4
1-3	RT-1694(P) Family Tree	1-7
1-4	RT-1694B(P)/U Family Tree	1-9
1-5	Receiver-Transmitter in Manpack Configuration	1-11
1-6	Receiver-Transmitter in Vehicular Configuration	1-12
1-7	Locations of Assemblies	1-25
2-1	Receiver-Transmitter Front Panel	2-1
2-2	Sample Fault Code Display	2-3
3-1	Receiver-Transmitter Analog Clear Voice Functional Block Diagram	3-3
3-2	Receiver-Transmitter Unencrypted Digital Voice Functional Block Diagram	3-7
3-3	Receiver-Transmitter AVS Simplified Functional Block Diagram	3-9
3-4	Receiver-Transmitter Encrypted Digital Data Simplified Functional Block Diagram	3-15
3-5	Receiver-Transmitter Encrypted Digital Voice Simplified Functional Block Diagram	3-17
3-6	Receiver-Transmitter ALE Simplified Functional Block Diagram	3-19
3-7	Receiver-Transmitter Frequency Hopping Simplified Functional Block Diagram	3-23
3-8	Receiver-Transmitter Frequency Modulation Simplified Functional Block Diagram	3-27
4-1	Receive Sensitivity Test Set Up	4-4
4-2	Power Output Measurement Test Set Up	4-6
4-3	Transmit Frequency Measurement Test Set Up	4-8
4-4	BT1 Lithium Battery Test Set Up	4-10
5-1	Troubleshooting Process Used in this Chapter	5-1
5-2	Hot Test Bed Equipment Interconnect Diagram	5-2
5-3	Non-BIT Fault Logic Diagram	5-9
5-4	RF/IF/Audio/Digital/Control Signal Path Diagram	5-39

LIST OF FIGURES – Continued

Figure		Page
5-5	Power Distribution Diagram	5-41
5-6	Receiver-Transmitter Interconnect Schematic Diagram	5-45
6-1	Receiver-Transmitter Master Connection and Hardware Locations	6-7
6-2	MP2 Radio Case and Gasket Assembly Removal and Replacement	6-10
6-3	MP3 PWB Compartment Cover Removal and Replacement	6-12
6-4	A1A1 Interface PWB Assembly and A1A2 Encryption PWB Assembly Connector and Hardware Locations	6-15
6-5	A3 LPC Vocoder Assembly Connector and Hardware Locations	6-17
6-6	A4 Signal Processor PWB Assembly Connector and Hardware Locations ..	6-19
6-7	A5 Receiver/Exciter Assembly Connector and Hardware Locations	6-21
6-8	A6 Synthesizer Assembly Connector and Hardware Locations	6-23
6-9	A7 Power Supply Assembly Connector and Hardware Locations	6-25
6-10	A8 PA/Battery Charger Assembly Connector and Hardware Locations	6-29
6-11	A9 Antenna Coupler Assembly Connector and Hardware Locations	6-33
6-12	A10 Front Panel Assembly Connector and Hardware Locations	6-37
6-13	A11 Motherboard Assembly Hardware and Connector Locations	6-40
6-14	W1 Coaxial Cable Assembly Removal and Replacement	6-42
6-15	W2 Coaxial Cable Assembly Removal and Replacement	6-44
7-1	Receiver-Transmitter Illustrated Parts List	7-3
7-2	A1A1 Interface PWB Assembly Component Location Diagram (10303-2280)	7-7
7-3	A1A2 Encryption PWB Assembly Component Location Diagram (10303-2240)	7-8
7-4	A3 LPC Vocoder Assembly Component Location Diagram (10372-3440)	7-9
7-5	A4 Signal Processor PWB Assembly Component Location Diagram (10303-2500) (RT-1694(P) Configuration)	7-10
7-6	A4 Signal Processor PWB Assembly Component Location Diagram (10530-2500) (RT-1694B(P)/U Configuration)	7-11
7-7	A5A1 Second and Third Converter PWB Assembly Component Location Diagram (10303-2610)	7-12
7-8	A5A2 First Converter PWB Assembly Component Location Diagram (10303-2270)	7-13
7-9	A6A1 Reference Generator PWB Assembly Component Location Diagram (10303-2710)	7-14
7-10	A6A2 Synthesizer PWB Assembly Component Location Diagram (10303-2720)	7-15
7-11	A7 Power Supply Assembly Component Location Diagram (10303-2200)	7-16
7-12	A8A1 PA/Battery Charger PWB Assembly Component Location Drawing (10303-2130) (RT-1694(P) Configuration)	7-17
7-13	A8A1 PA/Battery Charger PWB Assembly Component Location Drawing (10530-2130) (RT-1694B(P)/U Configuration)	7-18
7-14	A8A2 Harmonic Filter PWB Assembly Component Location Diagram (10303-2140)	7-19
7-15	A9A1 Coupler Input PWB Assembly Component Location Diagram (10303-2150)	7-20

LIST OF FIGURES – Continued

Figure		Page
7-16	A10A1 Audio/Control PWB Assembly Component Location Diagram (10303-2100)	7-21
7-17	A11 Motherboard Assembly Component Location Diagram (10303-2170)	7-22
7-18	W1 RF Cable Assembly (PA-Coupler) Component Location Diagram (10372-1037)	7-23
7-19	W2 RF Cable Assembly (PA-Receiver/Exciter) Component Location Diagram (10372-1053)	7-24
8-1	Receiver-Transmitter Dimensions	8-3
8-2	Typical Hot Test Bed Interconnect Diagram	8-6

LIST OF TABLES

Table		Page
1-1	Receiver-Transmitter Specifications	1-13
1-2	High-Speed Data Modem Specifications	1-16
1-3	Automatic Link Establishment (ALE) Specifications	1-18
1-4	Voice Processor Specifications	1-20
1-5	Frequency Hopping Specifications	1-21
1-6	Digital Encryption Specifications	1-22
1-7	Assemblies and Reference Designators	1-23
1-8	List of Manufacturers	1-27
1-9	Test Equipment Required, But Not Supplied	1-28
1-10	Master Required Tools and Materials List	1-28
1-11	Hot Test Bed Items	1-29
2-1	Receiver-Transmitter Module Code/Assembly Index	2-3
2-2	Initial Settings and Executing BIT	2-4
2-3	Executing BIT After Run-Time Fault	2-5
2-4	Receiver-Transmitter/Power Amplifier Shutdown Procedure	2-6
4-1	Scheduled Maintenance Procedures	4-1
4-2	Receive Sensitivity Test Required Equipment	4-2
4-3	Power Output Measurement Required Equipment	4-5
4-4	Receiver-Transmitter Settings for Power Output Test	4-6
4-5	Transmit Frequency Measurement Required Equipment	4-7
4-6	Receiver-Transmitter Settings for Power Output Test	4-7
4-7	Lithium Battery Check Required Equipment	4-9
5-1	Hot Test Bed Required Equipment	5-2
5-2	Maintenance Turn-On Procedure	5-3
5-3	Non-BIT Fault Symptoms	5-4
5-4	Receiver-Transmitter Fault Codes and Suspected Assemblies	5-6
5-5	Protective Device Index	5-37
5-6	Troubleshooting Index	5-37
5-7	Self-Diagnostics Sequence Summary	5-66
6-1	SRUs and Removal and Replacement Paragraph References	6-1
6-2	Master Tools and Materials List	6-2
6-3	Receiver-Transmitter Cable Information	6-4

LIST OF TABLES – Continued

Table		Page
7-1	List of Shop Replaceable Units	7-1
7-2	Miscellaneous Items Parts List	7-5
7-3	List of Attaching Hardware	7-6
8-1	Receiver-Transmitter Dimensions	8-2
8-2	Hot Test Bed Items	8-5
9-1	Receiver-Transmitter Support Packages	9-2
9-2	Receiver-Transmitter Accessories	9-6

SAFETY SUMMARY

1. INTRODUCTION

All operators and maintenance personnel must observe the following safety precautions during operation and maintenance of this equipment. Specific warnings and cautions are provided in the manual and at the end of this Safety Summary. Warnings, Cautions, and Notes appear before various steps in the manual and will be used as follows:

- **WARNING** – Used when injury or death to personnel and damage to equipment is possible
- **CAUTION** – Used when there is a possibility of damage to equipment
- **NOTE** – Used to alert personnel to a condition that requires emphasis

2. PERSONNEL AND EQUIPMENT SAFETY

Basic safety precautions consider factors involved in protecting personnel from injury or death. Electrical, mechanical, electromagnetic radiation (EMR), material, or chemical hazards are the most common types of hazards found in electronic equipment. The following are types of hazards that may exist:

- ELECTRICAL** – Hazardous voltage and current levels may exist throughout the equipment. Contact with these hazards could cause electrocution, electrical shock, burns, or injury due to involuntary reflexes of the body.
- MECHANICAL** – Mechanical hazards are created when heavy assemblies and components must be removed and replaced. Moving parts (such as fan blades) and hot surfaces are potential mechanical hazards.
- THERMAL** – Burn hazards may exist in the equipment that could cause personal injuries and/or serious equipment damage. Internal surfaces of the equipment may be in excess of 65°C, the point at which personnel could be burned. Extreme caution should be used when working with any hot assemblies (for example, power supply or power amplifier assemblies). Physical injury or damage may result to personnel and/or equipment as a result of a reflex action to a burn.
- CHEMICAL** – Chemicals or materials used for servicing the equipment may present potential hazards. Many chemical agents, such as cleaners and solvents, may be toxic, volatile, or flammable. If used incorrectly, these agents can cause injury or death.
- EMR** – Overexposure to electromagnetic radiation results from amplified radio frequencies may produce a health hazard.

3. OPERATIONAL AND MAINTENANCE SAFETY GUIDELINES

Good safety discipline is critical to prevent injury to personnel. All other safety measures are useless if personnel do not observe the safety precautions and do not follow safety disciplines. Once aware of a hazard, personnel should ensure that all other personnel are aware of the hazard. The following basic safety disciplines are stressed:

- a. Read a procedure entirely before performing it. Personnel must always perform each assigned task in a safe manner.
- b. Prior to applying equipment power after maintenance, personnel must ensure that all unsecured hand tools and test equipment are disconnected from the serviced/maintained equipment and properly stored.

- c. Power to the equipment must be removed before a piece of equipment is removed.
- d. Extreme care must be used when adjusting or working on operating equipment. Voltages in excess of 70 V or current sources in excess of 25 A are covered with barriers. Barriers include warning information about the hazard encountered upon barrier removal.
- e. Personnel must react when someone is being electrically shocked. Perform the following steps:
 - 1. Shut off power.
 - 2. Call for help.
 - 3. Administer first aid if qualified.

Under no circumstances should a person come directly in contact with the body unless the power has been removed. When immediate removal of the power is not possible, personnel must use a non-conductive material to try to jolt or pry the body away from the point of shock.

- f. Personnel should work with one hand whenever possible to prevent electrical current from passing through vital organs of the body. In addition, personnel must never work alone. Someone must be available in the immediate area to render emergency first aid, if necessary.
- g. Lifting can cause injury. Items weighing more than 37 pounds must be lifted by two or more people.
- h. Some electrolytic capacitors contain aluminum oxide or tantalum. If connected incorrectly, the capacitor will explode when power is applied. Extreme care must be used when replacing and connecting these capacitors. The capacitor terminals must always be connected using the correct polarity: positive to positive and negative to negative.

The next section contains general safety precautions not directly related to specific procedures or equipment. These precautions are oriented toward the maintenance technician. However, all personnel must understand and apply these precautions during the many phases of operation and maintenance of the equipment. The following precautions must be observed:

DO NOT SERVICE EQUIPMENT ALONE

Never work on electrical equipment unless another person familiar with the operation and hazards of the equipment is near. When the maintenance technician is aided by operators, ensure that operators are aware of the hazards.

GROUNDING

Always ensure that all equipment and assemblies are properly grounded when operating or servicing.

TURN OFF POWER AND GROUND CAPACITORS

Whenever possible, power to equipment should be turned off before beginning work on the equipment. Be sure to ground all capacitors that are potentially dangerous.

KEEP AWAY FROM LIVE CIRCUITS

Operators and maintainers must observe all safety regulations at all times. Do not change components or make adjustments inside equipment with a high voltage supply on unless required by the procedure. Under certain conditions, dangerous potentials may exist in circuits with power controls off, due to charges retained by capacitors.

DO NOT BYPASS INTERLOCKS

Do not bypass any interlocks unnecessarily. If it is necessary to employ an interlock bypass for equipment servicing, use extreme care not to come in contact with hazardous voltages.

USE CARE HANDLING HEAVY EQUIPMENT

Never attempt to lift large assemblies or equipment without knowing their weight. Use enough personnel or a mechanical lifting device to properly handle the item without causing personal injury.

HEED WARNINGS AND CAUTIONS

Specific warnings and cautions are provided to ensure the safety and protection of personnel and equipment. Be familiar with and strictly follow all warnings and cautions on the equipment and in technical manuals.

PROTECTIVE EYEWEAR

All personnel must wear protective eyewear when servicing or maintaining equipment. Protective eyewear must be worn at all times when using tools.

4. PROTECTION OF STATIC-SENSITIVE DEVICES



Diode input-protection is provided on all CMOS devices. This protection is designed to guard against adverse electrical conditions such as electrostatic discharge. Although most static-sensitive devices contain protective circuitry, several precautionary steps should be taken to avoid the application of potentially damaging voltages to the inputs of the device.

To protect static-sensitive devices from damage, the following precautions should be observed.

- a. Keep all static-sensitive devices in their protective packaging until needed. This packaging is conductive and should provide adequate protection for the device. Storing or transporting these devices in conventional plastic containers could be destructive to the device.
- b. Disconnect power prior to insertion or extraction of these devices. This also applies to PWBs containing such devices.
- c. Double check test equipment voltages and polarities prior to conducting any tests.
- d. Avoid contact with the leads of the device. The component should always be handled carefully by the ends or side opposite the leads.
- e. Avoid contact between PWB circuits or component leads and synthetic clothing.
- f. Use only soldering irons and tools that are properly grounded. Ungrounded soldering tips or tools can destroy these devices. **SOLDERING GUNS MUST NEVER BE USED.**

5. EXPLANATION OF HAZARD SYMBOLS



The symbol of drops of a liquid onto a hand shows that the material will cause burns or irritation of human skin or tissue.



The symbol of a person wearing goggles shows that the material will injure your eyes.



The symbol of a flame shows that a material can ignite and burn you.



The symbol of a skull and crossbones shows that a material is poisonous or a danger to life.



The symbol of a human figure in a cloud shows that vapors of a material present danger to your life or health.

RT-1694

RECEIVER-TRANSMITTER

INTERMEDIATE MAINTENANCE
MANUAL

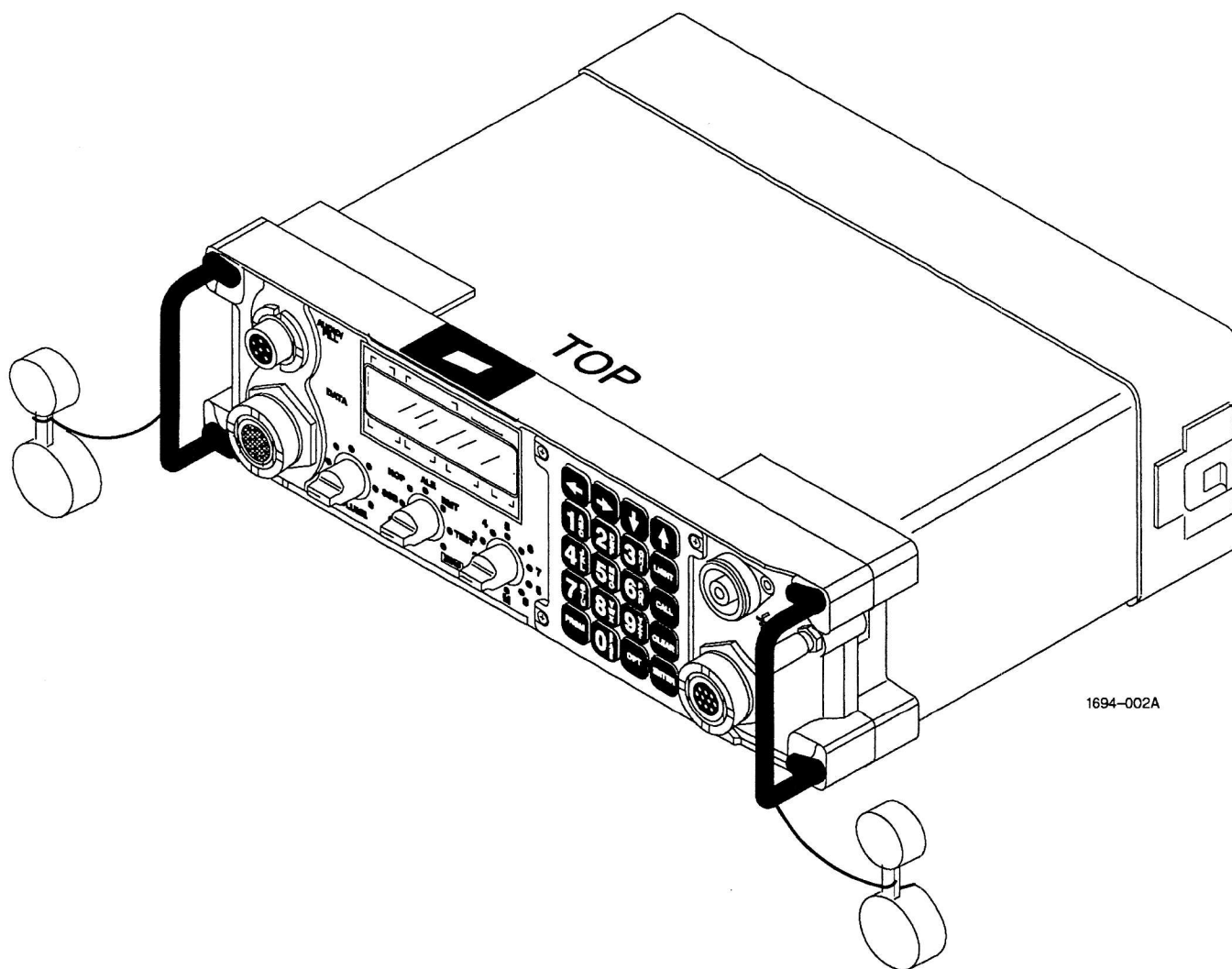

1694-002A

Figure 1-1. RT-1694 Receiver-Transmitter

CHAPTER 1

GENERAL INFORMATION

1.1 SAFETY PRECAUTIONS

All safety precautions necessary for the protection of personnel and equipment are cross-referenced in the following list. The **WARNING** or **CAUTION** is referenced to the paragraph number where it is used in the manual, and a brief subject phrase indicating the content is provided. Read these items in their entirety before performing the referenced procedure.

- **CAUTION** – Paragraph 4.2.1.2 – If power amplifier is installed, provide adequate RF protection for signal generator.
- **WARNING** – Paragraph 6.3.1 – High voltages present if power is not removed
- **CAUTION** – Paragraph 6.3.2 – Use precautions when handling electrostatic sensitive devices.
- **CAUTION** – Paragraph 6.3.5 – Use correct tool.
- **CAUTION** – Paragraph 6.3.6 – Caution on damaging wires, cables, or connectors during repair
- **WARNING** – Paragraph 6.4.2.1 – High voltages present if power is not removed
- **WARNING** – Paragraph 6.4.2.2 – High voltages present when applying power
- **WARNING** – Paragraph 6.5.1 – Remove electrical connections to receiver-transmitter before removing and replacing assemblies.
- **WARNING** – Paragraph 6.5.2 – Remove electrical connections to receiver-transmitter before removing and replacing assemblies.
- **WARNING** – Paragraph 6.5.3 – Remove electrical connections to receiver-transmitter before removing and replacing assemblies.
- **CAUTION** – Paragraph 6.5.3 – Use precautions when handling electrostatic sensitive devices.
- **WARNING** – Paragraph 6.5.4 – Remove electrical connections to receiver-transmitter before removing and replacing assemblies.
- **CAUTION** – Paragraph 6.5.4 – Use precautions when handling electrostatic sensitive devices.
- **WARNING** – Paragraph 6.5.5 – Remove electrical connections to receiver-transmitter before removing and replacing assemblies.
- **CAUTION** – Paragraph 6.5.5 – Use precautions when handling electrostatic sensitive devices.
- **WARNING** – Paragraph 6.5.6 – Remove electrical connections to receiver-transmitter before removing and replacing assemblies.
- **CAUTION** – Paragraph 6.5.6 – Use precautions when handling electrostatic sensitive devices.
- **WARNING** – Paragraph 6.5.7 – Remove electrical connections to receiver-transmitter before removing and replacing assemblies.

- CAUTION – Paragraph 6.5.7 – Use precautions when handling electrostatic sensitive devices.
- WARNING – Paragraph 6.5.8 – Remove electrical connections to receiver-transmitter before removing and replacing assemblies.
- CAUTION – Paragraph 6.5.8 – Use precautions when handling electrostatic sensitive devices.
- WARNING – Paragraph 6.5.9 – Remove electrical connections to receiver-transmitter before removing and replacing assemblies.
- CAUTION – Paragraph 6.5.9 – Use precautions when handling electrostatic sensitive devices.
- CAUTION – Paragraph 6.5.9.1 – Do not overextend W2 Coaxial Cable Assembly.
- WARNING – Paragraph 6.5.10 – Remove electrical connections to receiver-transmitter before removing and replacing assemblies.
- CAUTION – Paragraph 6.5.10 – Use precautions when handling electrostatic sensitive devices.
- WARNING – Paragraph 6.5.11 – Remove electrical connections to receiver-transmitter before removing and replacing assemblies.
- CAUTION – Paragraph 6.5.11 – Use precautions when handling electrostatic sensitive devices.
- WARNING – Paragraph 6.5.12 – Remove electrical connections to receiver-transmitter before removing and replacing assemblies.
- CAUTION – Paragraph 6.5.12 – Use precautions when handling electrostatic sensitive devices.
- WARNING – Paragraph 6.5.13 – Remove electrical connections to receiver-transmitter before removing and replacing assemblies.
- WARNING – Paragraph 6.5.14 – Remove electrical connections to receiver-transmitter before removing and replacing assemblies.
- WARNING – Paragraph 8.2.3 – Do not daisy-chain ground connections.

1.2 MAINTENANCE LEVELS

1.2.1 Introduction

Harris RF Communications designs its products and systems to be supported by up to four maintenance levels. See Figure 1-2. Each maintenance level relies on a defined set of support documentation and equipment in order to fulfill its maintenance tasks. The tasks performed at each level grow in complexity as fault isolation is narrowed to the component causing the fault. This concept assists the maintainer by supplying only the information and materials required for that maintenance level. These levels may be combined to sustain any particular user maintenance philosophy.

1.2.1.1 Level I

This level is restricted to fault recognition and detection. Fault isolation is not usually performed at this level. An operator who detects a faulty condition alerts Maintenance Level II for repair.

1.2.1.2 Level II

The maintenance technician repairs the radio system by utilizing a System (Level II) manual to fault isolate to the faulty unit (for example, receiver-transmitter, power amplifier, antenna coupler, etc.). The faulty Line Replaceable Unit (LRU) is replaced with a spare and sent to Maintenance Level III.

1.2.1.3 Level III

The faulty unit is serviced at a facility that has support equipment available, typically a hot test bed radio system. The suspected faulty unit is inserted into the hot test bed radio system and troubleshot down to the faulty assembly using a Maintenance (Level III) manual. The faulty Shop Replaceable Unit (SRU) is replaced with a spare and passed to Maintenance Level IV.

1.2.1.4 Level IV

The faulty SRU is returned to Harris/RF Communications for repair. If Level IV maintenance capabilities are available on-site, the maintenance technician can identify the faulty component on the SRU using a Depot Maintenance (Level IV) manual that outlines the electronic maintenance techniques and test fixtures necessary to repair the SRU.

1.2.2 Purpose of this Manual

This manual provides the user with all technical information required to support Level III maintenance as described in Paragraph 1.2.1.3.

The overall intent of this manual is to help the maintainer expedite repair of the unit in a reasonable amount of time, resulting in reduced down-time and increased system availability. Detailed information that will be useful to the maintainer is provided: unit configuration, equipment specifications, fault isolation and repair techniques, required tools and test equipment, and functional descriptions of assemblies.

1.2.3 Maintenance Support Packages

Harris RF Communications designs maintenance packages that support these levels. Packages include the necessary spare parts, training, technical manuals, tools, test equipment, and maintenance aids such as interface cables, extender cards, and test fixtures.

Refer to Chapter 9, Accessories, for more information on support packages designed to enhance the effectiveness of this unit.

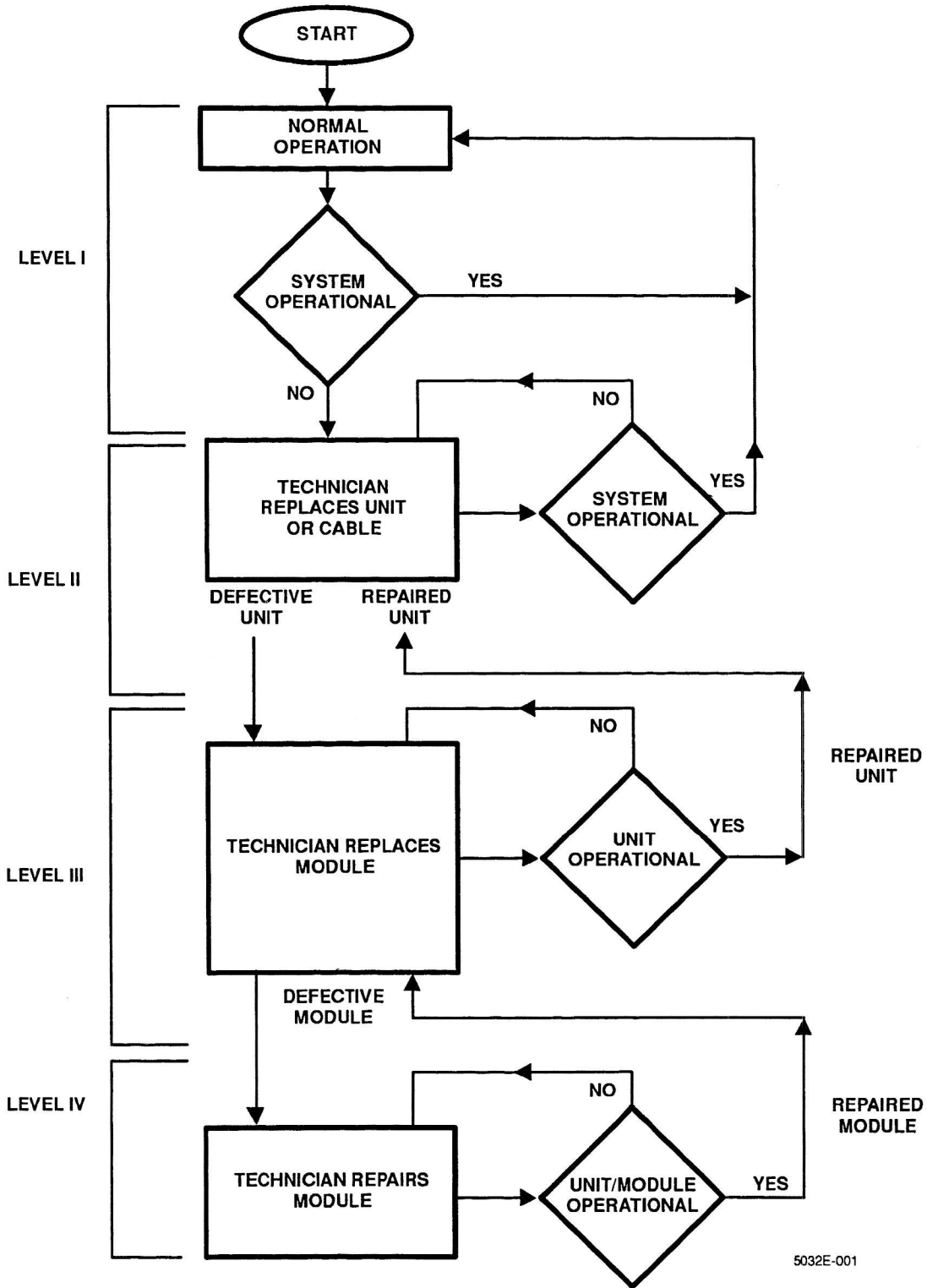

Figure 1-2. Typical Maintenance Flow Chart

1.2.4 Scope

This manual contains operation information, functional description, scheduled maintenance, troubleshooting, corrective maintenance, parts lists, and installation information for the Receiver-Transmitter (R/T). This publication does not supersede any previous manual or technical documentation. The information contained in this manual applies to the RT-1694(P) and the RT-1694B(P)/U configurations of the receiver-transmitter.

1.2.5 Warranty

Harris Corporation guarantees that if the receiver-transmitter fails from normal use within one year from the date of shipment due to a defect in workmanship or materials, Harris will repair or replace the receiver-transmitter at no charge. Repairs made by Harris to the receiver-transmitter under this warranty are warranted to be free from defects in material and workmanship for 60 days from the date of repair.

For information on how to process a claim under this warranty, and on what is not covered by this warranty, refer to the warranty information printed on the inside front cover of this manual.

1.3 GENERAL EQUIPMENT DESCRIPTION

1.3.1 General

Figure 1-1 shows the receiver-transmitter.

The receiver-transmitter operates from 1.6 MHz to 59.9999 MHz. All functions are controlled from the front panel of the receiver-transmitter, or from a remote terminal. Optional modules are installed in the chassis.

1.3.2 Front Panel

A 32-character, alphanumeric display provides system status and reflects data entry to simplify operation and programming. The receiver-transmitter is also connected to the antenna and external system units via front panel connectors.

1.3.3 Rear Panel

When used in the manpack configuration, the battery case is attached to the rear panel of the receiver-transmitter.

1.3.4 Features

The receiver-transmitter has the following features:

- Frequency range of 1.6 MHz to 59.9999 MHz
- Lower Sideband (LSB), Upper Sideband (USB), Amplitude Modulation Equivalent (AME), Frequency Modulation (FM), and Continuous Wave (CW) modes of operation
- 100 preset channels available
- 50 ohm nominal, unbalanced Radio Frequency (RF) input/output impedance
- RS-232C or MIL-STD-188-114A Data Interface
- Optional plug-in modules (refer to Paragraph 1.3.5)
- 15 mW audio output to external handset

1.3.5 Configuration Information

Figure 1-3 shows the RT-1694(P) family tree, and Figure 1-4 shows the RT-1694B(P)/U family tree. These family trees identify all of the assemblies that make up a receiver-transmitter.

With the RT-1694(P) configuration, two plug-in modules are available to provide the exact radio features desired:

- RF-5161-01 Performance Option (A3 Linear Predictive Coding [LPC] Vocoder Assembly)
- RF-5170 Security Option (A1A2 Encryption Printed Wiring Board [PWB] Assembly)

NOTE

The RT-1694A(P) configuration includes the A3 LPC Vocoder Assembly and CARC paint.

For more information on these options, refer to Chapter 3, Functional Description.

1.3.5.1 Ancillary Kit

The receiver-transmitter is not supplied with an ancillary items kit.

1.3.5.2 Unit Identification

Receiver-transmitter identification information is located on the front panel identification tag. This tag contains model, part, and serial number information. See MP21 on Figure 7-1.

1.3.6 General System Relationship

Figure 1-5 shows the receiver-transmitter in the manpack configuration. Figure 1-6 shows the receiver-transmitter in the vehicular configuration. For information on installation variations, refer to Chapter 8, Installation. Also refer to the RF-5200 FALCON™ Series Tactical Communications Manpack System Manual (10515-0006-4200).

When used in the manpack configuration, batteries provide +24 Vdc to the receiver-transmitter. The exciter assembly provides a low-power RF signal to the power amplifier assembly. This assembly amplifies the signal up to 20 watts. The power amplifier assembly passes the amplified RF signal to the antenna coupler assembly, which passes the signal to the OE-505 Antenna.

When used in the vehicular configuration, the receiver-transmitter is the exciter and controller for an external power amplifier and antenna coupler. The vehicle alternator/battery system provides +28 Vdc to the power amplifier. The low-power exciter RF output is passed to the external power amplifier via the RT-1694-PA coax cable. The high-power RF output of the power amplifier is sent to the external antenna coupler via the PA-coupler coax cable. The receiver-transmitter communicates with the antenna coupler via the RT-1694-PA control cable and the PA-coupler control cable. For more system information, refer to Chapter 3, Functional Description.

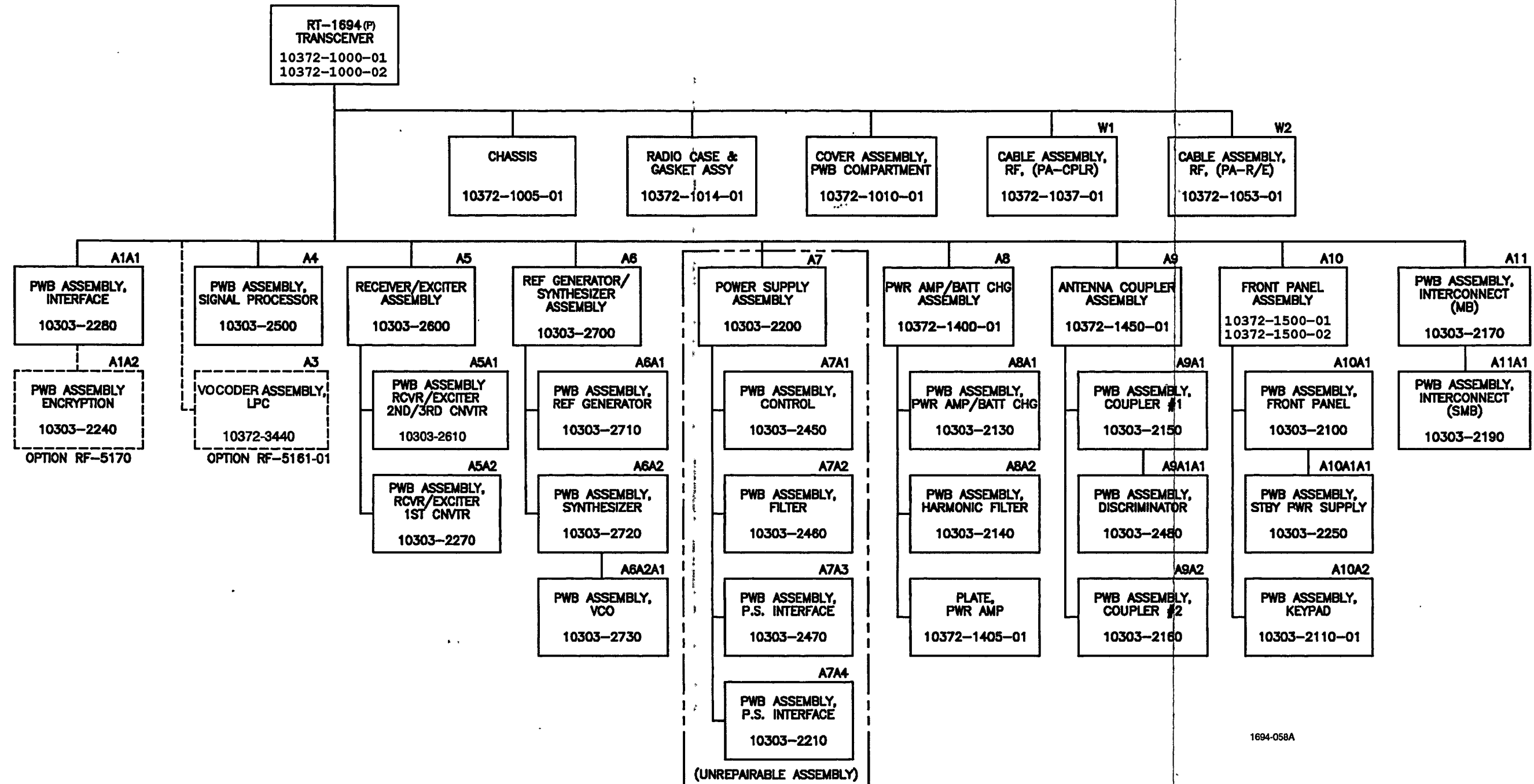

1694-058A

Figure 1-3. RT-1694(P) Family Tree

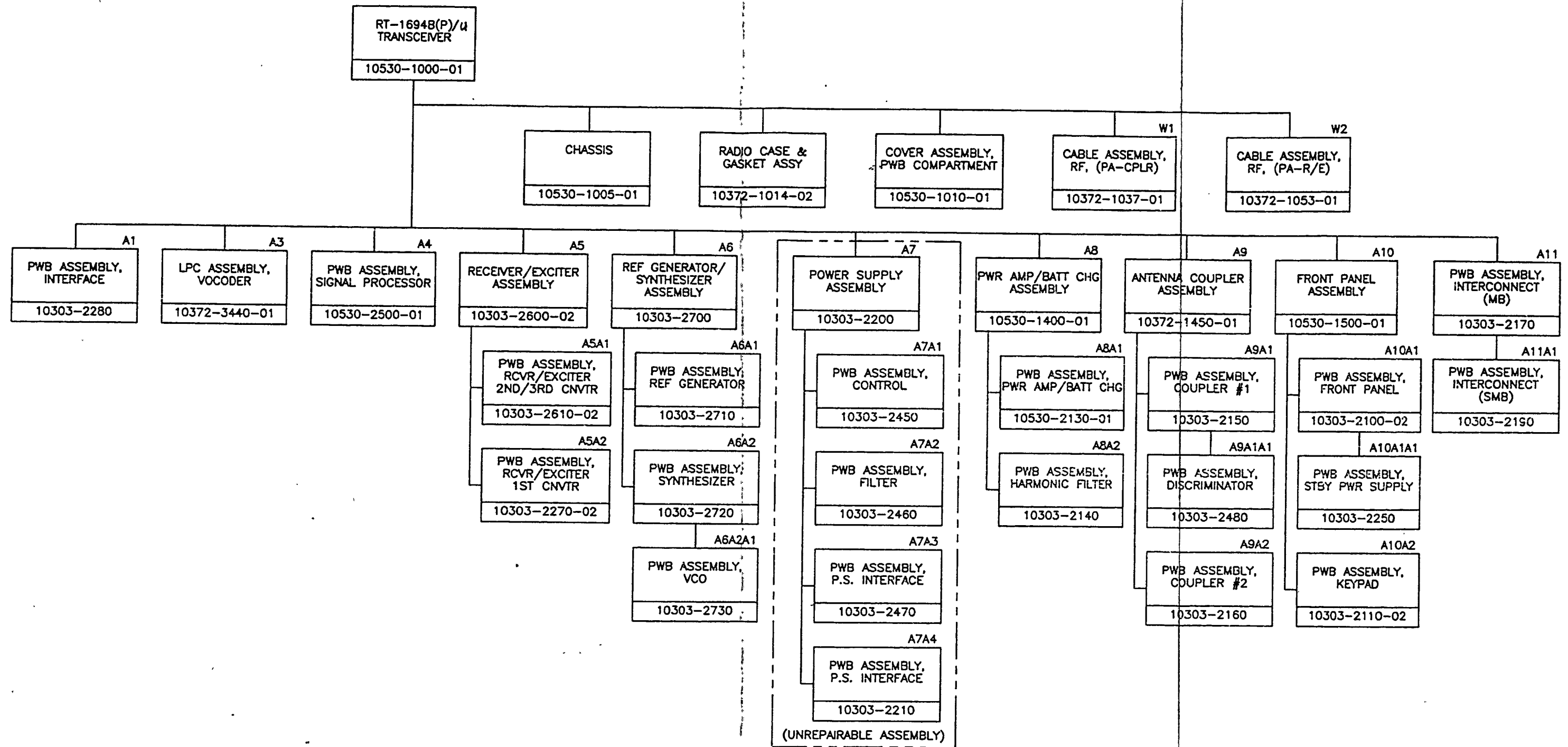

Figure 1-4. RT-1694B(P)/U Family Tree

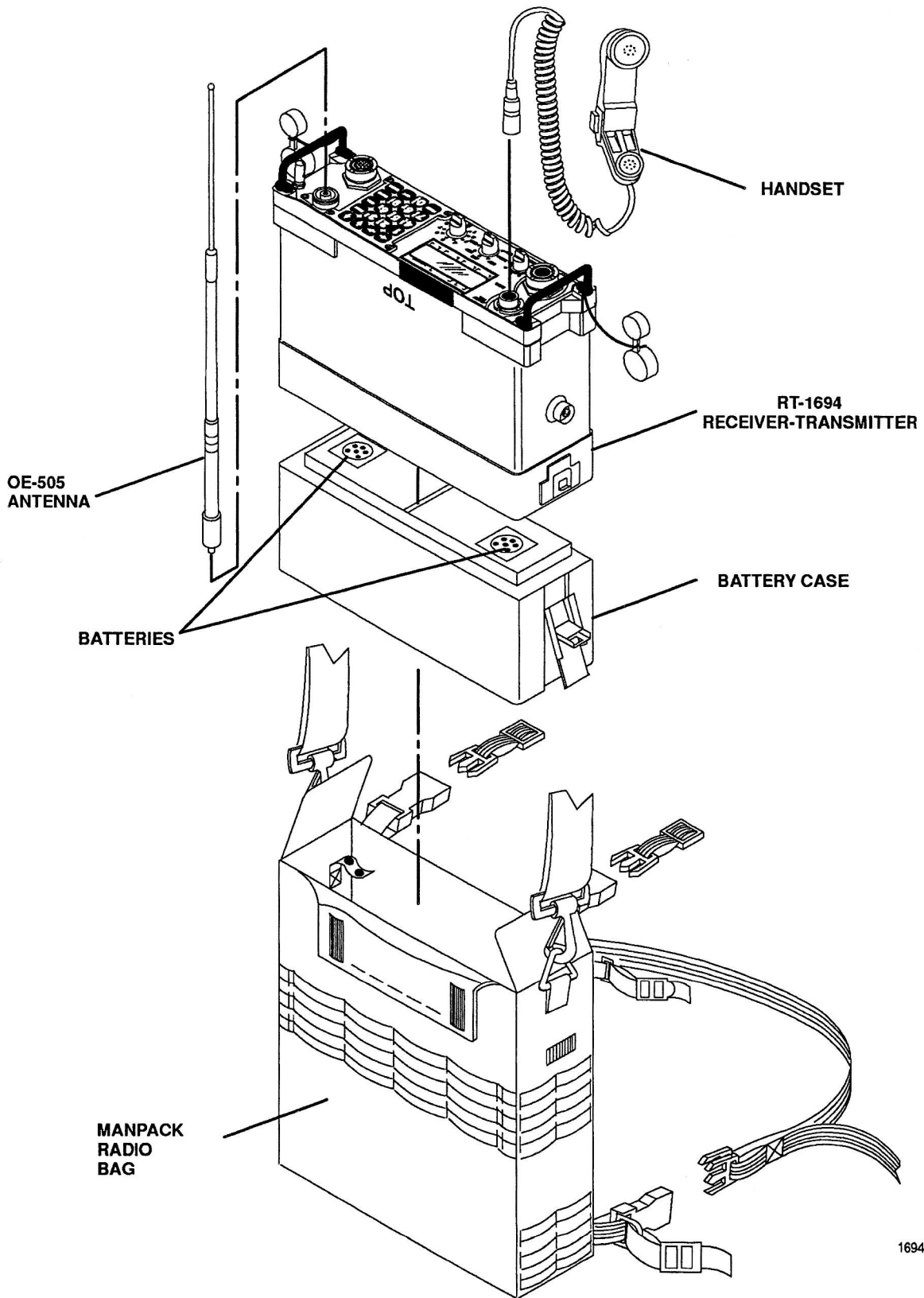

Figure 1-5. Receiver-Transmitter in Manpack Configuration

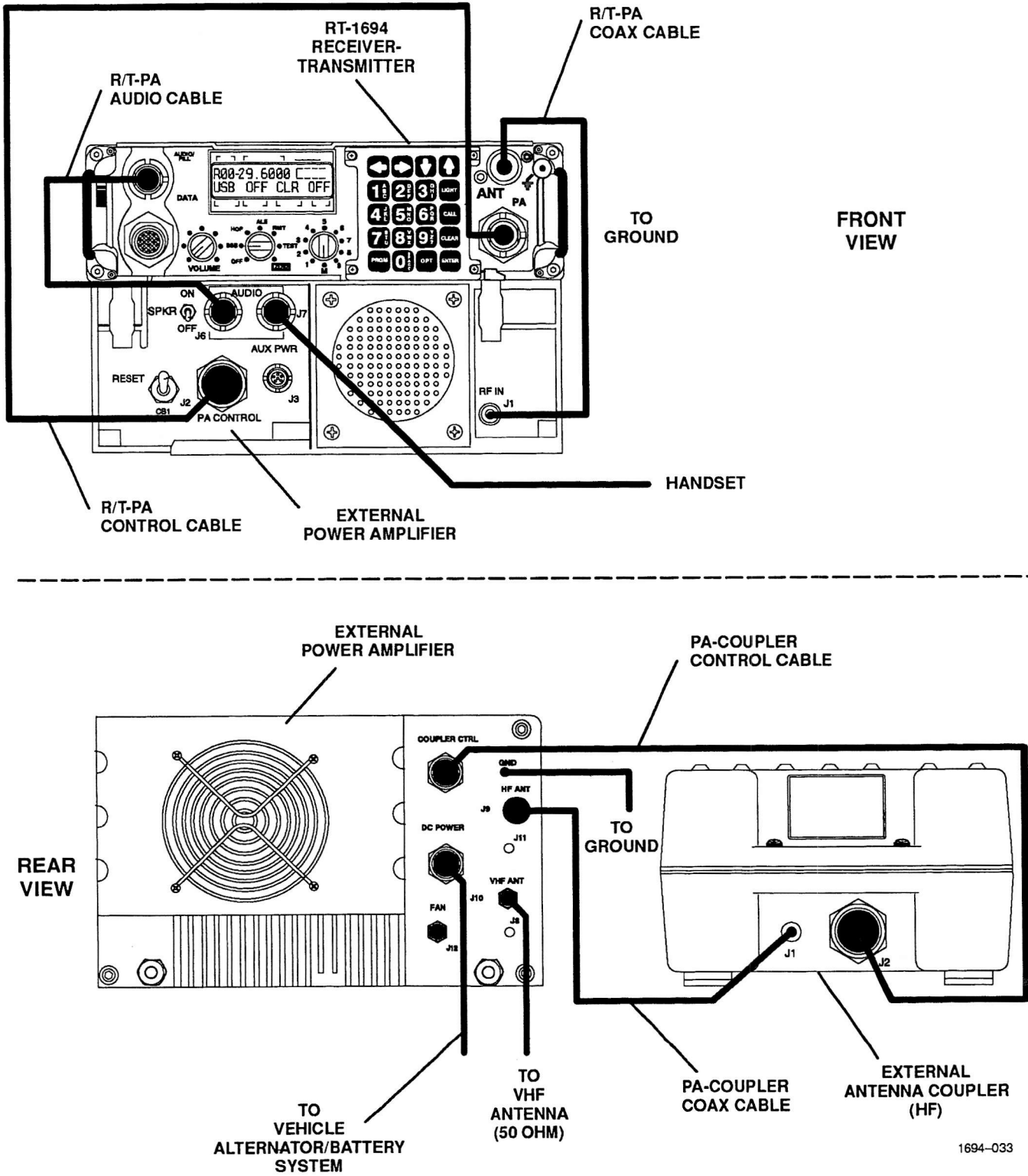

Figure 1-6. Receiver-Transmitter in Vehicular Configuration

1.3.7 Specifications

The following tables provide information covering the specifications of the receiver-transmitter, the RF-5161-01 Performance Option, and the RF-5170 Security Option. Refer to the following tables for specifications:

- Table 1-1 – Receiver-Transmitter Specifications
- Table 1-2 – High-Speed Data Modem Specifications
- Table 1-3 – Automatic Link Establishment (ALE) Specifications
- Table 1-4 – Voice Processor Specifications
- Table 1-5 – Frequency Hopping Specifications
- Table 1-6 – Digital Encryption Specifications

Table 1-1. Receiver-Transmitter Specifications

Function	Specification
GENERAL	
Frequency Range	1.6 to 59.9999 MHz
Preset Channels	100
Frequency Stability	$\pm 1 \times 10^{-6}$
Modes of Operation	J3E (single sideband, upper or lower, suppressed carrier telephony) H3E (compatible Amplitude Modulation [AM] single sideband plus full carrier) J2A (CW single sideband suppressed carrier) F3E (FM telephony)
RF Input/Output Impedance	50 ohms nominal, unbalanced
Power Input	+24 Vdc
Antenna Tuning Capability	50 ohm output: 1.6 to 60 MHz 8, 10, 16 ft. whips: 1.6 to 60 MHz AS-2259/GR (RF-1936): 3.5 to 30 MHz RF-1940 Tactical Dipole: 3 to 30 MHz
Data Interfaces	Synchronous and Asynchronous RS-232C and MIL-STD-188-114A
Temperature Range	-40° C to +70° C (-40° F to +158° F)
Environmental	MIL-STD-810E
Size	RT-1694 only: 26.4 W x 21.6 D x 7.8 H cm (10.4 W x 8.5 D x 3.1 H in.) With battery case: 26.4 W x 33.8 D x 7.8 H cm (10.4 W x 13.3 D x 3.1 H in.)

Table 1-1. Receiver-Transmitter Specifications – Continued

Function	Specification
Weight Optional Modules [RT-1694(P)] Optional Modules [RT-1694B(P)/U]	RT-1694(P): 3.86 kg (8.5 lbs.) without battery 7.71 kg (17 lbs.) with case and two Nickel-Cadmium (Ni-Cd) batteries RT-1694B(P)/U: 3.38 kg (7.45 lbs.) without battery case 5.91 kg (13.02 lbs.) with case and two lithium batteries RF-5161-01 Performance Option (A3 LPC Vocoder Assembly); RF-5170 Security Option (A1A2 Encryption PWB Assembly) RF-5170 Security Option (A1A2 Encryption PWB Assembly) <p style="text-align: center;">NOTE</p> The RF-5161-01 is standard equipment for the RT-1694A(P) and RT-1694B(P)/U configurations.
RECEIVER	
Sensitivity (without preamplifier) Audio Output Squelch Image and Intermediate Frequency (IF) Rejection Spurious Responses Automatic Gain Control (AGC) Characteristics Intermodulation Distortion Overload Protection	Single Sideband (SSB): -110 dBm (0.7 uV) for 10 dB SINAD (2.7 kHz bandwidth) AM: -98 dBm (2.8 uV) for 10 dB SINAD (6 kHz bandwidth 30% modulation) CW: -117 dBm (0.3 uV) for 10 dB (S+N)/N (0.35 kHz bandwidth) FM: -107 dBm (1.0 uV) for 10 dB SINAD 15 mW at 1000 ohms into external handset Front panel selectable, 150 Hz subcarrier (FM) or RWAS (High Frequency [HF] SSB) Greater than 80 dB RT-1694(P): Less than 10 greater than -90 dBm equivalent input; fewer than 500 are greater than -120 dBm equivalent input RT-1694B(P)/U: Less than -112 dBm for 99% of available 3 kHz channels. Less than -100 dBm for 0.8%. For 0.2%, may exceed the above specifications. Mode dependent, selectable from front panel RT-1694(P): In band: -45 dB or better for two -20 dBm signals within the IF passband Out of band: -80 dB or better for two -35 dBm signals separated 100 kHz or more RT-1694B(P)/U: In band: -35 dB or better for two -6 dBm (0 dBm/Peak Envelope Power [PEP]) signals at rated audio output Out of band: Third order intercept point shall be +10 dBm or greater. Receiver protected to 70 Vrms

Table 1-1. Receiver-Transmitter Specifications – Continued

Function	Specification
TRANSMITTER	
Power Output	SSB, CW, AME: 1, 5, 20 watts PEP/Average
	FM: 1, 5, 10 watts
Carrier Suppression	Greater than 60 dB below PEP output (J3E mode)
Undesired Sideband Rejection	Greater than 60 dB below PEP output
Intermodulation Distortion	1.6 – 29.9999 MHz: -24 dBc minimum
	30.0 – 59.9999 MHz: -18 dBc minimum
Audio Input	Handset: 1.5 mVrms into 150 ohms
	Fixed Level: 0.774 Vrms into 600 ohms

NOTE

Because Harris engineers continuously strive to improve all aspects of Harris equipment, specifications are subject to change without notice.

Table 1-2. High-Speed Data Modem Specifications

Function	Specification
39-TONE MODE	
Data Rates Transmission Mode Forward Error Correction (FEC) Coding Interleaving Tone Library Modulation Demodulation Doppler Correction Channel Bandwidth	2400, 1200, 600, 300, 150, 75 bits per second (bps) Half duplex (14, 10, 2) Reed-Solomon Code at 2400 bps (7, 3, 2) Reed-Solomon Code at lower bps rates Four levels (short, long, alternate short, alternate long) 39 Tones, 675 to 2812.5 Hz, 56.25-Hz tone spacing; Doppler tracking tone: 393.75 Hz Time Differential Quaternary Phase Shift Keying (TDQPSK) (four phase) 128-point Fast Fourier Transform (FFT) 75 Hz, tracking up to 3.5 Hz per second 3000 Hz
SERIAL (SINGLE TONE) MODE (RT-1694B(P)/U ONLY)	
Data Rates FEC Coding Interleaving Delay Modulation Multipath Tolerance Bandwidth Doppler Sync Equalization Synchronization Adaptive Filtering	75 bps (Receiver [RX] and Transmit [TX]) 150, 300, 600, 1200, 2400 bps (TX only) Convolutional with Viterbi soft decision decoding 0, 1.2, or 9.6 seconds 8-ary Phase Shift Keying (PSK), 2400 symbols/second 6.5 milliseconds 3000 Hz (300 – 3300 Hz) ± 75 Hz Data Directed Equalization Sync on preamble Suppression of certain classes of in-band interference
BINARY FSK MODE	
Data Rate Transmission Mode Signaling FSK Modes	300, 150, 75 bps Half duplex Phase Continuous Binary Frequency Shift Keying (FSK) Front-Panel Selectable Wide Shift: 2000 Hz \pm 425 Hz (75, 150, 300 bps) Narrow Shift: 2805 Hz \pm 42.5 Hz (75 bps) Alternate: 2000 Hz \pm 85 Hz (75, 150 bps) Variable: Programmable mark/space: 350 Hz - 3000 Hz (75, 150, 300 bps)

Table 1-2. High-Speed Data Modem Specifications – Continued

Function	Specification
DATA INTERFACES	
Data	Asynchronous (4800, 2400, 1200, 600, 300, 150, 75 bps), American National Standard Code for Information Exchange (ASCII)
	Synchronous (2400, 1200, 600, 300, 150, 75 bps; internal or external clock)
Control	Request-To-Send (RTS), Clear-To-Send (CTS), XON-XOFF, CTRL-B (key), CTRL-C (unkey)
Electrical	RS-232C, MIL-STD-188-114A
Remote Control	Full function

Table 1-3. Automatic Link Establishment (ALE) Specifications

Function	Specification
PROGRAMMING	
Parameters	Radio channel groups, local addresses, individual (remote) addresses, network addresses, time of day, Link Quality Analysis (LQA) start time and repeat interval, antenna coupler tune time, link timeout
Retention	1 year minimum
CHANNELS	
Number	100 simplex and/or half duplex
Frequency Range	Operating: 1.6 to 59.9999 MHz
Modes	Full Performance: 1.6 to 30 MHz
Channel Scan Groups	USB, LSB, AME, FSK, CW, data, digital voice
	10
SCAN	
Rate	5 channels per second
Scanned Channels	100 channels maximum
Channel Scan Groups	10
SELECTIVE CALLING	
Types	Individual, net, all call may be placed from front panel or remote. Any calls, selective any calls, and wildcard calls may be placed from remote only. Group calls can be received, but not placed.
Channel Selection	Automatic or manual
Handshake	Three-way for individual, net, group, any, wildcard;
Other	One-way for allcalls
	Digital squelch, listen before transmit (ALE traffic only), key-to-call
ADDRESSES	
Format	1 to 15 character, alphanumeric
Local Addresses	20 maximum
Network Addresses	20 maximum
Individual Addresses	200 maximum

Table 1-3. Automatic Link Establishment (ALE) Specifications – Continued

Function	Specification
LINK QUALITY ANALYSIS	
Types	Sounding (one way) and exchange (three way handshake)
Measurement	Weighted average based on SINAD and Pseudo Bit Error Rate (PBER) as per MIL-STD-188-141A
Start Time	Immediate, or programmed time-of-day
Repeat Interval	One time, or interval (hours/minutes)
Addresses Queued	10 maximum
LQA Score Storage	100 channels x 200 addresses x 2 directions
SIGNALING	
Modulation	Phase continuous 8-ary FSK
Symbol Rate	125 baud
Bit Rate	375 bps
Coding	Golay FEC, 2/3 majority vote, interleaving
Calling Cycle	1 to 79 seconds (depending on call type, channels scanned, and call sign length)
BUILT-IN TEST	
Functions Tested	ALE, radio, power amplifier, antenna coupler
REMOTE CONTROL	
Interface	RS-232C
Rate	300 to 9600 baud asynchronous
Other	2 stop bits, 8 data bits, no parity ASCII character based (compatible with existing RF-5000 remote control)

Table 1-4. Voice Processor Specifications

Function	Specification
GENERAL	
Audio Input	Handset connector: 1.5 mVrms into 150 ohms; 600 ohm auxiliary connector: 0/-10 dBm
VOICE DIGITIZATION	
Algorithm	LPC-10-52E
Bit Rates	2400 (single channel) or 800 bps (frequency hopping)
Bit Error Tolerance	2 x 10 ⁻² random Bit Error Rate (BER) for Data Rate Transmission (DRT) greater than 80
Synchronization	Frame synchronization at beginning of message
Tracking	Continuous synchronization during message
End of Message	End of message data or loss of tracking data for two seconds
ANALOG VOICE SECURITY (AVS)	
Encryption Algorithm	Split band inversion with time diversity scrambling
Bands	24
Maximum Transmit Delay	0.5 second
Number of Codes	10 ⁺⁸

Table 1-5. Frequency Hopping Specifications

Function	Specification
Frequency Range	2.0 MHz to 29.9950 MHz
Hopping Restrictions	Wide Band and List modes not available when internal antenna coupler is enabled or external antenna coupler is attached.
Hop Rate	20 hops/second
Data Rate	75, 150, 300 bps
Forward Error Correction	Frequency diversity (all rates); 14, 10, 2 Reed-Soloman (75, 150, 300 bps)
Hop Nets	10 (synchronization on only one of the ten nets at a time)
Hopping Bandwidths	Wide Band: Programmable bandwidth: 70 kHz to 2 MHz Minimum lower frequency: 2.0 MHz Maximum upper frequency: 29.995 MHz Narrow Band: Center frequency: $15 \text{ MHz} \leq F_c \leq 29.995 \text{ MHz}$ Bandwidth: 300 kHz Narrowband (NB) spacing: 5 kHz Center frequency: $5 \text{ MHz} \leq F_c \leq 15 \text{ MHz}$ Bandwidth: 100 kHz NB spacing: 2.5 kHz Center frequency: $3.5 \text{ MHz} \leq F_c \leq 5 \text{ MHz}$ Bandwidth: 50 kHz NB spacing: 2.5 kHz Center frequency: $1.6 \text{ MHz} \leq F_c \leq 3.5 \text{ MHz}$ Bandwidth: 17.5 kHz (7.5 kHz – low; 10 kHz – high)
Frequency Spacing	Frequency List: Programmable bandwidth: 70 kHz to 2 MHz Minimum lower frequency: 2.0 MHz Maximum upper frequency: 29.995 MHz Wide Band Mode: 5 kHz Narrow Band Mode: 2.5 kHz, 5 kHz center frequency dependent Frequency List Mode: 5 kHz
Frequency List	15 to 100 frequencies
Hopset Exclusions	Sub-bands (10 total) – wideband hopping only
PN Generator	Non-linear, repeat cycle > 5 years
Initial Sync Time	29 seconds - required once per eight-hour period
Late Net Entry Time	29 seconds
In-Net Message Sync	Coarse Synchronization: continuous for up to eight hours Fine Synchronization: 300 millisecond typical after key-down
Excision Filtering	Excision of up to two single frequency interfering signals within the audio passband (typically provides greater than 25 dB equivalent filtering)

Table 1-6. Digital Encryption Specifications

Function	Specification
GENERAL	
Frequency Range	The radio is capable of operating in digital voice mode from 1.6 MHz to 59.9999 MHz and meets full performance specifications in this mode from 1.6 MHz to 29.9999 MHz.
Algorithm	LPC-10-52E
Bit Rates	2400 bps in single channel or 800 bps in frequency hopping
Synchronization	Frame synchronization at beginning of message
Tracking	Continuous synchronization during message
End of Message	End of message data or loss of tracking data for two seconds
PROGRAMMERS	
RF-5960 Master Code Programmer	The RF-5960 Master Code Programmer provides programming of the Data Encryption Option with six key codes with up to 1×10^{52} possible combinations in a portable configuration. Operates from 115/230 Vac, 50/60 Hz, or as a portable unit on an internal BB-590/U rechargeable Ni-Cd battery. The internal battery is automatically recharged when operated on Alternating Current (AC).
Available Codes	1×10^{52} possible settings
Power	115/230 Vac, 50/60 Hz, or internal BB-590/U rechargeable Ni-Cd battery
Size	5.38 H x 7.5 W x 8.5 D in. (11.8 H x 16.5 W x 18.7 D cm)
Weight	11.5 lbs (29 kg)
RF-5961 Field Code Programmer	The RF-5961 Field Code Programmer is a pocket-sized unit that permits programming of the Digital Encryption Unit option (each with six key codes having up to 10^{52} combinations). A self-contained lithium battery retains codes and has an emergency code dump feature. RF-5960 Master Code Programmer is required to insert codes.
Key Codes	Stores six of the available 1×10^{52} codes for loading.
Power	Internal lithium battery
Size	1.25 H x 1.93 W x 5.6 D inches (2.8 H x 4.2 W x 12.3 D cm)
Weight	0.5 lbs. (1.3 kg)

1.4 GENERAL DESCRIPTION OF MAJOR ASSEMBLIES

1.4.1 General

Table 1-7 lists the major assemblies of the receiver-transmitter. Figure 1-7 shows the locations of the assemblies in the receiver-transmitter.

Table 1-7. Assemblies and Reference Designators

Reference Designation	Assembly/Subassembly Name	Function
A1A1	Interface PWB Assembly	Provides the data interface between the receiver-transmitter and various types of external devices. If the A1A2 Encryption PWB Assembly (RF-5170 option) is installed, it connects directly to the A1A1 Interface PWB Assembly.
A1A2	Encryption PWB Assembly (RF-5170 option – RT-1694(P) configuration)	Provides the receiver-transmitter with the ability to encrypt and decrypt digital data. If the A3 LPC Vocoder Assembly (RF-5161-01 option) is also installed, the A1A2 PWB Assembly provides digital voice capabilities.
A3	Linear Predictive Coding (LPC) Vocoder Assembly (RF-5161-01 option)	The A3 LPC Vocoder Assembly can be factory configured to provide either Digital Voice (DV) or AVS. When configured for DV, this assembly provides secure voice communications using FEC with a similarly equipped receiver-transmitter. When used with the RF-5170 option, encrypted digital voice provides an extremely high level of security. When configured for AVS, this assembly provides secure voice by scrambling the transmitted audio signal.
A4	Signal Processor PWB Assembly	Provides control and coordination of all functional parts of the receiver-transmitter during operation and self-test. This assembly is divided into five functional areas: Main Controller, Digital IF/AGC, Modem, Frequency Hopping, and ALE. For more information on each of these functional areas, refer to Chapter 3, Functional Description.
A5	Receiver/Exciter Assembly	When receiving, this assembly converts HF and Very High Frequency (VHF) signals to an intermediate frequency for processing by the A4 Signal Processor PWB Assembly. When transmitting, this assembly converts the IF from the A4 Signal Processor PWB Assembly to a 100 milliwatt RF output signal.

Table 1-7. Assemblies and Reference Designators – Continued

Reference Designation	Assembly/Subassembly Name	Function
A6	Synthesizer Assembly	Consists of a reference generator assembly and a synthesizer assembly. The reference generator assembly contains a temperature-compensated crystal oscillator that provides a stable frequency reference for the radio. The synthesizer assembly generates the first Local Oscillator (first LO) signal that is used to convert a received or transmitted signal between 1.6000 and 59.9999 MHz to an IF frequency of 80.5 MHz.
A7	Power Supply Assembly	The A7 Power Supply Assembly is a switching power supply that generates the fixed voltages used throughout the receiver-transmitter.
A8	Power Amplifier/Battery Charger Assembly	Consists of a power amplifier/battery charger assembly and a harmonic filter assembly. The A8 Power Amplifier (PA)/Battery Charger Assembly amplifies the 100 milliwatt output signal from the A5 Receiver/Exciter Assembly up to 20 watts. This assembly also charges batteries attached to the receiver-transmitter. The harmonic filter assembly provides eight harmonic filters that reduce spurious emission levels.
A9	Antenna Coupler Assembly	Provides an L-C matching network that compensates for changing antenna tuning conditions. The result is a Voltage Standing Wave Ratio (VSWR) that is less than 2:1.
A10	Front Panel Assembly	Provides an interface to all connections and functions of the receiver-transmitter. This assembly also routes, buffers, and performs analog processing on all audio entering and exiting the radio. The A10 Front Panel Assembly installed in the RT-1694B(P)/U configuration also provides Night Vision Goggle (NVG) compatibility.
A11	Motherboard Assembly	Provides interconnection of all PWB assemblies for signal routing, control, and power distribution.
W1	PA – Coupler Coaxial Cable Assembly	Provides an RF path between the A8 PA/Battery Charger Assembly and A9 Antenna Coupler Assembly.
W2	PA – R/E Coaxial Cable Assembly	Provides an RF path between the A8 PA/Battery Charger Assembly and A5 Receiver/Exciter Assembly.

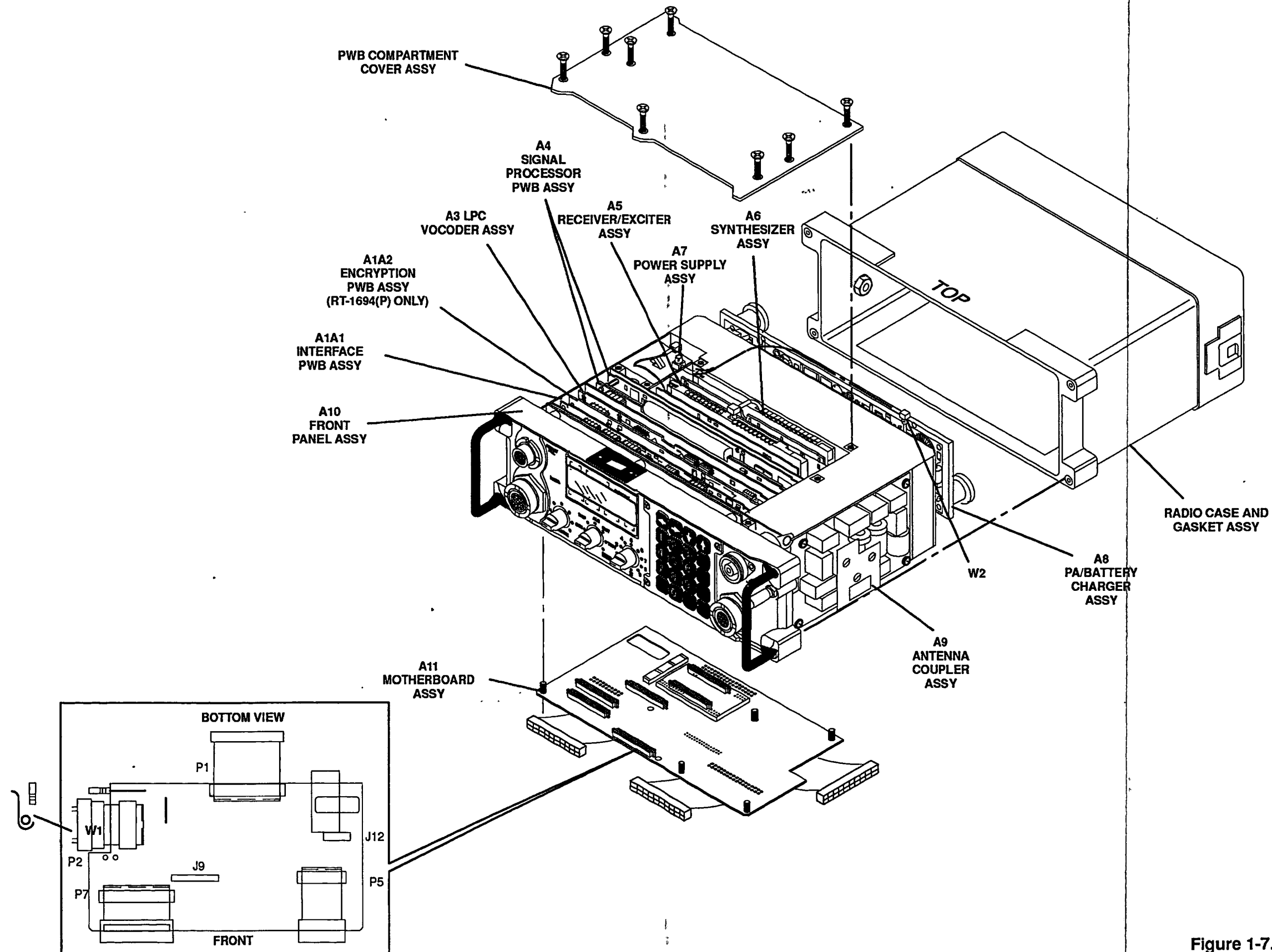

1694-004A

Figure 1-7. Locations of Assemblies

1.5 PARTS LISTS OF ITEMS SHIPPED WITH UNIT

There are no additional items shipped with the receiver-transmitter. Table 1-8 provides cage code information for the manufacturers of items listed in this manual.

Table 1-8. List of Manufacturers

Cage Code	Manufacturer Name and Address
14304	Harris Corporation RF Communications Division 1680 University Avenue Rochester, NY 14610-2842
19915	Diamond Tool and Horseshoe Company 4604/4704 Grand Avenue P. O. Box 6246 Duluth, MN 55806
20999	Minnesota Mining and Manufacturing Company Electrical Specialties Division 6801 River Place Blvd. Austin, TX 78726-9000
28480	Hewlett-Packard Company Corporate Headquarters 3000 Hanover Street Palo Alto, CA 94304-1112
55719	Snap On Tools Corporation 2801 80th Street Kenosha, WI 53141-1410
70998	Bird Electronics Corporation 30303 Aurora Road Solon, OH
80058	Joint Electronics Type Designation System Formerly Communication Electronics Subpanel of Standardization Panel Joint Communications Electronics Committee
81349	Military Specifications Promulgated by Military Departments/Agencies Under Authority of Defense Standardization Manual 4120 3-M
89536	Fluke Corporation 6920 Seaway Boulevard P.O. Box 9090 Everett, WA 98206-9090

Table 1-8. List of Manufacturers – Continued

Cage Code	Manufacturer Name and Address
96508	Cooper Industries, Inc. Cooper Tools Division Lufkin Road P. O. Box 728 Apex, NC 27502
96906	Military Standards Promulgated by Military Departments Under Authority of Defense Standardization Manual 4120 3-M

1.6 LIST OF ITEMS REQUIRED BUT NOT SUPPLIED

Table 1-9 lists the test equipment required for troubleshooting and repairing the receiver-transmitter. Table 1-10 lists the tools required for removing and replacing receiver-transmitter assemblies. A known-good radio system, called a Hot Test Bed, is also required when making Level III repairs. Table 1-11 lists the Hot Test Bed items. For Hot Test Bed interconnect information, refer to Chapter 8, Figure 8-2.

Table 1-9. Test Equipment Required, But Not Supplied

Description	Part Number	Cage Code
Signal Generator, RF	8657A	28480
Breakout Box	1008-1100	14304
Audio Analyzer	8903B	28480
Attenuator, 200 Watt	77B6-30	70998
Power Meter, RF	437B	28480
Power Sensor	8482B	28480
Frequency Counter	5385A	28480
Digital Multimeter	AN/PSM-45A	89536

Table 1-10. Master Required Tools and Materials List

Description	Part Number	Cage Code
Screwdriver, No. 0 Cross-Tip	X-100	96508
Screwdriver, No.1 Cross-Tip	X-101	96508
Screwdriver, No. 2 Cross-Tip	X-102	96508
Hex Screwdriver Bit, 5/32 Inch	99-25	96508
Jewelers Pliers, 4 Inch	LN54	19915
Socket Wrench, 3/16 Inch	99-6	96508
Screwdriver Handle	99-1	96508
Ground Strap	3M-2064	20999
Electrostatic Discharge (ESD) Mat	1872	20999

Table 1-11. Hot Test Bed Items

Description	Part Number	Cage Code
RT-1694(P) Receiver-Transmitter, or RT-1694B(P)/U Receiver-Transmitter	10372-1000-01 10530-1000-01	14304
Power Supply	6268B	28480
Handset (H-250/U)	10075-1344-01	14304
DC Power Cable Assembly	10394-9010	14304
Adapter, N-type (m) to BNC (f)	M55339/20-00201	81349
Adapter, N-type (f) to BNC (f)	M55339/01-00001	81349
Cable Assembly, RF, BNC (m)	10503A	28480
Cable Assembly, Auxiliary	10372-9850	14304
Battery Eliminator	10372-9330	14304

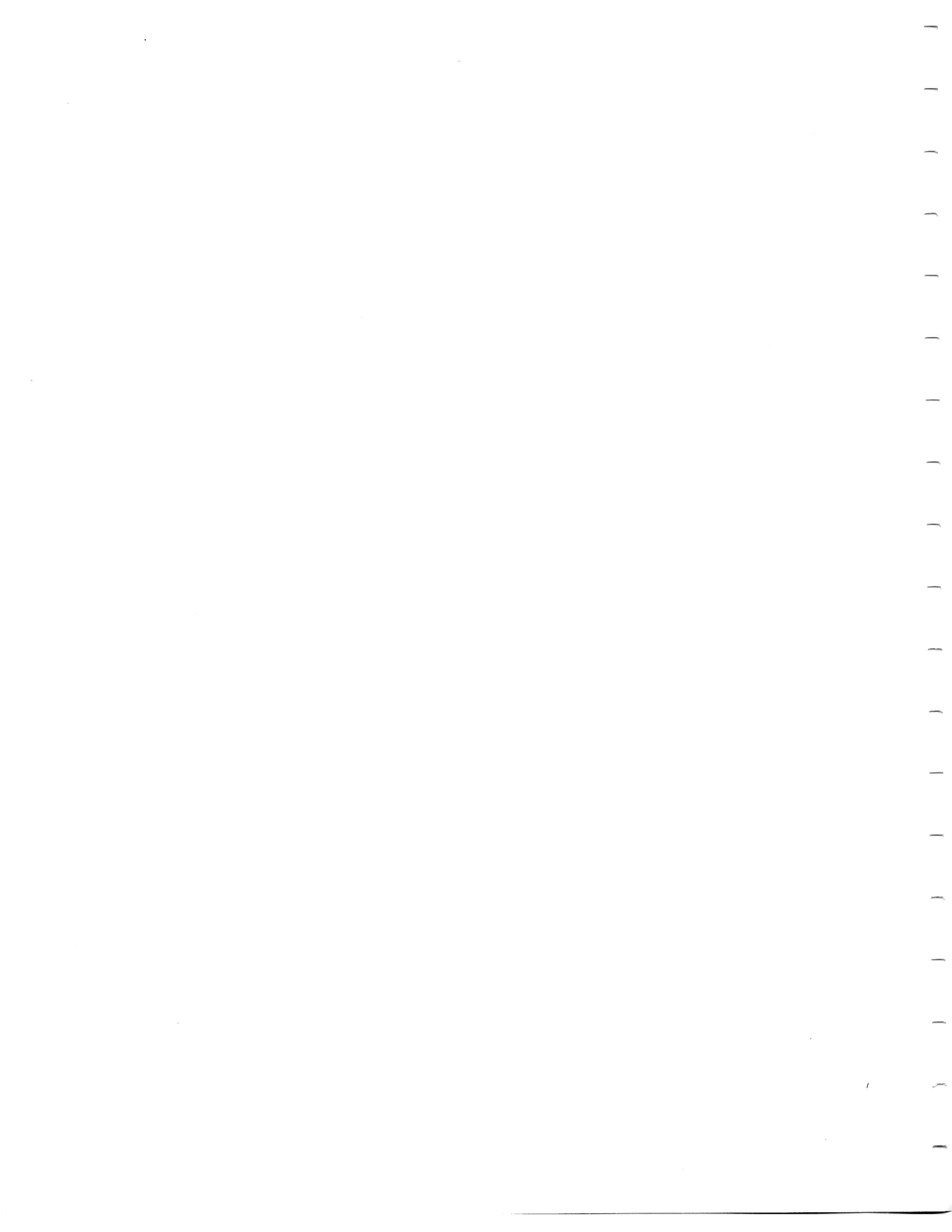

CHAPTER 2

OPERATION

2.1 INTRODUCTION

2.1.1 General

This chapter contains information necessary for operation of the receiver-transmitter at this maintenance level. This information consists of operator controls and indicators, and operating instructions.

2.2 OPERATOR CONTROLS AND INDICATORS

2.2.1 General

Figure 2-1 shows the front panel of the receiver-transmitter.

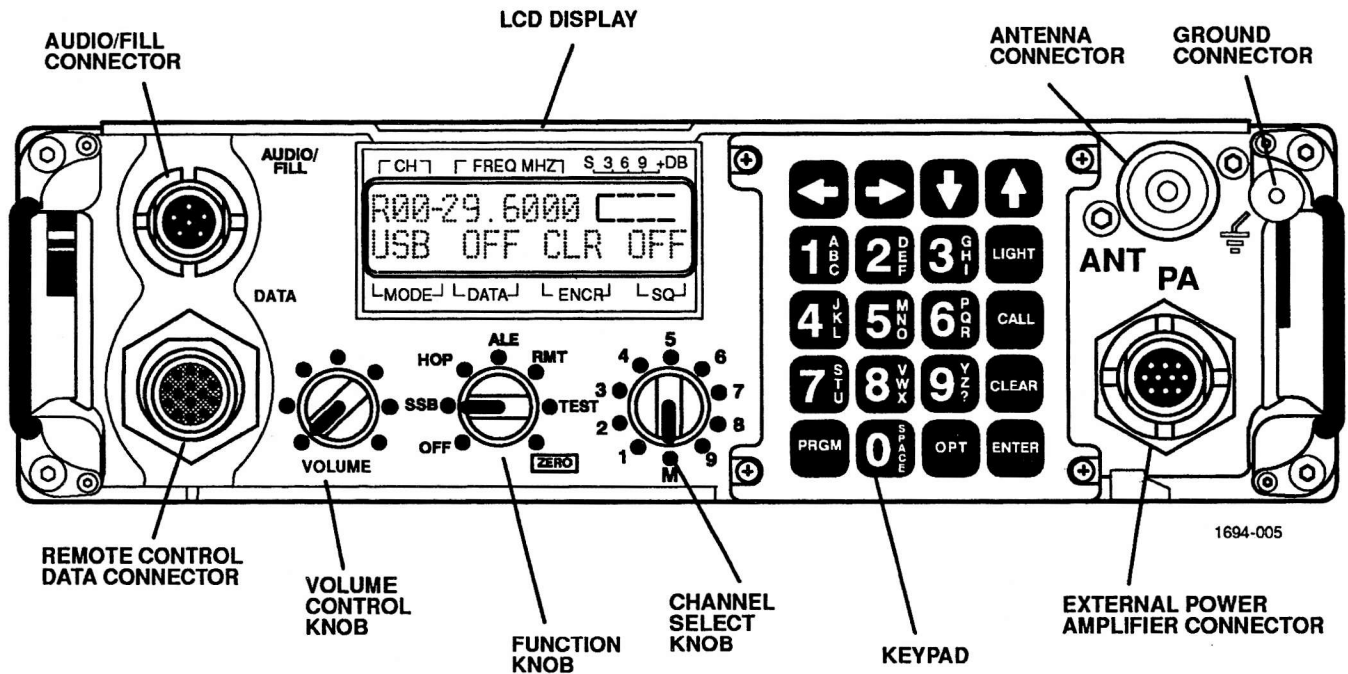

Figure 2-1. Receiver-Transmitter Front Panel

2.3 CONNECTORS

Figure 2-1 shows the front panel of the receiver-transmitter. Five connectors are located on the front panel:

- The AUDIO/FILL connector is where a handset or headset is connected to the receiver-transmitter. This connector is also where a fill gun is attached for loading encryption keys into the radio. Refer to the RF-5200 FALCON™ Series Tactical Communications Manpack System Manual (10515-0006-4200) for further information on loading encryption keys.
- The DATA connector is where a remote control device is connected to the receiver-transmitter.
- A whip antenna or an external power amplifier is connected to the receiver-transmitter via the ANT (antenna) connector.
- An external power amplifier's control line is connected to the Power Amplifier (PA) connector on the receiver-transmitter.
- The receiver-transmitter is grounded via the ground connector.

The only connectors on the rear panel of the receiver-transmitter are the battery pack connectors (J5 and J6).

2.4 OPERATING PROCEDURES

2.4.1 Initial Settings and Power Up

Initial settings and power up consists of turning on the unit and executing the Built-In Test (BIT). Refer to Table 2-2 for the initial settings and power-up procedure.

2.4.1.1 BIT

BIT is executed from the front panel of the receiver-transmitter or from a terminal connected to the DATA connector. The self-test function of the receiver-transmitter automatically tests the receiver-transmitter. If an external power amplifier and antenna coupler are connected to the receiver-transmitter, these units are also tested by BIT.

BIT is a built-in diagnostic routine in the receiver-transmitter. The test verifies operation of receiver-transmitter internal assemblies (and the external power amplifier and antenna coupler, if attached). If a problem is located, a code is displayed on the front panel identifying the fault. Refer to Table 2-1 for an index of module codes and assemblies. A fault code is also displayed. The fault code helps identify how the Shop Replaceable Unit (SRU) failed. See Figure 2-2. Refer to Table 5-4 for a complete list of receiver-transmitter fault codes. Fault codes pertaining to the RF-5045 Pre/Postselector (A28) or external power amplifiers (A30) can be found in the respective Level III Maintenance Manual.

Table 2-1. Receiver-Transmitter Module Code/Assembly Index

Module Code	Assembly Identified
A01*	Interface or Encryption Printed Wiring Board (PWB) Assemblies*
A03	Linear Predictive Coding (LPC) Vocoder Assembly
A04	Signal Processor PWB Assembly
A05	Receiver/Exciter Assembly
A06	Synthesizer Assembly
A08	PA/Battery Charger Assembly
A09	Antenna Coupler Assembly
A10	Front Panel Assembly

*NOTE: Module Code A01 can identify either the A1A1 Interface PWB Assembly or A1A2 Encryption PWB Assembly (if installed). Refer to Chapter 5, Troubleshooting, for information on how to determine which assembly is causing the A01 fault.

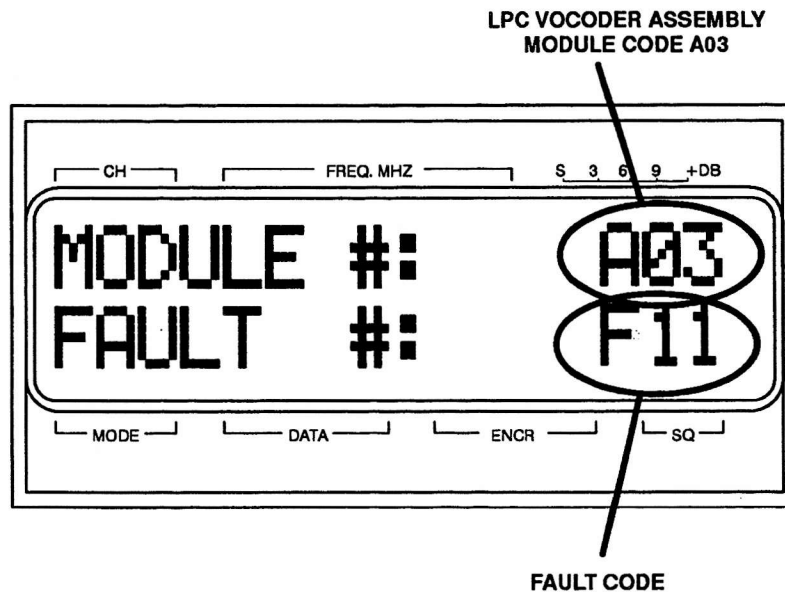

1694-006

Figure 2-2. Sample Fault Code Display

2.4.1.1.1 Starting BIT

Table 2-2 provides instructions to execute BIT.

Table 2-2. Initial Settings and Executing BIT

Step	Control	Action	Observe
1	FUNCTION knob on receiver-transmitter	Turn clockwise from OFF position to Single Sideband (SSB) position.	The receiver-transmitter displays the same display from when it was last used in SSB mode.
2	FUNCTION knob on receiver-transmitter	Turn clockwise from SSB position to TEST position.	The receiver-transmitter displays the following screen: * INITIALIZING * * * * * WAIT * * * * followed by: TEST VERSION VSWR BATTERY
3	← or → keys	Press and release repeatedly to select TEST (if necessary).	The receiver-transmitter displays the following screen: TEST VERSION VSWR BATTERY with TEST flashing.
4	ENTER key on receiver-transmitter	Press and release.	The receiver-transmitter displays the following screen: ** SELF TEST ** * IN PROGRESS * If no errors occur during BIT, the receiver-transmitter displays the following screen: SELF TEST DONE ** NO ERRORS ** If a fault is detected during execution of BIT, a fault code display will be shown. See Figure 2-2. If this occurs, note the fault code and proceed to Chapter 5, Paragraph 5.2.4.
5	FUNCTION knob on receiver-transmitter	Turn counterclockwise from TEST position to SSB position.	The receiver-transmitter displays the same display from when it was last used in SSB mode, and is now ready for normal operation.

2.4.1.1.2 Run-Time Faults

Run-time faults may occur during normal operation of the RF-5200 FALCON™ Series Tactical Communications Manpack System. In these cases, a fault message will be displayed on the receiver-transmitter front panel display. When this occurs, run BIT according to the procedure in Table 2-3. For more information on run-time faults, refer to Chapter 5, Troubleshooting.

Table 2-3. Executing BIT After Run-Time Fault

Step	Control	Action	Observe
1	FUNCTION knob on receiver-transmitter	Turn clockwise from SSB position to TEST position.	The receiver-transmitter displays the following screen: * INITIALIZING * * * * * WAIT * * * * followed by: TEST VERSION VSWR BATTERY
2	← or → keys	Press and release repeatedly to select TEST (if necessary).	The receiver-transmitter displays the following screen: TEST VERSION VSWR BATTERY with TEST flashing.
3	ENTER key on receiver-transmitter	Press and release.	The receiver-transmitter displays the following screen: ** SELF TEST ** * IN PROGRESS *
4			If no errors occur during BIT, the receiver-transmitter displays the following screen: SELF TEST DONE ** NO ERRORS **
5			If BIT identifies a fault, note the fault code and proceed to Chapter 5, Paragraph 5.2.4. If no fault code is identified, proceed to Chapter 5, Paragraph 5.2.3.

2.4.2 Normal and Emergency Shutdown

Special emergency shutdown procedures are not required. Table 2-4 gives the procedure used for normal shutdown of the receiver-transmitter and external power amplifier, if one is attached.

Table 2-4. Receiver-Transmitter/Power Amplifier Shutdown Procedure

Step	Control	Action	Observe
1	FUNCTION knob on receiver-transmitter	Turn counterclockwise to OFF position.	All front panel lamps and displays go out. Settings will be retained in memory while the unit is off.

CHAPTER 3

FUNCTIONAL DESCRIPTION

3.1 INTRODUCTION

3.1.1 General

This chapter covers the functional description of the circuitry in the receiver-transmitter. Paragraph 3.2 contains the overall functional description. Paragraph 3.3 provides the major level functional description which covers the major circuits on the Shop Replaceable Units (SRUs). Refer to Chapter 5 for Built-In Test (BIT) and troubleshooting information.

3.2 OVERALL FUNCTIONAL DESCRIPTION

3.2.1 General

The following paragraphs provide an overall description of how the receiver-transmitter functions.

3.2.2 Purpose of the Receiver-Transmitter

The receiver-transmitter operates from 1.6 MHz to 59.9999 MHz. All functions are controlled from the front panel (or remote control). A 32-character, alphanumeric display provides system status information and reflects data entry to simplify unit operation and programming. Optional modules are installed in the chassis.

3.2.3 Functional Level Descriptions

A number of receiver-transmitter functional level descriptions are described in the following paragraphs:

- Paragraph 3.2.3.1 – Analog Clear Voice Functional Level Descriptions
- Paragraph 3.2.3.2 – Digital Voice (Unencrypted) Functional Level Descriptions
- Paragraph 3.2.3.3 – Analog Voice Security (AVS) Functional Level Descriptions
- Paragraph 3.2.3.4 – Encrypted Digital Data Functional Level Descriptions
- Paragraph 3.2.3.5 – Encrypted Digital Voice Functional Level Descriptions
- Paragraph 3.2.3.6 – Automatic Link Establishment (ALE) Functional Level Descriptions
- Paragraph 3.2.3.7 – Frequency Hopping Functional Level Descriptions
- Paragraph 3.2.3.8 – Frequency Modulation (FM) Functional Level Descriptions

For a discussion of Radio Frequency (RF)/Intermediate Frequency (IF)/audio/digital signal paths and power distribution paths, refer to Paragraph 3.3.

3.2.3.1 Analog Clear Voice Functional Level Descriptions

Paragraph 3.2.3.1.1 provides a functional level description of the receiver-transmitter when transmitting analog clear voice. Paragraph 3.2.3.1.2 provides a functional level description of the receiver-transmitter when receiving analog clear voice. See Figure 3-1.

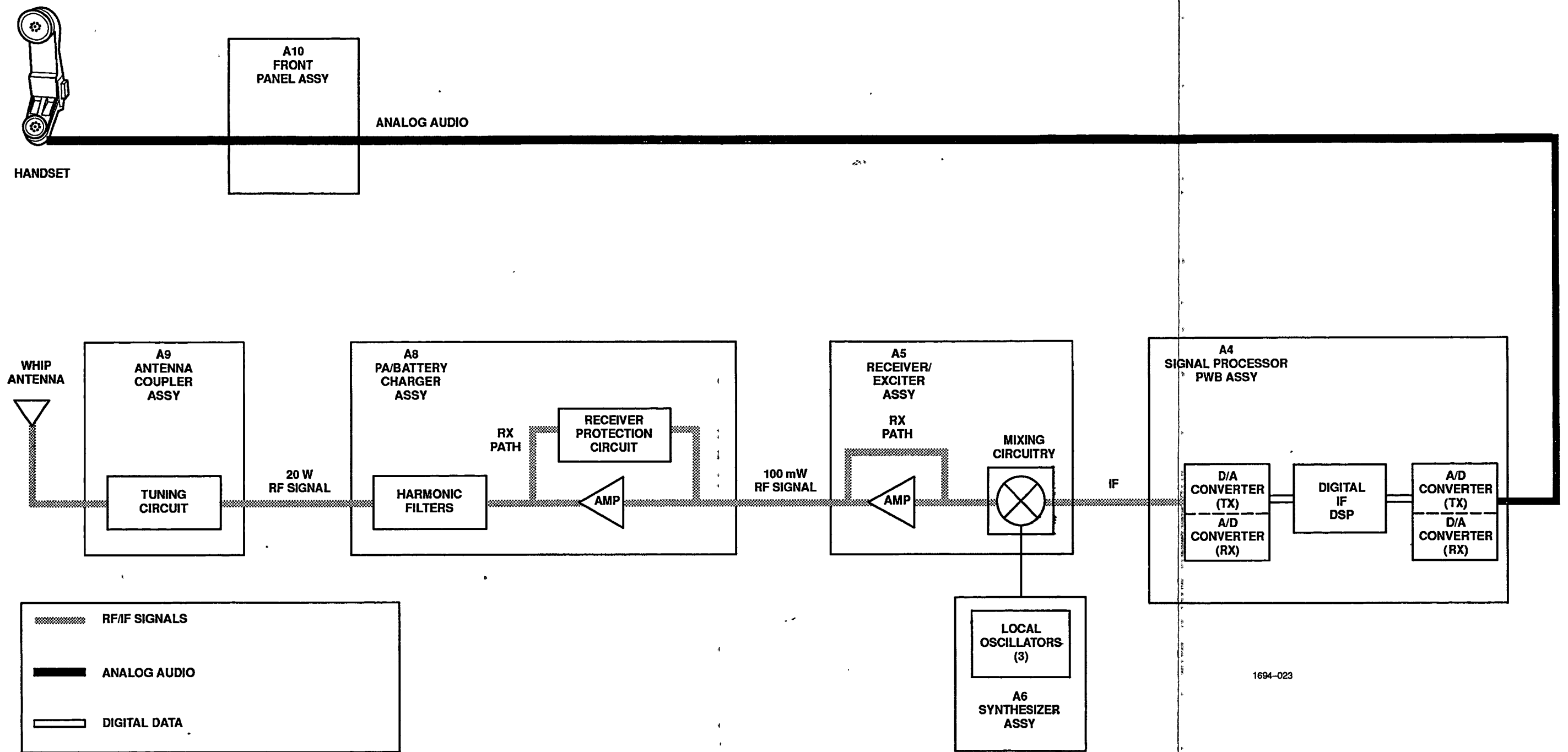

1694-023

Figure 3-1. Receiver-Transmitter Analog Clear Voice Functional Block Diagram

3.2.3.1.1 Transmitting Analog Clear Voice

Audio enters the radio at the handset when it is keyed and spoken into. The audio signal is routed from A10 Front Panel Assembly to the Analog-to-Digital (A/D) converter on A4 Signal Processor Printed Wiring Board (PWB) Assembly for digitizing. The digitized audio is passed to the IF Digital Signal Processor (DSP), which generates the digital representation of an IF. This signal then passes through a Digital-to-Analog (D/A) converter, where the digitized IF is converted into an analog signal. This signal is passed to the A5 Receiver/Exciter Assembly for conversion to a RF signal.

Mixing circuitry on the A5 Receiver/Exciter Assembly mixes the IF signal with signals from the local oscillators on the A6 Synthesizer Assembly. The resulting RF signal is in the frequency range of 1.6 MHz to 59.9999 MHz. This RF signal is amplified to approximately 100 mW before being output to the A8 Power Amplifier (PA)/Battery Charger Assembly.

The A8 PA/Battery Charger Assembly amplifies the 100 mW RF signal to 20 watts. The 20-watt signal then passes through one of eight harmonic filters to reduce the level of unwanted harmonics. The 20-watt RF signal then passes through a tuning circuit on the A9 Antenna Coupler Assembly before being transmitted through the whip antenna.

3.2.3.1.2 Receiving Analog Clear Voice

RF signals in the frequency range of 1.6 MHz to 59.9999 MHz are received by the receiver-transmitter at the whip antenna. These signals pass through the tuning circuit on the A9 Antenna Coupler Assembly and one of the harmonic filters on the A8 PA/Battery Charger Assembly. The RF signal then follows the Receive (RX) path through the receiver protection circuit on the A8 PA/Battery Charger Assembly. These signals are then routed to the A5 Receiver/Exciter Assembly. The RF signal is mixed with signals from the local oscillators on the A6 Synthesizer Assembly. The result is an IF signal.

The IF signal is then converted to a digital representation of the IF signal by the A/D converter on the A4 Signal Processor PWB Assembly. The A/D converter passes this signal to the digital IF DSP, which removes the IF components of the signal. The digital signal is then processed by the D/A converter, which creates an analog audio signal. The analog audio then passes through the A10 Front Panel Assembly, where it is routed to the handset.

3.2.3.2 Unencrypted Digital Voice Functional Level Descriptions

Paragraph 3.2.3.2.1 provides a functional level description of the receiver-transmitter when transmitting digital voice. Paragraph 3.2.3.2.2 provides a functional level description of the receiver-transmitter when receiving digital voice. See Figure 3-2.

3.2.3.2.1 Transmitting Unencrypted Digital Voice

Transmit audio from the handset passes through the A10 Front Panel Assembly to the A/D converter on the A3 Linear Predictive Coding (LPC) Vocoder Assembly. The digital data is passed to the LPC processor, which passes the data to the modem processor on the A4 Signal Processor PWB Assembly. The modem processor creates a digital representation of a 39-tone waveform. This digital waveform is passed to the digital IF DSP, which generates a digital representation of a 6 kHz IF. This signal then passes through a D/A converter, where the digitized IF is converted into an analog signal. This signal is passed to the A5 Receiver/Exciter Assembly for conversion to an RF signal.

Mixing circuitry on the A5 Receiver/Exciter Assembly mixes the IF signal with signals from the local oscillators on the A6 Synthesizer Assembly. The resulting RF signal is in the frequency range of 1.6 MHz to 59.9999 MHz. This RF signal is amplified to approximately 100 mW before being output to the A8 Power Amplifier/Battery Charger Assembly.

The A8 PA/Battery Charger Assembly amplifies the 100 mW RF signal to 20 watts. The 20-watt signal then passes through one of eight harmonic filters to reduce the level of unwanted harmonics. The 20-watt RF signal then passes through a tuning circuit on the A9 Antenna Coupler Assembly before being transmitted through the whip antenna.

3.2.3.2.2 Receiving Unencrypted Digital Voice

RF signals in the frequency range of 1.6 MHz to 59.9999 MHz are received by the receiver-transmitter at the whip antenna. These signals pass through the tuning circuit on the A9 Antenna Coupler Assembly and one of the harmonic filters on the A8 PA/Battery Charger Assembly. The RF signal then follows the RX path through the receiver protection circuit on A8 PA/Battery Charger Assembly. These signals are then routed to the A5 Receiver/Exciter Assembly. The RF signal is mixed with signals from the local oscillators on the A6 Synthesizer Assembly. The result is an IF signal.

The IF signal is then converted to a digital representation of the IF signal by the A/D converter on the A4 Signal Processor PWB Assembly. The A/D converter passes this signal to the digital IF DSP, which removes the IF components of the signal. The digital signal is then processed by the modem processor, which demodulates the 39-tone signal. The resulting digital signal passes to the LPC processor on the A3 LPC Vocoder Assembly. The signal then passes through the D/A converter on the A3 LPC Vocoder Assembly, resulting in an analog audio signal. The analog audio then passes through the A10 Front Panel Assembly, where it is routed to the handset.

3.2.3.3 Analog Voice Security (AVS) Functional Level Descriptions

Paragraph 3.2.3.3.1 provides a functional level description of the receiver-transmitter when transmitting with AVS enabled. Paragraph 3.2.3.3.2 provides a functional level description of the receiver-transmitter when receiving with AVS enabled. See Figure 3-3.

3.2.3.3.1 Transmitting with AVS Enabled

Audio enters the radio at the handset when it is keyed and spoken into. The audio signal is routed from the A10 Front Panel Assembly to the A3 LPC Vocoder Assembly, where the analog audio signal is converted to encrypted audio by the LPC processor. This encrypted audio signal is transferred to the A/D converter on the A4 Signal Processor PWB Assembly for digitizing. The digital data is passed to the digital IF DSP, which generates a digital representation of a 6 kHz IF. This signal then passes through a D/A converter, where the digitized IF is converted into an analog signal. This signal is passed to the A5 Receiver/Exciter Assembly for conversion to an RF signal.

Mixing circuitry on the A5 Receiver/Exciter Assembly mixes the IF signal with signals from the local oscillators on the A6 Synthesizer Assembly. The resulting RF signal is in the frequency range of 1.6 MHz to 59.9999 MHz. This RF signal is amplified to approximately 100 mW before being output to the A8 PA/ Battery Charger Assembly.

The A8 PA/Battery Charger Assembly amplifies the 100 mW RF signal to 20 watts. The 20-watt signal then passes through one of eight harmonic filters to reduce the level of unwanted harmonics. The 20-watt RF signal then passes through a tuning circuit on the A9 Antenna Coupler Assembly before being transmitted through the whip antenna.

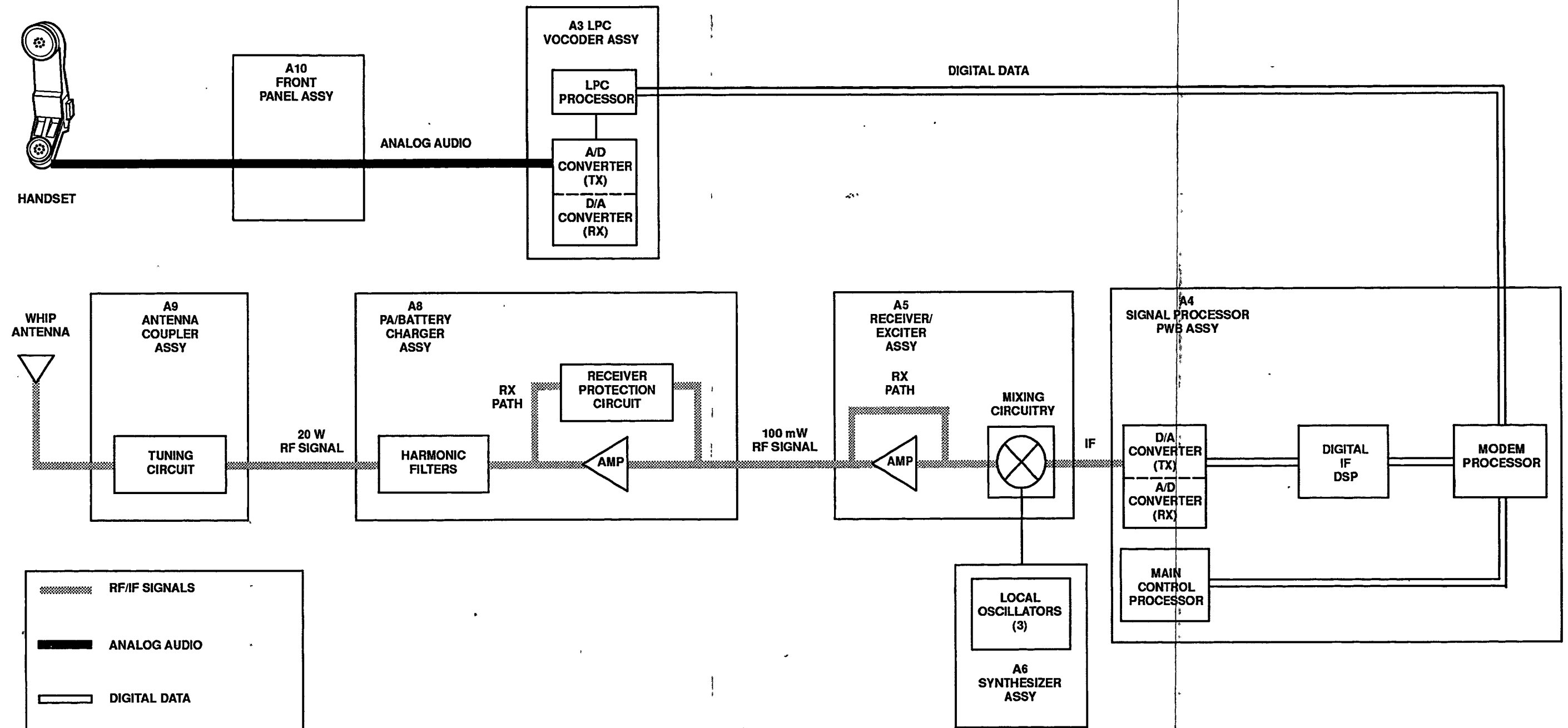

1694-026

Figure 3-2. Receiver-Transmitter Unencrypted Digital Voice Functional Block Diagram

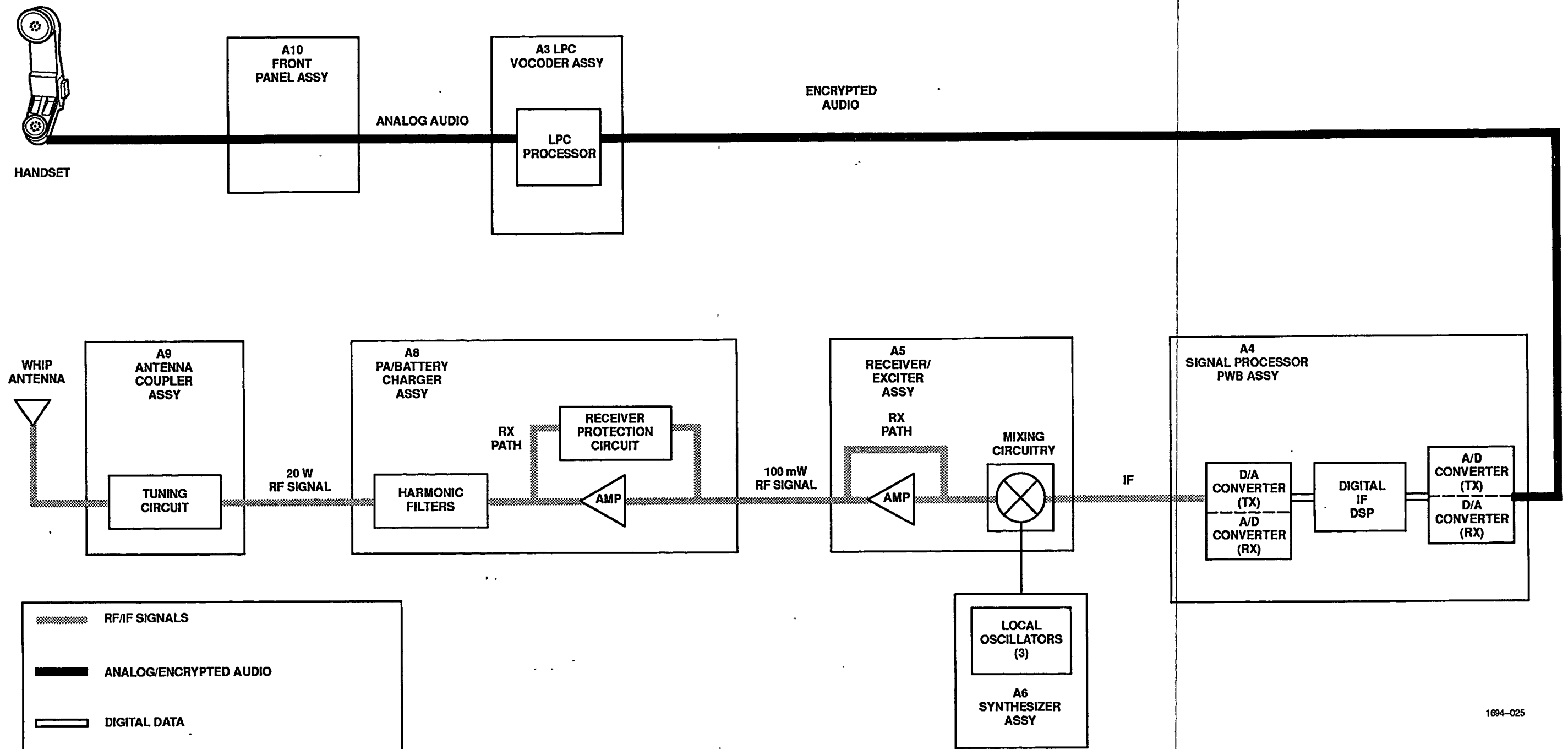

1694-025

Figure 3-3. Receiver-Transmitter AVS Simplified Functional Block Diagram

3.2.3.3.2 Receiving with AVS Enabled

RF signals in the frequency range of 1.6 MHz to 59.9999 MHz are received by the receiver-transmitter at the whip antenna. These signals pass through the tuning circuit on the A9 Antenna Coupler Assembly and one of the harmonic filters on the A8 PA/Battery Charger Assembly. The RF signal then follows the RX path through the receiver protection circuitry on the A8 PA/Battery Charger Assembly. These signals are then routed to the A5 Receiver/Exciter Assembly. The RF signal is mixed with signals from the local oscillators on the A6 Synthesizer Assembly. The result is an IF signal.

The IF signal is then converted to a digital representation of the IF signal by the A/D converter on the A4 Signal Processor PWB Assembly. The A/D converter passes this signal to the digital IF DSP, which removes the IF components of the signal. The digital signal is then processed by the D/A converter, which creates an encrypted audio signal. The encrypted audio signal is then transferred to the A3 LPC Vocoder Assembly, where the audio signal is decrypted. The analog audio then passes through the A10 Front Panel Assembly, where it is routed to the handset.

3.2.3.4 Encrypted Digital Data Functional Level Descriptions

Paragraph 3.2.3.4.1 provides a functional level description of the receiver-transmitter when transmitting encrypted digital data. Paragraph 3.2.3.4.2 provides a functional level description of the receiver-transmitter when receiving encrypted digital data. See Figure 3-4.

3.2.3.4.1 Transmitting Encrypted Digital Data

Digital data from an external computer or terminal enters the radio at the A10 Front Panel Assembly. The digital data is routed from the A10 Front Panel Assembly through the A1A1 Interface PWB Assembly to the A1A2 Encryption PWB Assembly, where it is encrypted by the encryption processor. Once encrypted, the digital encrypted data passes back through the A1A1 Interface PWB Assembly before reaching the modem processor on the A4 Signal Processor PWB Assembly, where the signal is modulated. The digital encrypted data is then passed to the digital IF DSP, which generates a digital representation of a 6 kHz IF. This signal then passes through a D/A converter, where the digitized IF is converted into an analog signal. This signal is passed to the A5 Receiver/Exciter Assembly for conversion to an RF signal.

Mixing circuitry on the A5 Receiver/Exciter Assembly mixes the IF signal with signals from the local oscillators on the A6 Synthesizer Assembly. The resulting RF signal is in the frequency range of 1.6 MHz to 59.9999 MHz. This RF signal is amplified to approximately 100 mW before being output to the A8 PA/Battery Charger Assembly.

The A8 PA/Battery Charger Assembly amplifies the 100 mW RF signal to 20 watts. The 20-watt signal then passes through one of eight harmonic filters to reduce the level of unwanted harmonics. The 20-watt RF signal then passes through a tuning circuit on the A9 Antenna Coupler Assembly before being transmitted through the whip antenna.

3.2.3.4.2 Receiving Encrypted Digital Data

RF signals in the frequency range of 1.6 MHz to 59.9999 MHz are received by the receiver-transmitter at the whip antenna. These signals pass through the tuning circuit on the A9 Antenna Coupler Assembly and one of the harmonic filters on the A8 PA/Battery Charger Assembly. The RF signal then follows the RX path through the receiver protection circuitry on the A8 PA/Battery Charger Assembly. These signals are then routed to the A5 Receiver/Exciter Assembly. The RF signal is mixed with signals from the local oscillators on the A6 Synthesizer Assembly. The result is an IF signal.

The IF signal is then converted to a digital representation of the IF signal by the A/D converter on the A4 Signal Processor PWB Assembly. The A/D converter passes this signal to the digital IF DSP, which removes the IF components of the signal. The digital signal is then processed by the modem processor, creating digital encrypted

data. This data is then transferred to through the A1A1 Interface PWB Assembly to the A1A2 Encryption PWB Assembly, where the data is decrypted. This digital data is then sent back through the A1A1 Interface PWB Assembly to the A10 Front Panel Assembly, where it is routed to the external computer or terminal.

3.2.3.5 Encrypted Digital Voice Functional Level Descriptions

Paragraph 3.2.3.5.1 provides a functional level description of the receiver-transmitter when transmitting encrypted digitized voice. Paragraph 3.2.3.5.2 provides a functional level description of the receiver-transmitter when receiving encrypted digitized voice. See Figure 3-5.

3.2.3.5.1 Transmitting Encrypted Digital Voice

Audio enters the radio at the handset when it is keyed and spoken into. The audio signal is routed from the A10 Front Panel Assembly to the A3 LPC Vocoder Assembly, where the analog audio signal is converted to digital data by an A/D converter. This digital data passes through the A1A1 Interface PWB Assembly to the A1A2 Encryption PWB Assembly, where it is encrypted by the encryption processor. Once encrypted, the digital encrypted data passes back through the A1A1 Interface PWB Assembly before reaching the modem processor on the A4 Signal Processor PWB Assembly, where the signal is modulated. The digital encrypted data is then passed to the digital IF DSP, which generates a digital representation of a 6 kHz IF. This signal then passes through a D/A converter, where the digitized IF is converted into an analog signal. This signal is passed to the A5 Receiver/Exciter Assembly for conversion to an RF signal.

Mixing circuitry on the A5 Receiver/Exciter Assembly mixes the IF signal with signals from the local oscillators on the A6 Synthesizer Assembly. The resulting RF signal is in the frequency range of 1.6 MHz to 59.9999 MHz. This RF signal is amplified to approximately 100 mW before being output to the A8 PA/Battery Charger Assembly.

The A8 PA/Battery Charger Assembly amplifies the 100 mW RF signal to 20 watts. The 20-watt signal then passes through one of eight harmonic filters to reduce the level of unwanted harmonics. The 20-watt RF signal then passes through a tuning circuit on the A9 Antenna Coupler Assembly before being transmitted through the whip antenna.

3.2.3.5.2 Receiving Encrypted Digital Voice

Radio frequency signals in the frequency range of 1.6 MHz to 59.9999 MHz are received by the receiver-transmitter at the whip antenna. These signals pass through the tuning circuit on the A9 Antenna Coupler Assembly and one of the harmonic filters on the A8 PA/Battery Charger Assembly. The RF signal then follows the receive RX path through the receiver protection circuitry on the A8 PA/Battery Charger Assembly. These signals are then routed to the A5 Receiver/Exciter Assembly. The RF signal is mixed with signals from the local oscillators on the A6 Synthesizer Assembly. The result is an IF signal.

The IF signal is then converted to a digital representation of the IF signal by the A/D converter on the A4 Signal Processor PWB Assembly. The A/D converter passes this signal to the digital IF DSP, which removes the IF components of the signal. The digital signal is then processed by the modem processor, creating digital encrypted data. This data is then transferred through the A1A1 Interface PWB Assembly to the A1A2 Encryption PWB Assembly, where the data is decrypted. This digital data then passes through the A1A1 Interface PWB Assembly to the A3 LPC Vocoder Assembly, where the D/A converter generates an analog audio signal. The analog audio then passes through the A10 Front Panel Assembly, where it is routed to the handset.

3.2.3.6 Automatic Link Establishment (ALE) Functional Level Descriptions

Paragraph 3.2.3.6.1 provides a functional-level description of the receiver-transmitter when transmitting an ALE call. Paragraph 3.2.3.6.2 provides a functional-level description of the receiver-transmitter when receiving an ALE call. See Figure 3-6.

3.2.3.6.1 Establishing an ALE Link (Transmit Side)

The operator presses the CALL button on the receiver-transmitter front panel, generating a command that is received by the ALE processor. The ALE processor commands the main control processor to configure the receiver-transmitter to the correct channel transmit frequency. Once this has been accomplished, the ALE processor sends digital data to the digital IF DSP, which generates a digital representation of a 6 kHz IF. This signal then passes through a D/A converter, where the digitized IF is converted into an analog signal. This signal is passed to the A5 Receiver/Exciter Assembly for conversion to an RF signal.

Mixing circuitry on the A5 Receiver/Exciter Assembly mixes the IF signal with signals from the local oscillators on the A6 Synthesizer Assembly. The resulting RF signal is in the frequency range of 1.6 MHz to 59.9999 MHz. This RF signal is amplified to approximately 100 mW before being output to the A8 PA/Battery Charger Assembly.

The A8 PA/Battery Charger Assembly amplifies the 100 mW RF signal to 20 watts. The 20-watt signal then passes through one of eight harmonic filters to reduce the level of unwanted harmonics. The 20-watt RF signal then passes through a tuning circuit on the A9 Antenna Coupler Assembly before being transmitted through the whip antenna.

3.2.3.6.2 Establishing an ALE Link (Receive Side)

The radio is scanning its channel set. The ALE processor instructs the main control processor to configure the receiver-transmitter to a particular channel.

Once this has been accomplished, RF signals at that channel's frequency (1.6 MHz to 59.9999 MHz) are received by the receiver-transmitter at the whip antenna. These signals pass through the tuning circuit on the A9 Antenna Coupler Assembly and one of the harmonic filters on the A8 PA/Battery Charger Assembly. The RF signal then follows the RX path through the receiver protection circuitry on the A8 PA/Battery Charger Assembly. These signals are then routed to the A5 Receiver/Exciter Assembly. The RF signal is mixed with signals from the local oscillators on the A6 Synthesizer Assembly. The result is an IF signal.

The IF signal is then converted to a digital representation of the IF signal by the A/D converter on the A4 Signal Processor PWB Assembly. The A/D converter passes this signal to the digital IF DSP which removes the IF components of the signal. The digital signal is then passed to the ALE processor which checks to see if valid ALE data is present. If valid ALE data is not present, the ALE processor commands the main control processor to configure the receiver-transmitter to the next channel. If valid ALE data is present, the ALE processor commands the receiver-transmitter to transmit a link response, which is similar to the transmit process described in Paragraph 3.2.3.6.1.

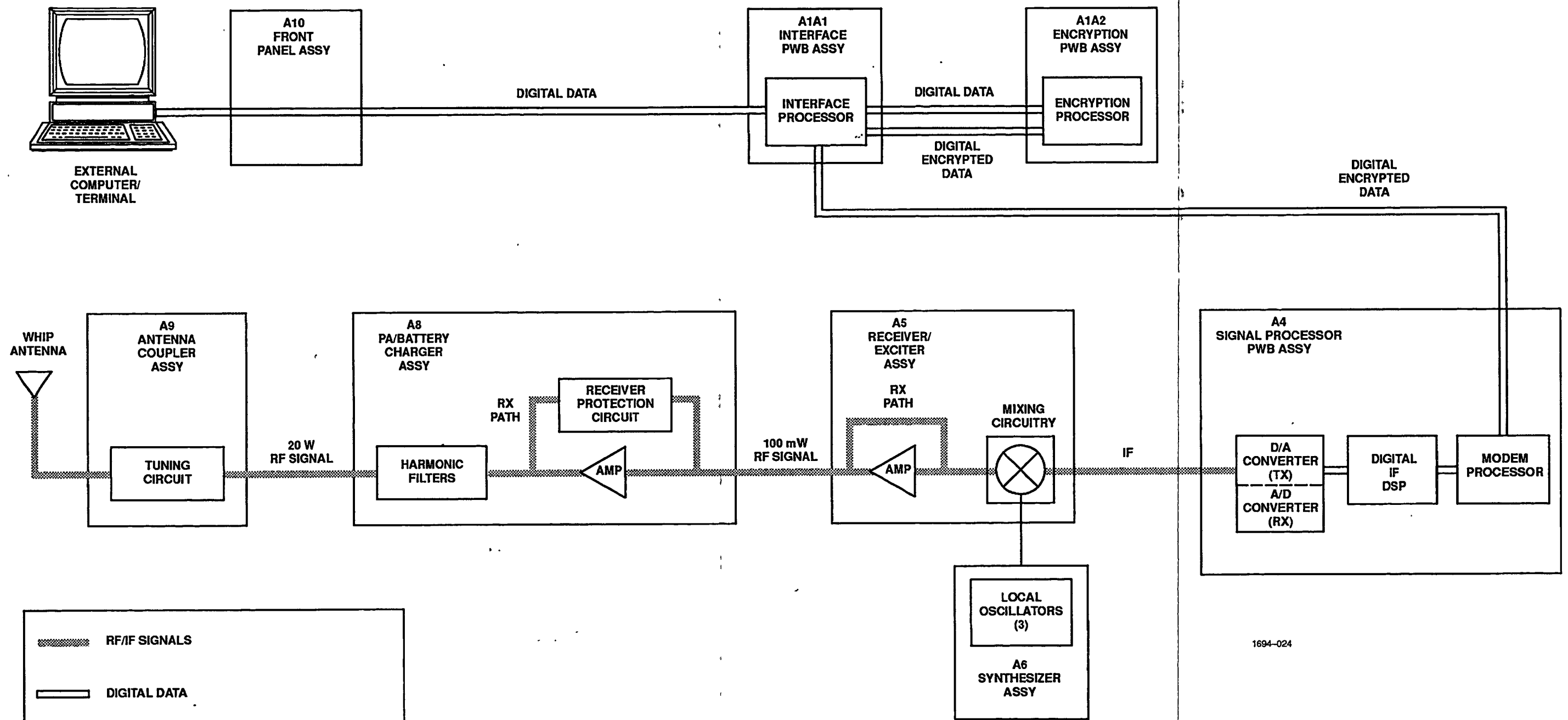

1694-024

Figure 3-4. Receiver-Transmitter Encrypted Digital Data Simplified Functional Block Diagram

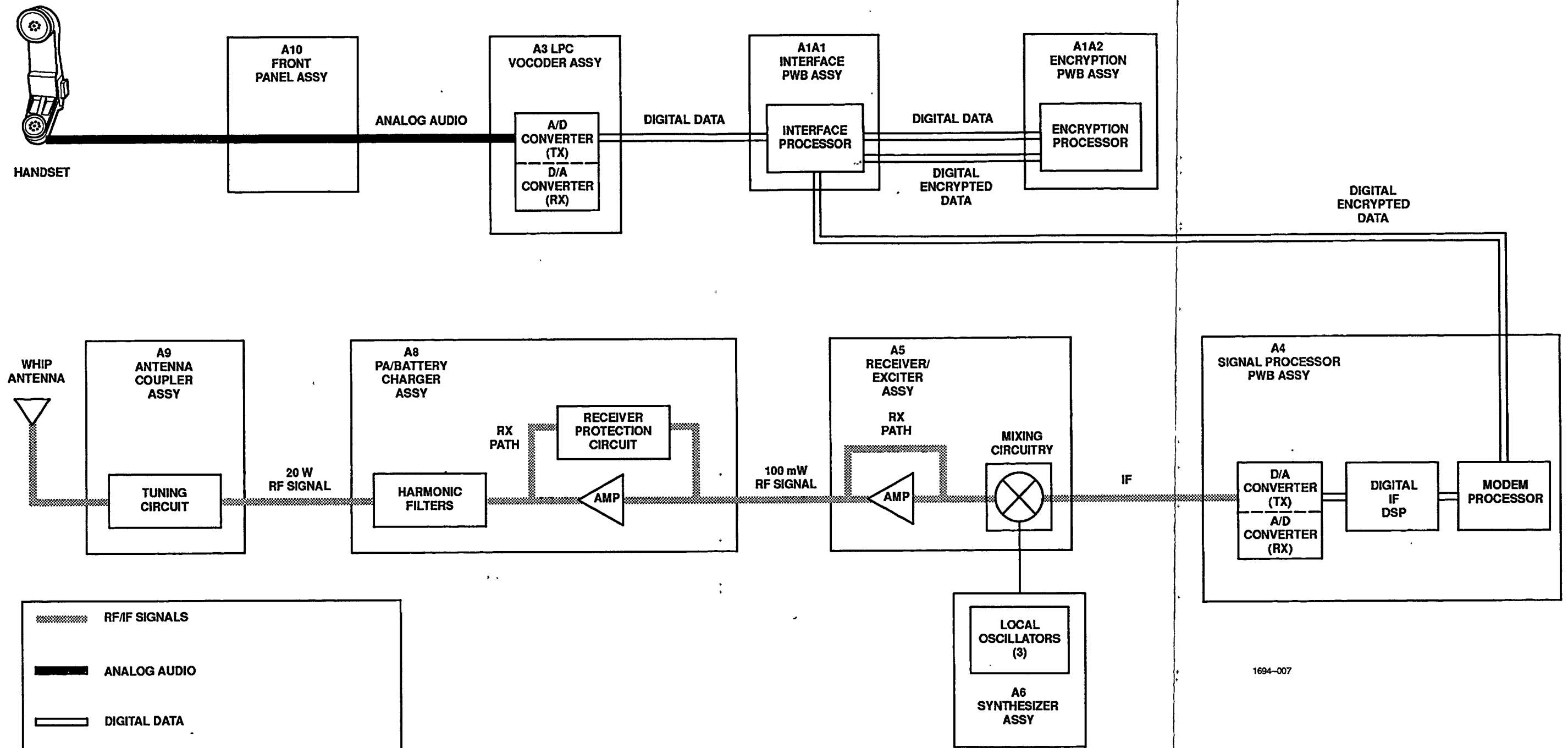

1694-007

Figure 3-5. Receiver-Transmitter Encrypted Digital Voice Simplified Functional Block Diagram

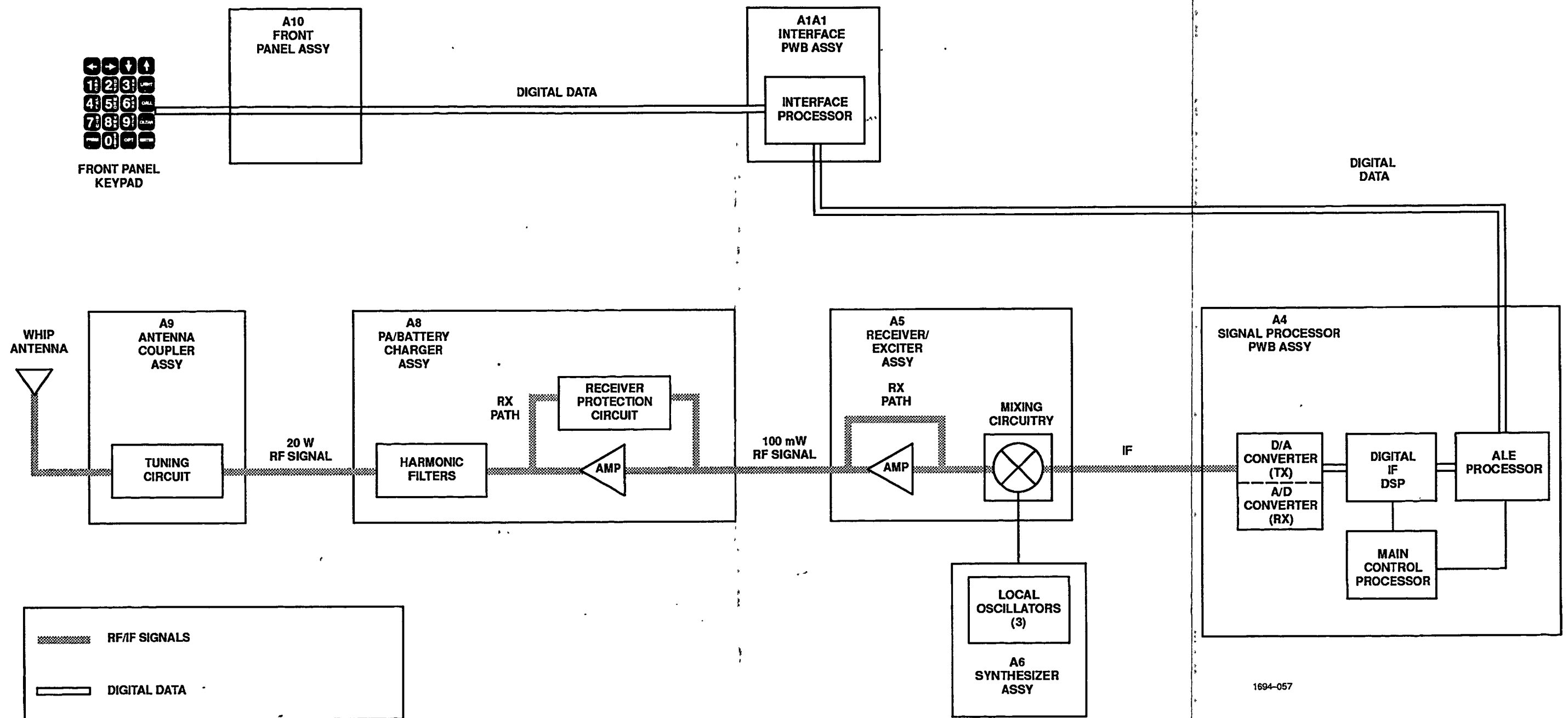

1694-057

Figure 3-6. Receiver-Transmitter
ALE Simplified
Functional Block Diagram

3.2.3.7 Frequency Hopping Functional Level Descriptions

Paragraph 3.2.3.7.1 provides a functional-level description of the receiver-transmitter when transmitting with frequency hopping enabled. Paragraph 3.2.3.7.2 provides a functional-level description of the receiver-transmitter when receiving with frequency hopping enabled. See Figure 3-7.

3.2.3.7.1 Transmitting with Frequency Hopping Enabled

Transmit audio from the handset passes through the A10 Front Panel Assembly to the A/D converter on the A3 LPC Vocoder Assembly. The digital data is passed to the LPC processor, which passes the data through the interface processor on the A1A1 Interface PWB Assembly to the modem processor on the A4 Signal Processor PWB Assembly. The modem processor creates a digital representation of a 39-tone waveform. This digital waveform is passed to the digital IF DSP, which generates a digital representation of a 6 kHz IF. This signal then passes through a D/A converter, where the digitized IF is converted into an analog signal. This signal is passed to the A5 Receiver/Exciter Assembly for conversion to an RF signal.

Mixing circuitry on the A5 Receiver/Exciter Assembly mixes the IF signal with signals from the local oscillators on the A6 Synthesizer Assembly. The resulting RF signal is in the frequency range of 1.6 MHz to 59.9999 MHz. This RF signal is amplified to approximately 100 mW before being output to the A8 PA/Battery Charger Assembly.

The A8 PA/Battery Charger Assembly amplifies the 100 mW RF signal to 20 watts. The 20-watt signal then passes through one of eight harmonic filters to reduce the level of unwanted harmonics. The 20-watt RF signal then passes through a tuning circuit on the A9 Antenna Coupler Assembly before being transmitted through the whip antenna.

The main control processor on the A4 Signal Processor PWB Assembly communicates with the modem processor and changes the frequency of one local oscillator on the A6 Synthesizer Assembly. Together, these processors and the local oscillator perform the frequency hopping function.

3.2.3.7.2 Receiving with Frequency Hopping Enabled

RF signals in the frequency range of 1.6 MHz to 59.9999 MHz are received by the receiver-transmitter at the whip antenna. These signals pass through the tuning circuit on the A9 Antenna Coupler Assembly and one of the harmonic filters on the A8 PA/Battery Charger Assembly. The RF signal then follows the RX path through the receiver protection circuit on the A8 PA/Battery Charger Assembly. These signals are then routed to the A5 Receiver/Exciter Assembly. The RF signal is mixed with signals from the local oscillators on the A6 Synthesizer Assembly. The result is an IF signal.

The IF signal is then converted to a digital representation of the IF signal by the A/D converter on the A4 Signal Processor PWB Assembly. The A/D converter passes this signal to the digital IF DSP, which removes the IF components of the signal. The digital signal is then processed by the modem processor, which demodulates the 39-tone signal. The resulting digital signal passes through the interface processor on the A1A1 Interface PWB Assembly and the LPC processor on the A3 LPC Vocoder Assembly. The signal then passes through the D/A converter on the A3 LPC Vocoder Assembly, resulting in an analog audio signal. The analog audio then passes through the A10 Front Panel Assembly, where it is routed to the handset.

The main control processor on the A4 Signal Processor PWB Assembly communicates with the the modem processor and changes the frequency of one local oscillator on the A6 Synthesizer Assembly. Together, these processors and the local oscillator perform the frequency hopping function.

3.2.3.8 Frequency Modulation (FM) Functional Level Descriptions

Paragraph 3.2.3.8.1 provides a functional level description of the receiver-transmitter when transmitting FM signals. Paragraph 3.2.3.8.2 provides a functional level description of the receiver-transmitter when receiving FM signals. See Figure 3-8.

3.2.3.8.1 Transmitting FM Signals

Audio enters the radio at the handset when it is keyed and spoken into. The audio signal is routed from the A10 Front Panel Assembly to the A/D converter on the A4 Signal Processor PWB Assembly for digitizing. The digital data is passed to a clipper circuit, and then a 150 Hz tone is added to the signal for use in receiver Tone Squelch. This signal then passes through a D/A converter, where the data is converted into FM transmit audio. This audio modulates one of the local oscillators on the A6 Synthesizer Assembly. The A4 Signal Processor PWB Assembly also digitally generates the FM Transmit (TX) IF, which is passed to the A5 Receiver/Exciter Assembly.

Mixing circuitry on the A5 Receiver/Exciter Assembly mixes the IF signal with signals from the local oscillators on the A6 Synthesizer Assembly. The resulting RF signal is in the frequency range of 1.6 MHz to 59.9999 MHz. This RF signal is amplified to approximately 100 mW before being output to the A8 PA/Battery Charger Assembly.

The A8 PA/Battery Charger Assembly amplifies the 100 mW RF signal to 20 watts. The 20-watt signal then passes through one of eight harmonic filters to reduce the level of unwanted harmonics. The 20-watt RF signal then passes through a tuning circuit on the A9 Antenna Coupler Assembly before being transmitted through the whip antenna.

3.2.3.8.2 Receiving FM Signals

RF signals in the frequency range of 1.6 MHz to 59.9999 MHz are received by the receiver-transmitter unit at the whip antenna. These signals pass through the tuning circuit on the A9 Antenna Coupler Assembly and one of the harmonic filters on the A8 PA/Battery Charger Assembly. The RF signal then follows the RX path through the receiver protection circuitry on the A8 PA/Battery Charger Assembly. These signals are then routed to the A5 Receiver/Exciter Assembly. The RF signal is demodulated on the A5 Receiver/Exciter Assembly. This audio signal is passed directly to the A/D converter on the A4 Signal Processor PWB Assembly.

The A/D converter passes the digital signal to an Automatic Gain Control (AGC) circuit for leveling, and the squelch circuit determines if there is any squelch information on the signal. The digital signal is then processed by the D/A converter, which creates an analog audio signal. The analog audio then passes through the A10 Front Panel Assembly, where it is routed to the handset.

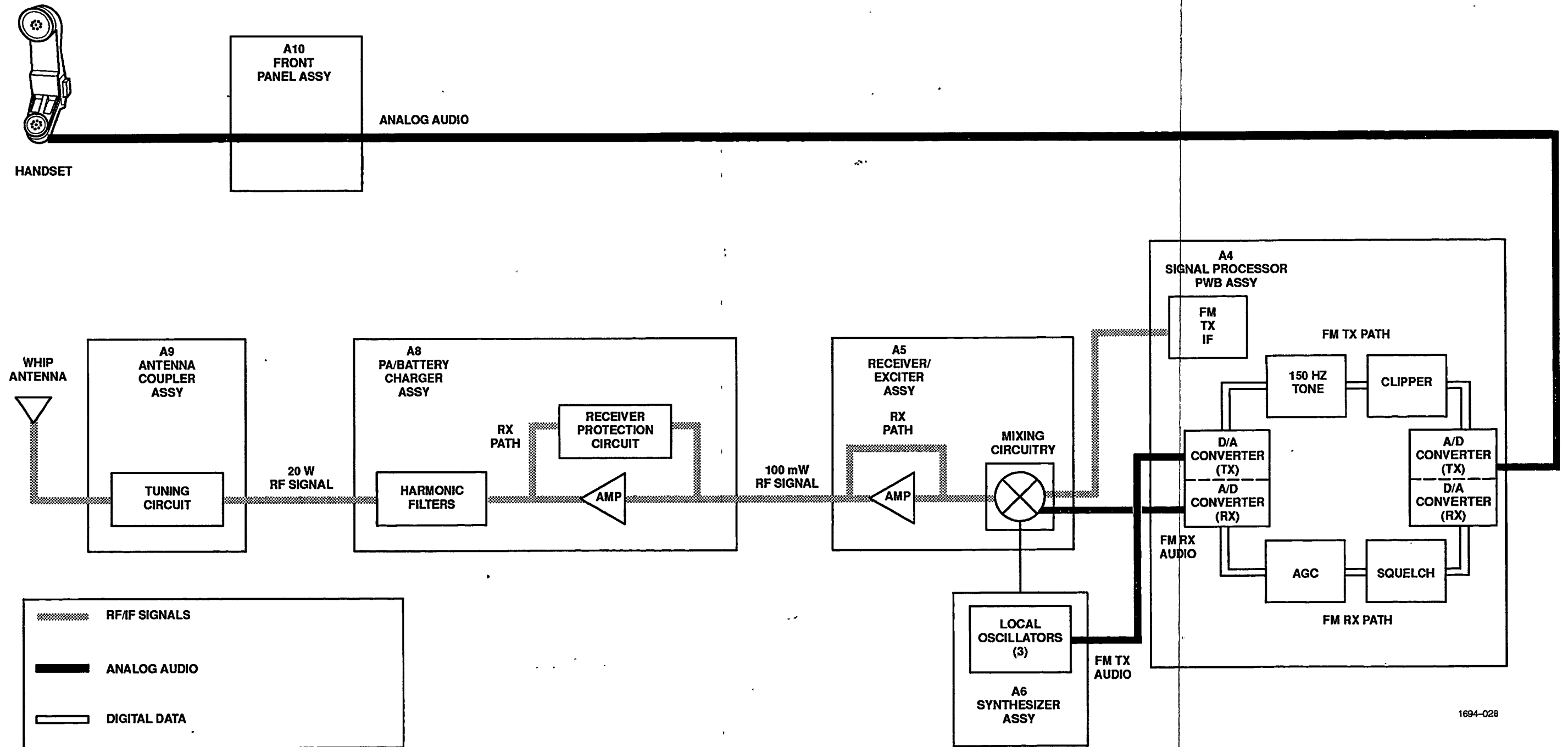

1694-028

Figure 3-8. Receiver-Transmitter Frequency Modulation Simplified Functional Block Diagram

3.3 MAJOR FUNCTION LEVEL DESCRIPTION

3.3.1 General

For detailed interconnections, refer to Chapter 5 for the following:

- Figure 5-4 – RF/IF/Audio/Digital Signal Path Diagram
- Figure 5-5 – Power Distribution Diagram
- Figure 5-6 – Receiver-Transmitter Interconnect Schematic Diagram

The major function level description is divided into the following signal paths:

- RF/IF/Audio/Digital Signal Path
- Control Path
- Power Distribution

The descriptions of these signal types are further divided as each assembly relates to the major signal path. Each signal type is not present on every assembly. Refer to Chapter 5, Paragraph 5.6, for the BIT description.

Paragraph 3.3.2 discusses the RF/IF/audio/digital signal path for a receiver-transmitter in analog clear voice mode. Paragraph 3.3.3 discusses the control signal path for a receiver-transmitter in analog clear voice mode. Paragraph 3.3.4 adds a detailed discussion of digital voice. Paragraph 3.3.5 adds a detailed discussion of AVS. Paragraph 3.3.6 adds a detailed discussion of encrypted digital data. Paragraph 3.3.7 adds a discussion of encrypted digital voice. Paragraph 3.3.8 adds a discussion of ALE. Paragraph 3.3.9 adds a discussion of frequency hopping. Paragraph 3.3.10 adds a discussion of FM. Finally, Paragraph 3.3.11 discusses power distribution within the receiver-transmitter.

3.3.2 RF/IF/Audio/Digital Signal Path (Analog Clear Voice)

Refer to Chapter 5, Figure 5-4. The following paragraphs describe the functions of each SRU as they relate to the transmit and receive signal paths for the receiver-transmitter. Paragraph 3.3.2.1 describes the RF/IF/audio/digital signal path for the unit when it is transmitting. Paragraph 3.3.2.2 describes the RF/IF/audio/digital signal path for the unit when it is receiving.

3.3.2.1 Transmit RF/IF/Audio/Digital Signal Path

To transmit using the receiver-transmitter, the radio operator keys, and speaks into, a handset connected to the front panel. This produces an audio signal which enters the A10 Front Panel Assembly.

3.3.2.1.1 A10 Front Panel Assembly

Audio enters the A10 Front Panel Assembly from the handset. The audio signal is filtered by a filter circuit and amplified by a microphone preamplifier (mic preamp). The audio switch then passes the audio signal to the A/D converter on the A4 Signal Processor PWB Assembly.

3.3.2.1.2 A4 Signal Processor PWB Assembly

Analog audio signals from the A10 Front Panel Assembly are digitized by the A/D converter. The digital data signal is then passed to the digital IF DSP. The digitized audio is then product modulated by a mixer and the Upper Sideband (USB)/Lower Sideband (LSB) Beat Frequency Oscillator (BFO). The undesired sideband is then digitally removed by a Finite Impulse Response (FIR) digital filter. The resulting signal is a digital representation of a 6 kHz IF. This digital signal passes through a D/A converter, resulting in a 6 kHz IF. This IF is then passed to the A5 Receiver/Exciter Assembly.

3.3.2.1.3 A5 Receiver/Exciter Assembly

The 6 kHz IF signal from the A4 Signal Processor PWB Assembly is passed to the RX Second Mixer, which mixes the signal with the 9.5 MHz Local Oscillator (LO3). The resulting signal passes through a +15 dB amplifier, AGC 2 circuit for leveling, a +8 dB amplifier, and an 8 kHz Bandpass Filter (BPF) with a center frequency of 9.5 MHz. The output of the bandpass filter enters the TX Second Mixer, which mixes the signal with the 71 MHz LO2. The resulting signal passes through a +15 dB amplifier, a +12 dB amplifier, and a 22 kHz BPF with a center frequency of 80.5 MHz. The resulting signal then enters the First Mixer, which mixes the signal with LO1. The signal from LO1 varies with transmit frequency. The resulting signal passes through a 60 MHz Low Pass Filter (LPF). The signal then passes through three exciter amplifiers, for a total gain of +43 dB.

The resulting signal is in the 1.6 MHz to 59.9999 MHz range, with an output level of 100 milliwatts. This RF signal is output to the A8 PA/Battery Charger Assembly.

3.3.2.1.4 A8 PA/Battery Charger Assembly

RF signals from the A5 Receiver/Exciter Assembly pass through a +15 dB amplifier and a +12 dB amplifier. This increases the RF power level from 100 mW to 20 watts. The RF signal then passes through an Amplitude Modulation (AM) High Pass Filter (Band 1 AM HPF) and one of seven harmonic filters (Bands 2 through 8), reducing the levels of unwanted harmonics. The filtered RF signal then passes through a directional coupler, which passes Voltage Standing Wave Ratio (VSWR) data to the main control processor on the A4 Signal Processor PWB Assembly. Finally, the 20-watt RF signal is passed to the A9 Antenna Coupler Assembly.

When the receiver-transmitter is attached to an external power amplifier, transmit RF from the exciter follows the RX path through the A8 PA/Battery Charger Assembly. This path bypasses the amplifiers, leaving the transmit signal at 100 mW.

3.3.2.1.5 A9 Antenna Coupler Assembly

Transmit RF signals from the A8 PA/Battery Charger Assembly pass through a discriminator circuit and an L-C tuning circuit, making the antenna appear as a 50-ohm, purely resistive load to the power amplifier. This maximizes power transmitted through the whip antenna and minimizes power reflected back to the power amplifier.

When the receiver-transmitter is attached to an external power amplifier and antenna coupler, transmit RF from the A8 PA/Battery Charger Assembly follows the coupler bypass path through the A9 Antenna Coupler Assembly. This path bypasses the tuning circuit and the discriminator circuit. In this situation, 100 mW exciter RF passes directly out of the receiver-transmitter antenna port to the external power amplifier.

3.3.2.2 Receive RF/IF/Audio/Digital Signal Path

A modulated RF signal in the frequency range of 1.6 MHz to 59.9999 MHz is received at whip antenna. The signal is then routed to the A9 Antenna Coupler Assembly.

3.3.2.2.1 A9 Antenna Coupler Assembly

Receive RF signals from the A8 PA/Battery Charger Assembly pass through the L-C tuning circuit and the discriminator circuit. The receive RF signal is then passed to the A8 PA/Battery Charger Assembly.

When the receiver-transmitter is attached to an external power amplifier and antenna coupler, receive RF from the whip antenna follows the coupler bypass path through the A9 Antenna Coupler Assembly. This path bypasses the tuning circuit and the discriminator circuit.

3.3.2.2.2 A8 Power Amplifier/Battery Charger Assembly

RF signals from the A9 Antenna Coupler Assembly pass through the directional coupler, one of seven harmonic filters (Bands 2 through 8), and the AM HPF (Band 1 AM). The RF signal then follows the RX path through the receiver protection circuit, limiting the strength of receive signals to no more than +7 dBm. A user-selectable RF preamplifier with +13 dB gain is the final function performed on the receive signal before leaving the A8 PA/Battery Charger Assembly and going to the A5 Receiver/Exciter Assembly.

3.3.2.2.3 A5 Receiver/Exciter Assembly

The receive RF signal from the A8 PA/Battery Charger Assembly follows the receive path around the exciter amplifiers before being low pass filtered and mixed by the first mixer with the 80.5 MHz LO1. The resulting IF signal passes through a 22 kHz BPF with a center frequency of 80.5 MHz. The IF is then amplified +14.3 dB, leveled by AGC 1 circuit, and amplified another +7 dB.

The IF signal is then mixed by RX second mixer with the 71 MHz L02. The resulting signal is then amplified +15 dB and leveled by AGC 2 circuit. The IF signal is then amplified +8 dB before passing through an 8 kHz BPF with a center frequency of 9.5 MHz. The signal is then amplified +6 dB before being split into two paths, with one path attenuated 36 dB with respect to the other path. Both IF signals are independently mixed by the third mixer to a 30 kHz (analog signals) or 36 kHz (digital signals) third IF signal. Both IF signals are then amplified +23.5 dB before being passed to the A4 Signal Processor PWB Assembly.

3.3.2.2.4 A4 Signal Processor PWB Assembly

The IF signals from the A5 Receiver/Exciter Assembly are digitized on the A4 Signal Processor PWB Assembly by a D/A converter, resulting in a digital representation of the IF. This digital IF signal is then processed by the digital IF DSP, resulting in digital data that represents an analog audio signal. This digital data is processed by the D/A converter. The resulting analog audio signal is then passed to the A10 Front Panel Assembly.

3.3.2.2.5 A10 Front Panel Assembly

The audio signal from the A4 Signal Processor PWB Assembly enters the A10 Front Panel Assembly, where it is filtered before being output to the handset.

3.3.3 Control Paths (Analog Clear Voice)

Refer to Chapter 5, Figure 5-4 . The following paragraphs describe the functions of each SRU as they relate to the control paths. The control paths are where the A10 Front Panel Assembly, A6 Synthesizer Assembly, and the main control processor on the A4 Signal Processor PWB Assembly interact with the rest of the assemblies in the receiver-transmitter.

3.3.3.1 A10 Front Panel Assembly

This assembly is the interface between the operator and the receiver-transmitter. It is the point of entry for operating instructions, such as frequency, bandwidth, mode, etc., and is where operating parameters and fault codes are displayed. Operator entries are made via the front panel keypad. These instructions are then routed to the interface control processor on the A1A1 Interface PWB Assembly.

3.3.3.2 A1A1 Interface PWB Assembly

Instructions and control information entered by the operator at the A10 Front Panel Assembly are routed directly to the A1A1 Interface PWB Assembly.

A second source of instructions and control information is an external computer terminal. Control information and instructions enter the receiver-transmitter via the DATA connector on the receiver-transmitter front panel. This control information is also routed directly to the A1A1 Interface PWB Assembly. Remote control data usually

comes from an RS-232 or MIL-188 terminal, or from a personal computer running terminal emulation software. This data is translated to digital levels. The serial data is then formatted into a data packet and passed to the interface control processor. The interface control processor then passes this data packet to the main control processor on the A4 Signal Processor PWB Assembly via the internal High Speed Serial Bus (HSSB).

3.3.3.3 A1A2 Encryption PWB Assembly

Digital data requiring encryption is passed directly from the interface control processor on the A1A1 Interface PWB Assembly to the encryption processor on the A1A2 Encryption PWB Assembly via the dual port Random Access Memory (RAM). Encrypted digital data then returns to the interface control processor via the dual port RAM.

3.3.3.4 A4 Signal Processor PWB Assembly

When the main control processor receives a data packet from the interface control processor (via the HSSB), it immediately examines the data packet. Any control commands for the ALE processor, modem control processor, AGC processor, or LPC/AVS processor are immediately output to the HSSB for use by the appropriate processor.

The main control processor then examines the remaining information from the data packet. It determines the nature of the information and converts the remaining data into a series of digital commands. It then outputs these commands to either the A8 PA/Battery Charger Assembly or to an external power amplifier (if one is connected) and to the HSSB for transmission to the appropriate processors.

The local oscillators on the A6 Synthesizer Assembly (LO1, LO2, and LO3) are controlled via control lines to the main control processor on the A4 Signal Processor PWB Assembly.

3.3.3.5 A5 Receiver/Exciter Assembly

The mixers on the A5 Receiver/Exciter Assembly are controlled via control lines to the local oscillators.

3.3.3.6 A6 Synthesizer Assembly

The local oscillators on the A6 Synthesizer Assembly (LO1, LO2, and LO3) are controlled via control lines to the main control processor on the A4 Signal Processor PWB Assembly.

3.3.4 Digital Voice Signal Paths

The following paragraphs explain the differences between analog clear voice signal paths and ALE signal paths.

3.3.4.1 RF/IF/Audio/Digital Signal Paths (Digital Voice)

During transmit, analog audio enters the A10 Front Panel Assembly. The audio switch on the A10 Front Panel Assembly routes the audio signal to the A/D converter on the A3 LPC Vocoder Assembly. The resulting digital signal is sent to the LPC/AVS processor. The signal then passes to the modem processor via the HSSB. Forward Error Correction (FEC) data is then added to the data stream before being passed to the Quaternary Phase Shift Keying (QPSK) circuit on the Fast Fourier Transform (FFT) DSP, where the 39-tone information is added to the digital signal. The resulting signal is a digital representation of a 39-tone modem waveform. This signal is input to the digital IF DSP. The rest of the transmit signal path is the same as with analog clear voice.

During receive, the digital signal from the digital IF DSP on the A4 Signal Processor PWB Assembly is passed to the FFT DSP mixer. The mixer and the FFT reference eliminate any errors introduced to the signal during transmission. The data is then decoded by the FEC circuit before being passed to the modem control processor. The rest of the receive audio path is the reverse of the digital voice transmit path.

3.3.4.2 Control Signal Paths (Digital Voice)

During digital voice operation, the LPC/AVS processor works with the modem processor, the main control processor, the AGC processor, and the interface control processor. Data is passed among these processors via the HSSB.

3.3.5 AVS Signal Paths

The following paragraphs explain the differences between analog clear voice signal paths and AVS signal paths.

3.3.5.1 RF/IF/Audio/Digital Signal Paths (AVS)

During transmit, analog audio enters the A10 Front Panel Assembly. The audio switch on the A10 Front Panel Assembly routes the audio signal to the A/D converter on the A3 LPC Vocoder Assembly. The resulting digital signal is sent to the LPC/AVS processor. The LPC/AVS processor uses digital signal processing to scramble both the frequency and timing of the speech signal. The LPC/AVS processor then passes the encrypted audio signal directly to the A/D converter on the A4 Signal Processor PWB Assembly. The rest of the transmit signal path is the same as with analog clear voice.

During receive, encrypted audio from the D/A converter on the A4 Signal Processor PWB Assembly is decrypted by the LPC/AVS processor on the A3 LPC Vocoder Assembly. The decrypted digital data is passed to the D/A converter on A3 LPC Vocoder Assembly. Analog audio is then passed to the A10 Front Panel Assembly, where it is routed to the handset.

3.3.6 Encrypted Digital Data Signal Paths

The following paragraphs explain the differences between analog clear voice signal paths and encrypted digital data signal paths.

3.3.6.1 RF/IF/Audio/Digital Signal Paths (Encrypted Digital Data)

Digital data from an external computer terminal passes through the A10 Front Panel Assembly to the interface control processor on the A1A1 Interface PWB Assembly. The interface control processor passes the digital data to the encryption processor on the A1A2 Encryption PWB Assembly via the dual port RAM. The encryption processor passes the encrypted digital data back through the interface control processor to the modem control processor on the A4 Signal Processor PWB Assembly via the dual port RAM. FEC data is then added to the data stream before being passed to the QPSK circuit on the FFT DSP, where the 39-tone information is added to the digital signal. The resulting signal is a digital representation of a 39-tone modem waveform. This signal is input to the digital IF DSP. The rest of the transmit signal path is the same as with analog clear voice.

During receive, the digital signal from the digital IF DSP on the A4 Signal Processor PWB Assembly is passed to the FFT DSP mixer. The mixer and the FFT reference eliminate any errors introduced to the signal during transmission. The data is then decoded by the FEC circuit before being passed to the modem control processor. The rest of the receive audio path is the reverse of the encrypted digital data transmit path.

3.3.7 Encrypted Digital Voice Signal Paths

The following paragraphs explain the differences between analog clear voice signal paths and encrypted digital voice signal paths.

3.3.7.1 RF/IF/Audio/Digital Signal Paths (Encrypted Digital Voice)

During transmit, the audio switch on the A10 Front Panel Assembly diverts transmit audio to the A3 LPC Vocoder Assembly. Audio is then sampled and converted to a digitized audio signal by the A/D converter. This digital data is then processed by the LPC/AVS processor, digitally reducing the effective data rate of voice communications from 96,000 bits per second (bps) to 2,400 bps.

The digital data received from the A3 LPC Vocoder Assembly is routed through the A1A1 Interface PWB Assembly to the A1A2 Encryption PWB Assembly via the HSSB. This data is encrypted by the encryption processor using the encryption key stored in memory. Once the digitized audio has been encrypted, it passes back through the A1A1 Interface PWB Assembly to the modem control processor on the A4 Signal Processor PWB Assembly via the HSSB. FEC data is then added to the data stream before being passed to the QPSK circuit on

the FFT DSP, where the 39-tone information is added to the digital signal. The resulting signal is a digital representation of a 39-tone modem waveform. The signal is then input to the digital IF DSP. The rest of the transmit signal path is the same as with analog clear voice.

During receive, the digital signal from the digital IF DSP on the A4 Signal Processor PWB Assembly is passed to the FFT DSP mixer. The mixer and the FFT reference eliminate any errors introduced to the signal during transmission. The data is then decoded by the FEC circuit before being passed to the modem control processor. The rest of the receive audio path is the reverse of the encrypted digital voice transmit path.

3.3.8 ALE Signal Paths

The following paragraph explains the differences between analog clear voice signal paths and ALE signal paths.

3.3.8.1 RF/IF/Audio/Digital Signal Paths (ALE) During Link Establishment

The operator presses the CALL button on the receiver-transmitter front panel. The display/keypad processor generates a command that is received by the interface control processor. The interface control processor relays this command to the ALE processor on the A4 Signal Processor PWB Assembly via the HSSB. The ALE processor commands the main control processor, via the HSSB, to configure the receiver-transmitter to the correct channel transmit frequency. Once this has been accomplished, the ALE processor sends digital data to the digital IF DSP, which generates a digital representation of a 6 kHz IF. This signal then passes through a D/A converter, where the digitized IF is converted into an analog signal. This signal is passed to the A5 Receiver/Exciter Assembly for conversion to an RF signal.

Mixing circuitry on the A5 Receiver/Exciter Assembly mixes the IF signal with signals from the local oscillators on the A6 Synthesizer Assembly. The resulting RF signal is in the frequency range of 1.6 MHz to 59.9999 MHz. This RF signal is amplified to approximately 100 mW before being output to the A8 PA/Battery Charger Assembly.

The A8 PA/Battery Charger Assembly amplifies the 100 mW RF signal to 20 watts. The 20-watt signal then passes through one of eight harmonic filters to reduce the level of unwanted harmonics. The 20-watt RF signal then passes through a tuning circuit on the A9 Antenna Coupler Assembly before being transmitted through the whip antenna.

During receive, the radio is scanning its channel set. The ALE processor commands the main control processor, via the HSSB, to configure the receiver-transmitter to a particular channel.

Once this has been accomplished, RF signals at that channel's frequency (1.6 MHz to 59.9999 MHz) are received by the receiver-transmitter at the whip antenna. These signals pass through the tuning circuit on the A9 Antenna Coupler Assembly and one of the harmonic filters on the A8 PA/Battery Charger Assembly. The RF signal then follows the RX path through the receiver protection circuitry on the A8 PA/Battery Charger Assembly. These signals are then routed to the A5 Receiver/Exciter Assembly. The RF signal is mixed with signals from the local oscillators on the A6 Synthesizer Assembly. The result is an IF signal.

The IF signal is then converted to a digital representation of the IF signal by the A/D converter on the A4 Signal Processor PWB Assembly. The A/D converter passes this signal to the digital IF DSP which removes the IF components of the signal. The digital signal is then passed to the ALE processor which checks to see if valid ALE data is present. If valid ALE data is not present, the ALE processor commands the main control processor to configure the receiver-transmitter to the next channel. If valid ALE data is present, the ALE processor commands the receiver-transmitter to transmit a link response.

3.3.9 Frequency Hopping Signal Paths

The following paragraphs explain the differences between analog clear voice signal paths and frequency hopping signal paths.

3.3.9.1 RF/IF/Audio/Digital Signal Paths (Frequency Hopping)

During transmit, analog audio enters the A10 Front Panel Assembly. The audio switch on the A10 Front Panel Assembly routes the audio signal to the A/D converter on the A3 LPC Vocoder Assembly. The resulting digital signal is sent to the LPC/AVS processor. The signal then passes through the A1A1 Interface PWB Assembly via the HSSB before reaching the modem processor on the A4 Signal Processor PWB Assembly. FEC data is then added to the data stream before being passed to the QPSK circuit on the FFT DSP, where the 39-tone information is added to the digital signal. The resulting signal is a digital representation of a 39-tone modem waveform. This signal is input to the digital IF DSP. The rest of the transmit signal path is the same as with analog clear voice.

During receive, the digital signal from the digital IF DSP on the A4 Signal Processor PWB Assembly is passed to the FFT DSP mixer. The mixer and the FFT reference eliminate any errors introduced to the signal during transmission. The data is then decoded by the FEC circuit before being passed to the modem control processor. The rest of the receive audio path is the reverse of the frequency hopping transmit path.

3.3.9.2 Control Signal Paths (Frequency Hopping)

During frequency hopping operation, the LPC/AVS processor works with the modem processor, the main control processor, and the interface control processor. Data is passed among these processors via the HSSB. The main control processor also varies the frequency of local oscillator LO1 during frequency hopping operation.

3.3.10 FM Signal Paths

The following paragraphs explain the differences between analog clear voice signal paths and frequency hopping signal paths.

3.3.10.1 RF/IF/Audio/Digital Signal Paths (FM)

During transmit, analog audio signals from the A10 Front Panel Assembly are digitized by the A/D converter on the A4 Signal Processor PWB Assembly. The digital signal from the A/D converter passes through a clipper circuit. A 150-Hz tone used by the receiving station during Tone Squelch operation is then mixed with the clipper output. The digital signal then passes through the D/A converter on the A4 Signal Processor PWB Assembly. The resulting FM TX audio is used to modulate the 71 MHz LO2 on the A6 Synthesizer Assembly.

During receive, the received signal is mixed down to audio on the A5 Receiver/Exciter Assembly. After passing through the RX second mixer and the +15 dB amplifier, the IF signal is mixed with the 9.5-MHz LO3. The signal is then amplified, passed through an FM discriminator circuit, and low-pass filtered by a 5-kHz LPF. The FM audio signal is then digitized by the A/D converter on the A4 Signal Processor PWB Assembly. The signal is then attenuated 24 dB by an attenuator, and AGC is applied. The signal is then checked for squelch activity by the squelch circuit. The digital signal is then converted back to analog by the D/A converter. Receive analog audio is then sent through the A10 Front Panel Assembly, where it is routed to the handset.

3.3.11 Power Distribution Paths

Power distribution consists of converting a +26 Vdc input (or +20 Vdc to +32 Vdc battery input) to +5 Vdc, +6.8 Vdc, +16.5 Vdc, and -12 Vdc, and distributing these voltages to the other receiver-transmitter assemblies, as discussed in the following paragraphs.

3.3.11.1 AC Line Voltage Path

AC line voltage is not directly applied to the receiver-transmitter.

3.3.11.2 +26 Vdc Path

A power supply or external power amplifier provides a +26 Vdc to the receiver-transmitter via the front panel PA connector. When used in manpack configuration, +20 Vdc to +32 Vdc from the attached batteries enters the receiver-transmitter via the battery connectors on the rear panel. The input voltage is applied directly to the A7 Power Supply Assembly. The A10 Front Panel Assembly, A8 PA/Battery Charger Assembly, and A5 Receiver/Exciter Assembly also use this voltage directly.

3.3.11.3 Power Supply Assembly A7

The A7 Power Supply Assembly filters and converts the input voltage into the following voltages:

- +5 Vdc
- +6.8 Vdc
- +16.5 Vdc (unregulated)
- -12 Vdc

From here, the voltages are distributed to the receiver-transmitter assemblies as described in the following paragraphs.

3.3.11.4 Voltages and Assemblies

The following paragraphs discuss the assemblies that use the four power supply voltages.

3.3.11.4.1 Regulated +5 Vdc Line

The regulated +5 Vdc line is used by the following assemblies:

- A1A1 Interface PWB Assembly
- A1A2 Encryption PWB Assembly
- A3 LPC Vocoder Assembly
- A4 Signal Processor PWB Assembly
- A5 Receiver/Exciter Assembly
- A6 Synthesizer Assembly
- A8 PA/Battery Charger Assembly
- A9 Antenna Coupler Assembly
- A11 Motherboard Assembly

3.3.11.4.2 Regulated +6.8 Vdc Line

The regulated +6.8 Vdc line is used by the following assemblies:

- A6 Synthesizer Assembly
- A11 Motherboard Assembly

3.3.11.4.3 Unregulated +16.5 Vdc Line

The unregulated +16.5 Vdc line is used by the following assemblies:

- A1A1 Interface PWB Assembly
- A1A2 Encryption PWB Assembly
- A3 LPC Vocoder Assembly
- A4 Signal Processor PWB Assembly
- A5 Receiver/Exciter Assembly
- A6 Synthesizer Assembly
- A8 PA/Battery Charger Assembly
- A9 Antenna Coupler Assembly
- A10 Front Panel Assembly
- A11 Motherboard Assembly

3.3.11.4.4 Regulated -12 Vdc Line

The regulated -12 Vdc line is used by the following assemblies:

- A1A1 Interface PWB Assembly
- A3 LPC Vocoder Assembly
- A4 Signal Processor PWB Assembly
- A5 Receiver/Exciter Assembly
- A6 Synthesizer Assembly
- A8 PA/Battery Charger Assembly
- A9 Antenna Coupler Assembly
- A10 Front Panel Assembly
- A11 Motherboard Assembly

CHAPTER 4

SCHEDULED MAINTENANCE

4.1 INTRODUCTION

This chapter provides information required to perform scheduled maintenance procedures on the receiver-transmitter.

4.1.1 Scheduled Maintenance Procedure List

Table 4-1 lists the scheduled maintenance procedures for the receiver-transmitter. The table is divided into the following columns:

- a. Column 1 – Paragraph Number, where the procedure begins
- b. Column 2 – Scheduled Maintenance Procedure, describes the test to be performed
- c. Column 3 – Periodicity, interval in which the procedure must be performed (that is, daily, weekly, monthly, etc.)

Table 4-1. Scheduled Maintenance Procedures

Paragraph Number	Scheduled Maintenance Procedure	Periodicity
4.2.1	Receive Sensitivity	12 months
4.2.2	Power Output	12 months
4.2.3	Frequency Accuracy	12 months
4.2.4	Lithium Battery Check	6 months

4.2 SCHEDULED MAINTENANCE PROCEDURES

The following paragraphs contain information about tests to be performed on a receiver-transmitter as part of scheduled maintenance.

4.2.1 Receive Sensitivity Test

The following paragraphs provide instructions for performing the receive sensitivity test as part of scheduled maintenance. The receive sensitivity test confirms the proper operation and alignment of the A5 Receiver/Exciter Assembly.

4.2.1.1 Required Equipment

Table 4-2 lists the equipment required to perform the receive sensitivity test.

Table 4-2. Receive Sensitivity Test Required Equipment

Reference	Item Name	Part Number	Cage Code	Quantity
1	Signal Generator, RF	8657A	28480	1
2	Adapter, N-type (m) to BNC (f)	M55339/20-00201	81349	1
3	Cable Assembly, RF, BNC (m)	10503A	28480	2
4	Cable Assembly, DC Power	10394-9010	14304	1
5	Breakout Box	1008-1100	14304	1
6	Audio Analyzer	8903B	28480	1
7	Cable Assembly, Auxiliary	10372-9850	14304	1
8	Power Supply	6268B	28480	1

4.2.1.2 Test Procedure

Perform the following procedure to test the sensitivity of the receiver-transmitter:

- a. Set up the test bed radio system as shown in Figure 4-1.
- b. Set the signal generator to a frequency of 1.601 MHz.



If a power amplifier is installed in the test circuit, provide adequate Radio Frequency (RF) protection to the input of the signal generator.

- c. Set the signal generator to an output level of -110 dBm.
- d. Set the input section of the audio analyzer to measure dB SINAD.
- e. Program the receiver-transmitter to 1.6 MHz and Upper Sideband (USB) modulation.
- f. With the signal generator set to 1.6010 MHz, the SINAD (signal + noise + distortion/noise + distortion) should be greater than 10 dB SINAD at -110 dB of signal, with internal preamplifier OFF. If SINAD measures out of specification, proceed to non-Built-In Test (BIT) troubleshooting procedures in Chapter 5, Paragraph 5.2.3.
- g. Repeat this measurement with the following frequency settings:

Signal Generator	R/T Frequency
15.001 MHz	15.0000 MHz
29.001 MHz	29.0000 MHz
30.101 MHz	30.1000 MHz
46.601 MHz	46.6000 MHz
59.701 MHz	59.7000 MHz

If SINAD measures out of specification, proceed to the non-BIT troubleshooting procedures in Chapter 5, Paragraph 5.2.3.

- h. Program the receiver-transmitter to 2.1 MHz and USB modulation.
- i. With the signal generator set to 2.1010 MHz, the SINAD (signal + noise + distortion/noise + distortion) should be greater than 10 dB SINAD at -115 dB of signal, with internal preamplifier ON. If SINAD measures out of specification, proceed to the non-BIT troubleshooting procedures in Chapter 5, Paragraph 5.2.3.
- j. Repeat this measurement with the following frequency settings:

Signal Generator	R/T Frequency
15.001 MHz	15.0000 MHz
29.001 MHz	29.0000 MHz
30.101 MHz	30.1000 MHz
46.601 MHz	46.6000 MHz
59.701 MHz	59.7000 MHz

If SINAD measures out of specification, proceed to the non-BIT troubleshooting procedures in Chapter 5, Paragraph 5.2.3.

- k. Program the receiver-transmitter to 31.05 MHz and Frequency Modulation (FM).
- l. With the signal generator set to 31.05 MHz, FM modulate the generator with a 1 kHz tone at 8 kHz deviation. The SINAD (signal + noise + distortion/noise + distortion) should be greater than 10 dB SINAD at -113 dB of signal, with internal preamplifier ON. If SINAD measures out of specification, proceed to the non-BIT troubleshooting procedures in Chapter 5, Paragraph 5.2.3.
- m. Repeat this measurement with the following frequency settings:

Signal Generator and R/T
46.250 MHz
53.100 MHz

If SINAD measures out of specification, proceed to the non-BIT troubleshooting procedures in Chapter 5, Paragraph 5.2.3.

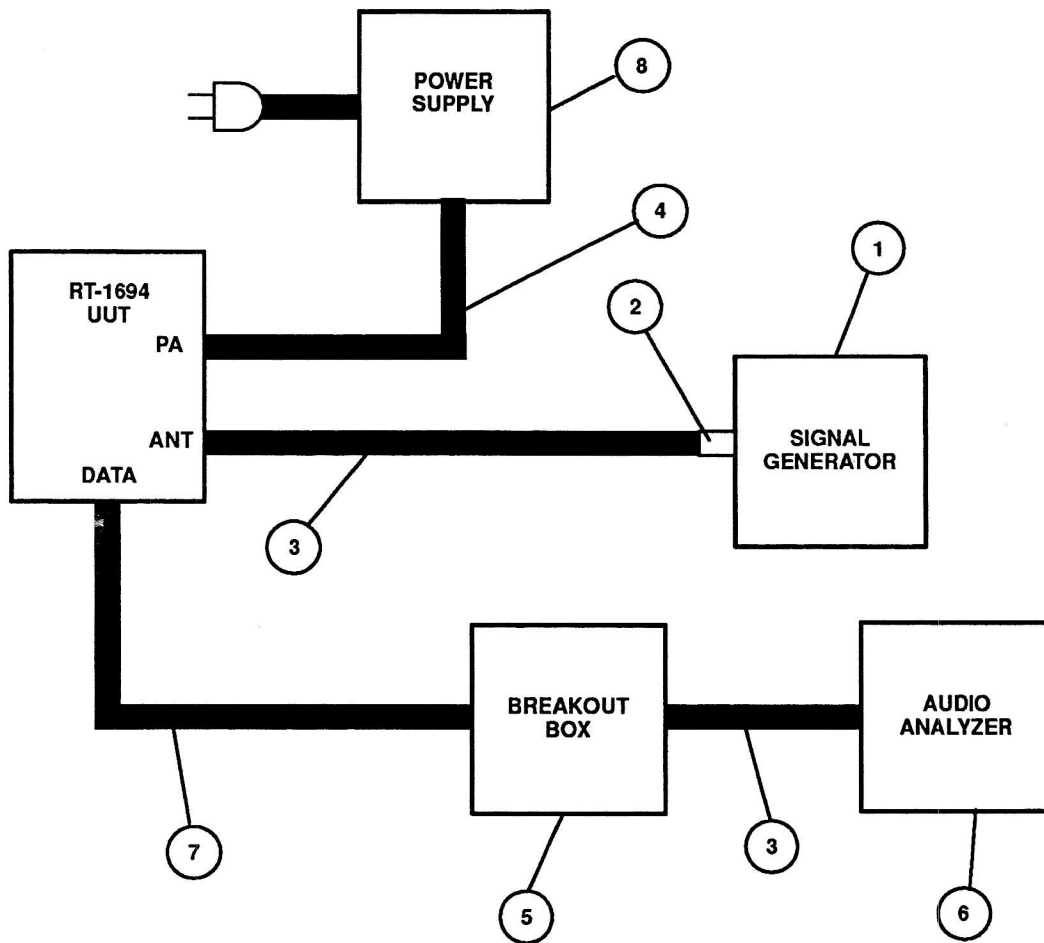

1694-029A

Figure 4-1. Receive Sensitivity Test Set Up

4.2.2 Power Output Measurement

The following paragraphs provide instructions to measure the power output of the receiver-transmitter as part of scheduled maintenance. The power output test verifies that the receiver-transmitter is transmitting with the proper power level.

4.2.2.1 Required Equipment

Table 4-3 lists the equipment required to perform the power output measurement.

Table 4-3. Power Output Measurement Required Equipment

Reference	Item Name	Part Number	Cage Code	Quantity
1	Handset (H-250/U)	10075-1344-01	14304	1
2	Battery Eliminator	10372-9330	14304	1
3	Power Supply	6268B	28480	1
4	Cable Assembly, RF, BNC (m)	10503A	28480	1
5	Adapter, N-type (m) to BNC (f)	M55339/20-00201	81349	1
6	Power Meter, RF	437B	28480	1
7	Power Sensor	8482B	28480	1
8	Attenuator	77B6-30	70998	1

4.2.2.2 Test Procedure

Perform the following procedure to measure the output power of the receiver-transmitter:

- a. Set up the test bed radio system as shown in Figure 4-2.
- b. Configure the receiver-transmitter as listed in Table 4-4.
- c. Using the handset, key the receiver-transmitter and verify that the output level is +43 dBm +2.0/-1.0 dB as measured on the RF power meter (+13 dBm with 30 dB of attenuation). If the output power measures out of specification, proceed to the non-BIT troubleshooting procedures in Chapter 5, Paragraph 5.2.3.
- d. Repeat this measurement with the receiver-transmitter set to the following transmit frequencies:
 - 15.0000 MHz
 - 29.0000 MHz
 - 31.1000 MHz
 - 46.6000 MHz
 - 59.7000 MHz

Table 4-4. Receiver-Transmitter Settings for Power Output Test

Control	Setting
Function Switch	SSB
Mode	CW
Power	High
Digital Voice	OFF
Internal Coupler	BYPASS
Receiver Preamplifier	BYPASS
Modem	OFF
Squelch	OFF
Encryption	OFF
RX Frequency	1.6 MHz
TX Frequency	1.6 MHz
RF Gain	100%
AGC	Fast
IF BW	0.35 kHz

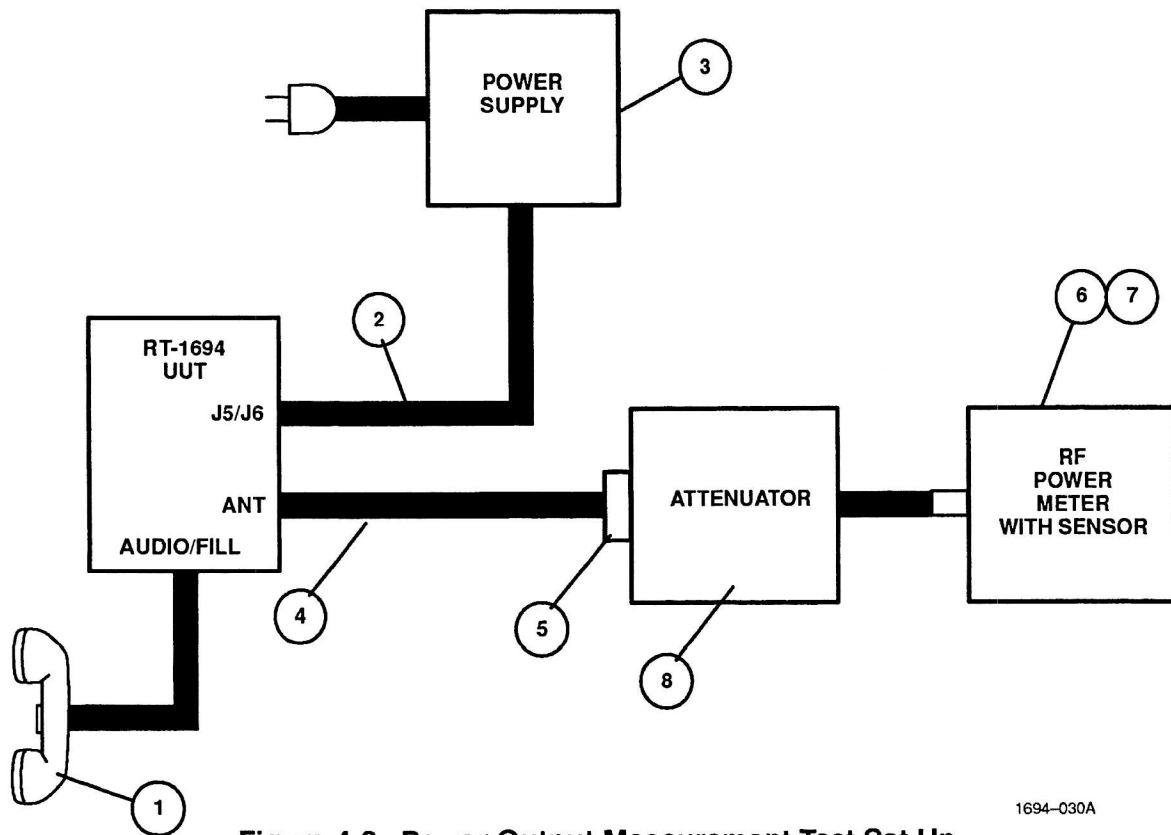

Figure 4-2. Power Output Measurement Test Set Up

4.2.3 Frequency Accuracy Measurement

The following paragraphs provide instructions to measure the frequency accuracy of the receiver-transmitter as part of scheduled maintenance. The frequency accuracy test verifies that the A6 Synthesizer Assembly is producing accurate signals.

4.2.3.1 Required Equipment

Refer to Table 4-5 for a list of the equipment required to perform the transmit frequency measurement.

Table 4-5. Transmit Frequency Measurement Required Equipment

Reference	Item Name	Part Number	Cage Code	Quantity
1	Handset (H-250/U)	10075-1344-01	14304	1
2	Cable Assembly, DC Power	10394-9010	14304	1
3	Power Supply	6268B	28480	1
4	Cable Assembly, RF, BNC (m)	10503A	28480	2
5	Adapter, N-type (m) to BNC (f)	M55339/20-00201	81349	2
6	Attenuator	77B6-30	70998	1
7	Frequency Counter	5385A	28480	1

4.2.3.2 Test Procedure

Perform the following procedure to measure the transmit frequency of the receiver-transmitter:

- a. Set up the test bed radio system as shown in Figure 4-3.
- b. Configure the receiver-transmitter as listed in Table 4-6.
- c. Using the handset, key the receiver-transmitter. The output frequency should be 29.900000 MHz \pm 12 Hz as measured on the frequency counter. If the frequency is not within specification, proceed to the non-BIT troubleshooting procedures in Chapter 5, Paragraph 5.2.3.

Table 4-6. Receiver-Transmitter Settings for Power Output Test

Control	Setting
Function Switch	SSB
Mode	CW
Power	High
RX Frequency	29.9000 MHz
TX Frequency	29.9000 MHz
BFO	0000 Hz

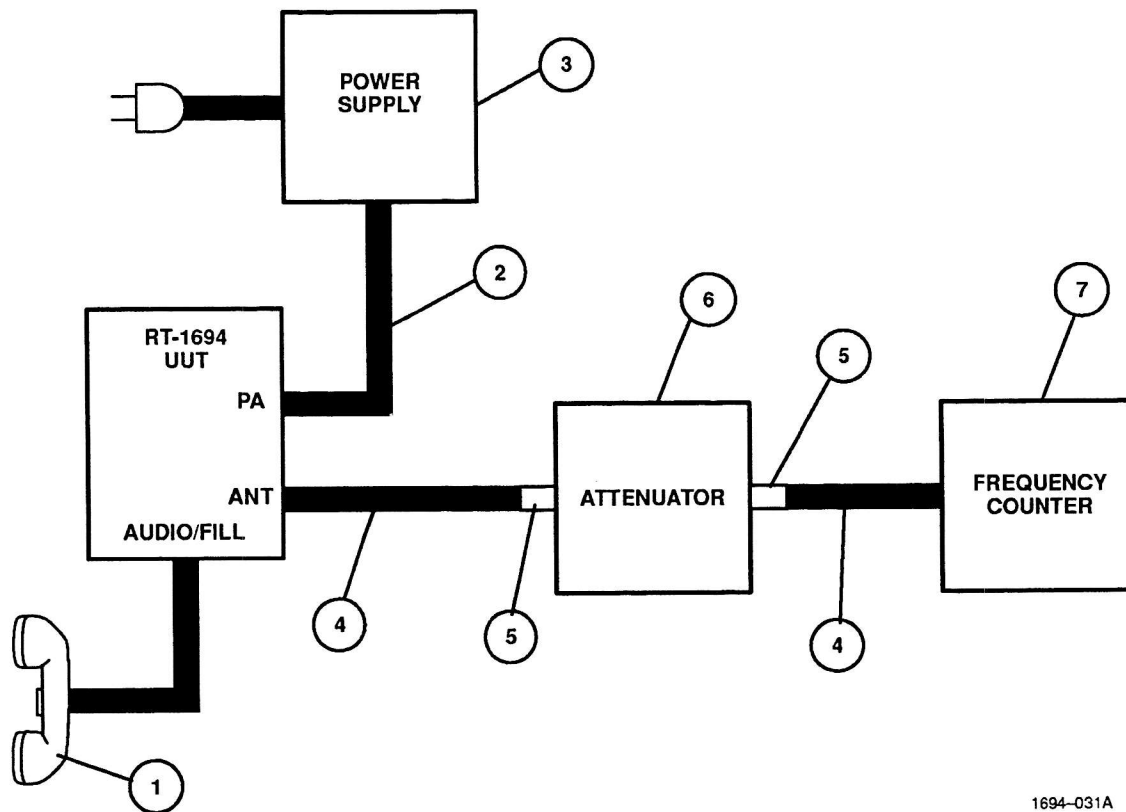

1694-031A

Figure 4-3. Transmit Frequency Measurement Test Set Up

4.2.4 Lithium Battery Check

The following paragraphs provide instructions to check the strength of BT1 Lithium Battery, soldered on the A1A1 Interface Printed Wiring Board (PWB) Assembly, as part of scheduled maintenance.

4.2.4.1 Required Equipment

Refer to Table 4-7 for a list of the equipment required to perform the lithium battery check.

Table 4-7. Lithium Battery Check Required Equipment

Reference	Item Name	Part Number	Cage Code	Quantity
1	Digital Multimeter	AN/PSM-45A	89536	1

4.2.4.2 Test Procedure

Perform the following procedure to check the BT1 Lithium Battery:

- a. Remove the A1A1 Interface PWB Assembly from the receiver-transmitter. Refer to Chapter 6, Paragraph 6.5.3.1.
- b. Use the digital multimeter to check the voltage of BT1 Lithium Battery. See Figure 4-4.
- c. If the voltage reading on the digital multimeter is less than +3.00 Vdc, replace the original the A1A1 Interface PWB Assembly with a new A1A1 assembly. Send the original the A1A1 Interface PWB Assembly to the Level IV maintenance facility to have BT1 Lithium Battery replaced.

NOTE

Replacing BT1 Lithium Battery is not an authorized Level III maintenance procedure.

- d. Assemble the receiver-transmitter. Refer to Chapter 6, Paragraph 6.5.3.2.

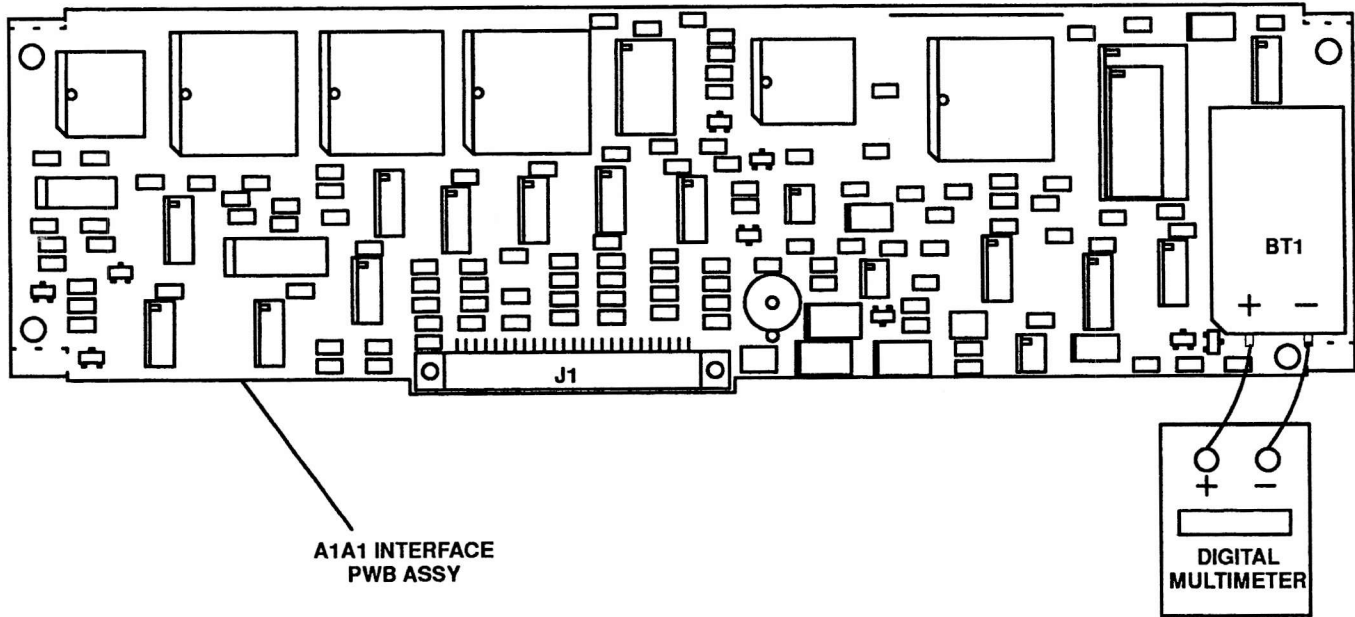

1694-038

Figure 4-4. BT1 Lithium Battery Test Set Up

CHAPTER 5
TROUBLESHOOTING

5.1 INTRODUCTION

5.1.1 General

This chapter provides troubleshooting data necessary for fault isolation to the Shop Replaceable Unit (SRU) level.

5.1.2 Scope of this Chapter

The procedures presented in this chapter assume that the receiver-transmitter is faulty. The maintenance turn-on procedure is used to find a fault indication with the unit. If there is a non-Built-In Test (non-BIT) fault, the maintainer will use the non-BIT troubleshooting procedures. If there is a BIT fault, the maintainer will use the BIT troubleshooting procedure. If the problem is not corrected using these procedures, the troubleshooting index is to be used based on the functional area of the fault. The unit is beyond Level III repair if the faulty circuit cannot be determined by either of these methods. If the problem is found and corrected, the unit is returned to operational readiness. See Figure 5-1.

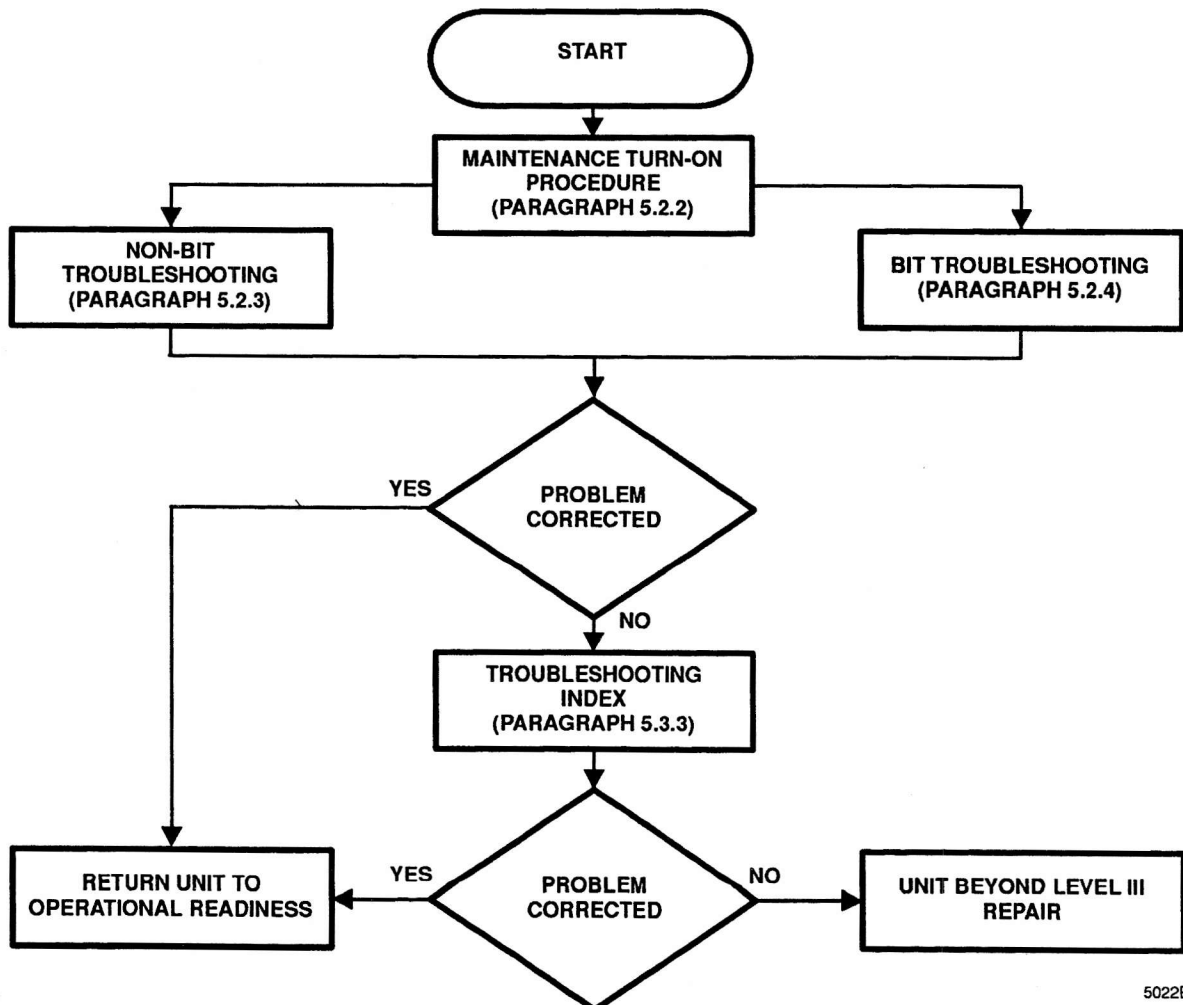

5022E-001

Figure 5-1. Troubleshooting Process Used in this Chapter

5.2 TROUBLESHOOTING PROCEDURES

5.2.1 General

Prior to beginning any troubleshooting procedure, the receiver-transmitter Unit Under Test (UUT) must be installed in a hot test bed setup. Table 5-1 lists the required equipment for the hot test bed. See Figure 5-2 for the equipment interconnect diagram.

Troubleshooting begins with performing the maintenance turn-on procedure. The maintenance turn-on procedure references the non-BIT and BIT troubleshooting procedures. Refer to Paragraph 5.2.2.

Table 5-1. Hot Test Bed Required Equipment

Reference	Item Name	Part Number	Cage Code	Quantity
1	Power Supply	6268B	28480	1
2	Battery Eliminator	10372-9330	14304	1

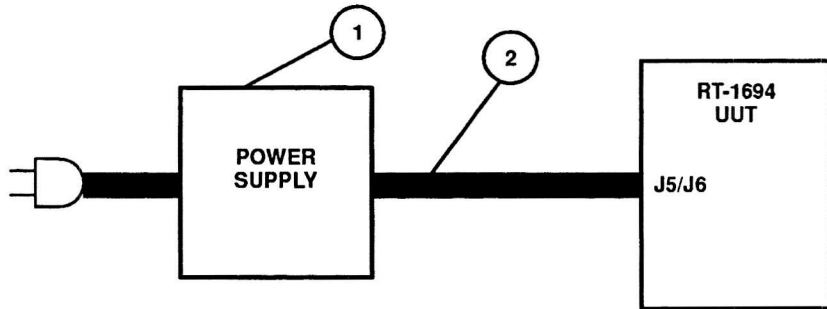

1694-034

Figure 5-2. Hot Test Bed Equipment Interconnect Diagram

5.2.2 Maintenance Turn-On Procedure

Table 5-2 provides the maintenance turn-on procedure for the receiver-transmitter. The maintenance turn-on procedure is used to guide the maintainer through the proper front panel settings to power up the unit from a de-energized state to a fully operational state. In each step, the maintainer is to observe the unit for normal operating conditions. Faults may be observed by BIT or a visual observation. The first column in Table 5-2 contains the procedure. The second column gives the expected normal observation, and the third column references the procedure to follow if the expected normal observation is not found. These references include BIT troubleshooting and non-BIT troubleshooting procedures.

Table 5-2. Maintenance Turn-On Procedure

Step	Observe	Reference
a. Turn the FUNCTION knob on the receiver-transmitter clockwise to the SSB position.	The receiver-transmitter displays the same display from when it was last used in Single Sideband (SSB) mode.	Refer to the non-BIT troubleshooting procedures in Paragraph 5.2.3.
b. Rotate the FUNCTION knob clockwise to the TEST position.	The receiver-transmitter displays an initialization screen, followed by this screen: TEST VERSION VSWR BATTERY	Refer to the non-BIT troubleshooting procedures in Paragraph 5.2.3.
c. Press and release the ENTER key.	The receiver-transmitter displays the following screen: ** SELF TEST ** * IN PROGRESS *	
d. Observe that all tests passed or a fault code is displayed.	If no errors occur during BIT, the receiver-transmitter displays the following screen: SELF TEST DONE ** NO ERRORS ** If a fault code is displayed, note the faulty module or fault group.	Refer to the BIT troubleshooting procedures in Paragraph 5.2.4.

5.2.3 Troubleshooting with Non-Bit Fault Isolation

Table 5-3 is a listing of the non-BIT fault symptoms and a reference to the figure and sheet where the troubleshooting flow begins. On the referenced sheet, follow the top of the diagram from left to right to locate the symptom being experienced. For the applicable symptom, follow from top to bottom for the checks and corrective action. If the actions do not correct the problem, proceed to the troubleshooting index in Paragraph 5.3.3.

Table 5-3. Non-BIT Fault Symptoms

Symptom Observed	Figure/Sheet Reference
Faults that Generate a Message on Receiver-Transmitter Front Panel Liquid Crystal Display (LCD)	
ALE NOT INSTALLED	5-3/1
CHANNEL DATA STORAGE FAILURE	5-3/1
INTERNAL COMM FAULT	5-3/1
OUT OF LOCK	5-3/2
PA COMM FAULT	5-3/2
TUNE FAULT	5-3/2
Miscellaneous Fault Symptoms	
Receiver-transmitter will not tune antenna/high Voltage Standing Wave Ratio (VSWR).	5-3/2
Intermittent/no receive signal; receiver-transmitter still transmits.	5-3/3
Degraded receive audio quality	5-3/4
Degraded transmit signal quality	5-3/5
No transmit or receive	5-3/5
Intermittent transmit output; receiver-transmitter still receives.	5-3/6
No transmit output; receiver-transmitter still receives.	5-3/6
Erroneous transmit or receive data	5-3/7
Receiver-transmitter will not unkey.	5-3/7
Channel selected does not match channel displayed.	5-3/7
Mode selected does not match mode displayed.	5-3/7
Pressing keypad buttons results in data entry errors.	5-3/7
Display does not change when receiver-transmitter is keyed.	5-3/7
No display on front panel LCD	5-3/8
No keypad backlight, or backlight wrong brightness	5-3/8
Automatic Link Establishment (ALE) powers up but does not scan.	5-3/8
ALE scans but does not transmit.	5-3/8
Receiver-transmitter does not synchronize when frequency hopping.	5-3/8
External device does not communicate with receiver-transmitter.	5-3/9
External device does not power up.	5-3/9
Receiver-transmitter does not accept fill data.	5-3/9
Loss of encryption mode	5-3/9

Table 5-3. Non-BIT Fault Symptoms – Continued

Symptom Observed	Figure/Sheet Reference
Receiver-transmitter does not power.	5-3/10
Decreased battery life	5-3/10
Total loss of radio operation	5-3/11
Loss of programmed information	5-3/11
Receiver-transmitter does not come out of standby mode.	5-3/11
Receiver-transmitter does not accept new programming.	5-3/12
Receiver-transmitter displays incorrect battery voltage.	5-3/12
Suspected receive sensitivity problem	5-3/12
Receiver-transmitter failed Receive Sensitivity Test in Chapter 4.	5-3/12
Internal battery charger does not operate.	5-3/13
Suspected power output problem	5-3/13
Receiver-transmitter failed Power Output Test in Chapter 4.	5-3/13
Suspected frequency accuracy problem	5-3/13
Receiver-transmitter failed Transmit Frequency Test in Chapter 4.	5-3/13

5.2.4 Troubleshooting with BIT Fault Isolation

Table 5-4 is a list of BIT fault codes with their suspected faulty assemblies. When a fault code is displayed on the receiver-transmitter front panel, locate the fault code in column one of Table 5-4. Starting with the first assembly listed in column three, remove the assembly and replace it with a spare assembly (refer to Chapter 6 for removal and replacement procedures). Execute BIT. If the unit passes BIT, the faulty module has been isolated. If the unit fails BIT with the same fault code, replace the original module into the receiver-transmitter, and proceed to the next module listed in column three.

Continue in this manner until the fault is eliminated, or all suspected assemblies have been replaced on a trial basis. If all assemblies have been replaced and the unit continues to exhibit the same fault code, refer to Paragraph 5.3.3 and Table 5-6, the Troubleshooting Index, for additional troubleshooting recommendations.

Table 5-4. Receiver-Transmitter Fault Codes and Suspected Assemblies

Fault Code	Description	Suspected Assemblies
A1A1 F01	Communications fault	A4, A1A1
A1A1 F02	Non-destructive internal Random Access Memory (RAM) fault	A1A1
A1A1 F03	Read Only Memory (ROM) checksum fault	A1A1
A1A1 F04	Non-destructive external RAM fault	A1A1
A1A1 F05	Asynchronous data channel fault	A1A1
A1A1 F06	Synchronous data channel fault	A1A1, A10
A1A1 F09	Remote data channel fault	A1A1, A10, A1A2
A1A1 F0A	Dual port RAM semaphore register fault	A6, A1A1
A1A1 F0B	Dual port RAM fault	A1A1, A10
A1A1 F0F	Frame clock not detected	A4, A1A1
A1A1 F10	Power Amplifier (PA) Dual Universal Asynchronous Receiver-Transmitter (DUART) internal counter fault	A1A2, A1A1
A1A1 F11	External PA communications channel fault	A1A2, A1A1
A1A1 F51	Real time clock not installed or not working	A1A1
A1A1 F52	Internal real time clock RAM fault	A1A1
A1A1 F55	Real time clock rollover registers not operational	A1A1
A1A1 F56	Real Time Clock (RTC) crystal oscillator failed	A1A1
A1A1 F81	No communication with encryption board	A1A2, A1A1
A1A2 F81	No communication with interface board	A1A2, A1A1
A1A2 F82	ROM checksum fault	A1A2, A1A1
A1A2 F83	Non-destructive internal RAM fault	A1A2, A1A1
A1A2 F84	Non-destructive external RAM fault	A1A2, A1A1
A1A2 F85	Dual port RAM fault	A1A2, A1A1
A1A2 F86	Dual port RAM semaphore register fault	A1A2
A1A2 F87	Decryption (ACE) chip fault	A1A2, A1A1
A1A2 F88	HSS internal register fault	A1A2, A1A1
A1A2 F89	Encryption/Decryption loop back fault	A1A2, A1A1
A03 F01	8751 communications fault	A3, A11
A03 F02	8751 ROM fault	A3
A03 F03	8751 microprocessor internal RAM fault	A3
A03 F05	8751 dual port RAM fault	A3
A03 F06	8751 dual port RAM busy fault	A3
A03 F07	8751 dual port RAM interrupt fault	A3
A03 F14	Hop clock fault	A4, A3
A03 F15	Frame clock fault	A4, A3
A03 F81	TMS320 internal RAM fault	A3, A4
A03 F82	TMS320 external program RAM fault	A3, A4

Table 5-4. Receiver-Transmitter Fault Codes and Suspected Assemblies – Continued

Fault Code	Description	Suspected Assemblies
A03 F83	TMS320 external data RAM fault	A3, A4
A03 F84	TMS320 ROM fault	A3, A4
A03 F85	TMS320 dual port RAM fault	A3, A4
A03 F86	Sample clock fault	A3, A4
A03 F87	TMS320 AIC fault	A3, A4
A03 F88	TMS320 DAC fault	A3, A4
A03 F5	8751 not finished fault	A3, A4
A03 FA	TMS320 not finished fault	A3, A4
A04 F01	Communication fault (Modem Processors)	A4
A04 F14	Hop clock error (Modem Processors)	A4, A3, A11
A04 F15	Frame clock error (Modem Processors)	A4, A3, A1A1
A04 F1F	Forward Error Correction (FEC) ROM checksum fault (Modem Processors)	A4
A04 F20	FEC external RAM fault (Modem Processors)	A4
A04 F21	FEC dual port RAM fault (Modem Processors)	A4
A04 F22	MDM not running (Modem Processors)	A4
A04 F23	FFT handshake fault (Modem Processors)	A4
A04 F24	FFT to MDM dual port RAM fault (Modem Processors)	A4
A04 F25	MDM to Fast Fourier Transform (FFT) dual port RAM fault (Modem Processors)	A4
A04 F26	MDM to FEC dual port RAM fault (Modem Processors)	A4
A04 F27	MDM ROM checksum fault (Modem Processors)	A4
A04 F28	MDM RAM fault (Modem Processors)	A4
A04 F29	Sample clock error (Modem Processors)	A4
A04 F2A	FFT ROM checksum fault (Modem Processors)	A4
A04 F2B	FFT internal RAM fault (Modem Processors)	A4
A04 F2C	FFT external RAM fault (Modem Processors)	A4
A04 F2D	FFT to DIF dual port RAM fault (Modem Processors)	A4
A04 F2E	Hop clock error (Modem Processors)	A4, A3, A11
A04 F2F	FFT self test not complete (Modem Processors)	A4
A04 F30	FFT self test not complete (Modem Processors)	A4
A04 F31	Reserved (Modem Processors)	A4
A04 F32	Time sample transfer (Modem Processors)	A4
A04 F33	MDM self test not complete (Modem Processors)	A4
A04 F34	FEC self test not complete (Modem Processors)	A4
A04 F41	No communications (Main Control Processor)	A4
A04 F42	Non-destructive internal RAM fault (Main Control Processor)	A4, A5

Table 5-4. Receiver-Transmitter Fault Codes and Suspected Assemblies – Continued

Fault Code	Description	Suspected Assemblies
A04 F43	ROM checksum fault (Main Control Processor)	A4
A04 F44	Non-destructive external RAM fault (Main Control Processor)	A4
A04 F61	Communication fault (Automatic Gain Control [AGC] Processor)	A4
A04 F62	Internal RAM fault (AGC Processor)	A4
A04 F63	ROM checksum fault (AGC Processor)	A4
A04 F64	External RAM fault (AGC Processor)	A4
A04 F67	Digital Intermediate Frequency (IF) handshake fault – dual port RAM (AGC Processor)	A6, A4
A04 F6B	Digital IF not finished with Built-In Test Equipment (BITE) (AGC Processor)	A4
A04 F6C	Anti-alias filter fault (AGC Processor)	A4
A04 F6D	28.8 kHz sampler clock fault (AGC Processor)	A4, A6
A04 F6E	24.0 kHz sampler clock fault (AGC Processor)	A4
A04 F74	Frame clock not detected (AGC Processor)	A4
A04 F75	Hop clock not detected (AGC Processor)	A4
A04 F80	ROM checksum fault (Digital IF Processor)	A4
A04 F81	Internal RAM fault (Digital IF Processor)	A4
A04 F82	External RAM fault (Digital IF Processor)	A4
A04 F83	Dual port RAM to AGC fault (Digital IF Processor)	A4
A04 F84	Dual port RAM to FFT fault (Digital IF Processor)	A4
A05 F01	Receiver in-band analog attenuation too low	A5, A4
A05 F02	Receiver in-band digital attenuation too low	A5, A4
A05 F03	Receiver out-of-band analog attenuation too high	A5, A4
A05 F04	Receiver out-of-band digital attenuation too high	A5, A4
A05 F0F	Exciter gain too low	A5, A4
A05 F10	Exciter gain too high	A5, A4
A05 F11	Exciter output too low	A5, A8
A05 F12	Exciter output too high	A5, A4
A06 F12	Combined lock detect fault	A6, A4, A11
A06 F20	Serial Electrically Erasable Programmable Read Only Memory (EEPROM) data read fault	A6, A4, A11
A08 Faults	Harmonic filter band fault	A8, A9
A08 FFF	All harmonic filter bands failed fault	A8
A09 F01	Coupler – PA path broken	A9, A10, W1
A10 F02	Non-destructive internal RAM fault	A10
A10 F03	ROM checksum fault	A10
A10 F04	Non-destructive external RAM fault	A10
A10 F05	Display driver's busy flag is not functional	A10

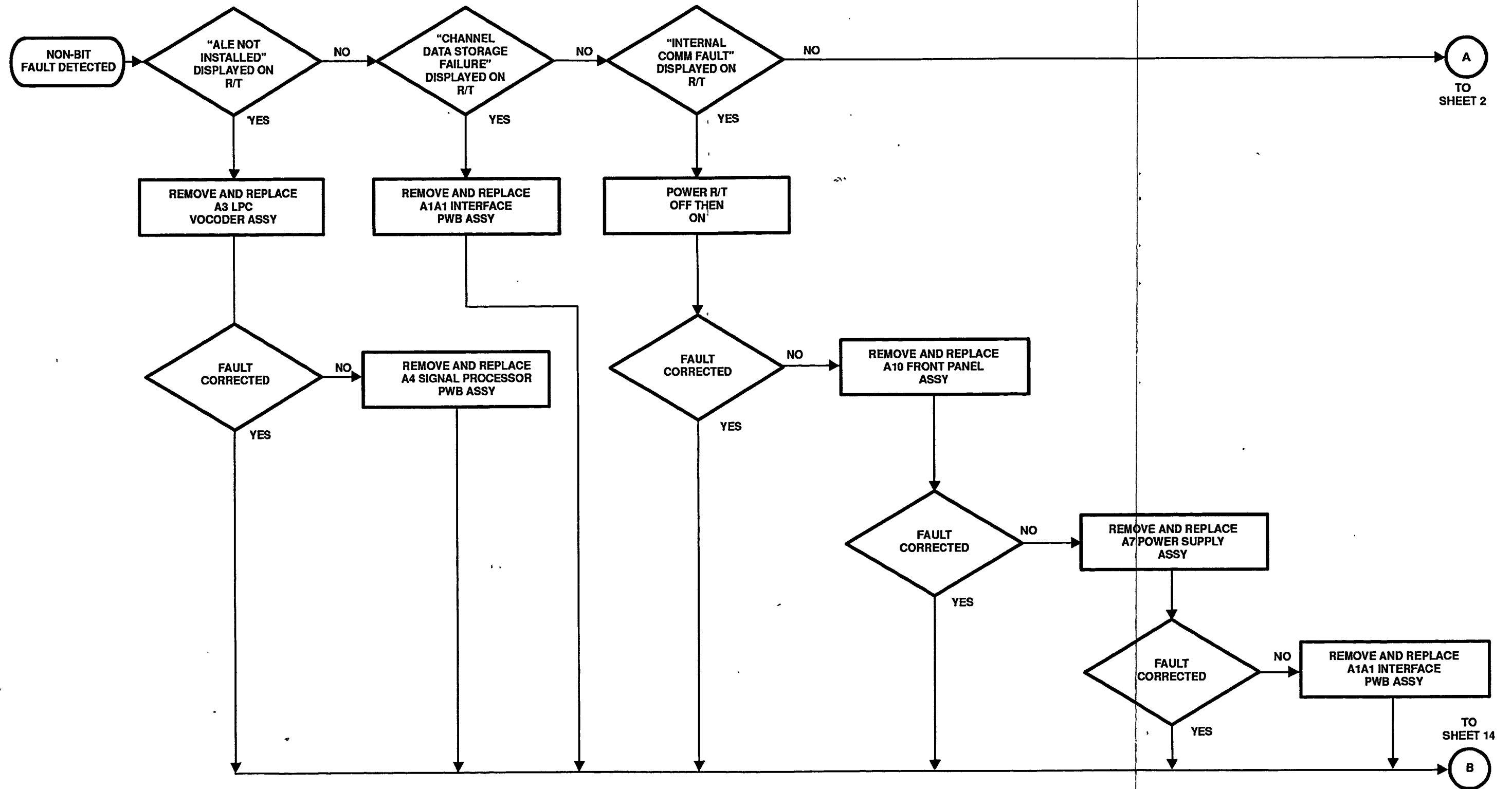

Figure 5-3. Non-BIT Fault Logic Diagram (Sheet 1 of 14)

1694-035
SHEET 1 OF 14

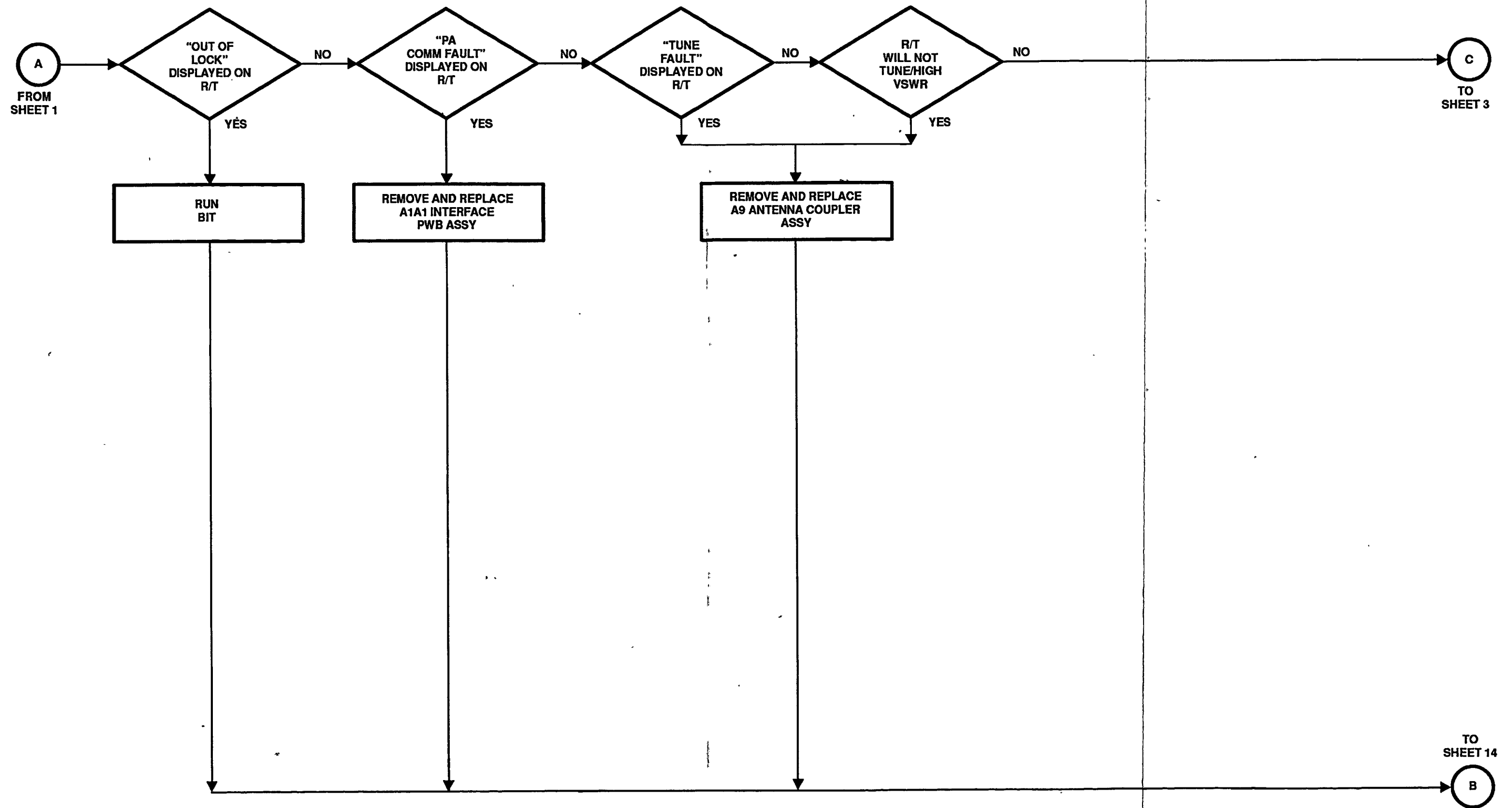

Figure 5-3. Non-BIT Fault Logic Diagram (Sheet 2 of 14)

1694-035
SHEET 2 OF 14

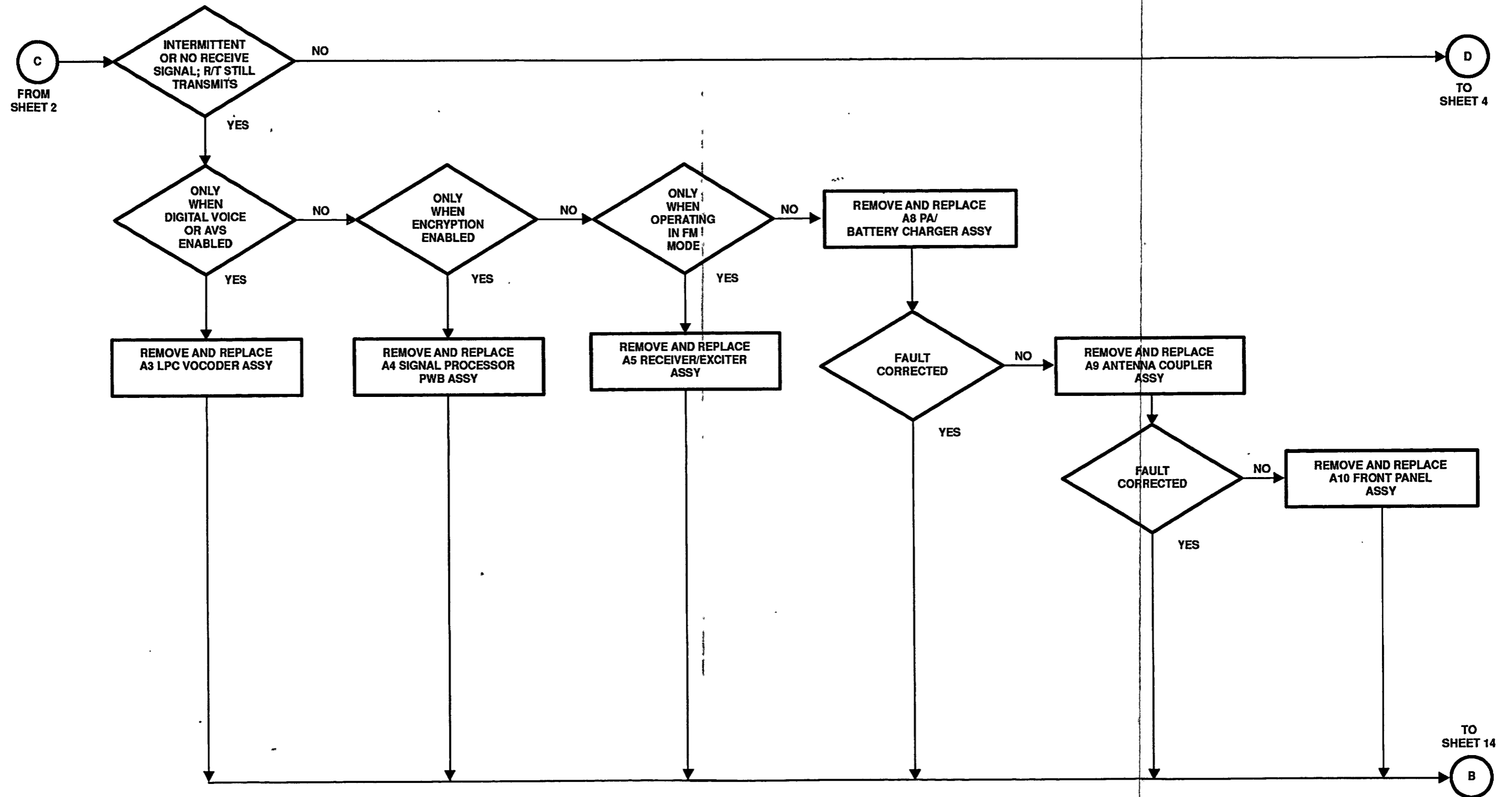
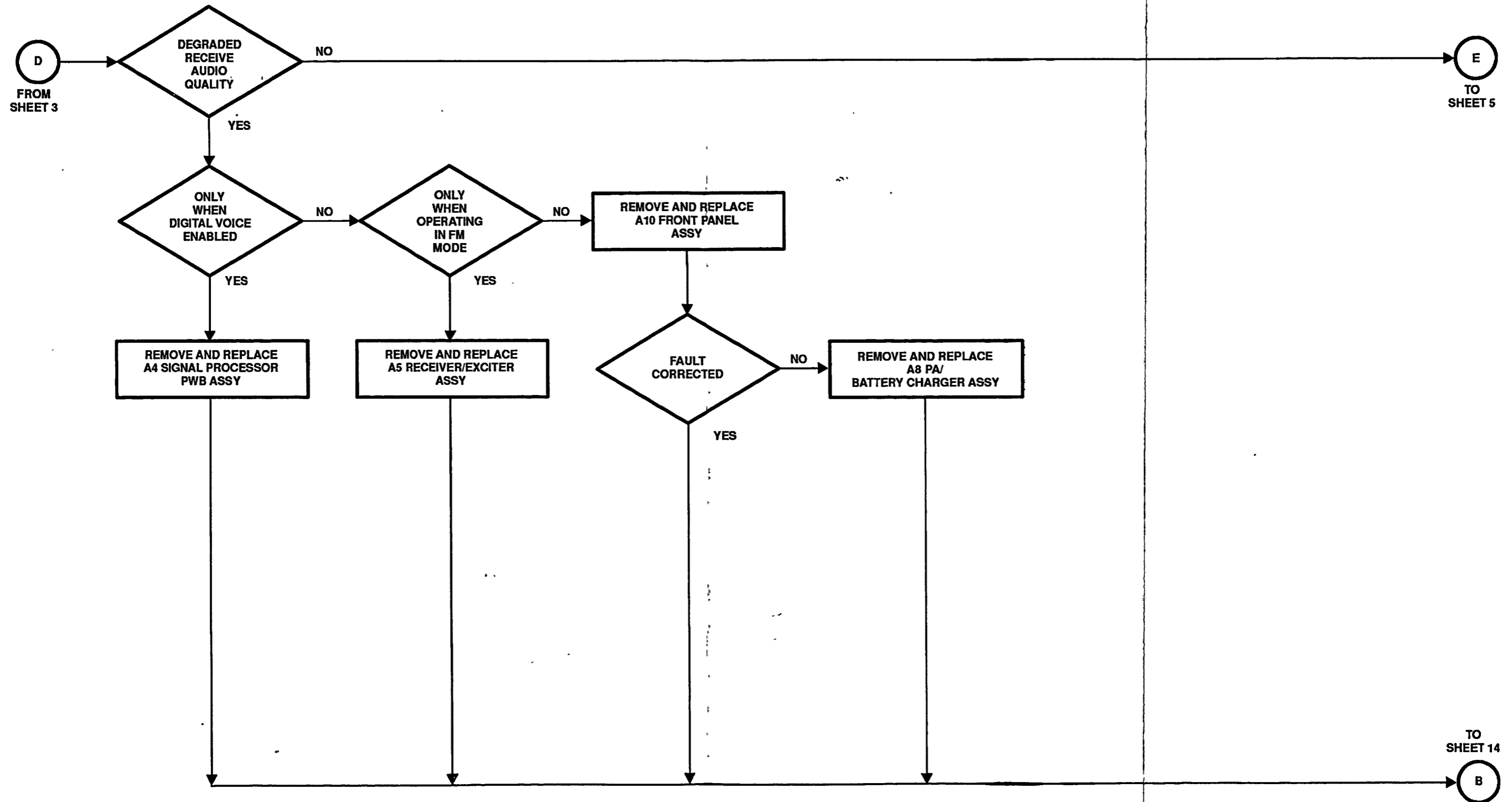

Figure 5-3. Non-BIT Fault Logic Diagram (Sheet 3 of 14)

1694-035
SHEET 3 OF 14



1694-035
SHEET 4 OF 14

Figure 5-3. Non-BIT Fault Logic Diagram (Sheet 4 of 14)

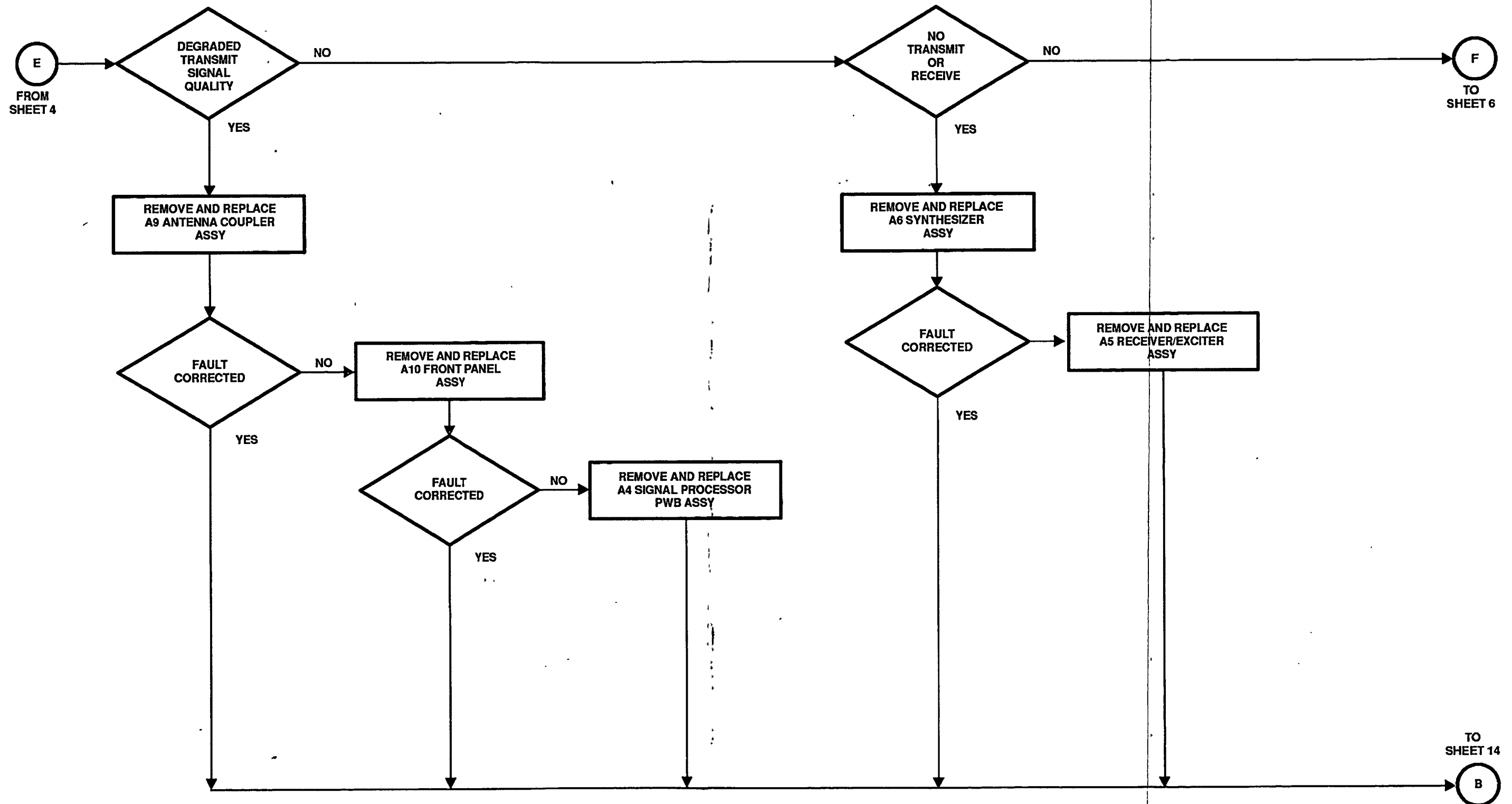

Figure 5-3. Non-BIT Fault Logic Diagram (Sheet 5 of 14)

1694-035
SHEET 5 OF 14

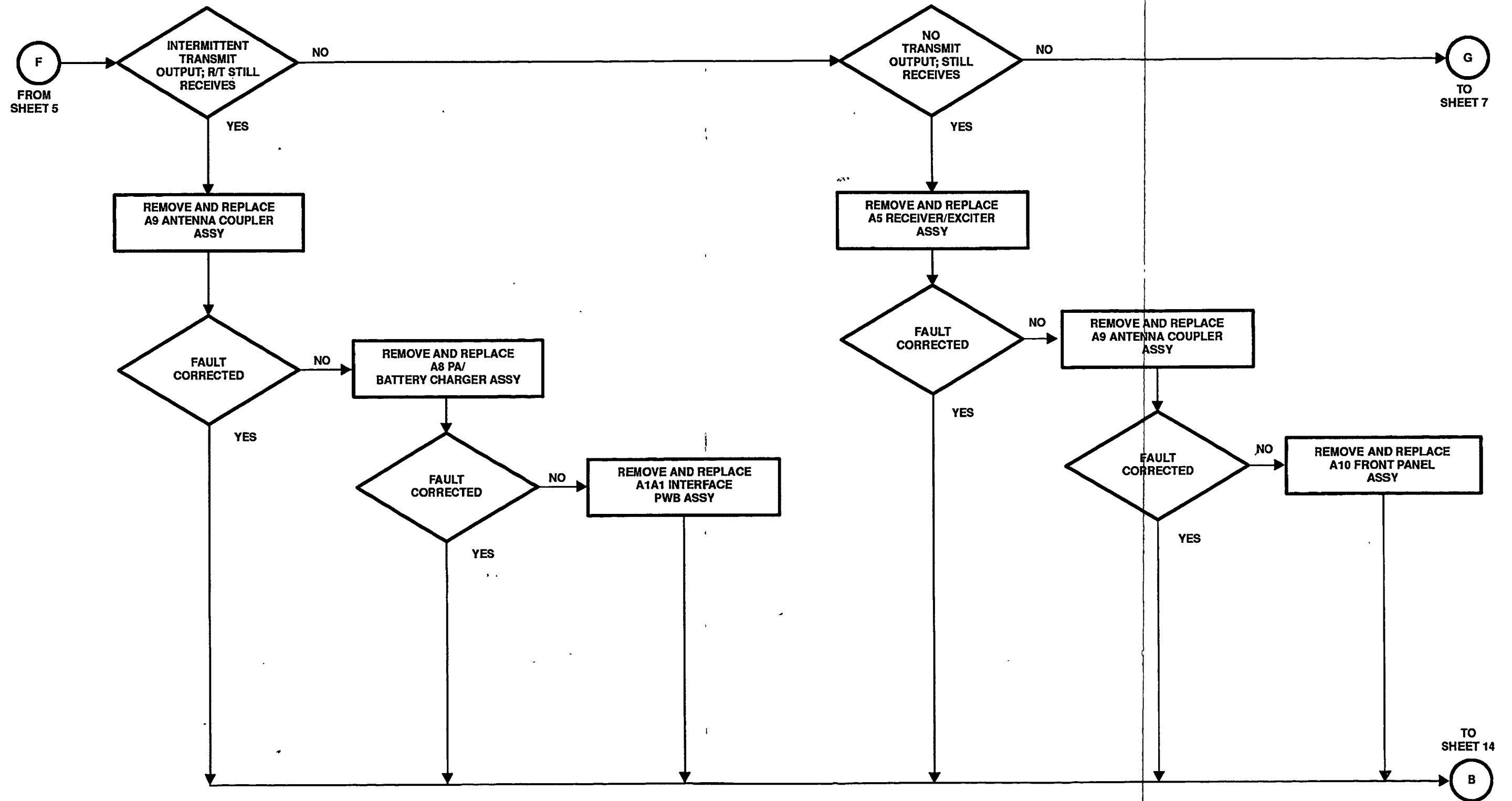

Figure 5-3. Non-BIT Fault Logic Diagram (Sheet 6 of 14)

1694-035
SHEET 6 OF 14

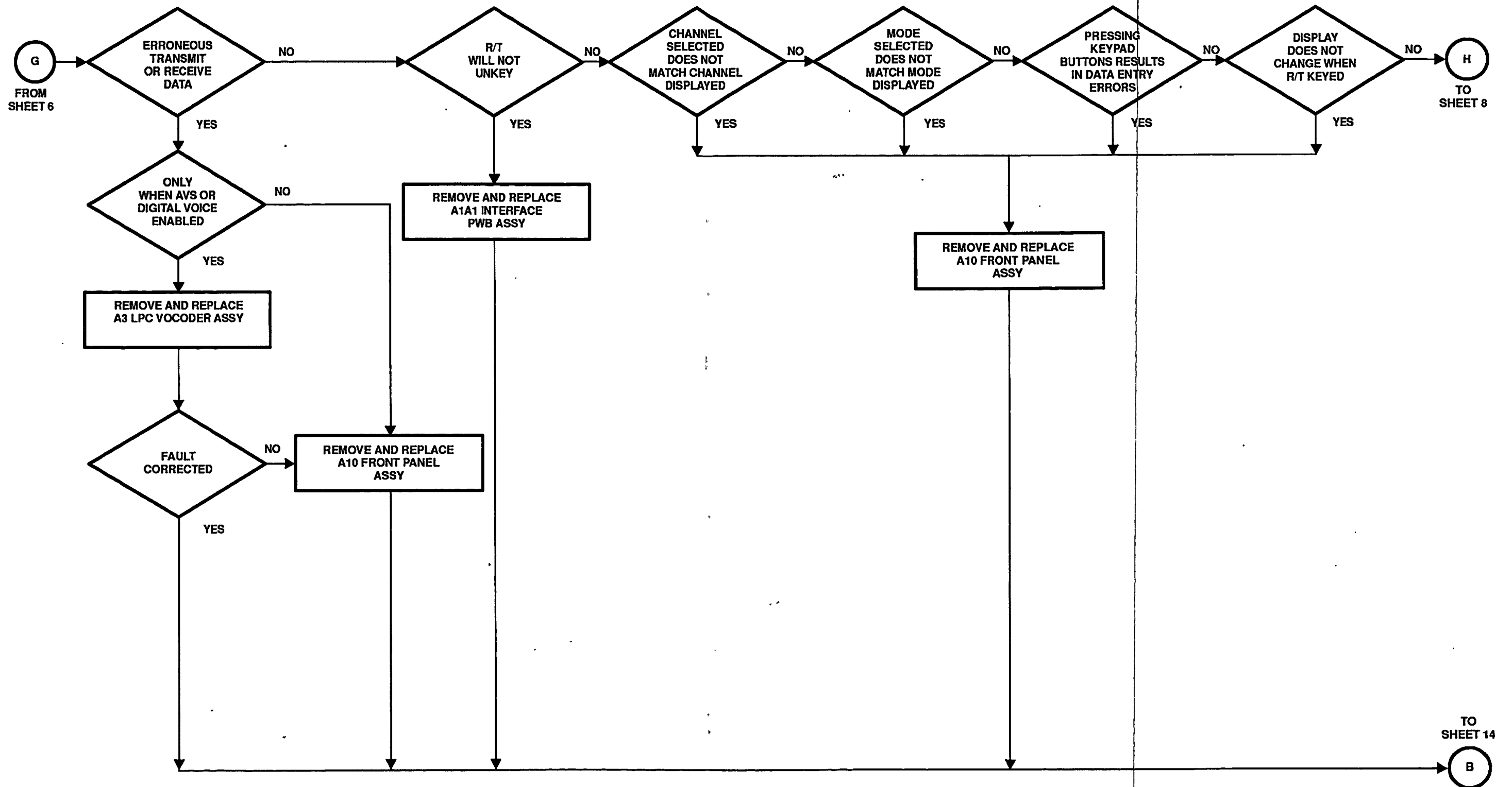

Figure 5-3. Non-BIT Fault Logic Diagram (Sheet 7 of 14)

1694-035
SHEET 7 OF 14

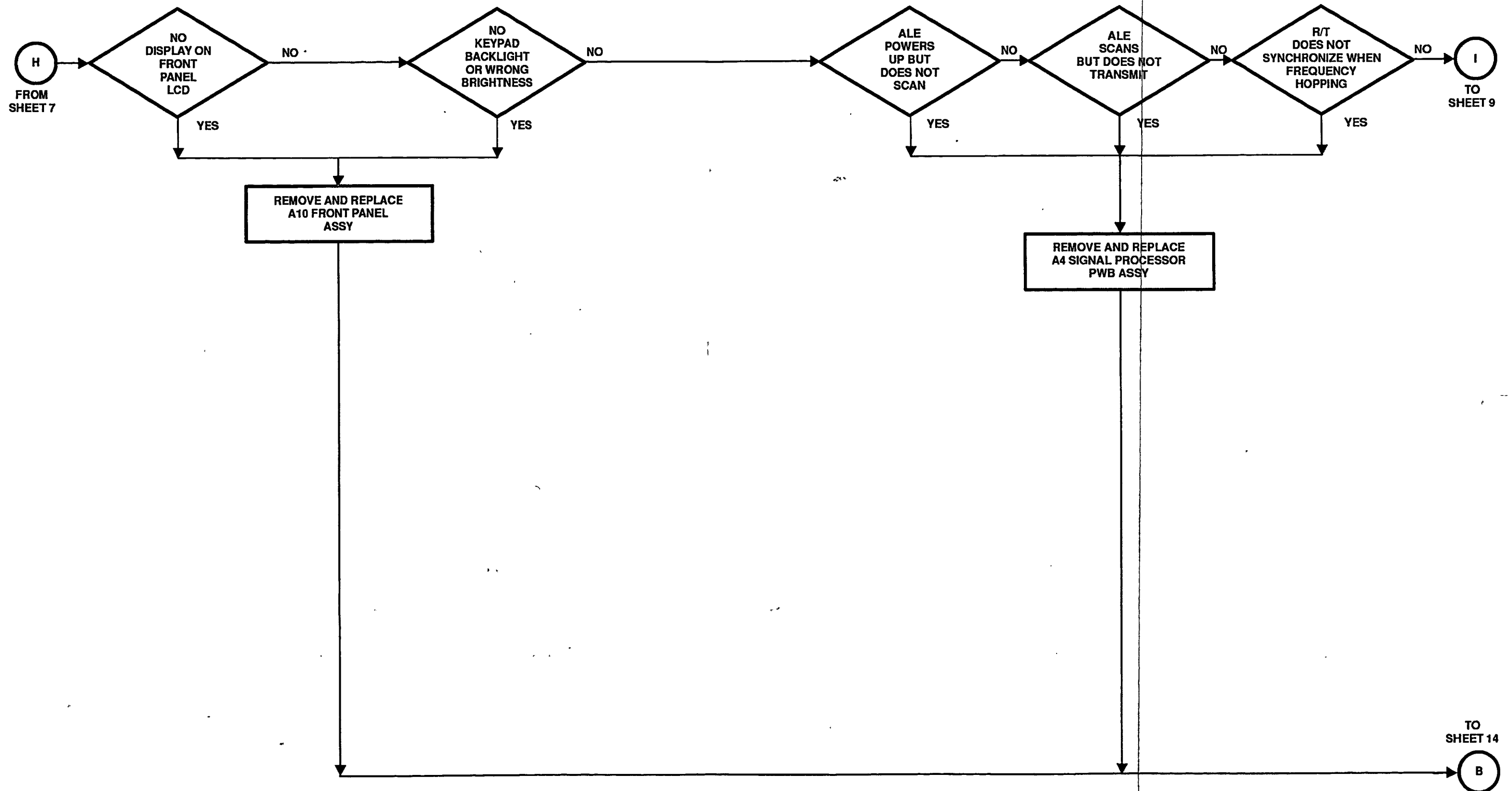

Figure 5-3. Non-BIT Fault Logic Diagram (Sheet 8 of 14)

1694-035
SHEET 8 OF 14

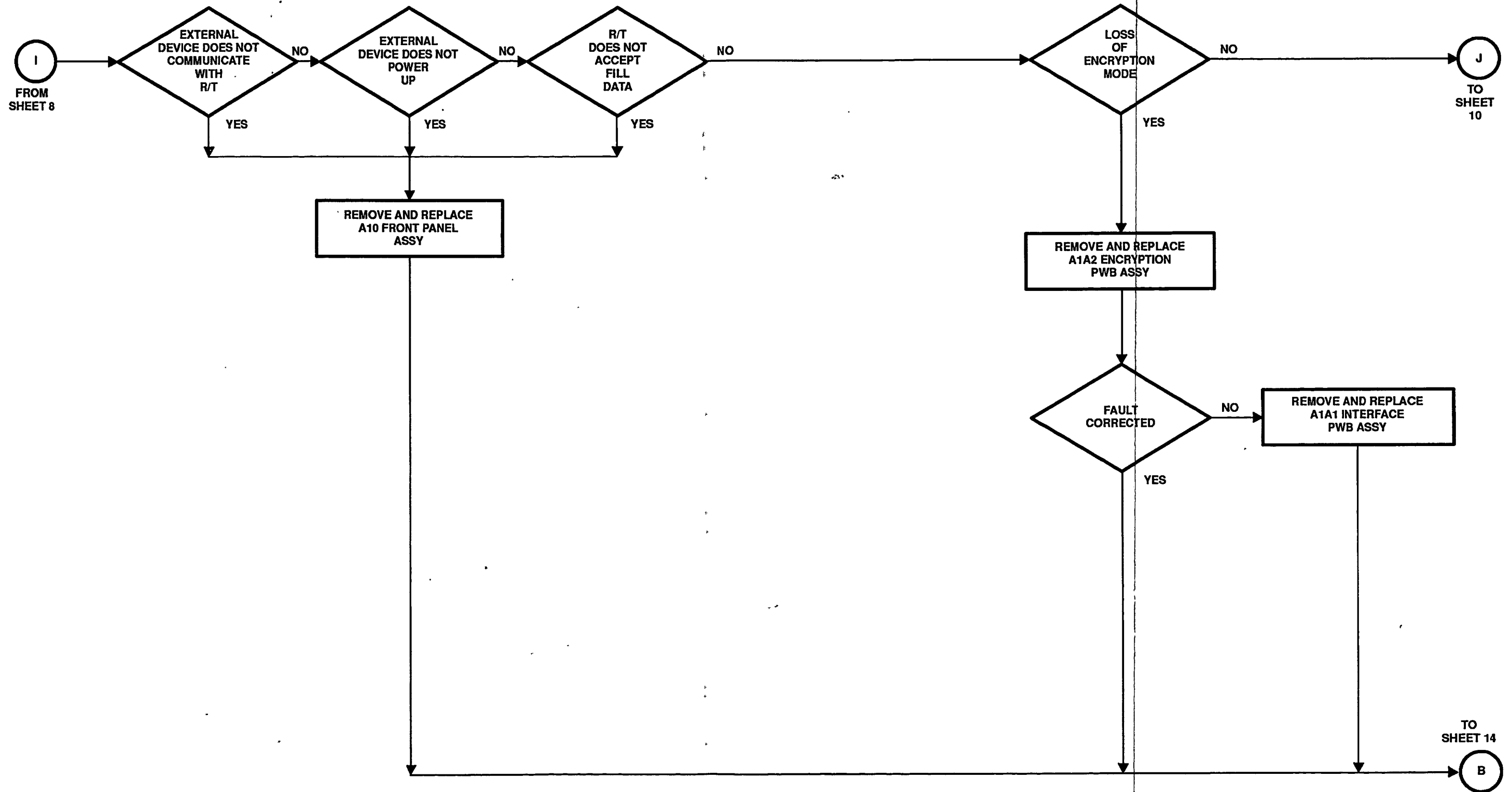

Figure 5-3. Non-BIT Fault Logic Diagram (Sheet 9 of 14)

1694-035
SHEET 9 OF 14

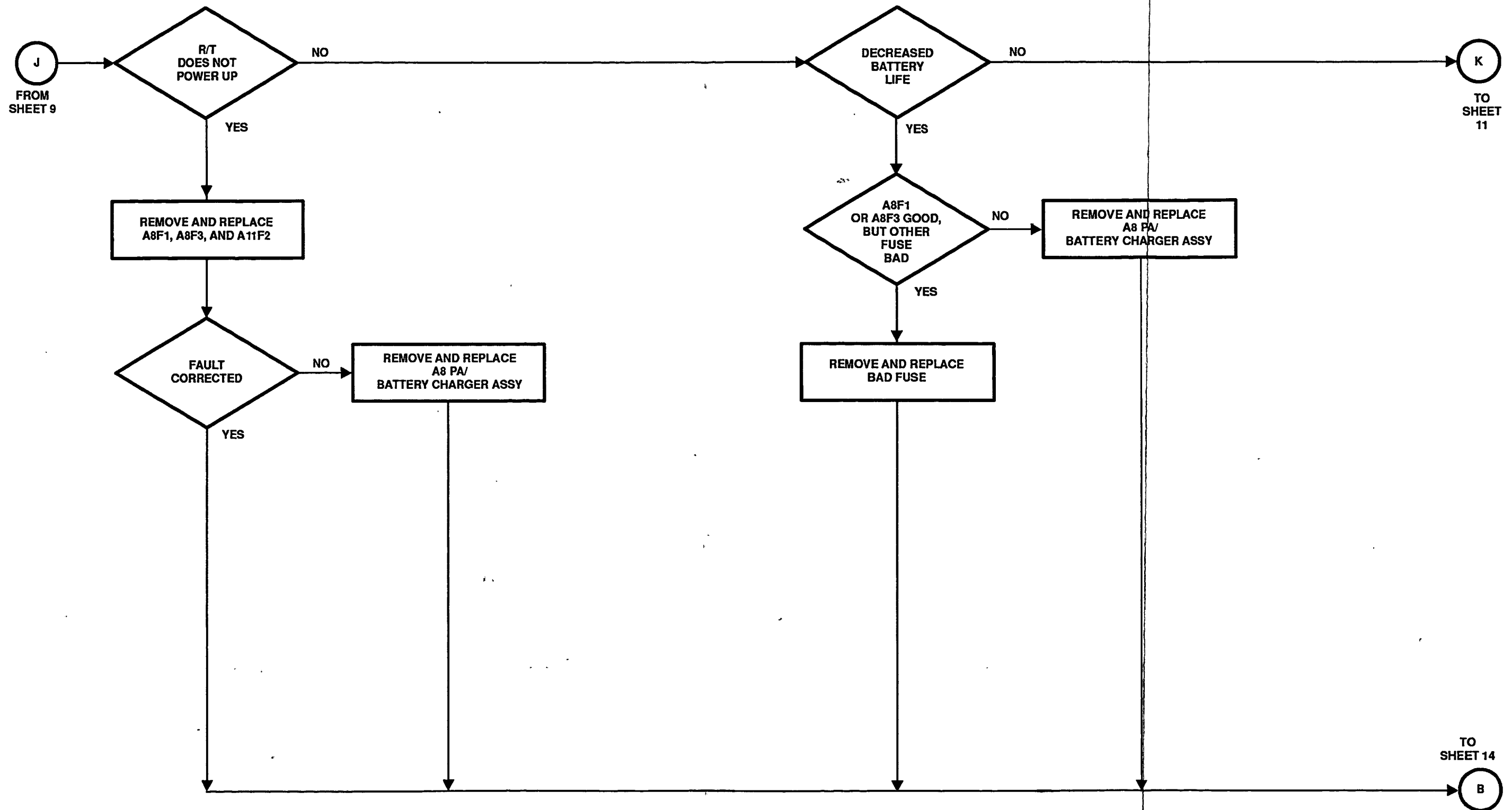

Figure 5-3. Non-BIT Fault Logic Diagram (Sheet 10 of 14)

1694-035
SHEET 10 OF 14

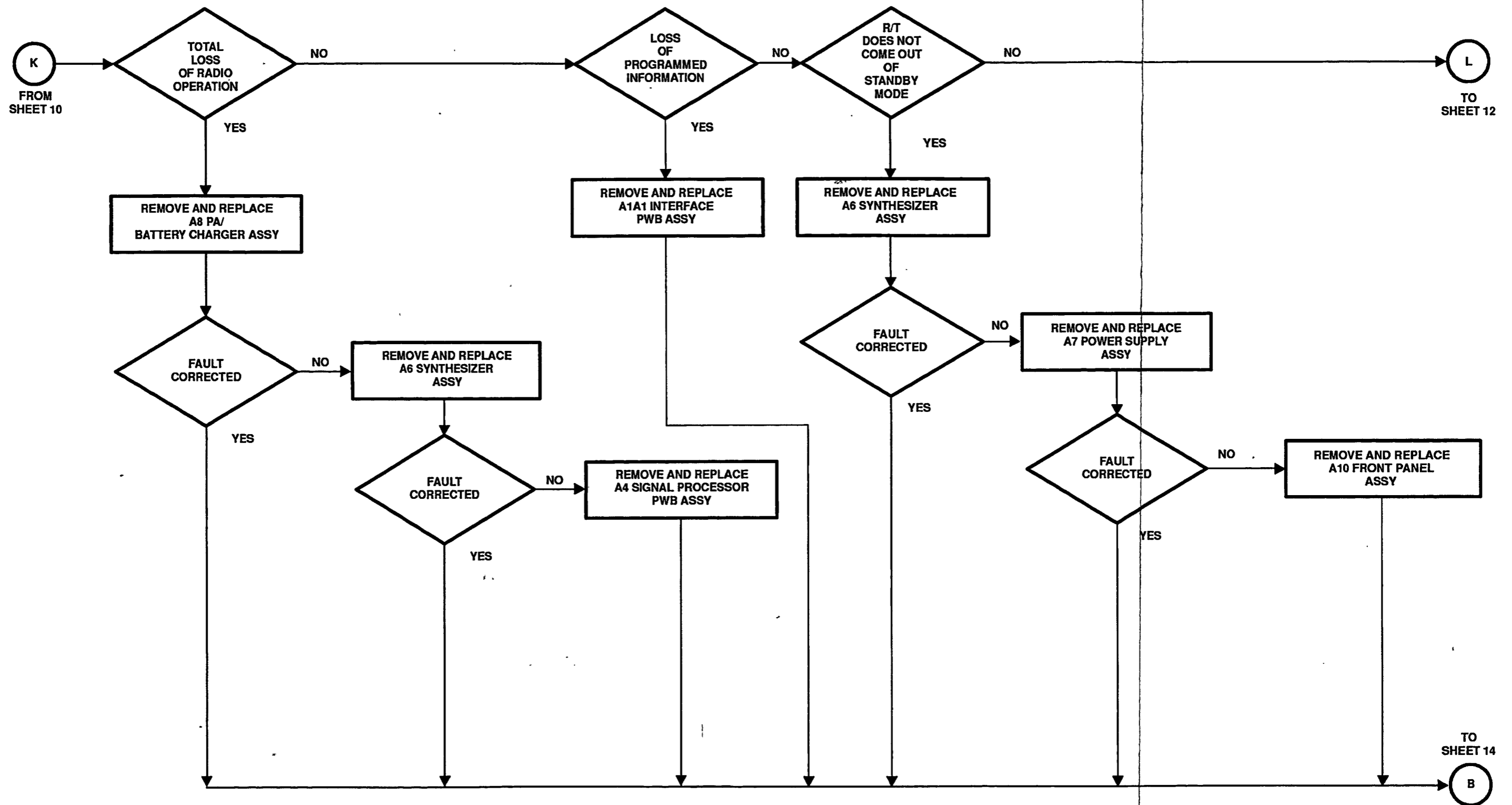

Figure 5-3. Non-BIT Fault Logic Diagram (Sheet 11 of 14)

1694-035
SHEET 11 OF 14

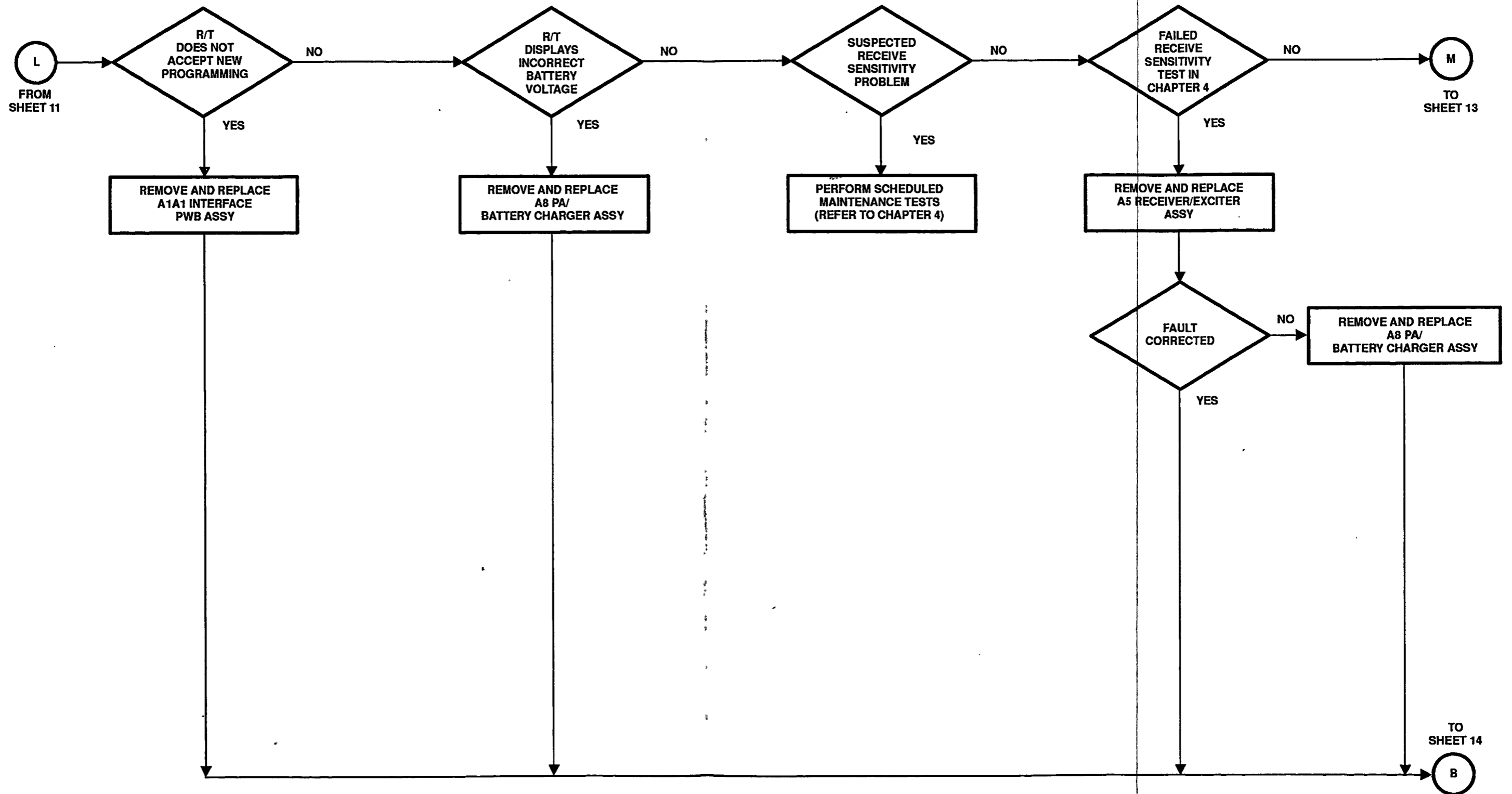
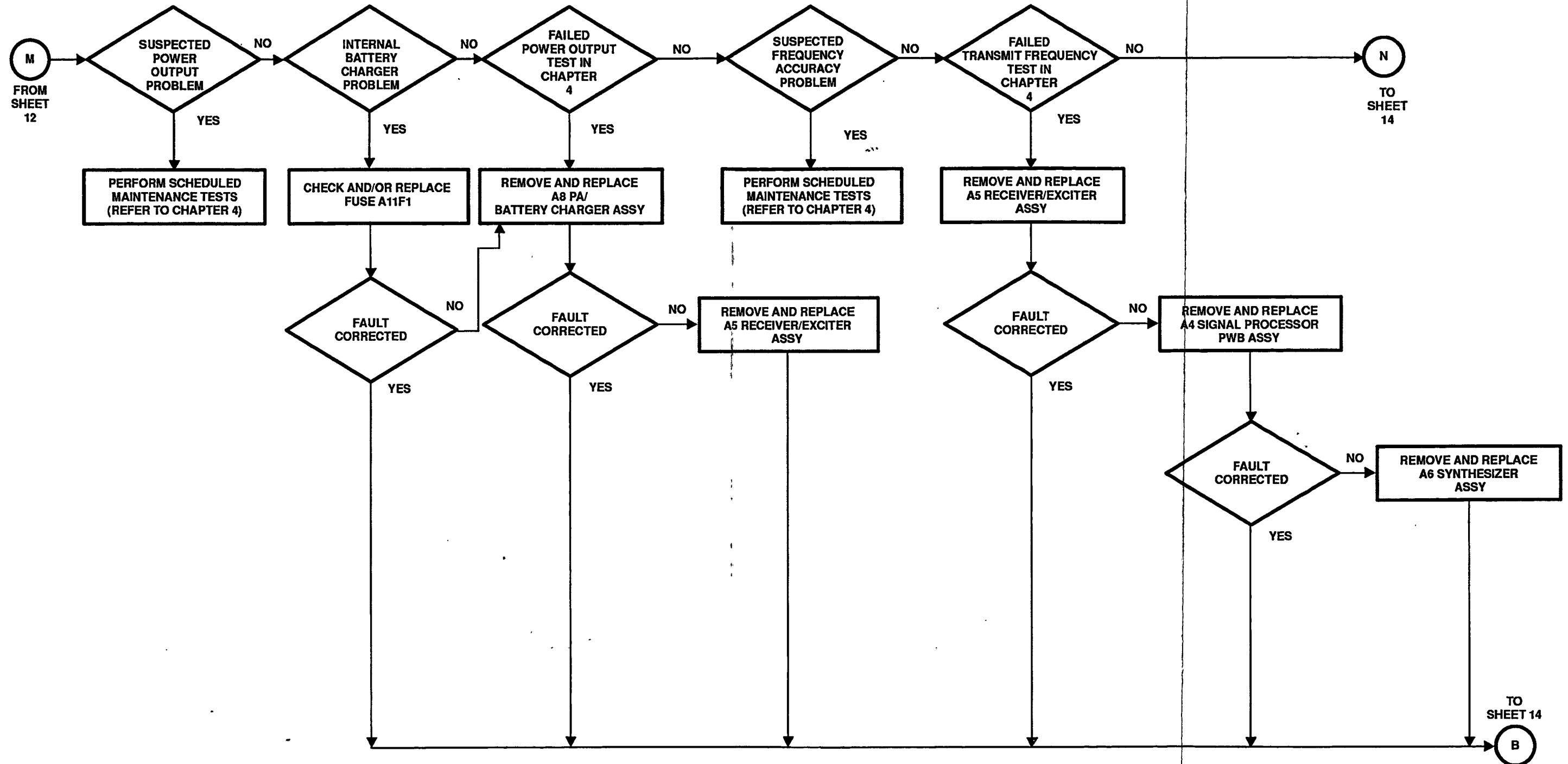

Figure 5-3. Non-BIT Fault Logic Diagram (Sheet 12 of 14)

1694-035
SHEET 12 OF 14



1694-035
SHEET 13 OF 14

Figure 5-3. Non-BIT Fault Logic Diagram (Sheet 13 of 14)

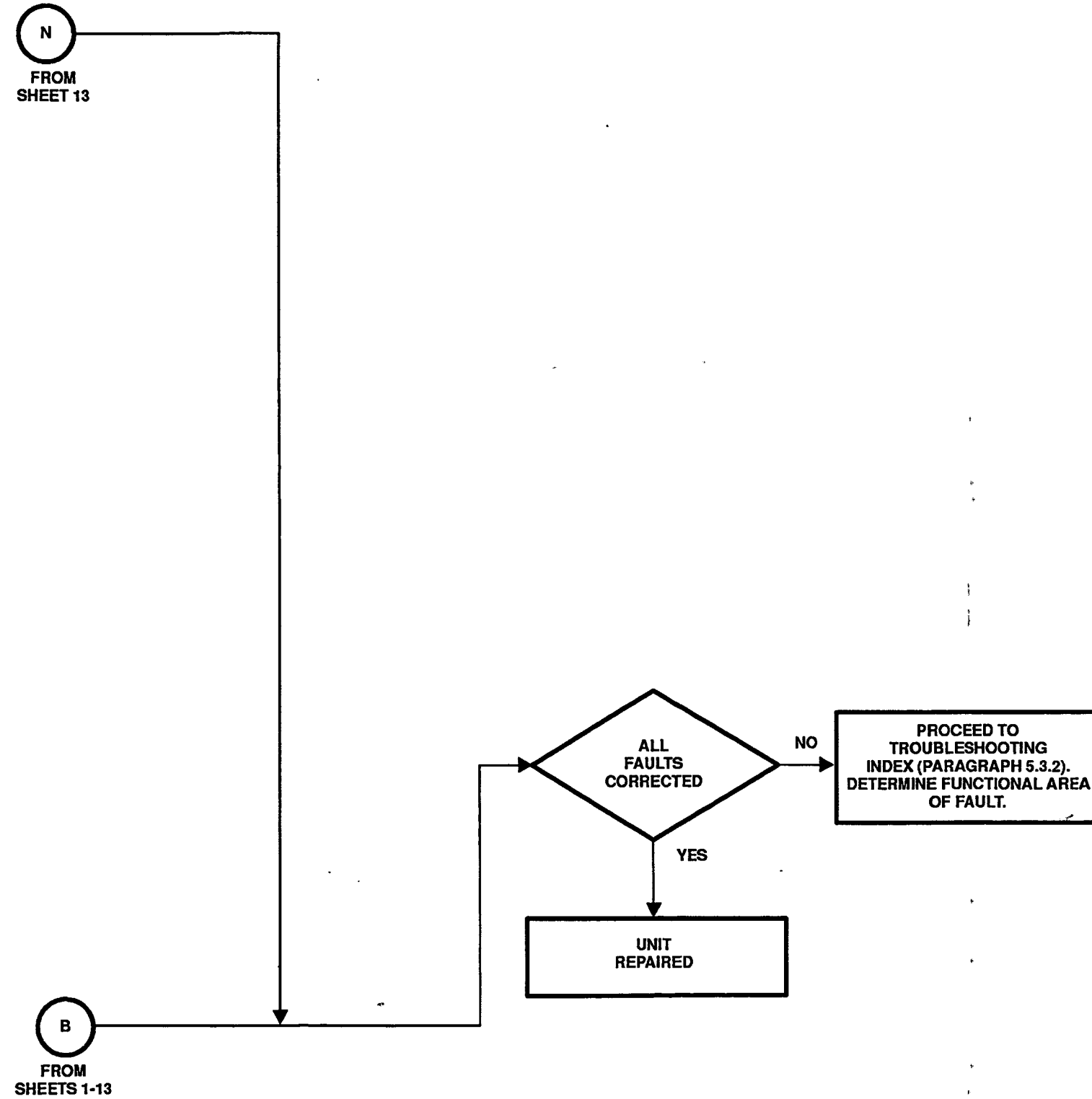

Figure 5-3. Non-BIT Fault Logic Diagram (Sheet 14 of 14)

5.3 TROUBLESHOOTING SUPPORT DATA

5.3.1 Protective Device Index

Table 5-5 is the protective device index. The Direct Current (DC) input from the batteries to the receiver-transmitter is protected by A8F1 and A8F3, mounted on the A8A1 PA/Battery Charger PWB Assembly. For information on how to remove and replace these fuses, refer to Paragraph 6.5.9.1.

Table 5-5. Protective Device Index

Reference Designation	Panel Marking or ID	Rating		Circuit Protected	Diag. Ref.
		Volts	Amps		
A8F1	N/A	125	7	Entire Unit	6-10
A8F3	N/A	125	7	Entire Unit	6-10
A11F1	N/A	125	7	Entire Unit	6-13
A11F2	N/A	125	2	Entire Unit	6-13

5.3.2 Relay and Lamp Indexes

Since there are no maintainer-replaceable relays or lamps in the receiver-transmitter, relay and lamp indexes are not provided.

5.3.3 Troubleshooting Index

Table 5-6 is the troubleshooting index for the receiver-transmitter. Use the troubleshooting index if the actions called out in the non-BIT (Paragraph 5.2.3) or BIT troubleshooting (Paragraph 5.2.4) procedures do not correct a problem. The functional areas are listed in the left column of the index in Table 5-6. The second column references the functional block diagrams for each functional area. A reference for the text description for each functional area is provided in column three. Column four is not applicable to the receiver-transmitter. Analyze the information for each functional area and the interconnect schematic diagram (see Figure 5-6), and determine which circuits affect each functional area in an attempt to isolate the problem to an SRU.

The information contained in this manual complies with the requirements specified for Level III maintenance. If the unit or component is still non-functional after using the procedures, functional descriptions, and block diagrams in this manual, refer to local directives for disposition of the unit.

Table 5-6. Troubleshooting Index

Functional Area	Signal Path Diagram	Functional Description Paragraph	Alignment/Adjustment Paragraph
BIT Signal Path	N/A	5.6	N/A
RF/IF/Audio/Digital/Control Signal Path	5-4	3.3.2 3.3.3	N/A
Power Distribution	5-5	3.3.11	N/A

5.4 TROUBLESHOOTING DIAGRAMS

5.4.1 General

Troubleshooting diagrams are described in their respective paragraphs, and include the following:

- RF/IF/Audio/Data/Control Signal Path Diagram
- Power Distribution Diagram

5.4.2 BIT Signal Path Diagram

Because much of the BIT detection occurs over the High Speed Serial Bus (HSSB), there is no BIT signal path diagram. Refer to Paragraph 5.2.4 for BIT troubleshooting recommendations. Refer to Paragraph 5.6 for BIT test descriptions.

5.4.3 RF/IF/Audio/Digital/Control Signal Path Diagram

See Figure 5-4 for the RF/IF/audio/digital/control signal path diagram. This diagram show circuits that are used for the RF, IF, audio, digital, and control signals.

5.4.4 Power Distribution Diagram

See Figure 5-5 for the power distribution diagram. This diagram shows the paths of the power supply DC voltages.

5.5 INTERCONNECT SCHEMATIC DIAGRAM

5.5.1 General

Figure 5-6 is the interconnect schematic diagram for the receiver-transmitter.

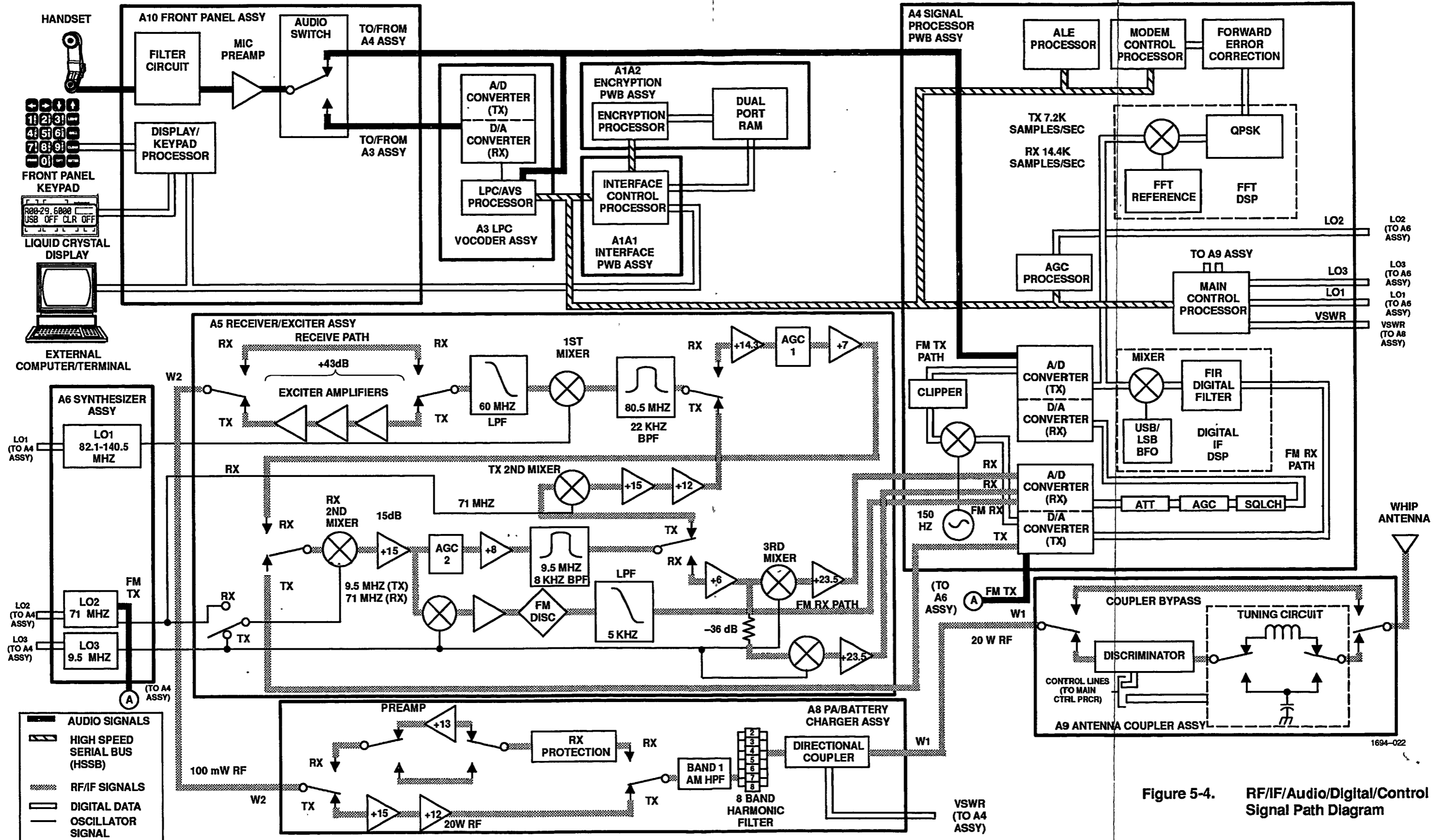
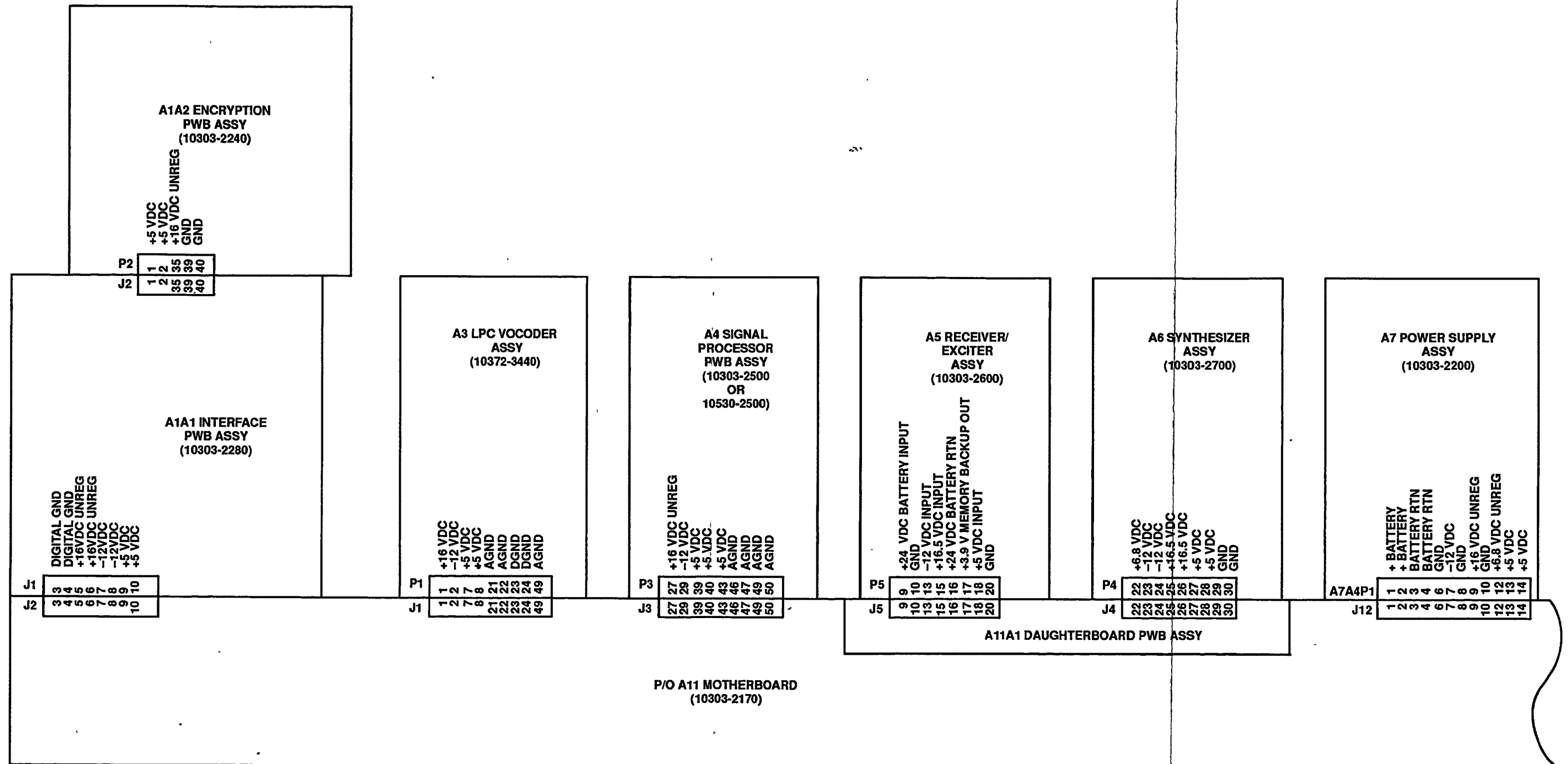

Figure 5-4. RF/IF/Audio/Digital/Control Signal Path Diagram

1694-022



1694-036(A)
SHEET 1 OF 2

Figure 5-5. Power Distribution Diagram
(Sheet 1 of 2)

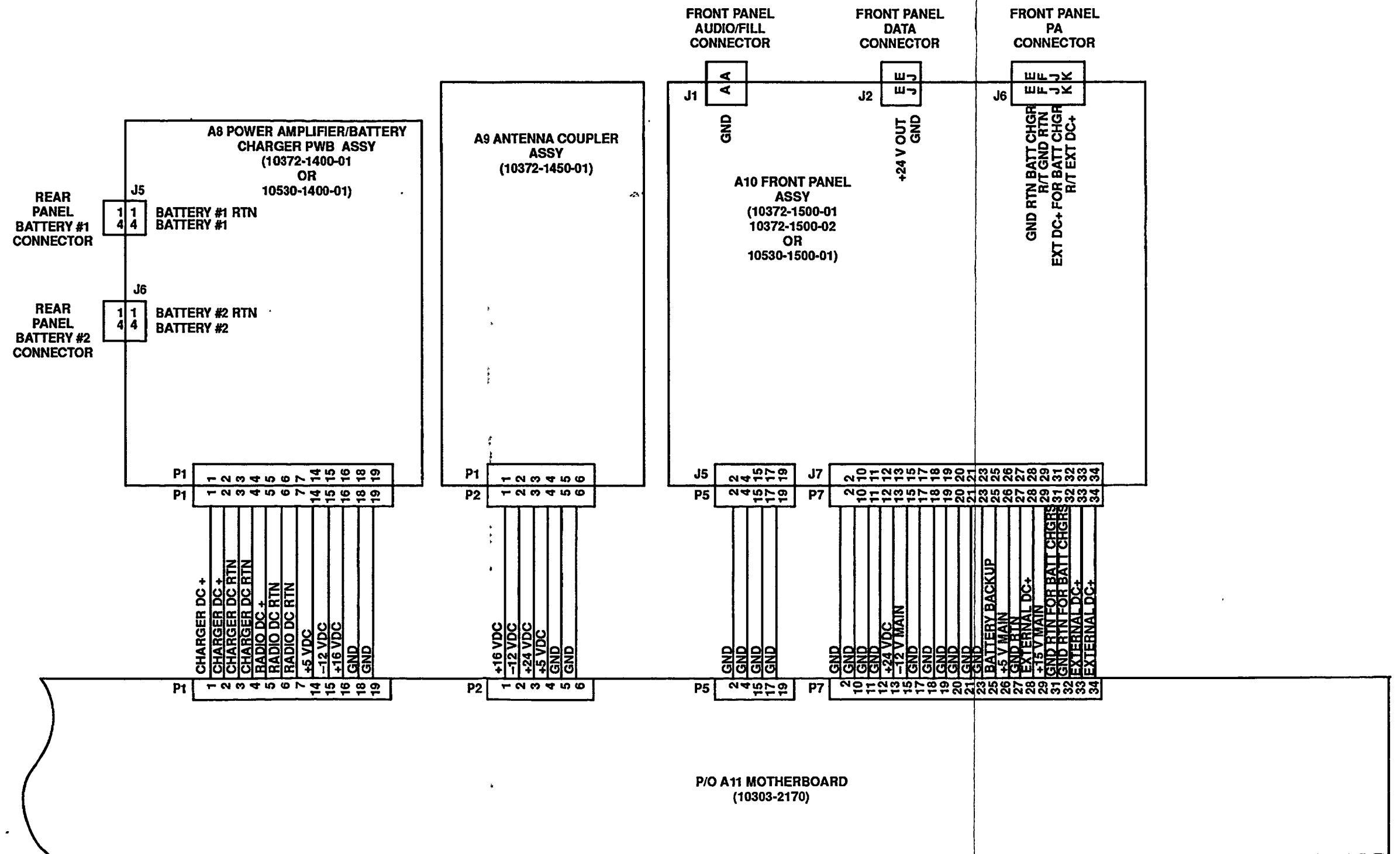

1694-036(A)
SHEET 2 OF 2

Figure 5-5. Power Distribution Diagram (Sheet 2 of 2)

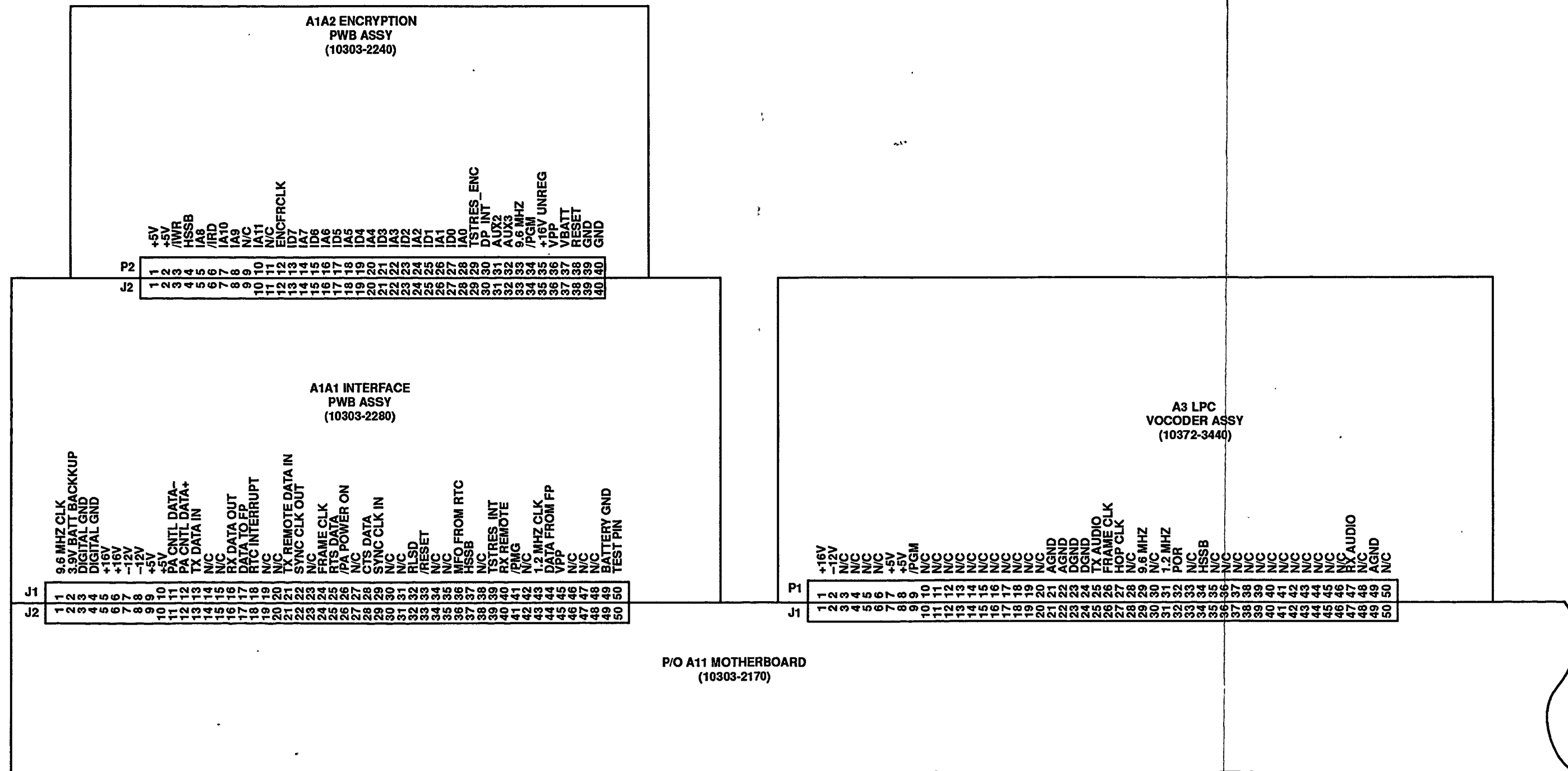

1694-037(A)
SHEET 1 OF 6

Figure 5-6. Receiver-Transmitter Interconnect Schematic Diagram (Sheet 1 of 6)

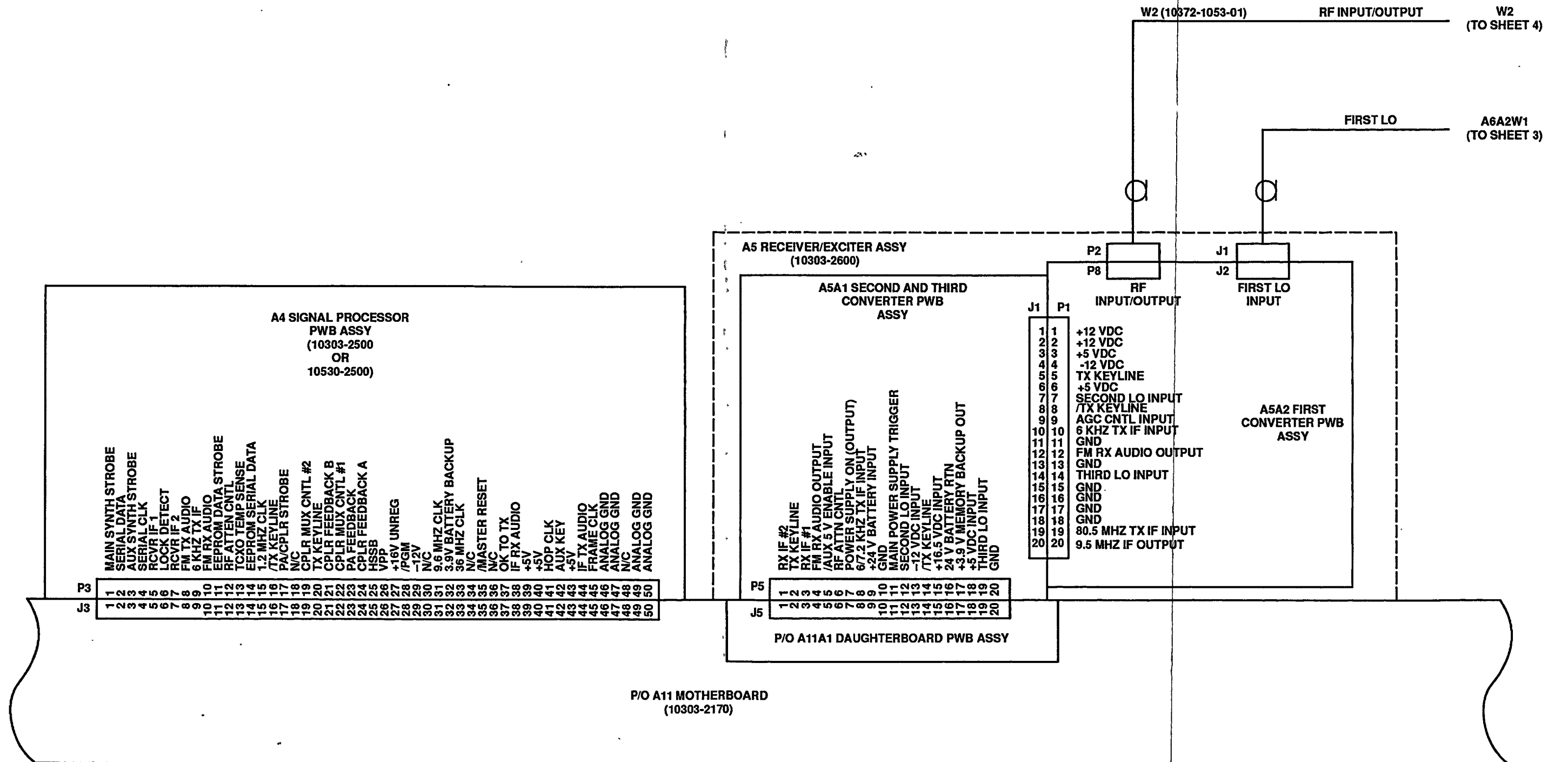

1694-037(A)
SHEET 2 OF 6

Figure 5-6. Receiver-Transmitter Interconnect Schematic Diagram (Sheet 2 of 6)

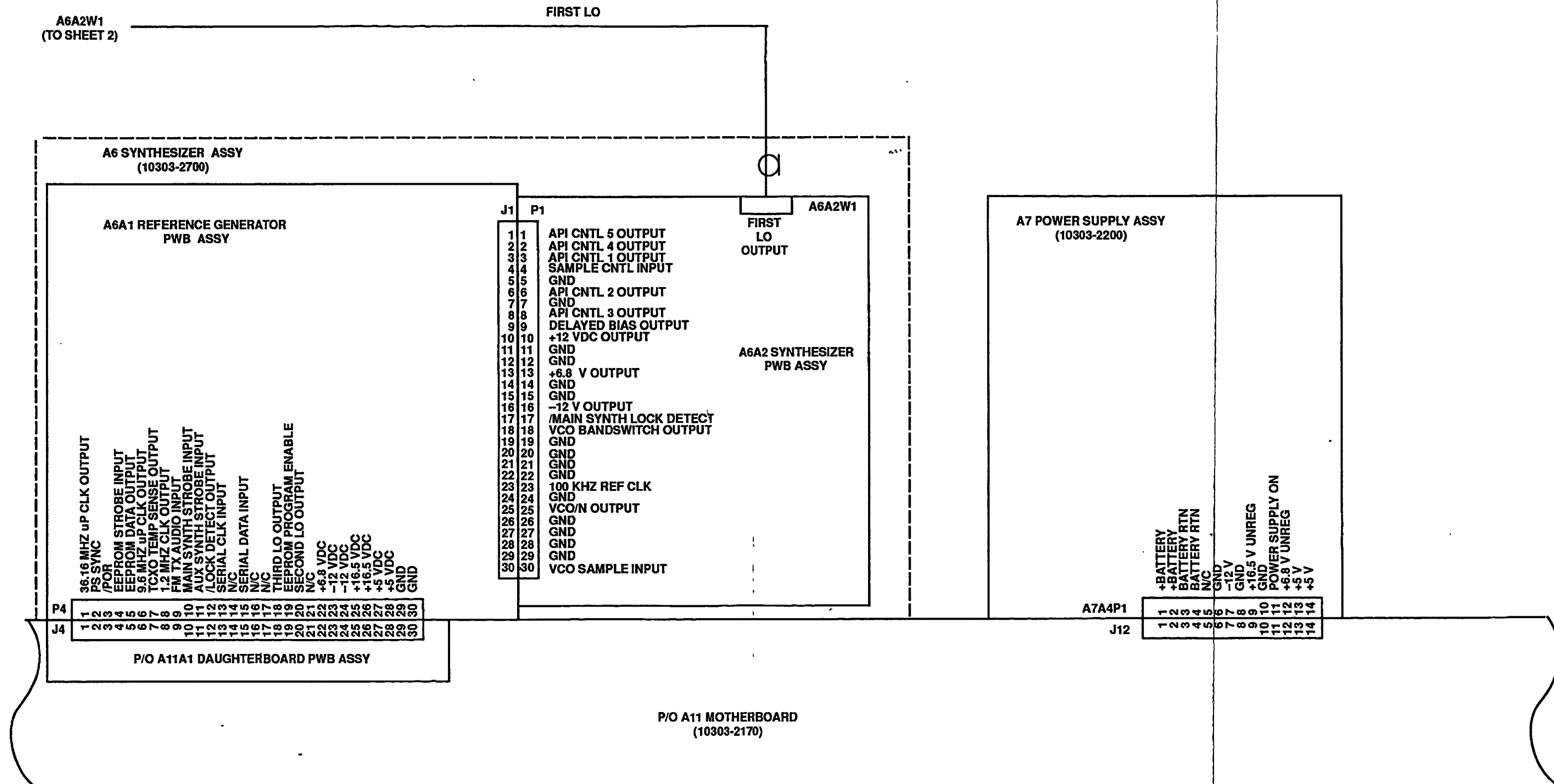

1694-037(A)
SHEET 3 OF 6

Figure 5-6. Receiver-Transmitter Interconnect Schematic Diagram (Sheet 3 of 6)

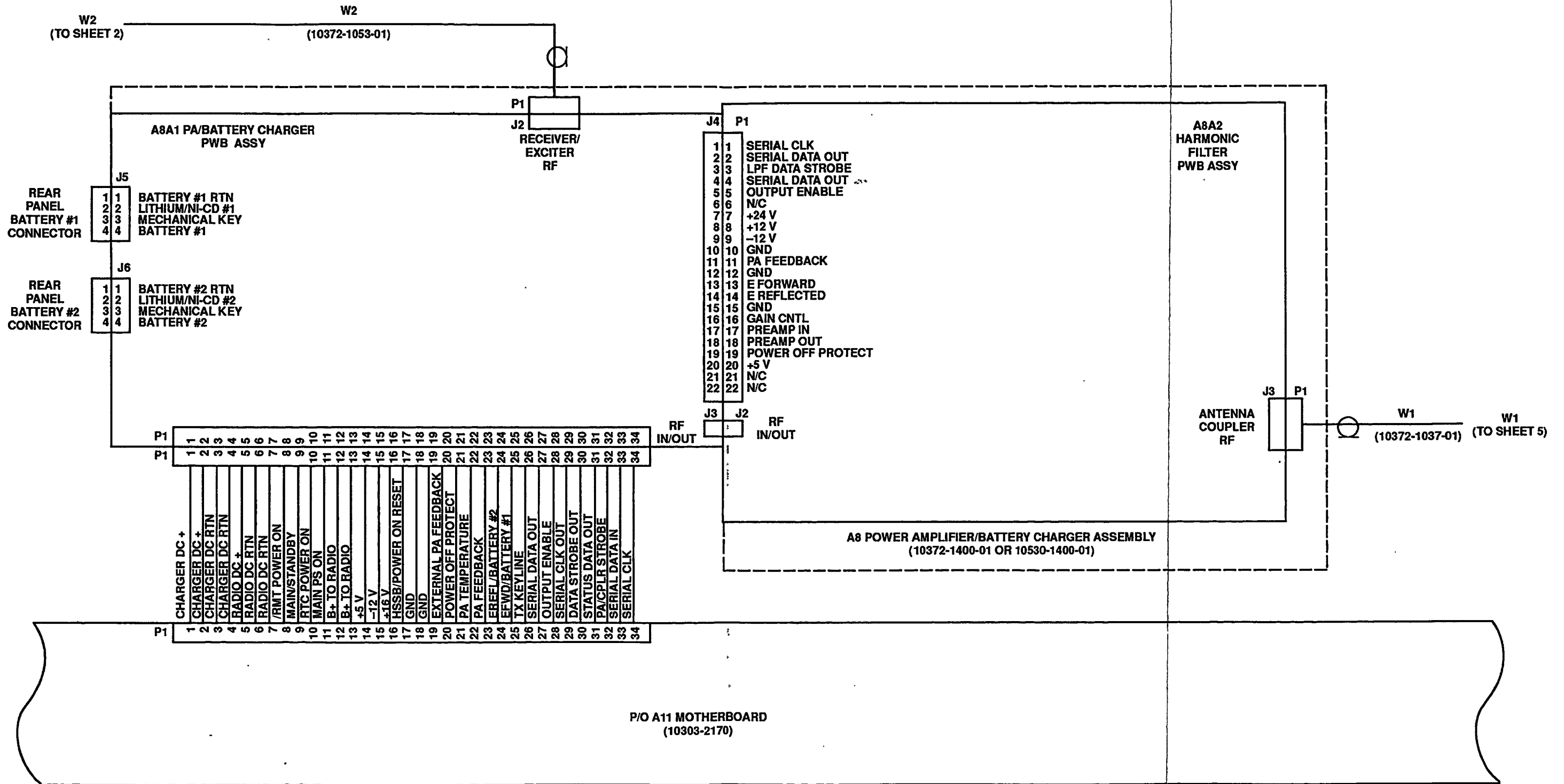

1694-037(A)
SHEET 4 OF 6

Figure 5-6. Receiver-Transmitter Interconnect Schematic Diagram (Sheet 4 of 6)

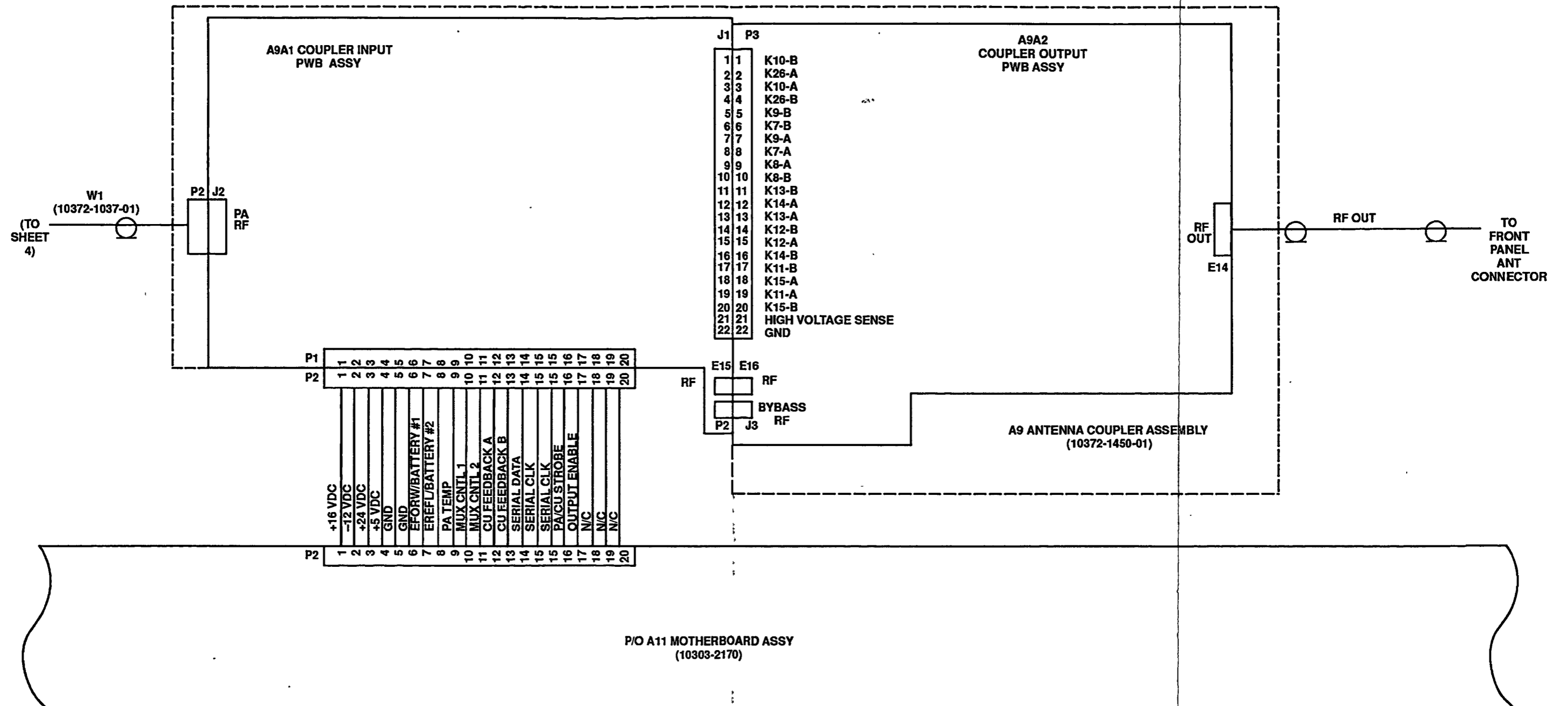

1694-037(A)
SHEET 5 OF 6

Figure 5-6. Receiver-Transmitter Interconnect Schematic Diagram (Sheet 5 of 6)

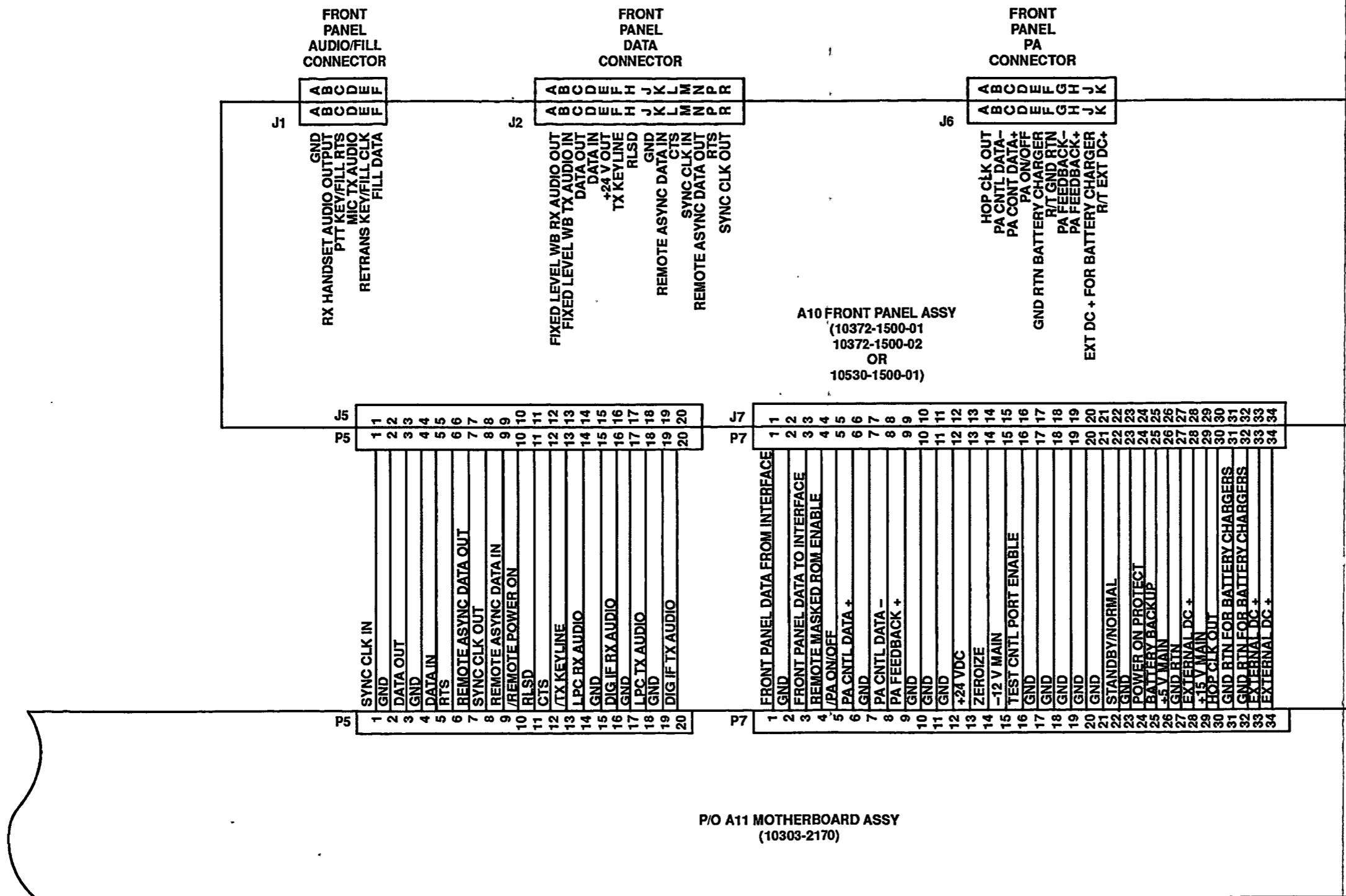

1694-037(A)
SHEET 6 OF 6

Figure 5-6. Receiver-Transmitter Interconnect Schematic Diagram (Sheet 6 of 6)

5.6 BIT DESCRIPTION

5.6.1 General

The receiver-transmitter has the ability to perform extensive self testing in the event of a failure. The receiver-transmitter also controls BIT for an external Pre/Postselector (if connected) and external power amplifier (if connected). The general types of tests and the assemblies affected are described in the following paragraphs.

5.6.2 BIT Routine

These tests can be automatically performed by rotating the Function switch to the TEST position, followed by pressing the [ENTER] key. During execution of the self test, the front panel message SELF TEST IN PROGRESS is displayed. If it is determined that a fault exists on a particular assembly, that assembly number and corresponding fault code number defining the type of failure will be displayed on the receiver-transmitter front panel alphanumeric display. All fault codes are listed in Table 5-4.

If initiating the self-test function results in no faults, the front panel message SELF TEST DONE NO ERRORS will be displayed.

5.6.3 BIT Test Description

The self-diagnostic routine used to verify the proper operation of the receiver-transmitter is described in the following paragraphs. It may be necessary to consult the specific functional block diagram for the circuit under discussion.

5.6.3.1 A1A1 Interface PWB Assembly BIT Sequence Description

The following paragraphs describe the sequence of tests performed on the A1A1 Interface PWB Assembly during execution of a receiver-transmitter self test routine.

5.6.3.1.1 Fault 01 – Communications Fault Test

The communications fault indicates that the Main Controller processor on the A4 Signal Processor PWB Assembly cannot communicate with the A1A1 Interface Assembly. It implies a fault that prevents the 87C51 microprocessor from running. In reality, this fault should not be able to occur because the Interface Assembly must be communicating in order for the operator to start the BITE test. A failure might indicate a problem with the BITE test internal timing.

5.6.3.1.2 Fault 02 – Microprocessor Internal RAM Fault Test

The microprocessor (internal RAM) fault indicates that the RAM internal to the interface microprocessor is faulty.

5.6.3.1.3 Fault 03 – ROM Fault Test

The ROM fault test verifies the proper operation of the program memory by performing an additive checksum test on the Programmable Read Only Memory (PROM). Every memory location in the PROM is added together and compared with a value stored in the PROM. Failing this test indicates either a faulty PROM or some other failure that prevents the microprocessor from correctly accessing program memory.

5.6.3.1.4 Fault 04 – RAM Fault Test

The RAM fault verifies the proper operation of the Complimentary Metal Oxide Semiconductor (CMOS) RAM. It performs a nondestructive test of all memory locations, first saving the data, then writing and reading a pattern from each address location.

5.6.3.1.5 Fault 05 – Asynchronous Data Channel Fault Test

This test verifies the internal operation of a Dual Universal Synchronous/Asynchronous Receiver-Transmitter (DUSART) on A1A1 Interface PWB Assembly. It performs an internal loop-back test. This DUSART provides communication between the data port serial lines and the microprocessor.

5.6.3.1.6 Fault 06 – Synchronous Data Channel Fault Test

This test verifies the internal operation of a DUSART on the A1A1 Interface PWB Assembly. It performs an internal loop-back test. This DUSART provides communication between the data port serial lines and the microprocessor.

5.6.3.1.7 Fault 09 – Remote Communications Channel Fault Test

This test verifies the operation of a DUSART on the A1A1 Interface PWB Assembly. It performs an internal loop-back test. This DUSART is used to communicate with the front panel and the auxiliary remote port.

5.6.3.1.8 Fault 0A – External PA DUART Counter Fault Test

Perform the following DUART counter fault test to verify the operation of the baud rate generator internal to the DUART.

5.6.3.1.9 Fault 0B – External PA Communications Channel Fault Test

The DUART serial data fault test verifies operation of the DUART. It performs internal testing of the integrated circuit as well as a loop-back test on board. The DUART is used to communicate with the power amplifiers and antenna couplers in the system. This communication is performed via high-speed serial data using a proprietary Harris protocol. The data is sent using a bidirectional link; therefore, any data sent is also received.

5.6.3.1.10 Faults 0F – Frame Clock Fault Test

The frame clock fault test verifies the ability of the A1A1 Interface PWB Assembly microprocessor to detect activity on the frame clock line. The frame clock is used to synchronize data transfers between the A1A1 Interface PWB Assembly and the modem portion of the A4 Signal Processor PWB Assembly. This line pulses at a regular rate whenever the modem is enabled.

5.6.3.1.11 Fault 10 – Semaphore Register Fault Test

This test verifies the A1A1 Interface PWB Assembly's half of the A1A2 Encryption PWB Assembly's dual port RAM semaphore registers.

5.6.3.1.12 Fault 11 – Dual Port RAM Fault Test

This test performs a non-destructive RAM test of the dual port RAM on A1A2 Encryption PWB Assembly.

5.6.3.1.13 Fault 51 – RTC Fault Test

This failure indicates that the real-time clock on the A1A1 Interface PWB Assembly does not respond to any signals that are sent to it.

5.6.3.1.14 Fault 52 – RTC Internal RAM Fault Test

A non-destructive RAM test is done during BITE on two blocks of RAM within the real-time clock.

5.6.3.1.15 Fault 55 – RTC Rollover Registers Fault Test

This fault indicates that the internal time of the real-time clock is not functioning correctly.

5.6.3.1.16 Fault 56 – RTC Crystal Oscillator Fault Test

Check for the presence of a specific square wave at the real-time clock.

5.6.3.1.17 Fault 81 – Encryption No Communication Fault Test

This test verifies that the A1A1 Interface PWB Assembly can communicate with the A1A2 Encryption PWB Assembly during self-test.

5.6.3.2 A1A2 Encryption PWB Assembly BIT Sequence Description

The following paragraphs describe the sequence of tests performed on the A1A2 Encryption PWB Assembly during execution of a receiver-transmitter self-test routine.

5.6.3.2.1 Fault 81 – Communications Fault Test

This fault indicates the interface microprocessor cannot communicate with the encryption microprocessor via the dual-port RAM.

5.6.3.2.2 Fault 82 – ROM Fault Test

This fault indicates that the internal additive checksum test for the ROM has failed.

5.6.3.2.3 Fault 83 – Internal RAM Fault Test

This fault indicates a problem within the encryption microprocessor.

5.6.3.2.4 Fault 84 – External RAM Fault Test

This fault indicates a problem with the external RAM.

5.6.3.2.5 Fault 85 – Dual-Port RAM Fault (Encryption Side) Test

This fault indicates a problem with dual-port RAM.

5.6.3.2.6 Fault 86 – Semaphore Register Fault (Encryption Side) Test

The semaphore registers are also part of the dual-port RAM. If this test fails, however, it means that the test for Fault 85 passed, limiting the possible causes of this fault.

5.6.3.2.7 Fault 87 – ACE Fault Test

This fault indicates that the microprocessor is unable to communicate with the Advanced Crypto Engine (ACE), or that the ACE is defective.

5.6.3.2.8 Fault 88 – HSS Register Fault Test

This fault indicates that the microprocessor is unable to communicate with the HSS, or that the HSS is defective.

5.6.3.2.9 Fault 89 – Encryption Loop Back Fault Test

This test encrypts and then decrypts an internally generated bit stream. A fault indicates a possible problem with several ICs on A1A2 Encryption PWB Assembly.

5.6.3.3 A3 LPC Vocoder Assembly BIT Sequence Description

The following paragraphs describe the sequence of tests performed on the A3 LPC Vocoder Assembly during execution of a receiver-transmitter self-test routine.

5.6.3.3.1 Fault 01 – 8751 Communications Fault Test

This fault indicates that the LPC microprocessor has lost communications with the HSSB.

5.6.3.3.2 Fault 02 – 8751 ROM Fault Test

This fault indicates that the ROM test has failed.

5.6.3.3.3 Fault 03 – 8751 Microprocessor Internal RAM Fault Test

This fault indicates a problem with the internal RAM.

5.6.3.3.4 Fault 05 – 8751 Dual-Port RAM Fault Test

This test indicates a problem with the 8751 dual-port RAM on the A3 LPC Vocoder Assembly.

5.6.3.3.5 Fault 06 – 8751 Dual-Port RAM Busy Fault Test

This test indicates a problem with the 8751 dual-port RAM on the A3 LPC Vocoder Assembly.

5.6.3.3.6 Fault 07 – 8751 Dual-Port RAM Interrupt Fault Test

This test indicates a problem with the 8751 dual-port RAM on the A3 LPC Vocoder Assembly.

5.6.3.3.7 Fault 14 – Hop Clock Fault Test

This test verifies that there is a hop clock signal at the A3 LPC Vocoder Assembly during BITE.

5.6.3.3.8 Fault 15 – Frame Clock Fault Test

This test verifies that there is a frame clock signal at the A3 LPC Vocoder Assembly during BITE.

5.6.3.3.9 Fault 81 – TMS320 Internal RAM Fault Test

This test indicates that the A4 Signal Processor PWB Assembly is not waiting long enough for the LPC BITE test to conclude.

5.6.3.3.10 Fault 82 – TMS320 External Program RAM Fault Test

This test indicates that the A4 Signal Processor PWB Assembly is not waiting long enough for the LPC BITE test to conclude.

5.6.3.3.11 Fault 83 – TMS320 External Data RAM Fault Test

This test indicates that the A4 Signal Processor PWB Assembly is not waiting long enough for the LPC BITE test to conclude.

5.6.3.3.12 Fault 84 – TMS320 ROM Fault Test

This test indicates that the A4 Signal Processor PWB Assembly is not waiting long enough for the LPC BITE test to conclude.

5.6.3.3.13 Fault 85 – TMS320 Dual-Port RAM Fault Test

This test indicates that the A4 Signal Processor PWB Assembly is not waiting long enough for the LPC BITE test to conclude.

5.6.3.3.14 Fault 86 – Sample Clock Fault Test

This test indicates that the A4 Signal Processor PWB Assembly is not waiting long enough for the LPC BITE test to conclude.

5.6.3.3.15 Fault 87 – TMS320 AIC Fault Test

This test indicates that the A4 Signal Processor PWB Assembly is not waiting long enough for the LPC BITE test to conclude.

5.6.3.3.16 Fault 88 – TMS320 DAC Fault Test

This test indicates that the A4 Signal Processor PWB Assembly is not waiting long enough for the LPC BITE test to conclude.

5.6.3.3.17 Fault F5 – 8751 Not Finished Fault Test

This test indicates that the A4 Signal Processor PWB Assembly is not waiting long enough for the LPC BITE test to conclude.

5.6.3.3.18 Fault FA – TMS320 Not Finished Fault Test

This test indicates that the A4 Signal Processor PWB Assembly is not waiting long enough for the LPC BITE test to conclude.

5.6.3.4 A4 Signal Processor PWB Assembly BIT Sequence Description

The following paragraphs describe the sequence of tests performed on the A4 Signal Processor PWB Assembly during execution of a receiver-transmitter self-test routine.

5.6.3.4.1 Fault 01 – Communications Fault Test

This fault occurs when the FEC processor does not respond to the main controller via the internal HSSB.

5.6.3.4.2 Fault 14 – Hop Clock Error Test

The main controller is unable to detect a hop clock signal.

NOTE

It is possible that the A3 LPC Vocoder Assembly or the A11 Motherboard Assembly could be holding the Hop Clock Signal.

5.6.3.4.3 Fault 15 – Frame Clock Fault Test

This fault occurs when the main controller microprocessor is unable to detect a pulse on the FRAM_CLK line.

NOTE

It is possible that the A1A1 Interface PWB Assembly or the A3 LPC Vocoder Assembly is holding this line, causing this fault.

5.6.3.4.4 Fault 1F – FEC ROM Checksum Fault Test

This fault indicates that the FEC microprocessor has detected a checksum error in its FLASH PROM.

5.6.3.4.5 Fault 20 – FEC External RAM Fault Test

The FEC microprocessor cannot write to and read back from all locations in its external RAM.

5.6.3.4.6 Fault 21 – FEC Dual-Port RAM Fault Test

The modem microprocessor cannot read to and read back from all locations of the dual-port RAM.

5.6.3.4.7 Fault 22 – 80C186 (U75) MDM Not Running Test

The modem microprocessor is unable to respond to commands from the main control microprocessor through the dual-port RAM.

5.6.3.4.8 Fault 23 – FFT Handshake Fault Test

This fault indicates that one of the modem microprocessors cannot communicate with another modem microprocessor via the dual-port RAM.

5.6.3.4.9 Fault 24 – FFT to MDM Dual-Port RAM Fault Test

This fault indicates that one of the modem microprocessors cannot write to and read back from dual-port RAM.

5.6.3.4.10 Fault 25 – MDM to FFT Dual-Port RAM Fault Test

This fault indicates that one of the modem microprocessors cannot write to and read back from dual-port RAM.

5.6.3.4.11 Fault 26 – MDM to FEC Dual-Port RAM Fault Test

This fault indicates that one of the modem microprocessors cannot write to and read from its side of dual-port RAM.

5.6.3.4.12 Fault 27 – MDM ROM Checksum Fault Test

This fault indicates that one of the modem microprocessors has detected a checksum fault in its EPROM.

5.6.3.4.13 Fault 28 – MDM RAM Fault Test

This fault indicates that one of the modem microprocessors cannot read and write to every location in its RAM.

5.6.3.4.14 Fault 29 – Sample Clock Fault Test

This fault indicates that one of the modem microprocessors detected an incorrect sample clock rate.

5.6.3.4.15 Fault 2A – FFT ROM Checksum Test

This failure indicates that the one of the modem microprocessors has detected a checksum error in its EPROM.

5.6.3.4.16 Fault 2B – FFT Internal RAM Fault Test

This test indicates that one of the modem microprocessors is unable to read and write to all its internal RAM locations.

5.6.3.4.17 Fault 2C – FFT External RAM Fault Test

This fault indicates that one of the modem microprocessors is unable to write and read to every location in its external RAM space.

5.6.3.4.18 Fault 2D – FFT to DIF Dual-Port RAM Fault Test

This fault indicates that one of the modem microprocessors cannot write to and read from its side of the dual-port RAM.

5.6.3.4.19 Fault 2E – Hop Clock Error Test

The main controller is unable to detect a hop clock signal.

NOTE

It is possible that the A3 LPC Vocoder Assembly or the A11
Motherboard Assembly could be holding the Hop Clock Signal.

5.6.3.4.20 Fault 2F – FFT Self Test (Not Complete) Test

This fault indicates that one of the modem microprocessors did not reply after it was commanded to test its side of the dual-port RAM.

5.6.3.4.21 Fault 30 – FFT Self Test (Not Complete) Test

This fault indicates that one of the modem microprocessors did not reply after it was commanded to test its internal and external RAMs and its ROM.

5.6.3.4.22 Fault 32 – Digital IF Time Sample Transfer Test

This test transfers known data to the digital IF processor via two modem microprocessors and dual-port RAM.

5.6.3.4.23 Fault 33 – MDM Self Test (Not Complete) Test

This fault indicates that one of the modem microprocessors did not return from performing its self test after being commanded to perform its test.

5.6.3.4.24 Fault 34 – FEC Self Test (Not Complete) Test

This fault indicates that one of the modem microprocessors had not finished its self test when the main controller polled it for its test results.

5.6.3.4.25 Fault 42 – Non-Destructive Internal RAM Fault Test

This fault indicates that the internal RAM for the main controller is faulty.

5.6.3.4.26 Fault 43 – ROM Checksum Fault Test

The main controller detects a checksum error in its flash EPROM.

5.6.3.4.27 Fault 44 – Non-destructive External RAM Fault Test

This test indicates a faulty main controller RAM.

5.6.3.4.28 Fault 61 – AGC Communication Fault Test

This indicates that the main controller cannot communicate with the AGC processor over the HSSB.

5.6.3.4.29 Fault 62 – AGC Processor Internal RAM Test

This is a non-destructive test of the on-chip RAM of the microcontroller.

5.6.3.4.30 Fault 63 – AGC Checksum Fault Test

This test performs an additive checksum test on all bytes in the program storage ROM. If any locations are bad or incorrectly programmed, this fault will occur.

5.6.3.4.31 Fault 64 – AGC External RAM Fault Test

This is a nondestructive test that tests all of the external RAM on the microcontroller bus. If this fault code occurs, it is likely that the external RAM device being tested is bad. A faulty address or data line to the part may also be the problem.

5.6.3.4.32 Fault 67 – Digital IF Handshake Fault (Dual Port RAM) Test

This tests the interrupt generation of the AGC and IF processors. If this test fails, the IF processor is probably not running.

5.6.3.4.33 Fault 6B – Digital IF Did Not Complete BITE Test

The digital IF is a much faster processor than the 80C51FA, and should have completed its test well before the AGC processor.

5.6.3.4.34 Fault 6C – Anti-alias Filter Test

This test checks the response of the active low pass filter. The IF processor generates a series of tones starting at 100 Hz and finishing at 16 kHz. The A/D converters perform a peak detect on the signal at the output of the filter, and this is compared to a table of acceptable limits. During a self test, this sweep generator can be heard in the handset. Failures in this test are most likely incorrect passive elements in the active filter circuit.

5.6.3.4.35 Fault 6D – 28.8-kHz Sample Clock Fault and Fault 6E – 24.0-kHz Sample Clock Fault Test

During this test, the IF processor simply measures the duty cycle and period of the sample clock using the 36-MHz processor clock as a reference. This is a crude test, but it functions as desired. It will not, however, detect a noisy sample clock that is the correct frequency. Both 24-kHz and 28.8-kHz clocks are checked.

5.6.3.4.36 Fault 74 – Frame Clock Not Detected Test

The main controller generates a frame clock pulse, and the AGC processor reports if the clock pulse was detected or not.

5.6.3.4.37 Fault 75 – Hop Clock Not Detected Test

This test is identical to the frame clock test, but a different hardware line is tested.

5.6.3.4.38 Fault 80 – Digital IF ROM Checksum Fault Test

This test checks the integrity of the digital IF ROM integrated circuit.

5.6.3.4.39 Fault 81 – Digital IF Internal RAM Fault Test

This test checks the integrity of the digital IF ROM integrated circuit.

5.6.3.4.40 Fault 82 – Digital IF External RAM Fault Test

This test is identical to the one the main controller performs, but it is performed on the digital IF's dedicated external RAM.

5.6.3.4.41 Fault 83 – Dual-Port RAM to AGC Fault Test

These tests are the same tests that are performed on external RAMs. Dual port RAMs are also external and are accessed in the same manner. Faults here may occur because the part is bad or a faulty address or data line to the part may exist. Also, any glue logic that is used to address or enable the part may be at fault.

5.6.3.4.42 Fault 84 – Dual-Port RAM to FFT Fault Test

This test is identical to the dual port RAM to AGC processor test, but it is performed on the 16-bit wide part that interfaces the IF processor to the FFT processor.

5.6.3.5 A5 Receiver/Exciter Assembly BIT Sequence Description

The following paragraphs describe the sequence of tests performed on A5 Receiver/Exciter Assembly during execution of a receiver-transmitter self-test routine.

5.6.3.5.1 Receiver Faults 01 through 04

Receiver BITE faults are determined by the digital and analog AGC control outputs.

5.6.3.5.2 Exciter Faults 0F through 12

Exciter gain faults are determined by the ATTEN CTRL line value measured by the software. Exciter output faults are determined by the level detectors placed on the Power Amplifier Assembly, after the A5 Receiver/Exciter Assembly output.

5.6.3.6 A6 Synthesizer Assembly BIT Sequence Description

The following paragraphs describe the sequence of tests performed on the A6 Synthesizer Assembly during execution of a receiver-transmitter self-test routine.

5.6.3.6.1 Fault 12 – Combined Lock Detect Fault Test

This test verifies that the three Phase-Locked Loops (PLLs) on the A6 Synthesizer Assembly are functioning properly. This test is performed after the serial data fault test.

5.6.3.6.2 Fault 20 – Serial EEPROM Data Read Fault Test

This test verifies that the main controller on the A4 Signal Processor PWB Assembly was able to verify the checksum of the EEPROM on the A6 Synthesizer Assembly.

5.6.3.7 A8 Power Amplifier/Battery Charger Assembly BIT Sequence Description

This assembly has a single BITE test, which is to attempt to transmit 5 watts of RF power into the BITE test load on the harmonic filter subassembly. If the RF is able to pass through each of the eight possible filter bands, the test passes.

5.6.3.8 A9 Antenna Coupler Assembly BIT Sequence Description

The following paragraphs describe the sequence of tests performed on the A9 Antenna Coupler Assembly during execution of a receiver-transmitter self-test routine.

5.6.3.8.1 Fault 01 – Coupler Operational Fault Test

This fault occurs when the receiver-transmitter attempts to transmit 100 mW CW and fails to detect the presence of any modulated RF at the antenna coupler discriminator.

5.6.3.9 A10 Front Panel Assembly BIT Sequence Description

The following paragraphs describe the sequence of tests performed on A10 Front Panel Assembly during execution of a receiver-transmitter self-test routine.

5.6.3.9.1 Fault 02 – Microprocessor Internal RAM Fault Test

This fault occurs if the front panel microprocessor determines that its internal RAM is defective.

5.6.3.9.2 Fault 03 – ROM Fault Test

This fault occurs if the checksum calculated and recorded in the program ROM during factory programming does not match the checksum calculated by the microprocessor during self-test.

5.6.3.9.3 Fault 04 – External RAM Fault Test

During a check of external RAM, one or more bits are detected as being stuck as logic 0s or logic 1s. This may also be the result of open or shorted address, data, or control lines.

5.6.3.9.4 Fault 05 – LCD Fault Test

An LCD fault indicates that the microprocessor cannot communicate with the LCD board.

5.6.3.10 Self-Diagnostics Sequence Summary

The order of testing from the first to last test is shown in Table 5-7.

Table 5-7. Self-Diagnostics Sequence Summary

Sequence	Fault Code
Communications Fault Test	A1 F01
Communications Fault Test	A4 F01
8751 Communications Fault Test	A3 F01
ROM Checksum Fault Test	A4 F43
Non-Destructive Internal RAM Fault Test	A4 F42
Non-Destructive External RAM Fault Test	A4 F44
Hop Clock Error Test	A4 F14
Combined Lock Detect Fault Test	A6 F12
Serial EEPROM Data Read Fault Test	A6 F20
ROM Fault Test	A1 F03
Microprocessor Internal RAM Fault Test	A1 F02
Semaphore Register Fault Test	A1 F10
Dual Port RAM Fault Test	A1 F11
RAM Fault Test	A1 F04
Asynchronous Data Channel Fault Test	A1 F05
Synchronous Data Channel Fault Test	A1 F06
Remote Communications Channel Fault Test	A1 F09
External PA DUART Counter Fault Test	A1 F0A
External PA Communications Channel Fault Test	A1 F0B
Real-Time Clock Fault Test	A1 F51
Real-Time Clock Internal RAM Fault Test	A1 F52
Real-Time Clock Rollover Registers Fault Test	A1 F55
Real-Time Clock Crystal Oscillator Fault Test	A1 F56
Encryption No Communication Fault Test	A1 F81
ROM Fault Test	A1 F82
Internal RAM Fault Test	A1 F83
External RAM Fault Test	A1 F84
Semaphore Register Fault Test (Encryption Side)	A1 F86
Dual-Port RAM Fault Test (Encryption Side)	A1 F85
Advanced Crypto Engine (ACE) Fault Test	A1 F87
HSS Register Fault Test	A1 F88
Encryption Loop Back Fault Test	A1 F89
FEC Dual-Port RAM Fault Test	A4 F21
FEC ROM Checksum Fault Test	A4 F1F

Table 5-7. Self-Diagnostics Sequence Summary – Continued

Sequence	Fault Code
FEC External RAM Fault Test	A4 F20
80C186 Modem Not Running Test	A4 F22
FFT Handshake Fault Test	A4 F23
FFT to Modem Dual-Port RAM Fault Test	A4 F24
Modem to FFT Dual-Port RAM Fault Test	A4 F25
Modem to FEC Dual-Port RAM Fault Test	A4 F26
Modem ROM Checksum Fault Test	A4 F27
Modem RAM Fault Test	A4 F28
Sample Clock Fault Test	A4 F29
FFT ROM Checksum Test	A4 F2A
FFT Internal RAM Fault Test	A4 F2B
FFT External RAM Fault Test	A4 F2C
FFT to DIF Dual-Port RAM Fault Test	A4 F2D
FFT Self Test Not Complete Fault Test	A4 F2F
FFT Self Test Not Complete Fault Test	A4 F30
Modem Self Test Not Complete Test	A4 F33
FEC Self Test Not Complete Test	A4 F34
8751 ROM Fault Test	A3 F02
8751 Microprocessor Internal RAM Fault Test	A3 F03
8751 Dual-Port RAM Fault Test	A3 F05
8751 Dual-Port RAM Busy Fault Test	A3 F06
8751 Dual-Port RAM Interrupt Fault Test	A3 F07
TMS320 Not Finished Fault Test	A3 FA
TMS320 Internal RAM Fault Test	A3 F81
TMS320 ROM Fault Test	A3 F84
TMS320 External Program RAM Fault Test	A3 F82
TMS320 External Data RAM Fault Test	A3 F83
TMS320 Dual-Port RAM Fault Test	A3 F85
Sample Clock Fault Test	A3 F86
TMS320 AIC Fault Test	A3 F87
TMS320 DAC Fault Test	A3 F88
8751 Not Finished Fault Test	A3 F5
AGC Communication Fault Test	A4 F61
AGC Checksum Fault Test	A4 F63
AGC Processor Internal RAM Test	A4 F62
AGC External RAM Fault Test	A4 F64

Table 5-7. Self-Diagnostics Sequence Summary – Continued

Sequence	Fault Code
Digital IF ROM Checksum Fault Test	A4 F80
Digital IF Internal RAM Fault Test	A4 F81
Digital IF External RAM Fault Test	A4 F82
Dual-Port RAM to AGC Fault Test	A4 F83
Dual-Port RAM to FFT Fault Test	A4 F84
Digital IF Did Not Complete BITE Test	A4 F6B
Digital IF Handshake Fault Test	A4 F67
28.8 kHz Sample Clock Fault Test	A4 F6D
24.0 kHz Sample Clock Fault Test	A4 F6E
Anti-Alias Filter Test	A4 F6C
Digital IF Time Sample Transfer Test	A4 F32
Hop Clock Not Detected Test	A4 F75
Hop Clock Error Test	A4 F2E
Hop Clock Fault Test	A3 F14
Frame Clock Fault Test	A4 F15
Frame Clock Fault Test	A01 F0F
Frame Clock Not Detected Test	A4 F74
Frame Clock Fault Test	A3 F15
LCD Fault Test	A10 F05
ROM Fault Test	A10 F03
External RAM Fault Test	A10 F04
Microprocessor Internal RAM Fault Test	A10 F02
Digital and Analog AGC Control Output Fault Tests	A5 F01 – F04
Exciter Gain Faults and Exciter Output Fault Tests	A5 F0F – F12
Filter Band Fault Tests	A8 F00 – FFF
Coupler Operational Fault Test	A9 F01

CHAPTER 6

CORRECTIVE MAINTENANCE

6.1 INTRODUCTION

Paragraph 6.2 provides the alignment and adjustment procedures for each Shop Replaceable Unit (SRU) in the receiver-transmitter. Paragraph 6.3 provides the procedures for removing and replacing the SRUs. The procedures in both paragraphs are arranged in order of the SRU reference designators. These SRUs are listed in Table 6-1, with a reference to the corresponding removal and replacement procedure paragraph.

6.1.1 Master Tools and Materials List

Table 6-2 lists the tools, test equipment, and materials required for the procedures in this chapter. Column 1, Item, gives the item number which is referenced in parentheses next to the tool name in each procedure.

Table 6-1. SRUs and Removal and Replacement Paragraph References

SRU Name	Paragraph Reference
A1A1 Interface Printed Wiring Board (PWB) Assembly	6.5.3
A1A2 Encryption PWB Assembly (RT-1694(P) configuration only)	6.5.3
A3 Linear Predictive Coding (LPC) Vocoder Assembly	6.5.4
A4 Signal Processor PWB Assembly	6.5.5
A5 Receiver/Exciter Assembly	6.5.6
A6 Synthesizer Assembly	6.5.7
A7 Power Supply Assembly	6.5.8
A8 Power Amplifier (PA)/Battery Charger Assembly	6.5.9
A9 Antenna Coupler Assembly	6.5.10
A10 Front Panel Assembly	6.5.11
A11 Motherboard Assembly	6.5.12
W1 Coaxial Cable Assembly	6.5.13
W2 Coaxial Cable Assembly	6.5.14

Table 6-2. Master Tools and Materials List

Item	Description	Part Number	Cage Code
1	Screwdriver, No. 0 Cross-Tip	X-100	96508
2	Screwdriver, No.1 Cross-Tip	X-101	96508
3	Screwdriver, No. 2 Cross-Tip	X-102	96508
4	Hex Screwdriver Bit, 5/32 Inch	99-25	96508
5	Jewelers Pliers, 4 Inch	LN54	19915
6	Socket Wrench, 3/16 Inch	99-6	96508
7	Screwdriver Handle	99-1	96508
8	Ground Strap	3M-2064	20999
9	Electrostatic Discharge (ESD) Mat	1872	20999

6.2 ADJUSTMENTS AND ALIGNMENTS

6.2.1 General

The receiver-transmitter requires no Level III adjustments or alignments.

6.3 REMOVAL AND REPLACEMENT PROCEDURES

The following paragraphs contain the repair procedures which consist of removing and replacing all SRUs authorized for Level III maintenance. SRUs consist of assemblies, PWBs, and cables.

6.3.1 Safety

Remove power from the radio system before starting any repairs.

WARNING

Voltages hazardous to human life are present if power is not removed from the unit. Failure to remove power from the unit can cause injury or death to personnel.

6.3.2 Level III Repair

Repairs are made by removing and replacing the assemblies listed in Table 6-1. Repairs are also made by removing and replacing damaged cables, listed in Table 6-3.



Some of the assemblies in the receiver-transmitter can be damaged by static discharge. Failure to take the proper precautions may damage these assemblies. Use a ground strap (Item 8) and an ESD Mat (Item 9) whenever removing or replacing these assemblies. For more information, refer to the Safety Summary at the beginning of this manual.

6.3.3 Attaching Hardware

Table 7-3 lists the attaching hardware that is removed and replaced while performing the procedures in this chapter. Column 1, Letter Code, gives the letter which is referenced in parentheses next to the attaching hardware in each procedure.

6.3.4 Repair Tips

When an assembly is removed from the unit, non-captive hardware should be stored at the time of disassembly. Re-use this hardware when installing the assembly into the unit.

Also label all cable assemblies that are removed from the unit. This will aid in identifying the correct cables during assembly of the unit.

6.3.5 Tools

Use only the proper tools when performing maintenance tasks on the unit. Refer to Table 6-2. An incorrect size screwdriver or wrench can damage hardware.



Failure to use the correct tool can damage hardware.

6.3.6 Wires, Cables, and Connectors

Use the unit replacement illustrations to locate the cable connections, if necessary. Table 6-3 describes the cables by reference designation, part number, description, cable connectors, and unit connection points.



When removing or replacing wires, cables, or connectors, avoid sharp bends in any cable. Do not allow the cable to be pinched when reinstalling an assembly. When removing a ribbon connector, pull straight up to avoid bending the pins. Do not remove a connection by grabbing the cable; grab the connector instead. Do not force the cable when reinstalling it; this could damage the connector pins.

Table 6-3. Receiver-Transmitter Cable Information

Ref. Desig.	Part Number	Description	Cable Connector	Connection
P/O A5	10303-2600	Coaxial Cable Subassembly	A5A2P8	W2P2
P/O A6	10303-2700	Coaxial Cable Subassembly	A6A2W1J1	A5A2J2
W1	10372-1037-01	Radio Frequency (RF) Coaxial Cable Assembly (PA-Coupler)	P1 P2	A8A2J3 A9A1J2
W2	10372-1053-01	RF Coaxial Cable Assembly (PA-Receiver/Exciter)	P1 P2	A8A1J2 A5A2P8

6.4 UNIT REMOVAL AND REPLACEMENT PROCEDURES

6.4.1 General

This section contains information for the removal and replacement of the receiver-transmitter from a radio system.

6.4.2 Removing and Applying AC Input Power

AC input power must be removed before performing any unit replacement procedure.

6.4.2.1 Removing AC Input Power

If the receiver-transmitter is installed in a base station configuration, perform the following procedure to remove AC input power:

WARNING

Voltages hazardous to human life are present if power is not removed from the radio system. Failure to remove power from the radio system can cause injury or death to personnel.

- a. Turn the power switches on the individual units making up the RF-5200 Falcon™ Manpack Radio System to the OFF position.
- b. If AC power comes from a panel with circuit breaker switches, turn the circuit breaker powering the radio system to the OFF position.

6.4.2.2 Applying AC Input Power

This procedure assumes that AC power was removed per Paragraph 6.4.2.1. Perform the following procedure to apply AC input power:

WARNING

Voltages hazardous to human life are present when power is applied to the radio system. This power can cause injury or death to personnel.

- a. At the circuit breaker panel, turn the circuit breaker powering the radio system to the ON position.
- b. Turn the power switches on the individual units making up the radio system to the ON position.

6.4.3 Receiver-Transmitter Removal and Replacement

Procedures for removal and replacement of the receiver-transmitter vary, depending on the installation configuration. For information on how to remove and replace the receiver-transmitter from the rest of the radio system, refer to Chapter 8, Installation. Also refer to the RF-5200 Falcon™ Series Manpack System manual (10515-0006-4200).

6.5 SHOP REPLACEABLE UNIT (SRU) REMOVAL AND REPLACEMENT PROCEDURES

The following procedures contain information for the removal and replacement of SRUs in the receiver-transmitter. See Figure 6-1.

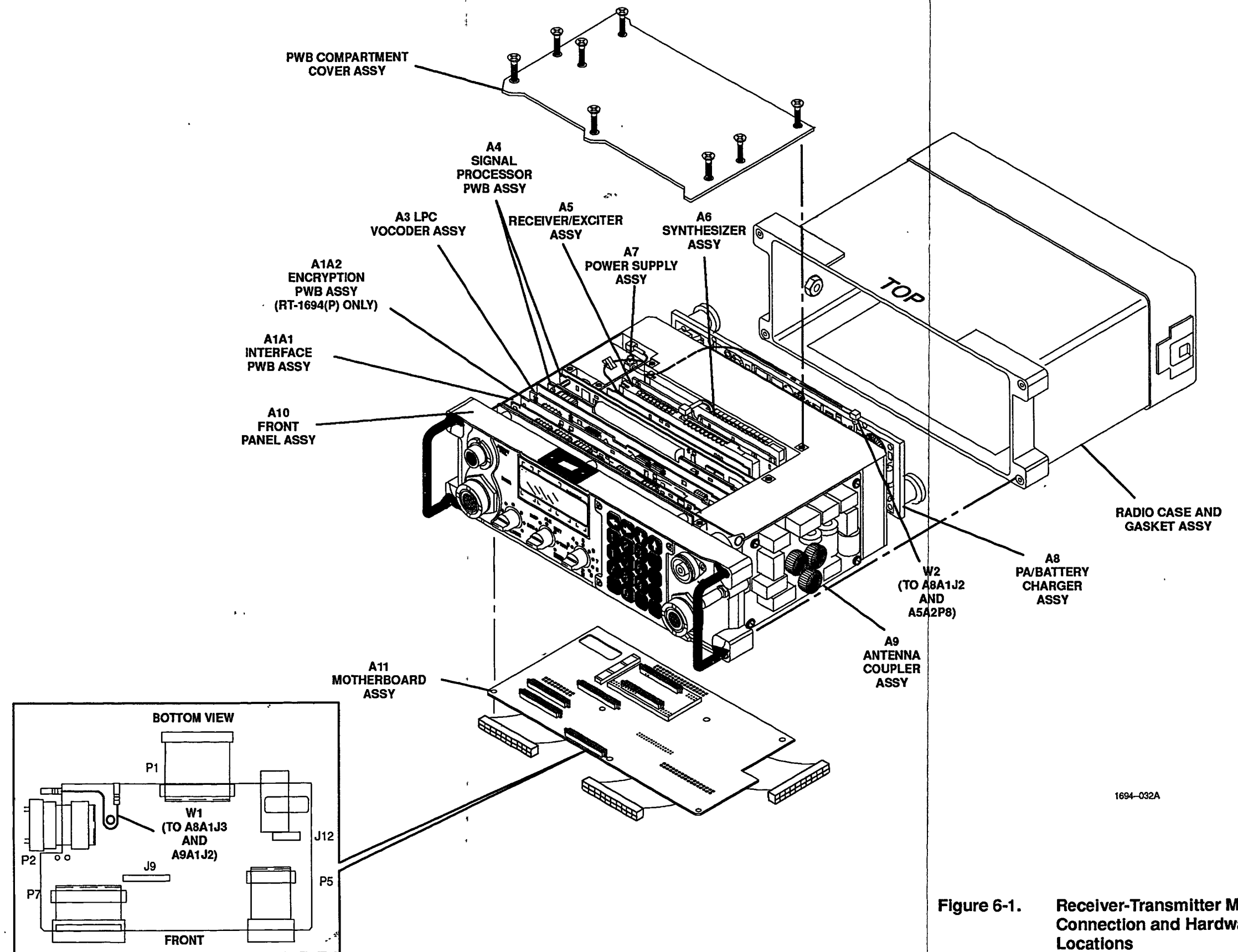

1694-032A

Figure 6-1. Receiver-Transmitter Master Connection and Hardware Locations

6.5.1 MP2 Radio Case and Gasket Assembly Removal and Replacement

The following paragraphs provide instructions for the removal and replacement of MP2 Radio Case and Gasket Assembly. See Figure 6-2.

WARNING

To prevent electrical shock and RF burns, remove all electrical connections to the receiver-transmitter before removing and replacing assemblies.

6.5.1.1 MP2 Radio Case and Gasket Assembly Removal

Perform the following procedure to remove MP2 Radio Case and Gasket Assembly from receiver-transmitter chassis:

- a. Use a hex screwdriver (Items 4 and 7) to loosen the four (4) captive hex screws that secure MP2 Radio Case and Gasket Assembly to the A10 Front Panel Assembly.
- b. Slide MP2 Radio Case and Gasket Assembly away from the A10 Front Panel Assembly and off of MP1 chassis.

6.5.1.2 MP2 Radio Case and Gasket Assembly Replacement

Perform the following procedure to replace MP2 Radio Case and Gasket Assembly onto the receiver-transmitter chassis:

- a. Position the MP1 chassis up and orient the case with the word "TOP" facing up.
- b. Slide MP2 Radio Case and Gasket Assembly onto MP1 chassis.
- c. Use a hex screwdriver (Items 4 and 7) to tighten the four (4) captive hex screws that secure MP2 Radio Case and Gasket Assembly to the A10 Front Panel Assembly.

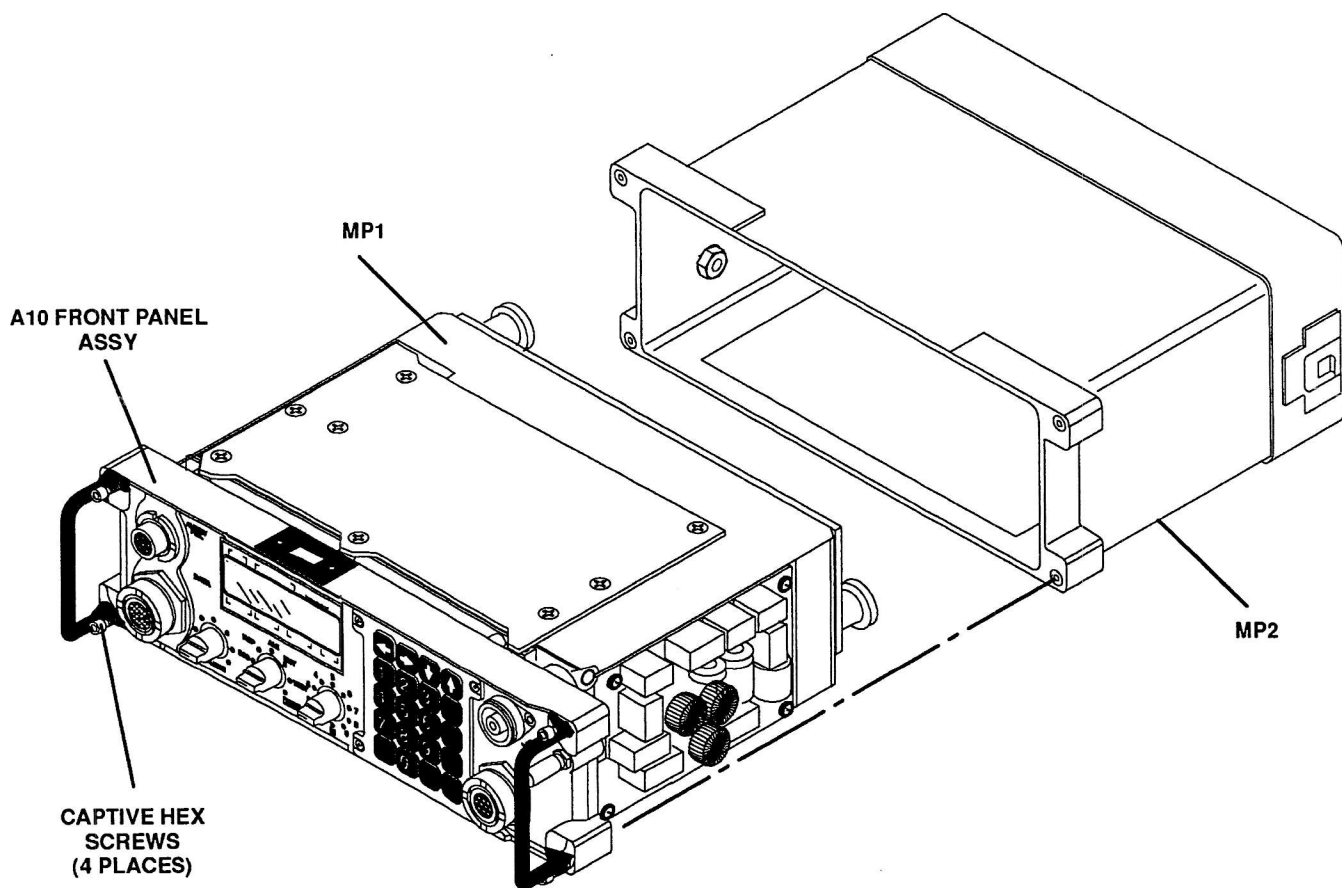

1694-008A

Figure 6-2. MP2 Radio Case and Gasket Assembly Removal and Replacement

6.5.2 MP3 PWB Compartment Cover Assembly Removal and Replacement

The following paragraphs provide instructions for the removal and replacement of MP3 PWB Compartment Cover Assembly. See Figure 6-3.

WARNING

To prevent electrical shock and RF burns, remove all electrical connections to the receiver-transmitter before removing and replacing assemblies.

6.5.2.1 MP3 PWB Compartment Cover Assembly Removal

Perform the following procedure to remove MP3 PWB Compartment Cover Assembly from the receiver-transmitter chassis:

- a. Remove MP2 Radio Case and Gasket Assembly per Paragraph 6.5.1.1.
- b. Use a cross-tip screwdriver (Item 2) to loosen the eight (8) captive screws that secure MP3 PWB Compartment Cover Assembly to MP1 chassis.
- c. Remove MP3 PWB Compartment Cover Assembly from MP1 chassis.

6.5.2.2 MP3 PWB Compartment Cover Assembly Replacement

Perform the following procedure to replace MP3 PWB Compartment Cover Assembly onto the receiver-transmitter chassis:

- a. Position MP3 PWB Compartment Cover Assembly onto MP1 chassis.
- b. Use a cross-tip screwdriver (Item 2) to tighten the eight (8) captive screws that secure MP3 PWB Compartment Cover Assembly to MP1 chassis.
- c. Replace MP2 Radio Case and Gasket Assembly per Paragraph 6.5.1.2.

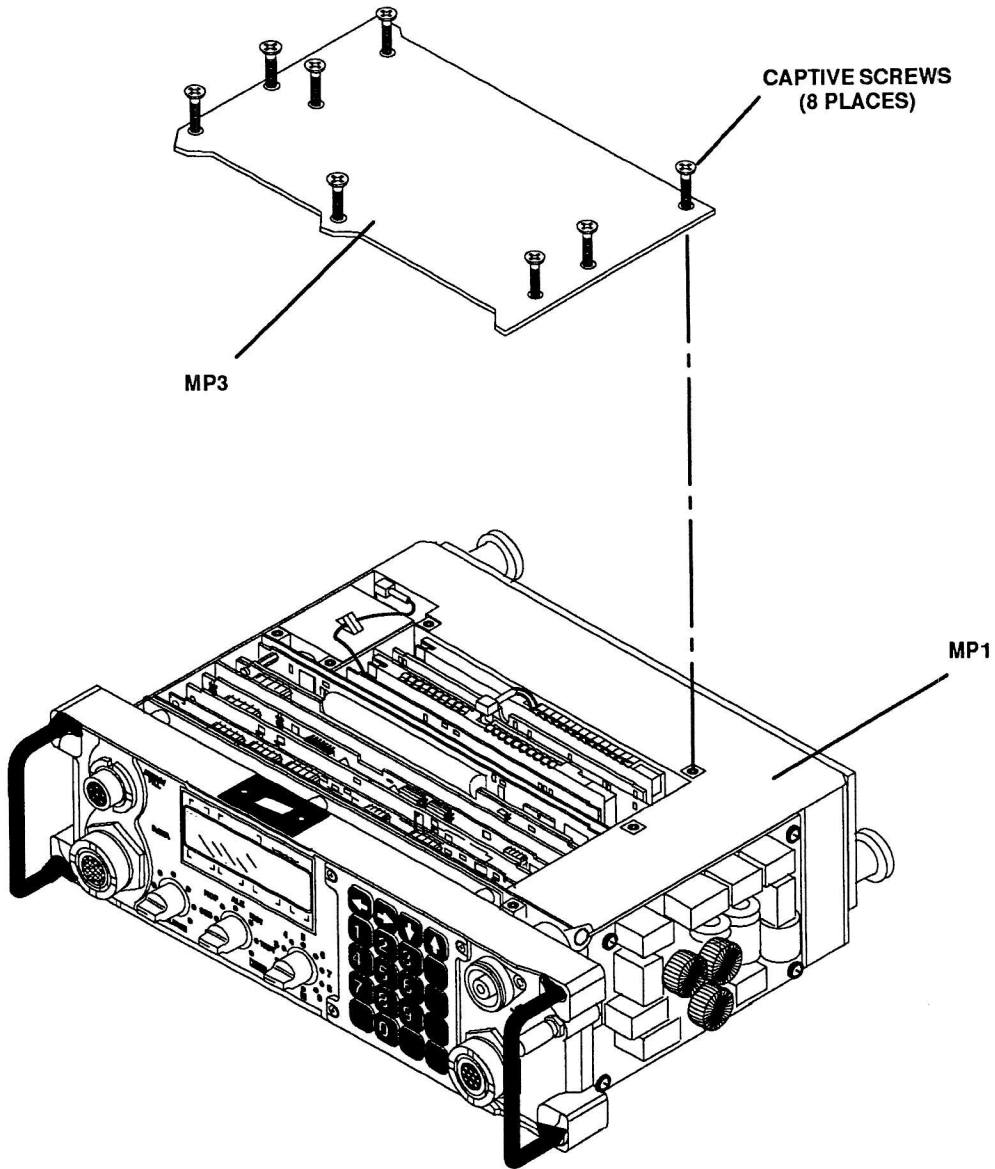

1694-009

Figure 6-3. MP3 PWB Compartment Cover Removal and Replacement

6.5.3 A1A1 Interface and A1A2 Encryption PWB Assembly Removal and Replacement

The following paragraphs provide instructions for the removal and replacement of the A1A1 Interface PWB Assembly and A1A2 Encryption PWB Assembly (if installed) from the receiver-transmitter. See Figure 6-4.

**WARNING**

To prevent electrical shock and RF burns, remove all electrical connections to the receiver-transmitter before removing and replacing assemblies.



Some components on the A1A1 Interface PWB Assembly and A1A2 Encryption PWB Assembly can be damaged by static discharge. Failure to take the proper precautions may damage these assemblies. For more information, refer to the Safety Summary at the beginning of this manual.

6.5.3.1 A1A1 Interface and A1A2 Encryption PWB Assembly Removal

Perform the following procedure to remove the A1A1 Interface PWB Assembly and A1A2 Encryption PWB Assembly (if installed) from the receiver-transmitter chassis:

- a. Remove MP2 Radio Case and Gasket Assembly per Paragraph 6.5.1.1.
- b. Remove MP3 PWB Compartment Cover Assembly per Paragraph 6.5.2.1.
- c. Remove the A1A1 and A1A2 assemblies from MP1 chassis by grasping the green cord between the assemblies and pulling upward.

NOTE

There is no green cord in units that do not have an A1A2 Encryption PWB Assembly installed. For these units, grasp the A1A1 assembly and pull upward.

- d. If the A1A2 Encryption PWB Assembly is installed, use a cross-tip screwdriver (Item 1) to remove the four (4) screws (D), lockwashers (E), and flatwashers (H) that secure the A1A2 assembly to the A1A1 assembly.
- e. If the A1A2 Encryption PWB Assembly is installed, separate the A1A1 assembly from the A1A2 assembly by pulling the two PWBs apart.

6.5.3.2 A1A1 Interface and A1A2 Encryption PWB Assembly Replacement

Perform the following procedure to replace the A1A1 Interface PWB Assembly and A1A2 Encryption PWB Assembly (if part of this radio's configuration) into the receiver-transmitter chassis:

- a. If the A1A2 Encryption PWB Assembly is part of this radio's configuration, connect the A1A1 assembly to the A1A2 assembly by aligning A1A1J2 with A1A2P2 and pushing the assemblies together.

NOTE

Ensure that the green cord is positioned on the A1A2 standoffs before pushing the assemblies together.

- b. If the A1A2 Encryption PWB Assembly is part of this radio's configuration, use a cross-tip screwdriver (Item 1) to install the four (4) screws (D), lockwashers (E), and flatwashers (H) that secure the A1A2 assembly to the A1A1 assembly.
- c. Slide the A1A1 and A1A2 assemblies into the empty slot in MP1 chassis and push downward.
- d. Replace MP3 PWB Compartment Cover Assembly per Paragraph 6.5.2.2.
- e. Replace MP2 Radio Case and Gasket Assembly per Paragraph 6.5.1.2.

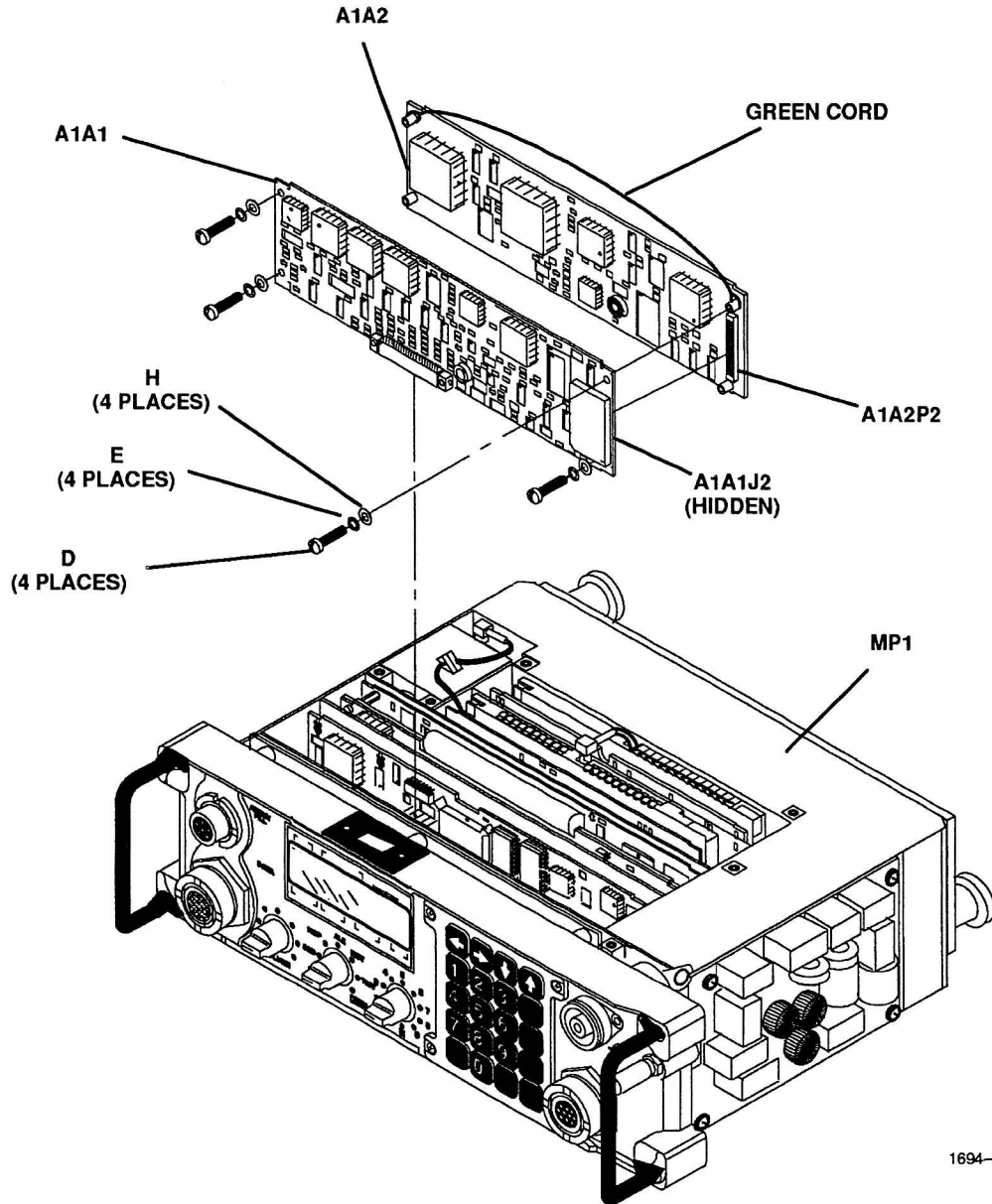

Figure 6-4. A1A1 Interface PWB Assembly and A1A2 Encryption PWB Assembly Connector and Hardware Locations

6.5.4 A3 LPC Vocoder Assembly Removal and Replacement

The following paragraphs provide instructions for the removal and replacement of the A3 LPC Vocoder Assembly from the receiver-transmitter. See Figure 6-5.

WARNING

To prevent electrical shock and RF burns, remove all electrical connections to the receiver-transmitter before removing and replacing assemblies.

CAUTION



Some components on the A3 LPC Vocoder Assembly can be damaged by static discharge. Failure to take the proper precautions may damage the assembly. For more information, refer to the Safety Summary at the beginning of this manual.

6.5.4.1 A3 LPC Vocoder Assembly Removal

Perform the following procedure to remove the A3 LPC Vocoder Assembly from the receiver-transmitter chassis:

- a. Remove MP2 Radio Case and Gasket Assembly per Paragraph 6.5.1.1.
- b. Remove MP3 PWB Compartment Cover Assembly per Paragraph 6.5.2.1.
- c. Remove the A3 LPC Vocoder Assembly from MP1 chassis by grasping the green cord and pulling upward.

6.5.4.2 A3 LPC Vocoder Assembly Replacement

Perform the following procedure to replace the A3 LPC Vocoder Assembly into the receiver-transmitter chassis:

- a. Slide the A3 LPC Vocoder Assembly into the empty slot in MP1 chassis and push downward.
- b. Replace MP3 PWB Compartment Cover Assembly per Paragraph 6.5.2.2.
- c. Replace MP2 Radio Case and Gasket Assembly per Paragraph 6.5.1.2.

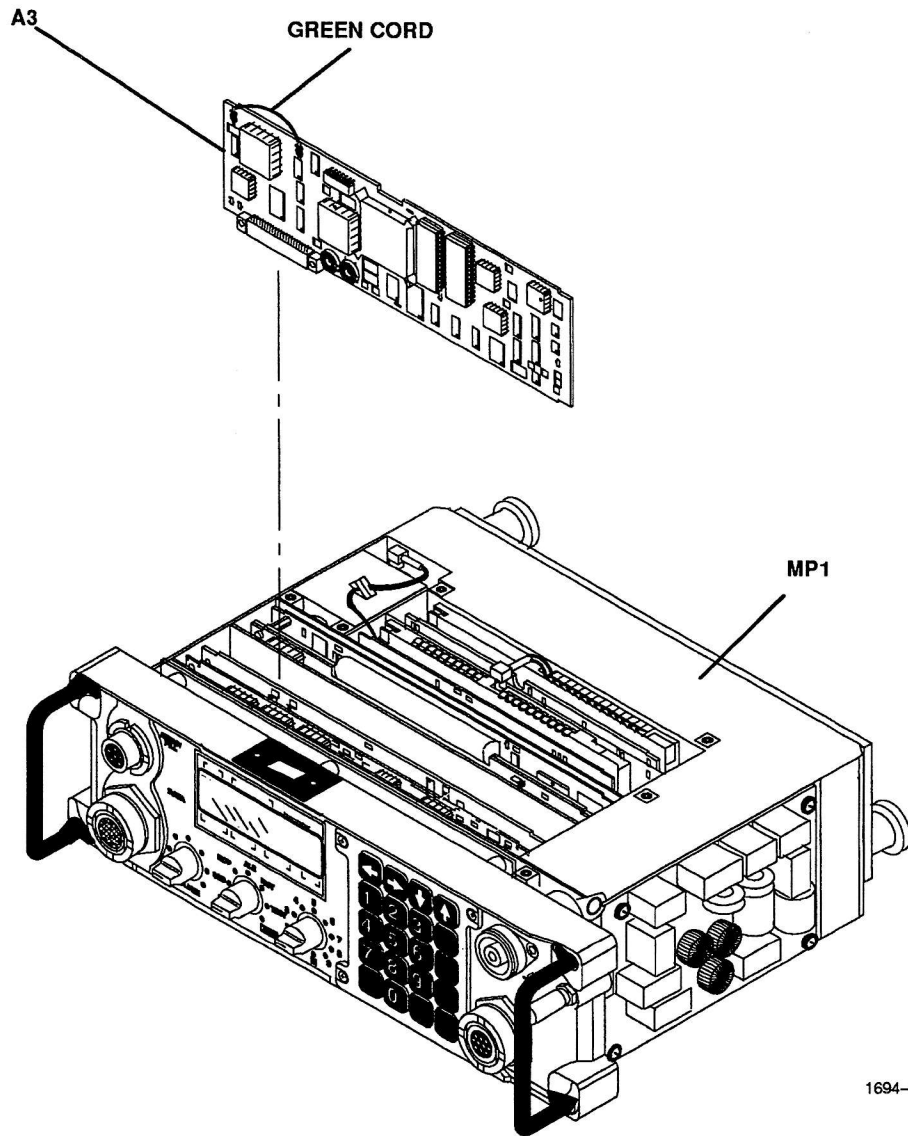

Figure 6-5. A3 LPC Vocoder Assembly Connector and Hardware Locations

6.5.5 A4 Signal Processor PWB Assembly Removal and Replacement

The following paragraphs provide instructions for the removal and replacement of the A4 Signal Processor PWB Assembly from the receiver-transmitter. See Figure 6-6.

WARNING

To prevent electrical shock and RF burns, remove all electrical connections to the receiver-transmitter before removing and replacing assemblies.

CAUTION



Some components on the A4 Signal Processor PWB Assembly can be damaged by static discharge. Failure to take the proper precautions may damage the assembly. For more information, refer to the Safety Summary at the beginning of this manual.

6.5.5.1 A4 Signal Processor PWB Assembly Removal

Perform the following procedure to remove the A4 Signal Processor PWB Assembly from the receiver-transmitter chassis:

- a. Remove MP2 Radio Case and Gasket Assembly per Paragraph 6.5.1.1.
- b. Remove MP3 PWB Compartment Cover Assembly per Paragraph 6.5.2.1.
- c. Remove the A4 Signal Processor PWB Assembly from MP1 chassis by grasping the green cord and pulling upward.

6.5.5.2 A4 Signal Processor PWB Assembly Replacement

Perform the following procedure to replace the A4 Signal Processor PWB Assembly into the receiver-transmitter chassis:

- a. Slide the A4 Signal Processor PWB Assembly into the empty slot in MP1 chassis and push downward.
- b. Replace MP3 PWB Compartment Cover Assembly per Paragraph 6.5.2.2.
- c. Replace MP2 Radio Case and Gasket Assembly per Paragraph 6.5.1.2.

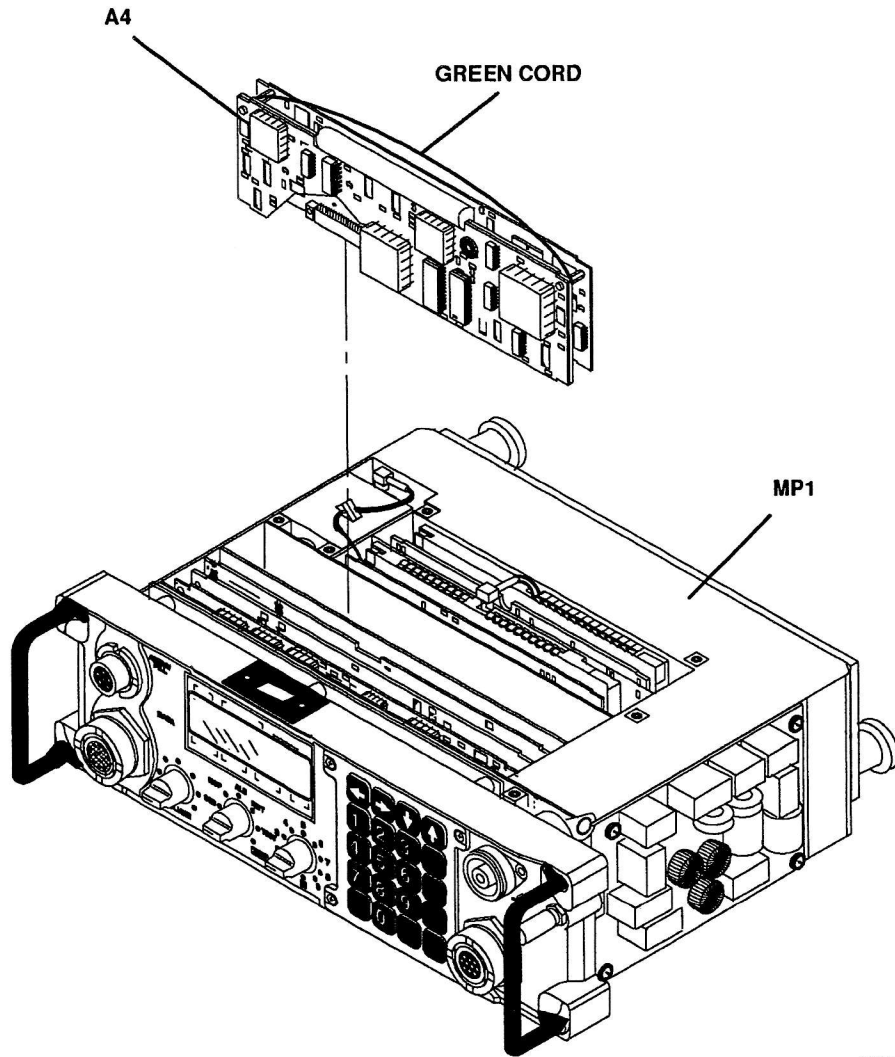

1694-012

Figure 6-6. A4 Signal Processor PWB Assembly Connector and Hardware Locations

6.5.6 A5 Receiver/Exciter Assembly Removal and Replacement

The following paragraphs provide instructions for the removal and replacement of the A5 Receiver/Exciter Assembly from the receiver-transmitter. See Figure 6-7.

WARNING

To prevent electrical shock and RF burns, remove all electrical connections to the receiver-transmitter before removing and replacing assemblies.



Some components on the A5 Receiver/Exciter Assembly can be damaged by static discharge. Failure to take the proper precautions may damage the assembly. For more information, refer to the Safety Summary at the beginning of this manual.

6.5.6.1 A5 Receiver/Exciter Assembly Removal

Perform the following procedure to remove the A5 Receiver/Exciter Assembly from the receiver-transmitter chassis:

- a. Remove MP2 Radio Case and Gasket Assembly per Paragraph 6.5.1.1.
- b. Remove MP3 PWB Compartment Cover Assembly per Paragraph 6.5.2.1.
- c. Remove A5A2P8 coaxial cable from under MP30 spring finger strip.
- d. Use needle-nose pliers (Item 5) to disconnect A5A2P8 coaxial cable from W2P2 connector.
- e. Use needle-nose pliers (Item 5) to disconnect A6A2W1J1 coaxial cable from A5A2J2 connector.
- f. Remove the A5 Receiver/Exciter Assembly from MP1 chassis by grasping the green cord and pulling upward.

6.5.6.2 A5 Receiver/Exciter Assembly Replacement

Perform the following procedure to replace the A5 Receiver/Exciter Assembly into the receiver-transmitter chassis:

- a. Slide the A5 Receiver/Exciter Assembly into the empty slot in MP1 chassis and push downward.
- b. Connect A5A2P8 coaxial cable to W2P2 connector.
- c. Position A5A2P8 coaxial cable under MP30 spring finger strip.
- d. Connect A6A2W1J1 coaxial cable to A5A2J2 connector.
- e. Replace MP3 PWB Compartment Cover Assembly per Paragraph 6.5.2.2.
- f. Replace MP2 Radio Case and Gasket Assembly per Refer to Paragraph 6.5.1.2.

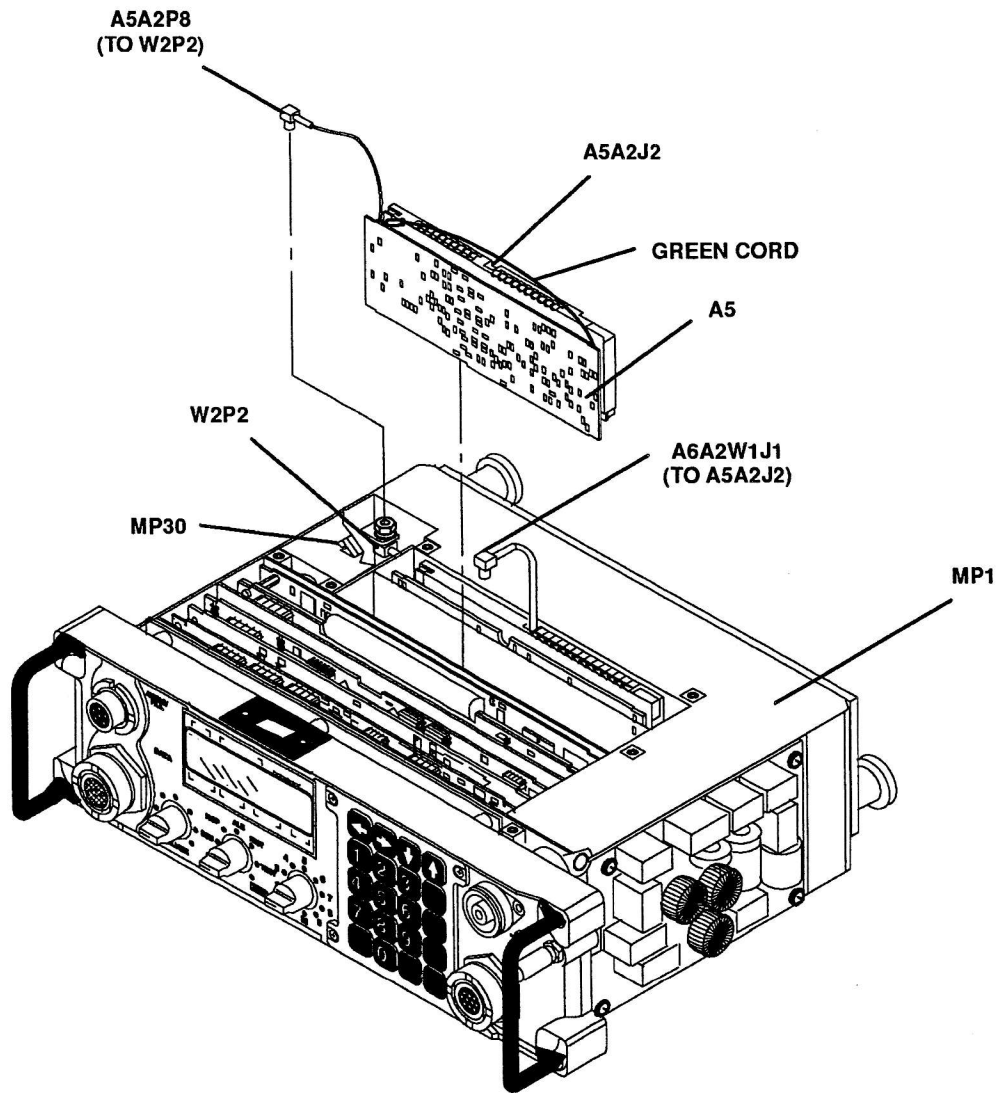

1694-013

Figure 6-7. A5 Receiver/Exciter Assembly Connector and Hardware Locations

6.5.7 A6 Synthesizer Assembly Removal and Replacement

The following paragraphs provide instructions for the removal and replacement of the A6 Synthesizer Assembly from the receiver-transmitter. See Figure 6-8.

WARNING

To prevent electrical shock and RF burns, remove all electrical connections to the receiver-transmitter before removing and replacing assemblies.



Some components on the A6 Synthesizer Assembly can be damaged by static discharge. Failure to take the proper precautions may damage the assembly. For more information, refer to the Safety Summary at the beginning of this manual.

6.5.7.1 A6 Synthesizer Assembly Removal

Perform the following procedure to remove the A6 Synthesizer Assembly from the receiver-transmitter chassis:

- a. Remove MP2 Radio Case and Gasket Assembly per Paragraph 6.5.1.1.
- b. Remove MP3 PWB Compartment Cover Assembly per Paragraph 6.5.2.1.
- c. Use needle-nose pliers (Item 5) to disconnect A6A2W1J1 coaxial cable from A5A2J2 connector.
- d. Remove the A6 Synthesizer Assembly from MP1 chassis by grasping the green cord and pulling upward.
- e. Remove the MP26 rubber pad from MP1 chassis.

6.5.7.2 A6 Synthesizer Assembly Replacement

Perform the following procedure to replace the A6 Synthesizer Assembly into the receiver-transmitter chassis:

- a. Slide the A6 Synthesizer Assembly into the empty slot in MP1 chassis and push downward.
- b. Slide the MP26 rubber pad between MP1 chassis and the A6 Synthesizer Assembly.
- c. Connect A6A2W1J1 coaxial cable to A5A2J2 connector.
- d. Replace MP3 PWB Compartment Cover Assembly per Paragraph 6.5.2.2.
- e. Replace MP2 Radio Case and Gasket Assembly per Paragraph 6.5.1.2.

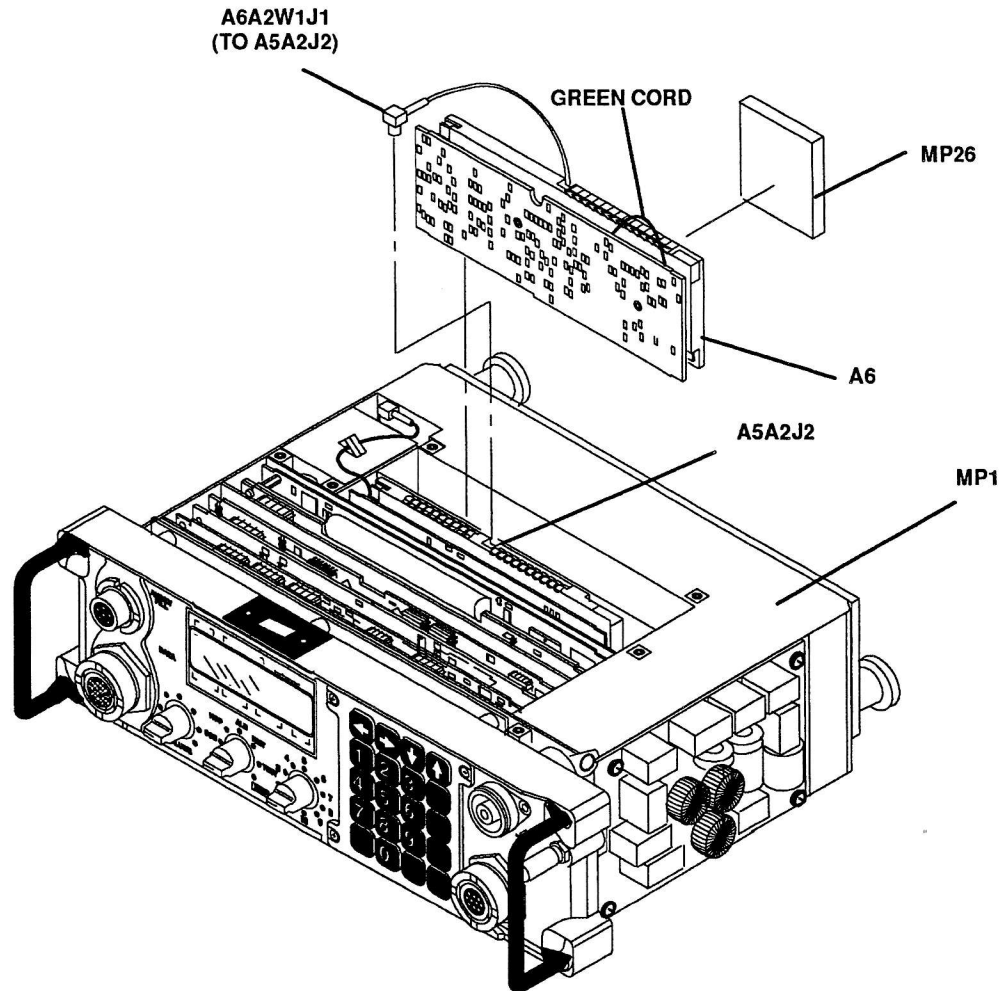

1694-014

Figure 6-8. A6 Synthesizer Assembly Connector and Hardware Locations

6.5.8 A7 Power Supply Assembly Removal and Replacement

The following paragraphs provide instructions for the removal and replacement of the A7 Power Supply Assembly from the receiver-transmitter. See Figure 6-9.

WARNING

To prevent electrical shock and RF burns, remove all electrical connections to the receiver-transmitter before removing and replacing assemblies.

CAUTION



Some components on the A7 Power Supply Assembly can be damaged by static discharge. Failure to take the proper precautions may damage the assembly. For more information, refer to the Safety Summary at the beginning of this manual.

6.5.8.1 A7 Power Supply Assembly Removal

Perform the following procedure to remove the A7 Power Supply Assembly from the receiver-transmitter chassis:

- a. Remove MP2 Radio Case and Gasket Assembly per Paragraph 6.5.1.1.
- b. Remove MP3 PWB Compartment Cover Assembly per Paragraph 6.5.2.1.
- c. Remove A5A2P8 coaxial cable from under MP30 spring finger strip. Position A5A2P8 cable so that it is not blocking the A7 Power Supply Assembly.
- d. From bottom of MP1 chassis, use a cross-tip screwdriver (Item 1) to remove the three (3) screws (D), lockwashers (E), and flatwashers (H) that secure the A7 Power Supply Assembly to the the A11 PWB Assembly.
- e. Remove the A7 Power Supply Assembly from MP1 chassis by grasping the assembly and pulling upward.

6.5.8.2 A7 Power Supply Assembly Replacement

Perform the following procedure to replace the A7 Power Supply Assembly into the receiver-transmitter chassis:

- a. Slide the A7 Power Supply Assembly into the empty slot in MP1 chassis and push downward to seat the connector to the A11 PWB Assembly.
- b. From bottom of MP1 chassis, use a cross-tip screwdriver (Item 1) to replace the three (3) screws (D), lockwashers (E), and flatwashers (H) that secure the A7 Power Supply Assembly to MP1 chassis.
- c. Replace A5A2P8 coaxial cable under MP30 spring finger strip.
- d. Replace MP3 PWB Compartment Cover Assembly per Paragraph 6.5.2.2.
- e. Replace MP2 Radio Case and Gasket Assembly per Paragraph 6.5.1.2.

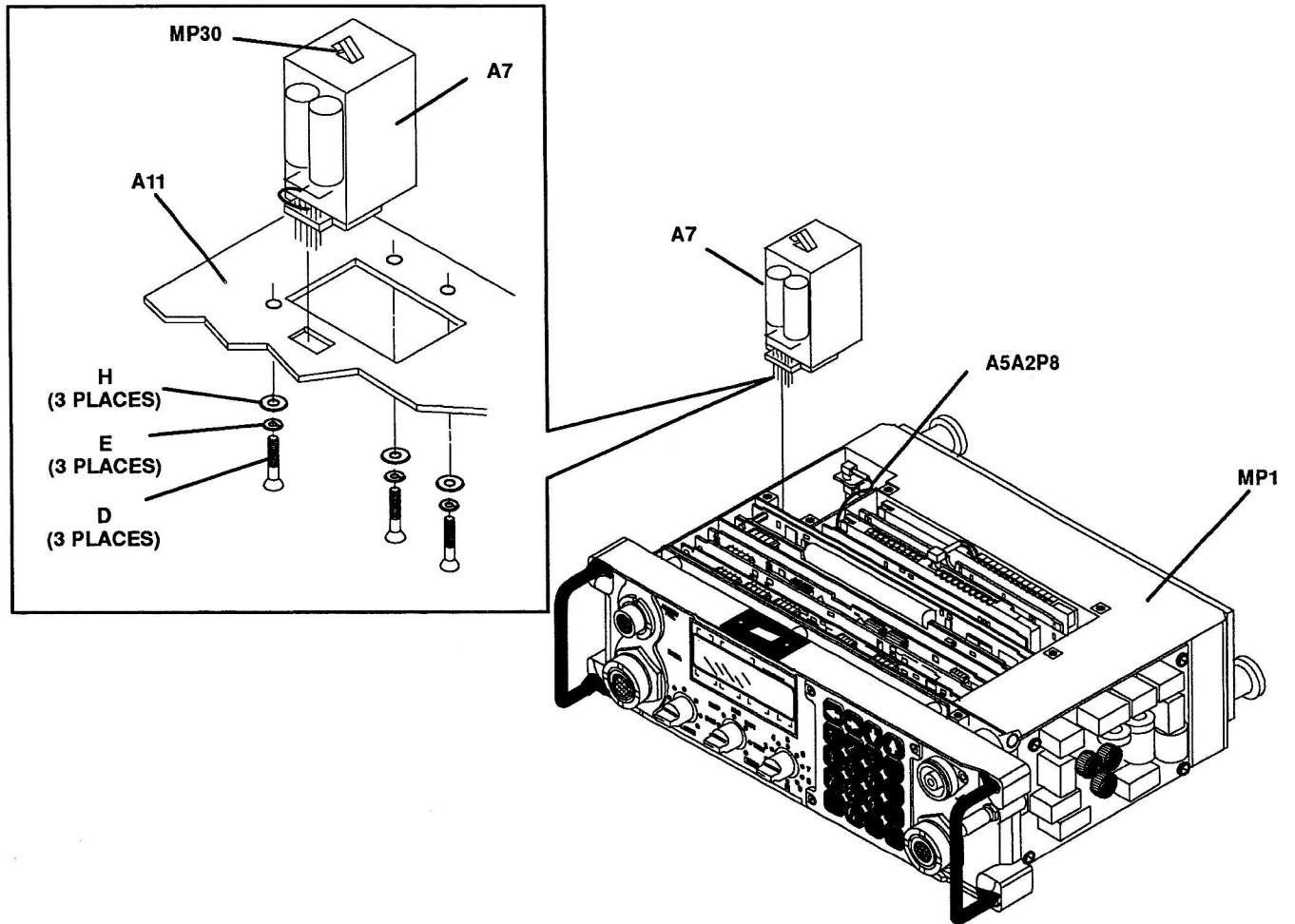

1694-015A

Figure 6-9. A7 Power Supply Assembly Connector and Hardware Locations

6.5.9 A8 PA/Battery Charger Assembly Removal and Replacement

The following paragraphs provide instructions for the removal and replacement of the A8 PA/Battery Charger Assembly from the receiver-transmitter. See Figure 6-10.

WARNING

To prevent electrical shock and RF burns, remove all electrical connections to the receiver-transmitter before removing and replacing assemblies.



Some components on the A8 PA/Battery Charger Assembly can be damaged by static discharge. Failure to take the proper precautions may damage the assembly. For more information, refer to the Safety Summary at the beginning of this manual.

6.5.9.1 A8 PA/Battery Charger Assembly Removal

Perform the following procedure to remove the A8 PA/Battery Charger Assembly from the receiver-transmitter chassis:

- a. Remove MP2 Radio Case and Gasket Assembly per Paragraph 6.5.1.1.

NOTE

Fuses A8F1 and A8F3 can be removed and replaced without removing the A8 PA/Battery Charger Assembly from MP1 chassis. Use needle-nose pliers (Item 5) to remove and replace the fuses through the holes in the rear of the A8 PA/Battery Charger Assembly. See Figure 6-10.

- b. Remove MP3 PWB Compartment Cover Assembly per Paragraph 6.5.2.1.
- c. Disconnect ribbon cable A11P1 from A8A1P1.
- d. Disconnect coaxial cable W1P1 from A8A2J3.
- e. Use a cross-tip screwdriver (Item 2) to loosen the four (4) captive screws that secure the A8 PA/Battery Charger Assembly to MP1 chassis.

- f. Pull the A8 PA/Battery Charger Assembly away from MP1 chassis.



Do not overextend W2 Coaxial Cable Assembly.

- g. Disconnect coaxial cable W2P1 from A8A1J2.
- h. Remove the A8 PA/Battery Charger Assembly from MP1 chassis.

6.5.9.2 A8 PA/Battery Charger Assembly Replacement

Perform the following procedure to replace the A8 PA/Battery Charger Assembly into the receiver-transmitter chassis:

- a. Position the A8 PA/Battery Charger Assembly near MP1 chassis.
- b. Connect coaxial cable W2P1 to A8A1J2.
- c. Use a cross-tip screwdriver (Item 2) to tighten the four (4) captive screws that secure the A8 PA/Battery Charger Assembly to MP1 chassis.
- d. Connect ribbon cable A11P1 to A8A1P1.
- e. Connect coaxial cable W1P1 to A8A2J3.
- f. Replace MP3 PWB Compartment Cover Assembly per Paragraph 6.5.2.2.
- g. Replace MP2 Radio Case and Gasket Assembly per Paragraph 6.5.1.2.

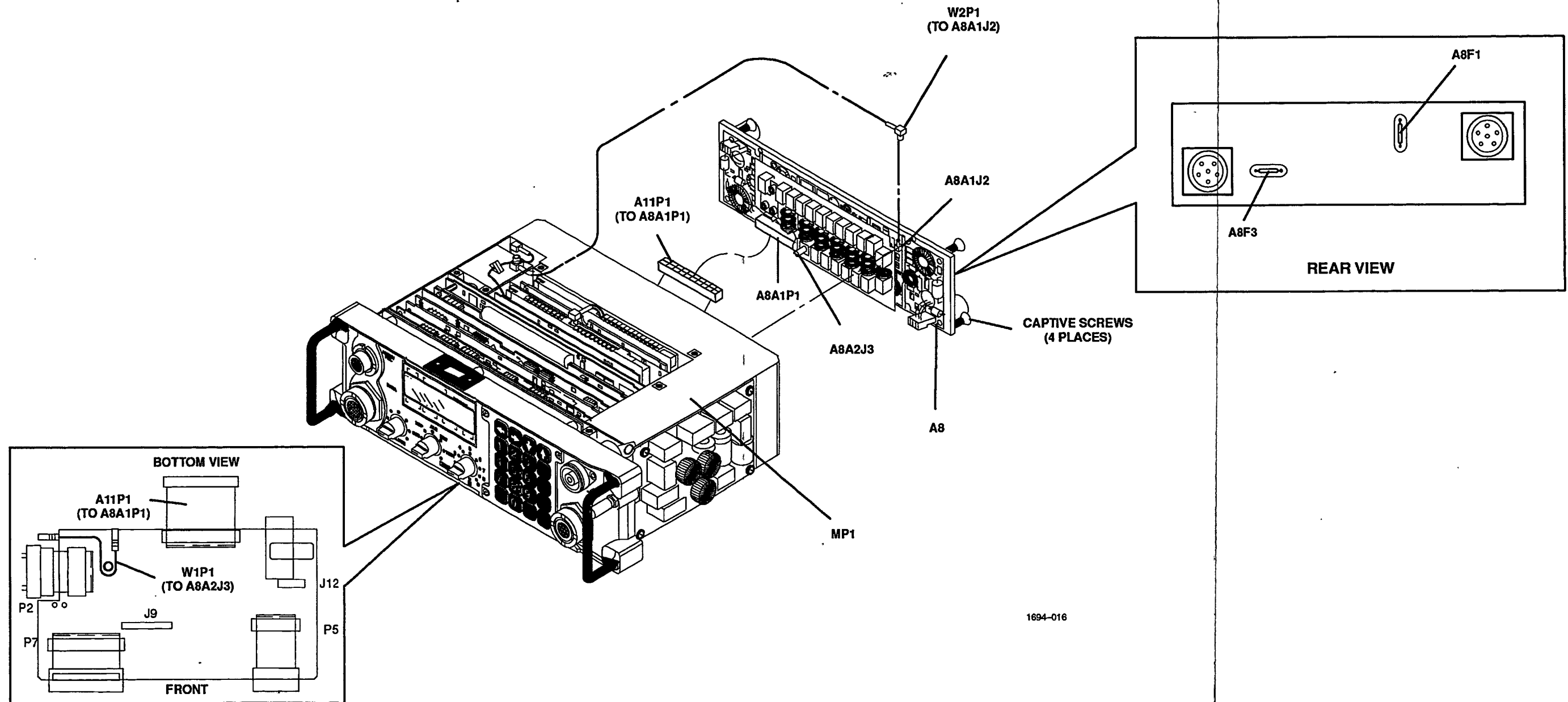

Figure 6-10. A8 PA/Battery Charger Assembly Connector and Hardware Locations

6.5.10 A9 Antenna Coupler Assembly Removal and Replacement

The following paragraphs provide instructions for the removal and replacement of the A9 Antenna Coupler Assembly from the receiver-transmitter. See Figure 6-11.

WARNING

To prevent electrical shock and RF burns, remove all electrical connections to the receiver-transmitter before removing and replacing assemblies.



Some components on the A9 Antenna Coupler Assembly can be damaged by static discharge. Failure to take the proper precautions may damage the assembly. For more information, refer to the Safety Summary at the beginning of this manual.

6.5.10.1 A9 Antenna Coupler Assembly Removal

Perform the following procedure to remove the A9 Antenna Coupler Assembly from the receiver-transmitter chassis:

- a. Remove MP2 Radio Case and Gasket Assembly per Paragraph 6.5.1.1.
- b. Remove MP3 PWB Compartment Cover Assembly per Paragraph 6.5.2.1.
- c. Disconnect ribbon cable A11P2 from A9A1P1.
- d. Disconnect coaxial cable W1P2 from A9A1J2.
- e. Use a cross-tip screwdriver (Item 2) to loosen and remove the screw (P), lockwasher (Q), and flatwasher (R) that secure the antenna connecting lug from the antenna connector to the A9 Antenna Coupler Assembly.
- f. Use a cross-tip screwdriver (Item 3) to loosen and remove the two screws (A) that secure the right side of the A10 Front Panel Assembly to chassis MP1.
- g. Use a cross-tip screwdriver (Item 2) to loosen the four (4) captive screws that secure the A9 Antenna Coupler Assembly to MP1 chassis.
- h. Pull the right side of the front panel away from the chassis, so the antenna connecting lug clears the A9 Antenna Coupler Assembly and remove A9 assembly from MP1 chassis.

6.5.10.2 A9 Antenna Coupler Assembly Replacement

Perform the following procedure to replace the A9 Antenna Coupler Assembly into the receiver-transmitter chassis:

- a. Position the A9 Antenna Coupler Assembly into position against MP1 chassis.

NOTE

Make sure the A9 Antenna Coupler Assembly is positioned behind the antenna connecting lug from the front panel antenna connector.

- b. Use a cross-tip screwdriver (Item 2) to tighten the four (4) captive screws that secure the A9 Antenna Coupler Assembly to MP1 chassis.
- c. Use a cross-tip screwdriver (Item 3) to install and tighten the two screws (A) that secure the right side of the A10 Front Panel Assembly to chassis MP1.
- d. Use a cross-tip screwdriver (Item 2) to install and tighten the screw (P), lockwasher (Q), and flatwasher (R) that secure the antenna connecting lug from the antenna connector to the A9 Antenna Coupler Assembly.
- e. Connect ribbon cable A11P2 to A9A1P1.
- f. Connect coaxial cable W1P2 to A9A1J2.
- g. Replace MP3 PWB Compartment Cover Assembly per Paragraph 6.5.2.2.
- h. Replace MP2 Radio Case and Gasket Assembly per Paragraph 6.5.1.2.

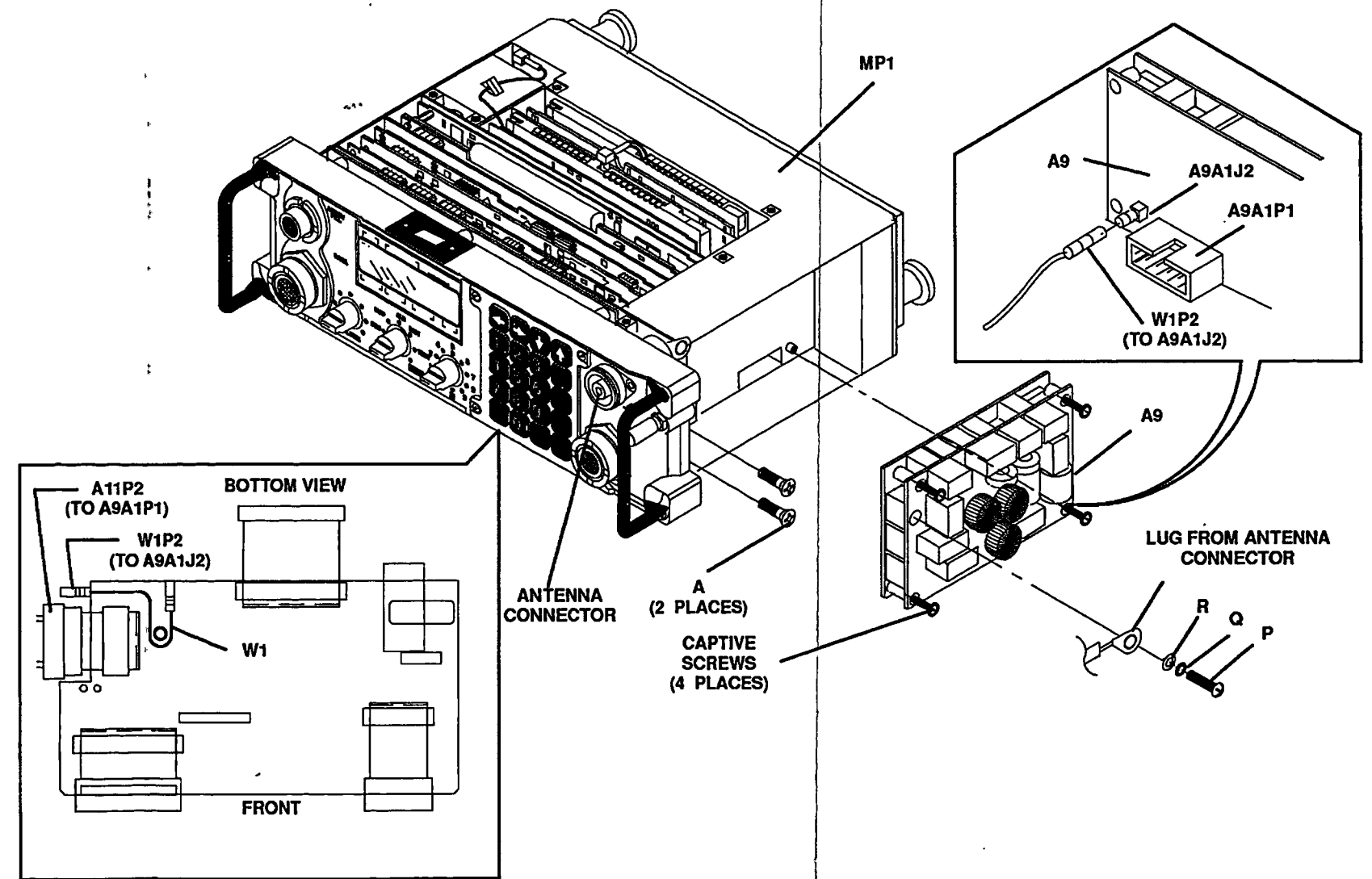

Figure 6-11. A9 Antenna Coupler Assembly Connector and Hardware Locations

6.5.11 A10 Front Panel Assembly Removal and Replacement

The following paragraphs provide instructions for the removal and replacement of the A10 Front Panel Assembly from the receiver-transmitter. See Figure 6-12.

WARNING

To prevent electrical shock and RF burns, remove all electrical connections to the receiver-transmitter before removing and replacing assemblies.

CAUTION



Some components on the A10 Front Panel Assembly can be damaged by static discharge. Failure to take the proper precautions may damage the assembly. For more information, refer to the Safety Summary at the beginning of this manual.

6.5.11.1 A10 Front Panel Assembly Removal

Perform the following procedure to remove the A10 Front Panel Assembly from the receiver-transmitter chassis:

- a. Remove MP2 Radio Case and Gasket Assembly per Paragraph 6.5.1.1.
- b. Disconnect ribbon cable A11P5 from A10A1J5.
- c. Disconnect ribbon cable A11P7 from A10A1J7.
- d. Use a cross-tip screwdriver (Item 2) to loosen and remove the screw (P), lockwasher (Q), and flatwasher (R) that secure the antenna connecting lug from the antenna connector to the A9 Antenna Coupler Assembly.
- e. Use a cross-tip screwdriver (Item 3) to remove four (4) screws (A) that secure the A10 Front Panel Assembly to MP1 chassis.
- f. Remove the A10 Front Panel Assembly from MP1 chassis.

6.5.11.2 A10 Front Panel Assembly Replacement

Perform the following procedure to replace the A10 Front Panel Assembly onto the receiver-transmitter chassis:

- a. Position the A10 Front Panel Assembly against MP1 chassis.

NOTE

Make sure the antenna connecting lug from the front panel antenna connector is positioned over the related hardware mounting hole in the A9 Antenna Coupler Assembly.

- b. Use a cross-tip screwdriver (Item 3) to install the four (4) screws (A) that secure the A10 Front Panel Assembly to MP1 chassis.
- c. Use a cross-tip screwdriver (Item 2) to install and tighten the screw (P), lockwasher (Q), and flatwasher (R) that secure the antenna connecting lug from the antenna connector to the A9 Antenna Coupler Assembly.
- d. Connect ribbon cable A11P5 to A10A1J5.
- e. Connect ribbon cable A11P7 to A10A1J7.
- f. Replace MP2 Radio Case and Gasket Assembly per Paragraph 6.5.1.2.

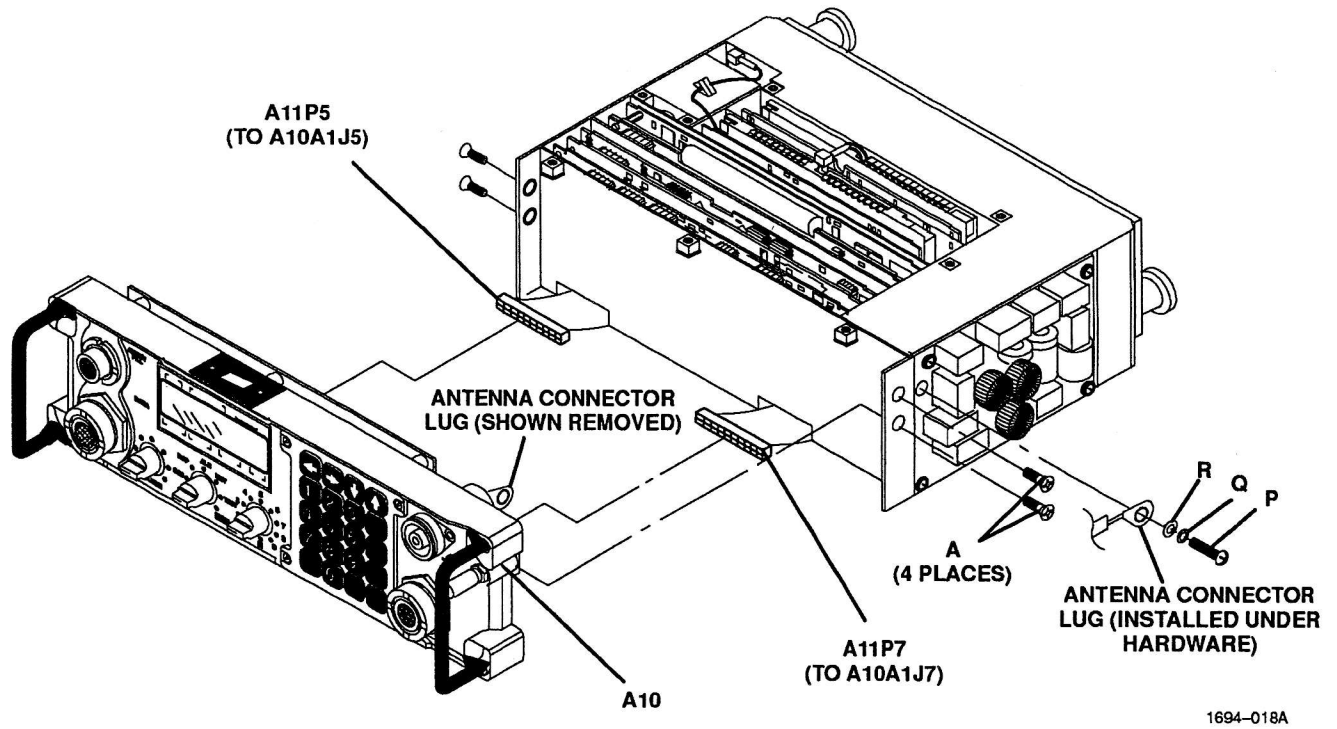

Figure 6-12. A10 Front Panel Assembly Connector and Hardware Locations

6.5.12 A11 Motherboard Assembly Removal and Replacement

The following paragraphs provide instructions for the removal and replacement of the A11 Motherboard Assembly from the receiver-transmitter. See Figure 6-13.

WARNING

To prevent electrical shock and RF burns, remove all electrical connections to the receiver-transmitter before removing and replacing assemblies.



Some components on the A11 Motherboard Assembly can be damaged by static discharge. Failure to take the proper precautions may damage the assembly. For more information, refer to the Safety Summary at the beginning of this manual.

6.5.12.1 A11 Motherboard Assembly Removal

Perform the following procedure to remove the A11 Motherboard Assembly from the receiver-transmitter chassis:

- a. Remove MP2 Radio Case and Gasket Assembly per Paragraph 6.5.1.1.
- b. Remove MP3 PWB Compartment Cover Assembly per Paragraph 6.5.2.1.
- c. Remove the A1A1 Interface PWB Assembly and A1A2 Interface PWB Assembly (if installed) from MP1 chassis per Paragraph 6.5.3.1.
- d. Remove the A3 LPC Vocoder Assembly (if installed) from MP1 chassis. Refer to Paragraph 6.5.4.1.
- e. Remove the A4 Signal Processor PWB Assembly from MP1 chassis per Paragraph 6.5.5.1.
- f. Remove the A5 Receiver/Exciter Assembly from MP1 chassis per Paragraph 6.5.6.1.
- g. Remove the A6 Synthesizer Assembly from MP1 chassis per Paragraph 6.5.7.1.
- h. Remove the A7 Power Supply Assembly from MP1 chassis per Paragraph 6.5.8.1.
- i. Remove W1 Coaxial Cable Assembly per Paragraph 6.5.13.1.
- j. Disconnect ribbon cable A11P1 from A8A1P1.
- k. Disconnect ribbon cable A11P2 from A9A1P1.
- l. Disconnect ribbon cable A11P7 from A10A1J7.
- m. Disconnect ribbon cable A11P5 from A10A1J5.

- n. Use a socket wrench and handle (Items 6 and 7) to remove the five (5) hex spacers (C) and flatwashers (F) that secure the A11 Motherboard Assembly to MP1 chassis.
- o. Remove the A11 Motherboard Assembly from MP1 chassis.

6.5.12.2 A11 Motherboard Assembly Replacement

Perform the following procedure to replace the A11 Motherboard Assembly into the receiver-transmitter chassis:

- a. Position the A11 Motherboard Assembly into MP1 chassis.
- b. Use a socket wrench and handle (Items 6 and 7) to install the five (5) hex spacers (C) and flatwashers (F) that secure the A11 Motherboard Assembly to MP1 chassis.
- c. Connect ribbon cable A11P1 to A8A1P1.
- d. Connect ribbon cable A11P2 to A9A1P1.
- e. Connect ribbon cable A11P7 to A10A1J7.
- f. Connect ribbon cable A11P5 to A10A1J5.
- g. Replace W1 Coaxial Cable Assembly per Refer to Paragraph 6.5.13.2.
- h. Replace the A1A1 Interface PWB Assembly and A1A2 Interface PWB Assembly (if part of the receiver-transmitter configuration) into MP1 chassis per Paragraph 6.5.3.2.
- i. Replace the A3 LPC Vocoder Assembly (if part of the receiver-transmitter configuration) into MP1 chassis per Paragraph 6.5.4.2.
- j. Replace the A4 Signal Processor PWB Assembly into MP1 chassis per Paragraph 6.5.5.2.
- k. Replace the A5 Receiver/Exciter Assembly into MP1 chassis per Paragraph 6.5.6.2.
- l. Replace the A6 Synthesizer Assembly into MP1 chassis per Paragraph 6.5.7.2.
- m. Replace the A7 Power Supply Assembly into MP1 chassis per Paragraph 6.5.8.2.
- n. Replace MP3 PWB Compartment Cover Assembly per Paragraph 6.5.2.2.
- o. Replace MP2 Radio Case and Gasket Assembly per Paragraph 6.5.1.2.

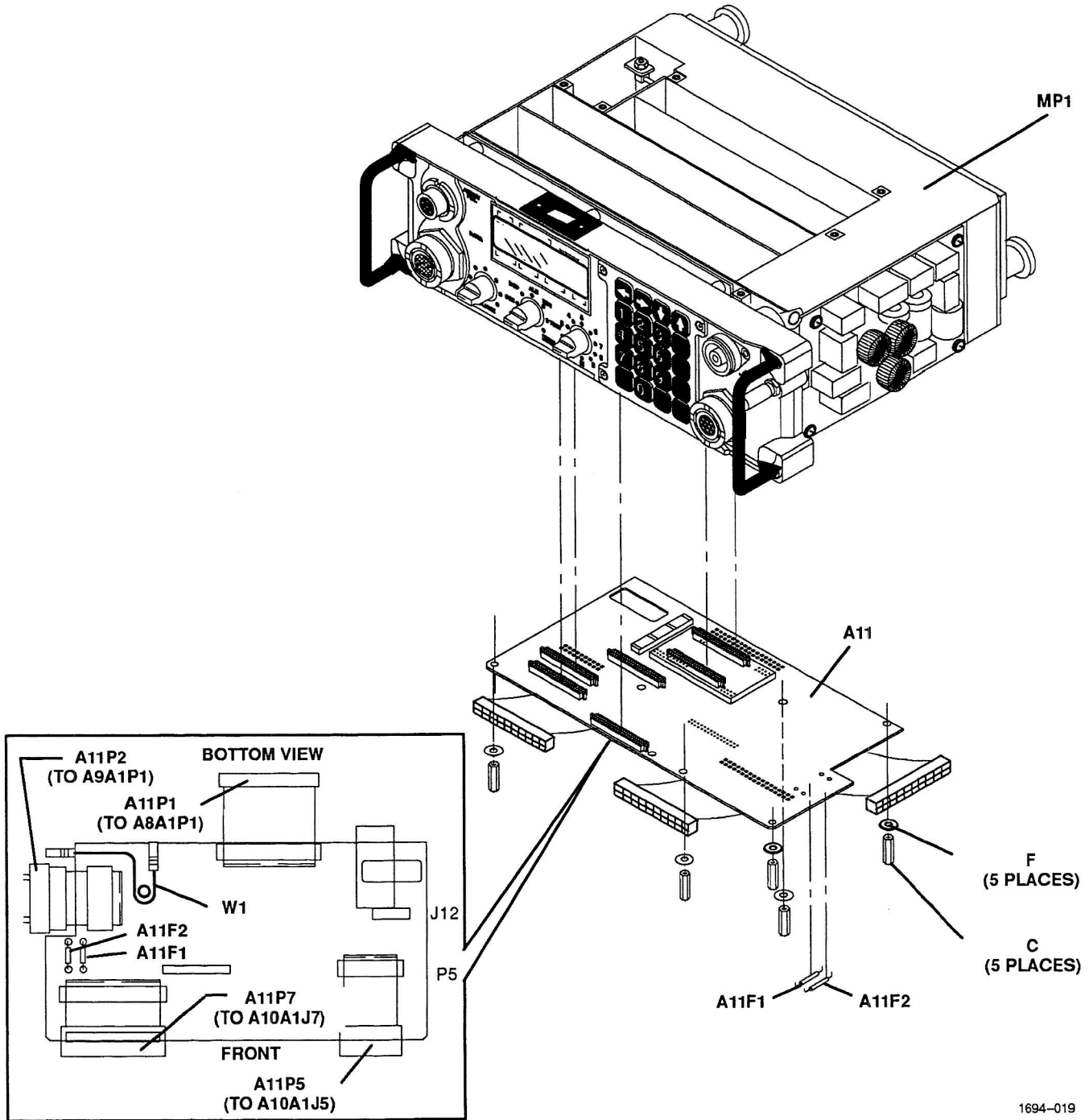

1694-019

Figure 6-13. A11 Motherboard Assembly Hardware and Connector Locations

6.5.13 W1 Coaxial Cable Assembly Removal and Replacement

The following paragraphs provide instructions for the removal and replacement of the W1 Coaxial Cable Assembly from the receiver-transmitter chassis. See Figure 6-14.

WARNING

To prevent electrical shock and RF burns, remove all electrical connections to the receiver-transmitter before removing and replacing assemblies.

6.5.13.1 W1 Coaxial Cable Assembly Removal

Perform the following procedure to remove the W1 Coaxial Cable Assembly from the receiver-transmitter chassis:

- a. Remove MP2 Radio Case and Gasket Assembly per Paragraph 6.5.1.1.
- b. Disconnect W1P1 from A8A2J3.
- c. Disconnect W1P2 from A9A1J2.
- d. Remove the W1 Coaxial Cable Assembly from MP1 chassis.

6.5.13.2 W1 Coaxial Cable Assembly Replacement

Perform the following procedure to replace the W1 Coaxial Cable Assembly into the receiver-transmitter chassis:

- a. Position the W1 Coaxial Cable Assembly into MP1 chassis, dressing cable around standoff.
- b. Connect W1P1 to A8A2J3.
- c. Connect W1P2 to A9A1J2.
- d. Replace MP2 Radio Case and Gasket Assembly per Paragraph 6.5.1.2.

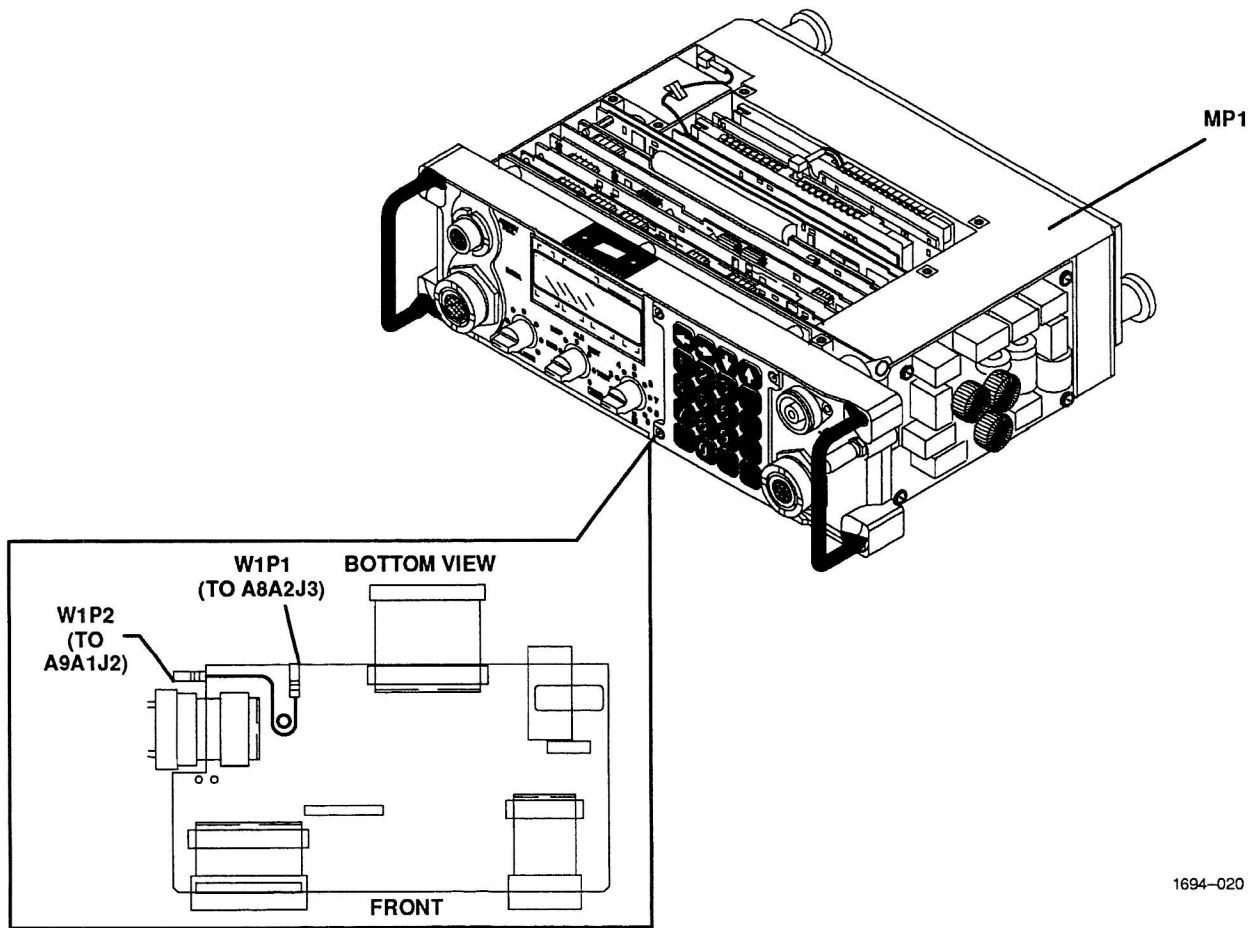

1694-020

Figure 6-14. W1 Coaxial Cable Assembly Removal and Replacement

6.5.14 W2 Coaxial Cable Assembly Removal and Replacement

The following paragraphs provide instructions for the removal and replacement of the W2 Coaxial Cable Assembly from the receiver-transmitter. See Figure 6-15.

WARNING

To prevent electrical shock and RF burns, remove all electrical connections to the receiver-transmitter before removing and replacing assemblies.

6.5.14.1 W2 Coaxial Cable Assembly Removal

Perform the following procedure to remove the W2 Coaxial Cable Assembly from the receiver-transmitter chassis:

- a. Remove MP2 Radio Case and Gasket Assembly per Paragraph 6.5.1.1.
- b. Remove MP3 PWB Compartment Cover Assembly per Paragraph 6.5.2.1.
- c. Remove A8 PA/Battery Charger Assembly per Paragraph 6.5.9.1.
- d. Use needle-nose pliers (Item 5) to disconnect A5A2P8 coaxial cable from W2P2 connector.
- e. Use a socket wrench and handle (Items 6 and 7) to remove the nut and washer that secure W2P2 to MP1 chassis.
- f. Pull W2P2 connector through hole in MP1 chassis and remove from chassis.

6.5.14.2 W2 Coaxial Cable Assembly Replacement

Perform the following procedure to replace the W2 Coaxial Cable Assembly into the receiver-transmitter chassis:

- a. Feed W2P2 connector through hole in MP1 chassis.
- b. Use a socket wrench and handle (Items 6 and 7) to tighten the nut and washer that secure W2P2 connector to MP1 chassis.
- c. Connect A5A2P8 coaxial cable to W2P2 connector.
- d. Replace the A8 PA/Battery Charger Assembly per Paragraph 6.5.9.2.
- e. Replace MP3 PWB Compartment Cover Assembly per Paragraph 6.5.2.2.
- f. Replace MP2 Radio Case and Gasket Assembly per Paragraph 6.5.1.2.

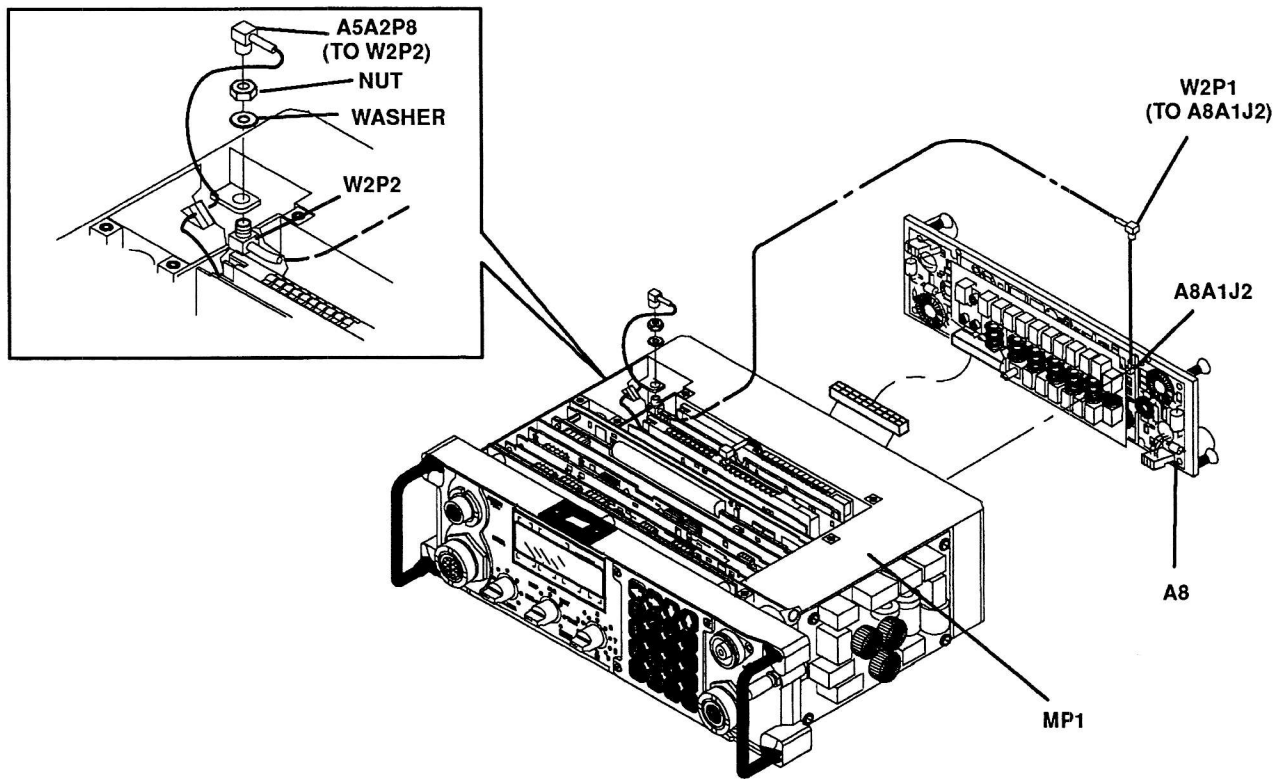

1694-021

Figure 6-15. W2 Coaxial Cable Assembly Removal and Replacement

CHAPTER 7

PARTS LIST

7.1 INTRODUCTION

This chapter contains receiver-transmitter parts list information. This information can be used to identify parts within the receiver-transmitter and to place orders for those parts. This chapter is organized as follows:

- Paragraph 7.2 – Shop Replaceable Units
- Paragraph 7.3 – Parts Lists
- Paragraph 7.4 – Component Location and Assembly Diagrams

7.2 SHOP REPLACEABLE UNITS

Figure 7-1 shows the locations of the Shop Replaceable Units (SRUs). Table 7-1 lists the SRUs that make up the receiver-transmitter. The quantity, part number, manufacturer of the SRU, and component location figure numbers are provided. Items that do not have a component location diagram are cross-referenced to an illustration that shows the relative position of the SRU within the receiver-transmitter.

Table 7-1. List of Shop Replaceable Units

Reference Designation	Item Name	Quantity Per Unit	Part Number	Cage Code	Figure Number
A1A1	Interface Printed Wiring Board (PWB) Assembly	1	10303-2280	14304	7-2
A1A2	Encryption PWB Assembly (RT-1694(P) configuration only)	1	10303-2240	14304	7-3
A3	Linear Predictive Coding (LPC) Vocoder Assembly (Standard on RT-1694A(P) and RT-1694B(P)/U configurations)	1	10372-3440-01	14304	7-4
A4	Signal Processor PWB Assembly	1	10303-2500 or 10530-2500-01	14304	7-5, 7-6
A5	Receiver/Exciter Assembly	1	10303-2600-02	14304	7-7, 7-8
A6	Synthesizer Assembly	1	10303-2700	14304	7-9, 7-10
A7	Power Supply Assembly	1	10303-2200	14304	7-11
A8	Power Amplifier (PA)/Battery Charger Assembly	1	10372-1400-01 or 10530-1400-01	14304	7-12, 7-13, 7-14
A9	Antenna Coupler Assembly	1	10372-1450-01	14304	7-15
A10	Front Panel Assembly	1	10372-1500-01/02 or 10530-1500-01	14304	7-16
A11	Motherboard Assembly	1	10303-2170	14304	7-17
W1	PA-Coupler RF Cable Assembly	1	10372-1037-01	14304	7-18
W2	PA-Receiver/Exciter RF Cable Assembly	1	10372-1053-01	14304	7-19

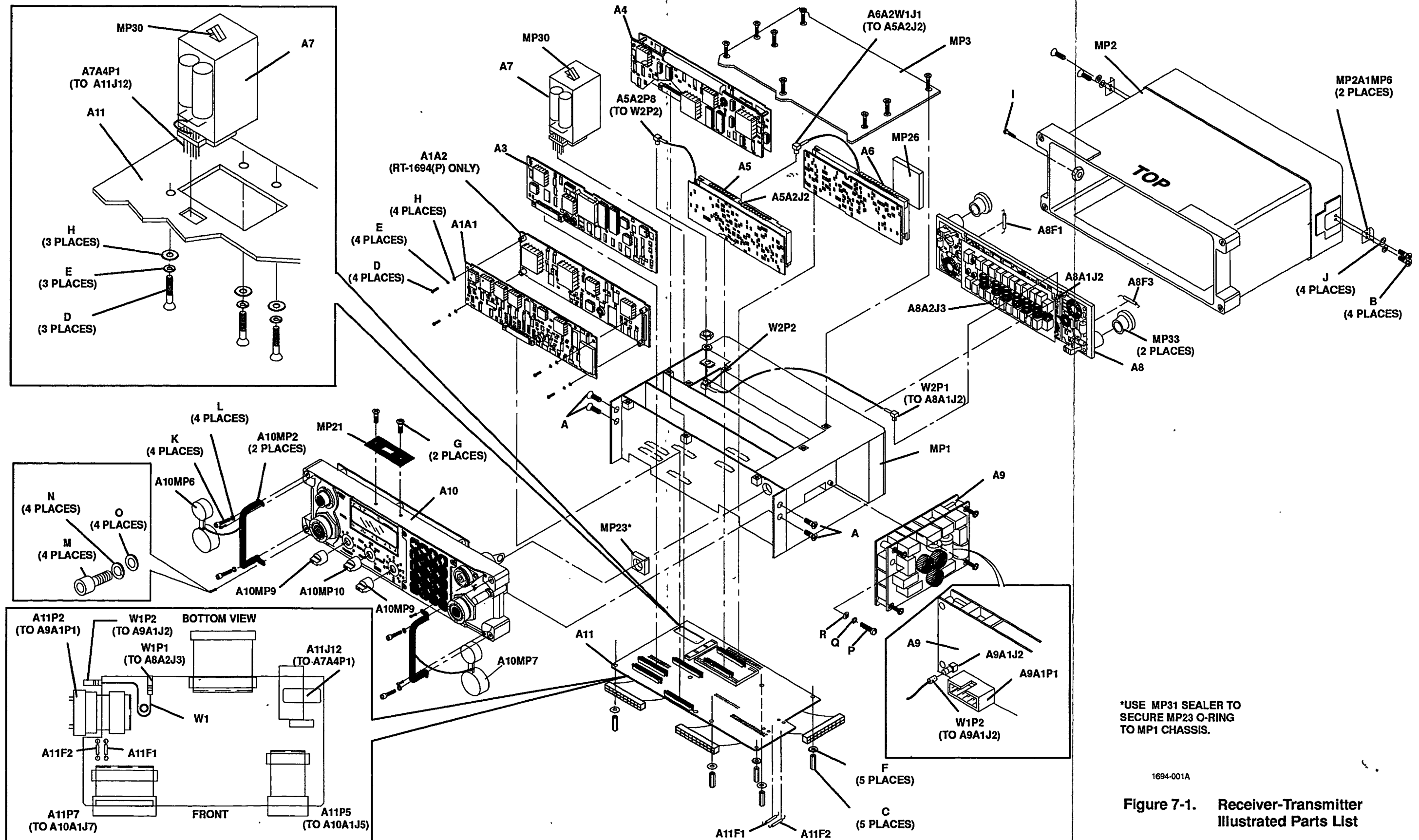

*USE MP31 SEALER TO SECURE MP23 O-RING TO MP1 CHASSIS.

1694-001A

Figure 7-1. Receiver-Transmitter Illustrated Parts List

7.3 PARTS LISTS

Table 7-2 provides a list of miscellaneous receiver-transmitter items. These are items called out in a Chapter 6 procedure, removed and replaced during maintenance, or that can be damaged or lost. Reference designators, part numbers, and manufacturer of the items are listed. These miscellaneous items are also identified in Figure 7-1.

Table 7-3 lists the receiver-transmitter attaching hardware. The letter codes provided are referenced by the procedures found in Chapter 6. Item names, characteristics, part numbers, and manufacturers are also provided. These attaching hardware items are also identified in Figure 7-1.

Table 7-2. Miscellaneous Items Parts List

Ref. Des.	Item Name	Part Number	Cage Code
A8F1	Fuse 7 A, 125 V	F15-0001-015	14304
A8F3	Fuse 7 A, 125 V	F15-0001-015	14304
A10MP2	Handle	10372-1041-01	14304
A10MP6	Dust Cap	10372-1525-01	14304
A10MP7	Dust Cap	10372-1525-02	14304
A10MP9	Control Knob	10012-2021	14304
A10MP10	Control Knob	10243-2021	14304
A11F1	Fuse, 7 A, 125 V	F15-0001-015	14304
A11F2	Fuse, 2 A, QA	F15-0001-009	14304
MP1	Chassis	10372-1005-01 or 10530-1005-01	14304
MP2	Radio Case and Gasket Assembly	10372-1014-01/02	14304
MP2A1MP6	Strike, Black	Z04-0002-102	14304
MP3	PWB Compartment Cover Assembly	10372-1010-01 or 10530-1010-01	14304
MP21	ID/Serial Number Label Plate	10372-1077-01 or 10530-1077-01	14304
MP23	Conductive O-Ring	10372-1206-01	14304
MP26	Rubber Pad	10372-1061-01	14304
MP30	Spring Finger Strip	10372-1209-01	14304
MP31	3145 Clear RTV Sealer	P15-3145-001	14304
MP33	Dust Cap	MS90376-12R	96906

Table 7-3. List of Attaching Hardware

Letter Code	Item Name	Description	Part Number	Cage Code
A	Flat Head Screw	6-32 x 1/4 inch	MS24693-C24	96906
B	Pan Head Screw	Black, 6-32 x 1/4	MS51957-26B	96906
C	Hex Spacer	4-40 x 1/4 inch	H50-1006-404	14304
D	Pan Head Screw	2-56 x 1/4 inch	MS51957-3	96906
E	Lockwasher	#2	MS35338-134	96906
F	Flatwasher	.125 x .250 x .022	MS15795-803	96906
G	Pan Head Screw	Black, 2-56 x 3/16	MS51957-2B	96906
H	Flatwasher	#2	10303-3024	14304
I	Self-Sealing Screw	Pan head screw w/ O-ring	10372-1081-01	14304
J	Lockwasher	Black	MS35338-136B	96906
K	Hex Head Screw	Black, #10	10372-1076-01	14304
L	Flatwasher	Black, #10	MS15795-846B	96906
M	Hex Head Screw	Black, 4-40 x 1/4	MS16995-9B	96906
N	Lockwasher	Black, #4	MS35338-135B	96906
O	Flatwasher	Black, .125 x .250	MS15795-803B	96906
P	Pan Head Screw	Brass	H12-0002-103	14304
Q	Lockwasher	PLN BVGZ #4 x .025	H41-0002-002	14304
R	Flatwasher	Brass, .119 x .28 x .025	H40-0003-002	14304

7.4 COMPONENT LOCATION AND ASSEMBLY DIAGRAMS

Component location diagrams (Figures 7-2 through 7-19) are supplied for verification of assembly connectors and test points.

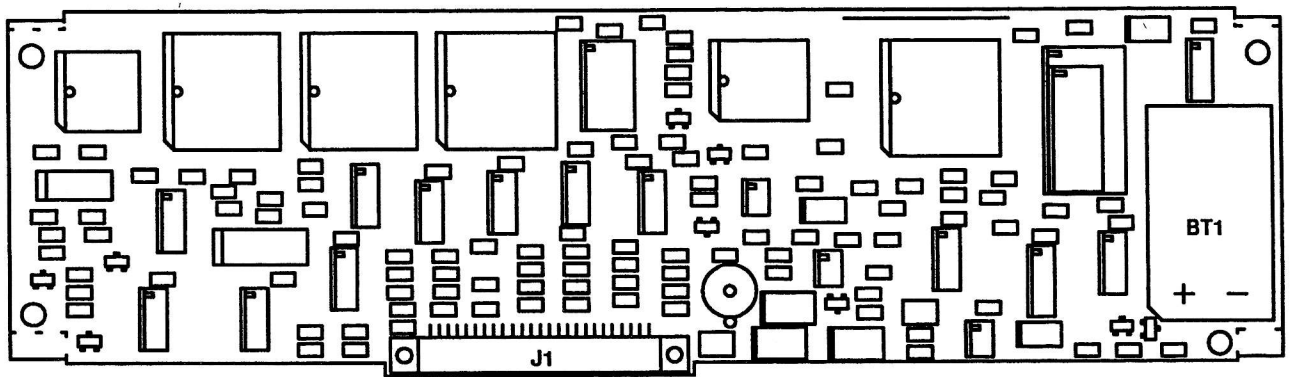

FRONT

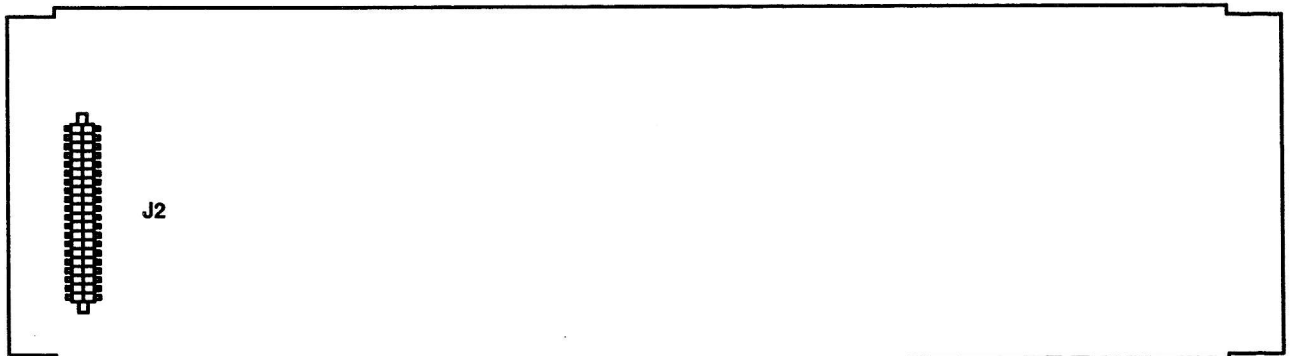

BACK

1694-039

**Figure 7-2. A1A1 Interface PWB Assembly Component Location Diagram
(10303-2280 Rev. A)**

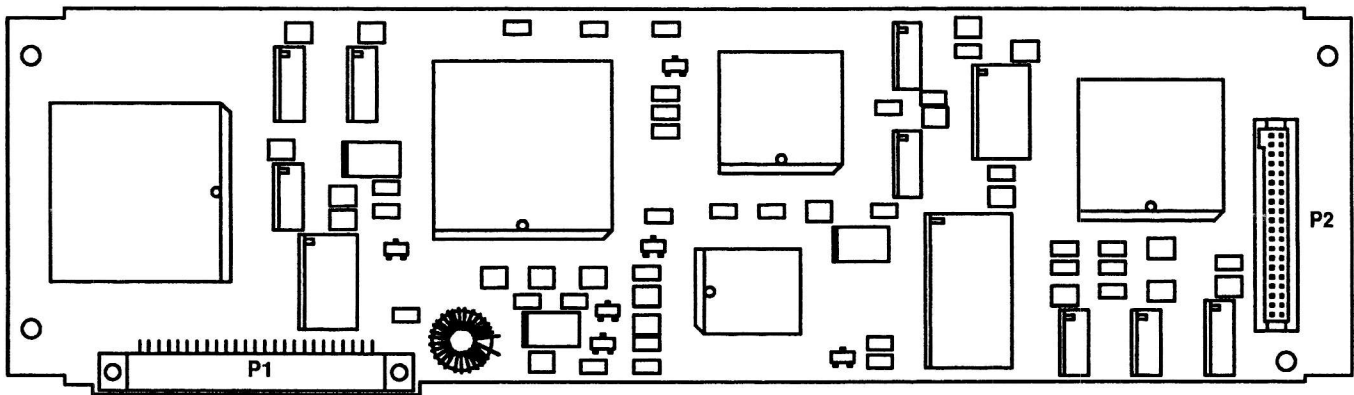

1694-040

Figure 7-3. A1A2 Encryption PWB Assembly Component Location Diagram (10303-2240 Rev. A)

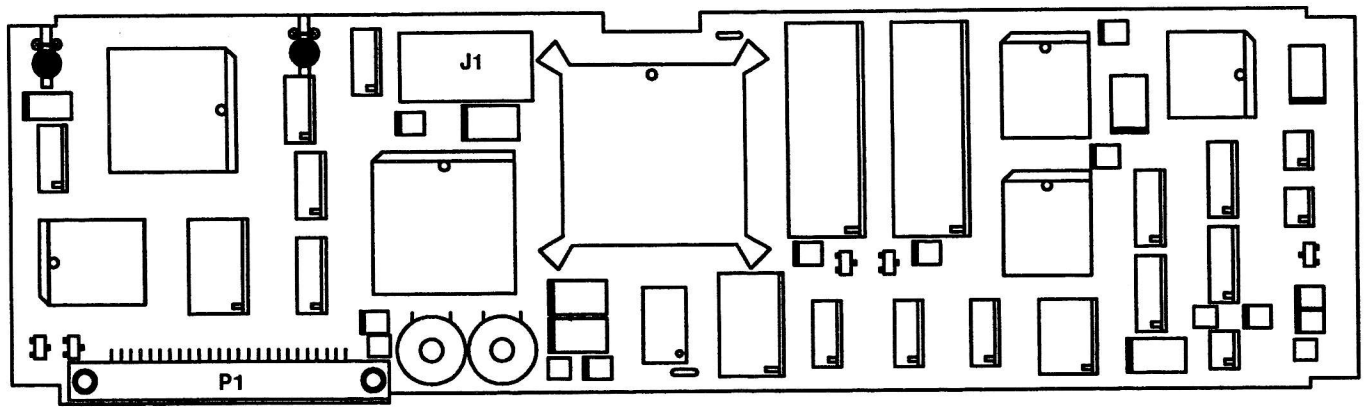

1694-041

**Figure 7-4. A3 LPC Vocoder Assembly Component Location Diagram
(10372-3440 Rev. A)**

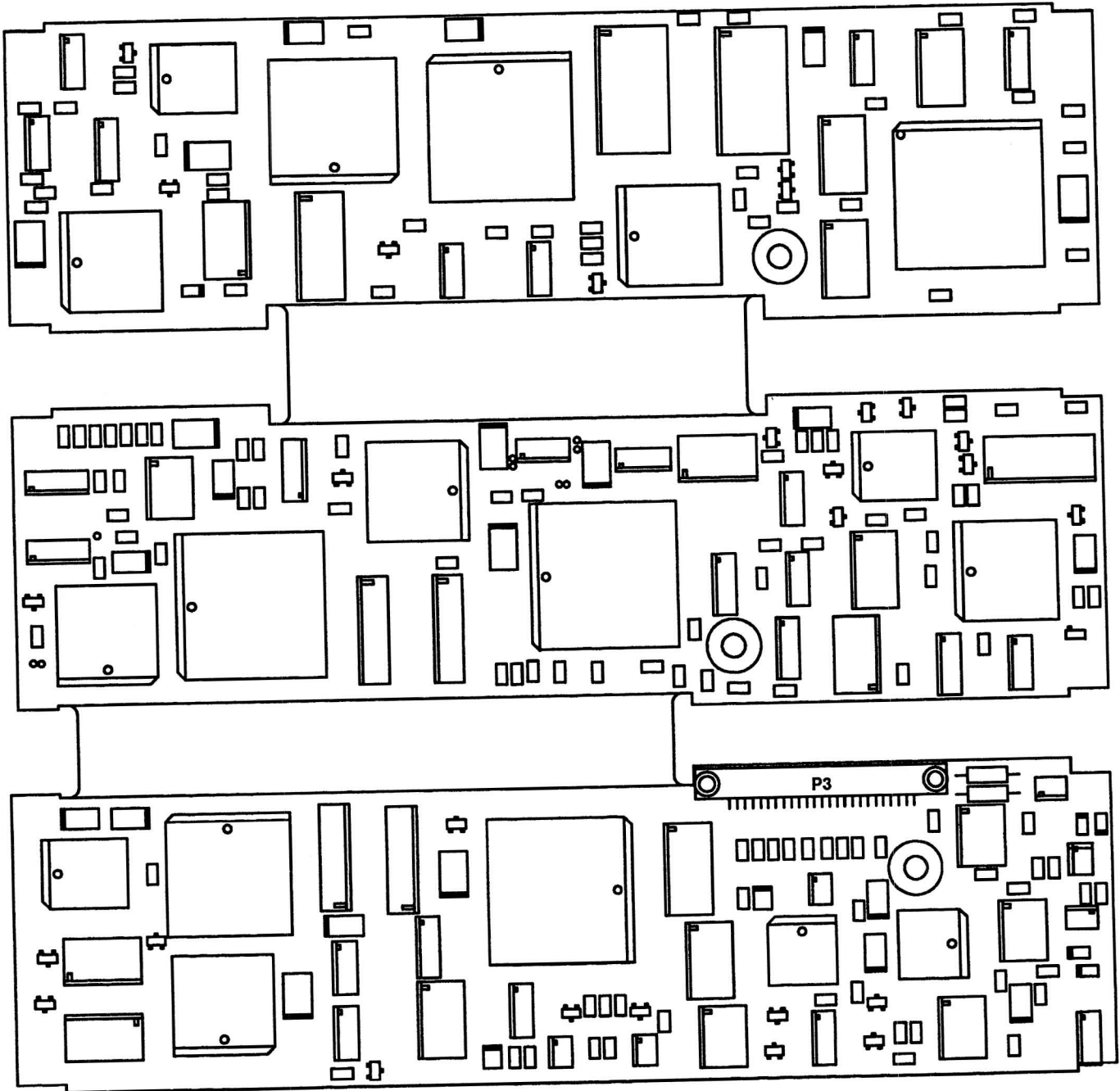

1694-042

**Figure 7-5. A4 Signal Processor PWB Assembly Component Location Diagram
(10303-2500 Rev. C) (RT-1694(P) Configuration)**

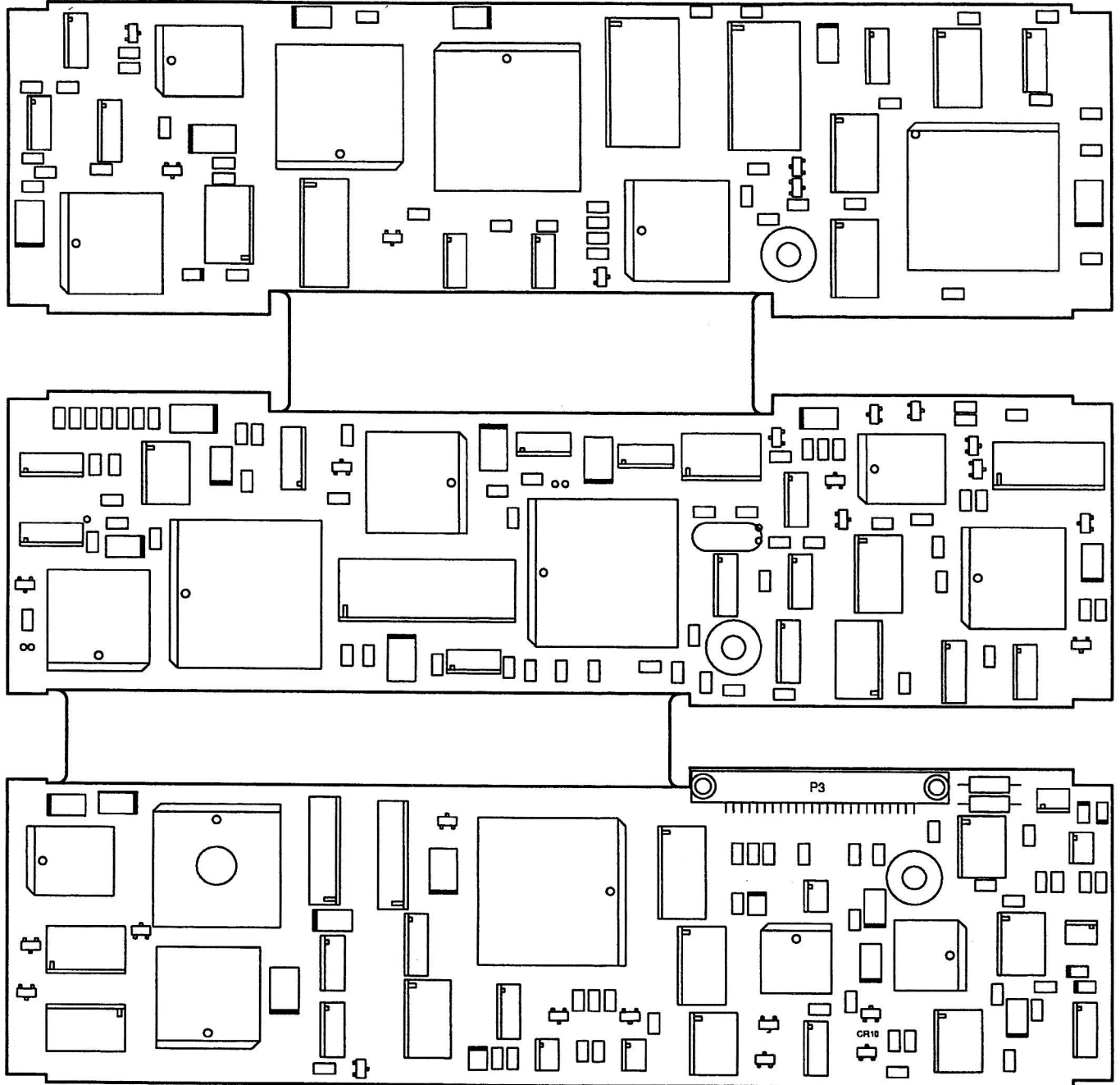

1694_059

**Figure 7-6. A4 Signal Processor PWB Assembly Component Location Diagram
(10530-2500 Rev. -) (RT-1694B(P)/U Configuration)**

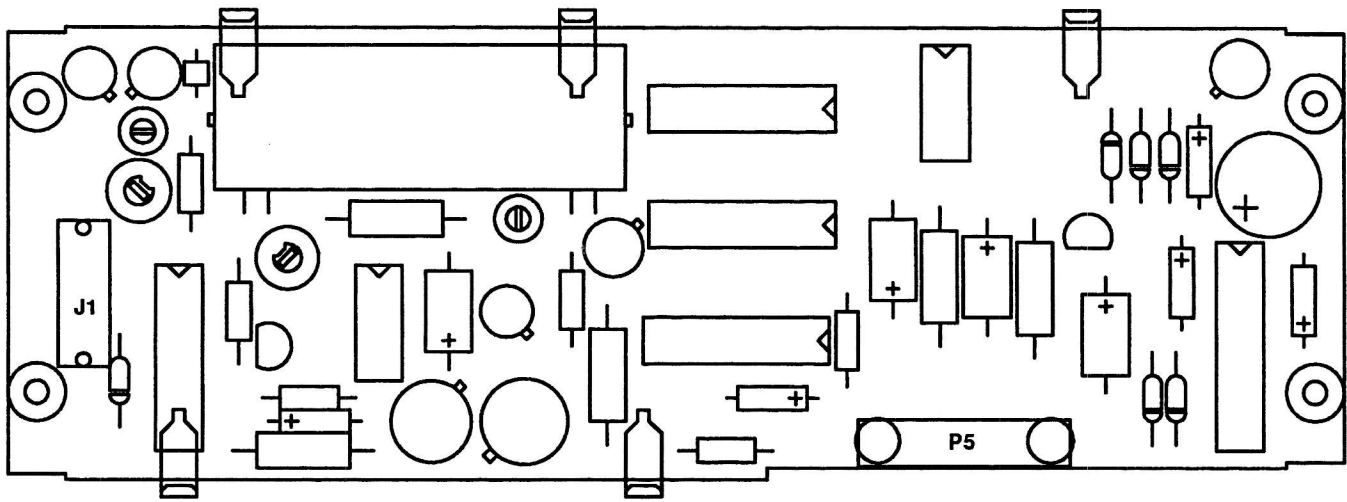

1694-043

**Figure 7-7. A5A1 Second and Third Converter PWB Assembly Component Location Diagram
(10303-2610 Rev. B)**

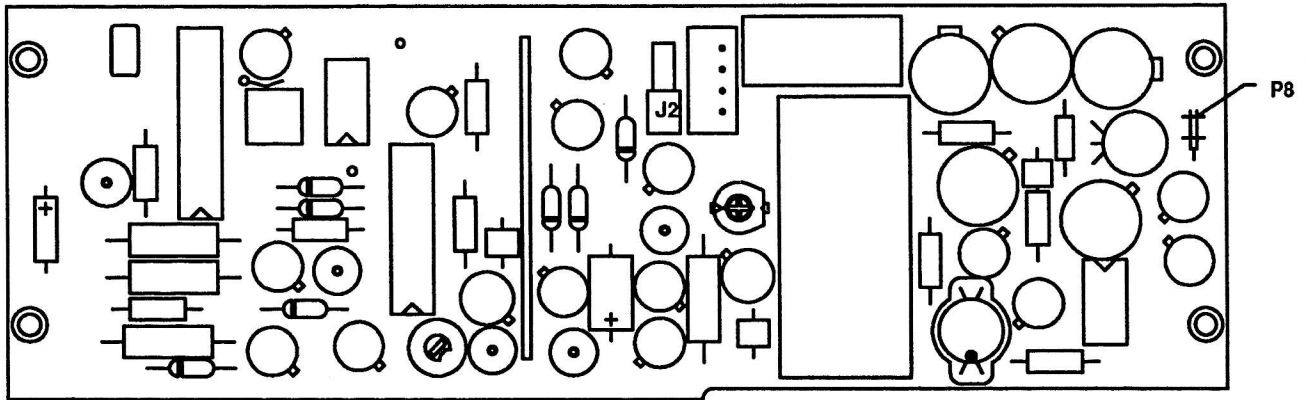

1694-044

**Figure 7-8. A5A2 First Converter PWB Assembly Component Location Diagram
(10303-2270 Rev. E)**

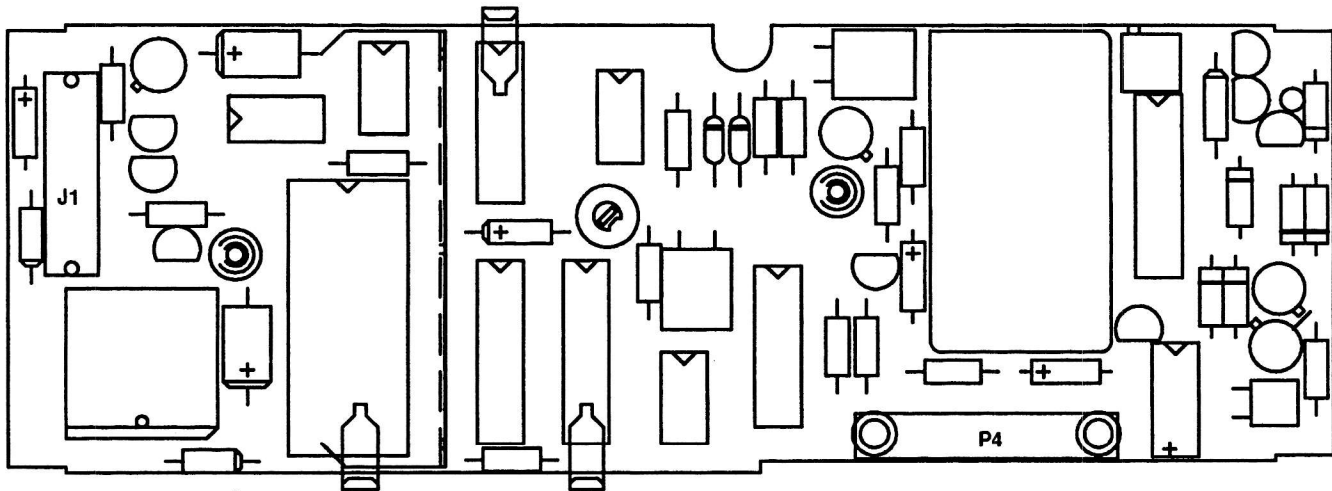

1694-045

**Figure 7-9. A6A1 Reference Generator PWB Assembly Component Location Diagram
(10303-2710 Rev. C)**

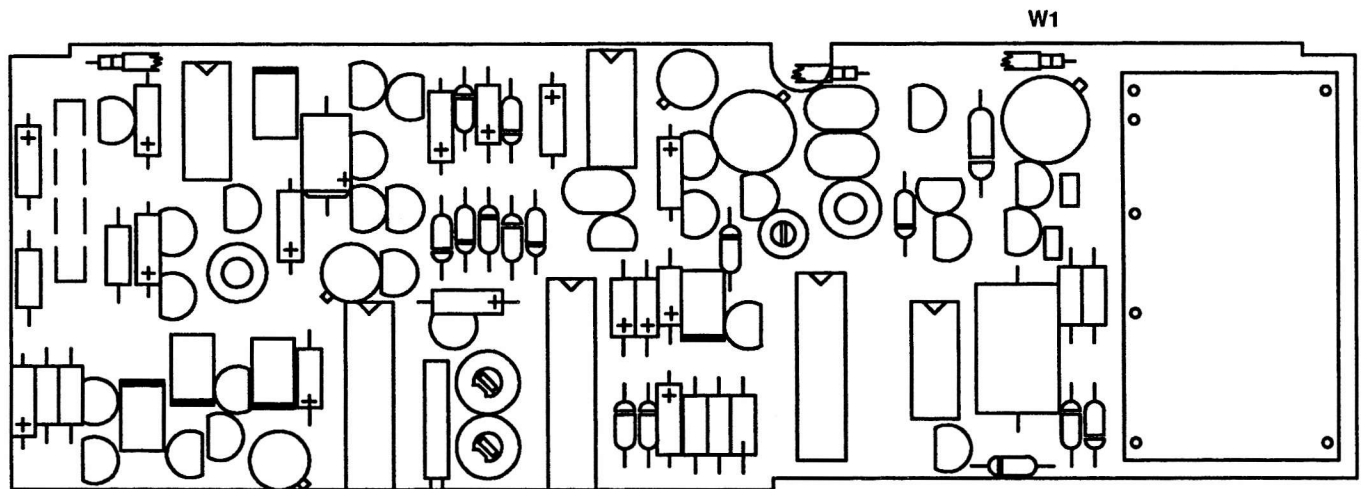

1694-046

**Figure 7-10. A6A2 Synthesizer PWB Assembly Component Location Diagram
(10303-2720 Rev. A)**

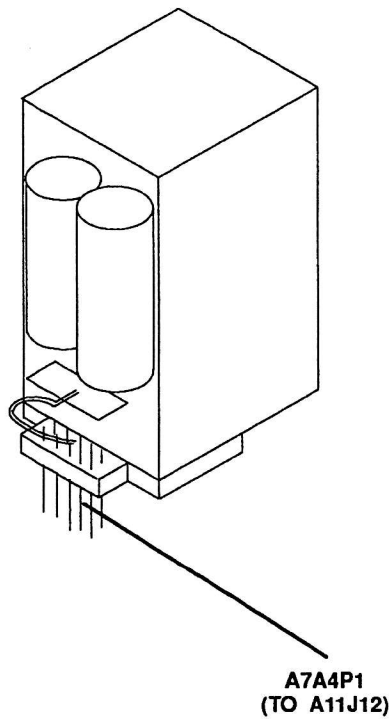

1694-047

**Figure 7-11. A7 Power Supply Assembly Component Location Diagram
(10303-2200)**

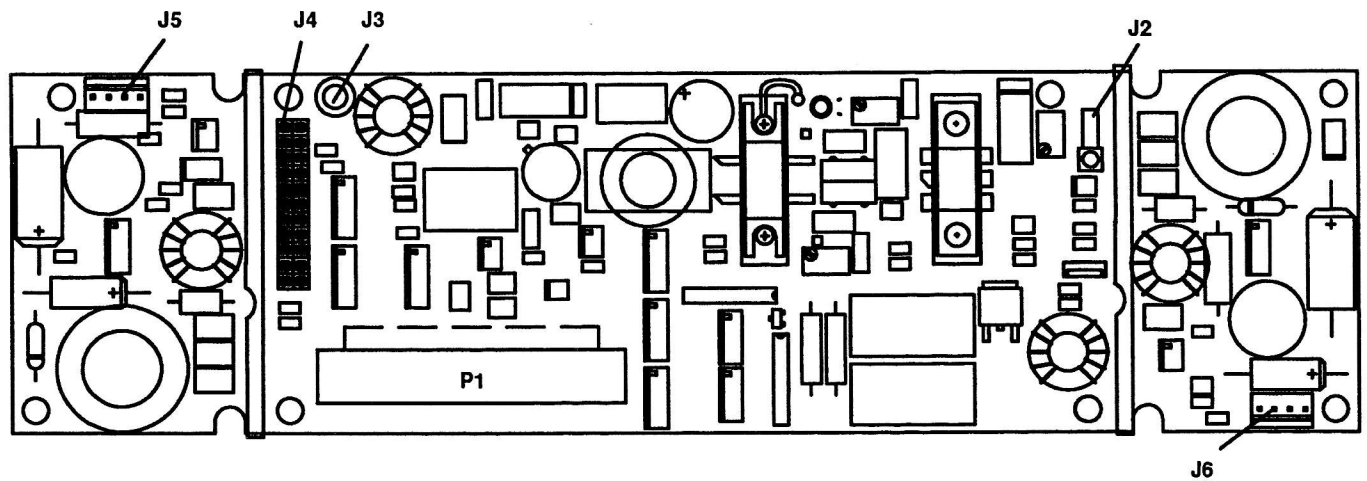

1694-048

**Figure 7-12. A8A1 PA/Battery Charger PWB Assembly Component Location Drawing
(10303-2130 Rev. C) (RT-1694(P) Configuration)**

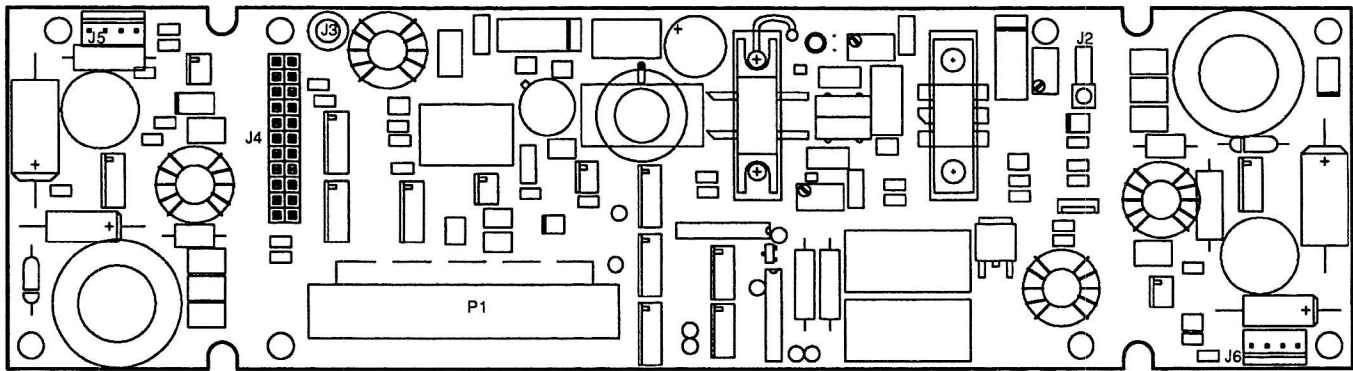

TOP VIEW

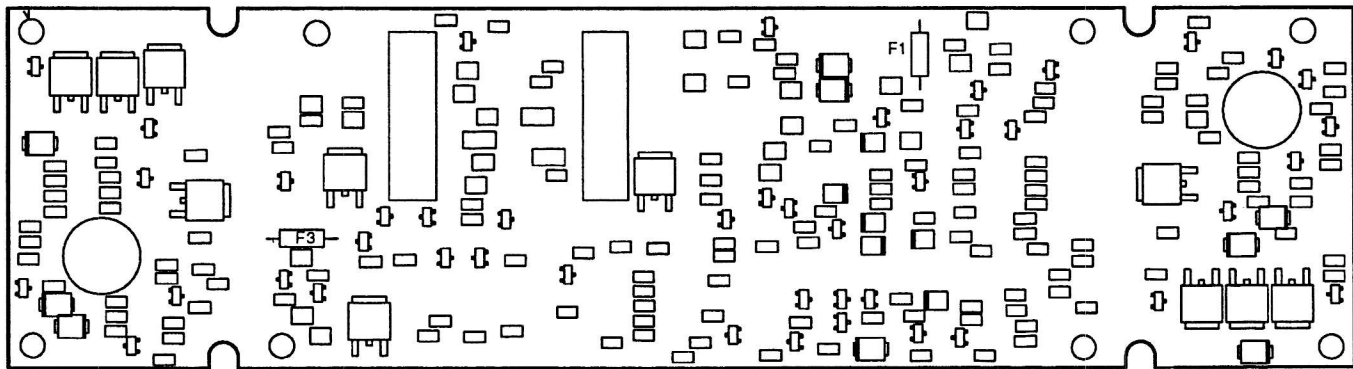

BOTTOM VIEW

1694-060

**Figure 7-13. A8A1 PA/Battery Charger PWB Assembly Component Location Drawing
(10530-2130 Rev. -) (RT-1694B(P)/U Configuration)**

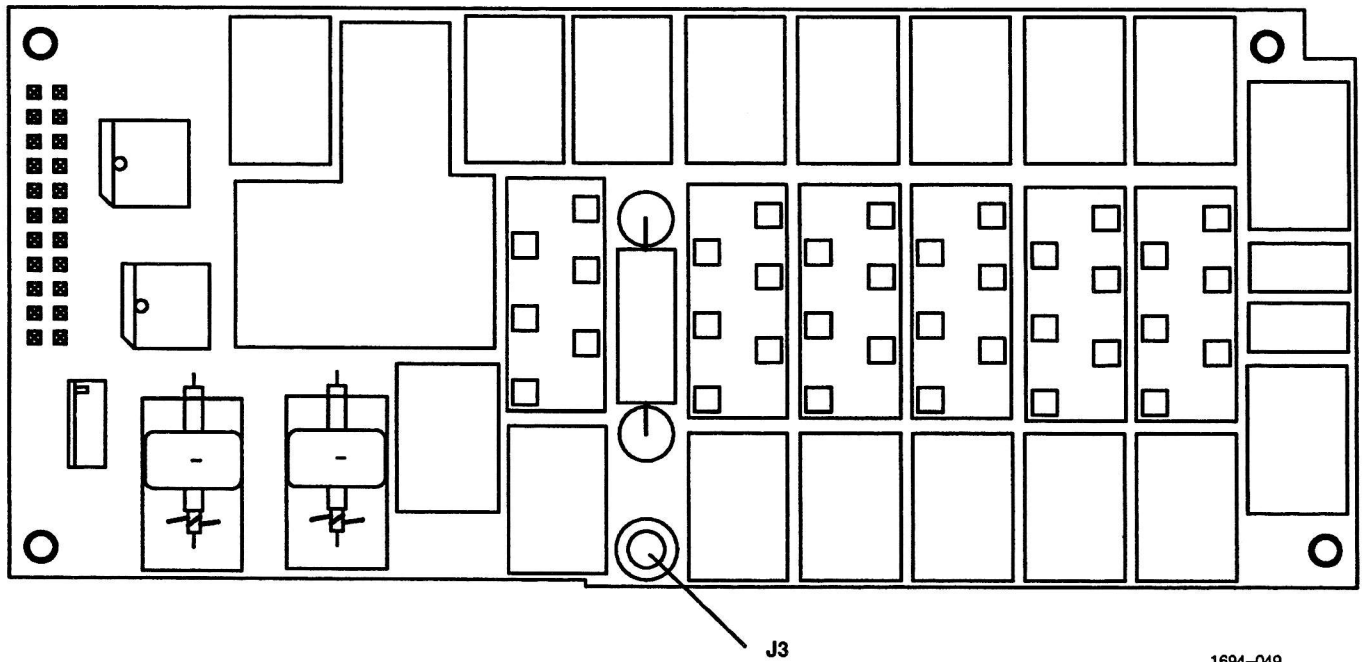

1694-049

**Figure 7-14. A8A2 Harmonic Filter PWB Assembly Component Location Diagram
(10303-2140 Rev. C)**

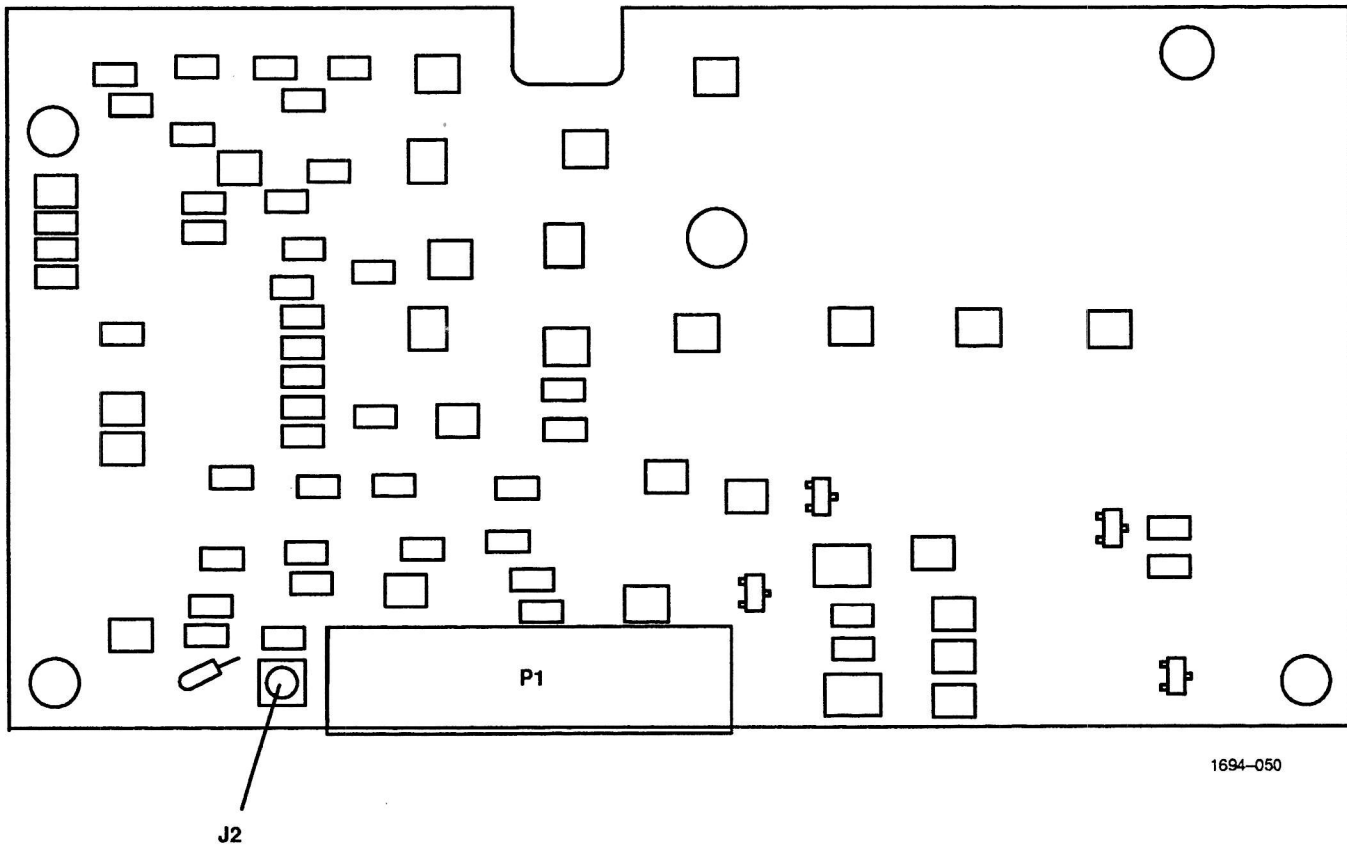

**Figure 7-15. A9A1 Coupler Input PWB Assembly Component Location Diagram
(10303-2150 Rev. D)**

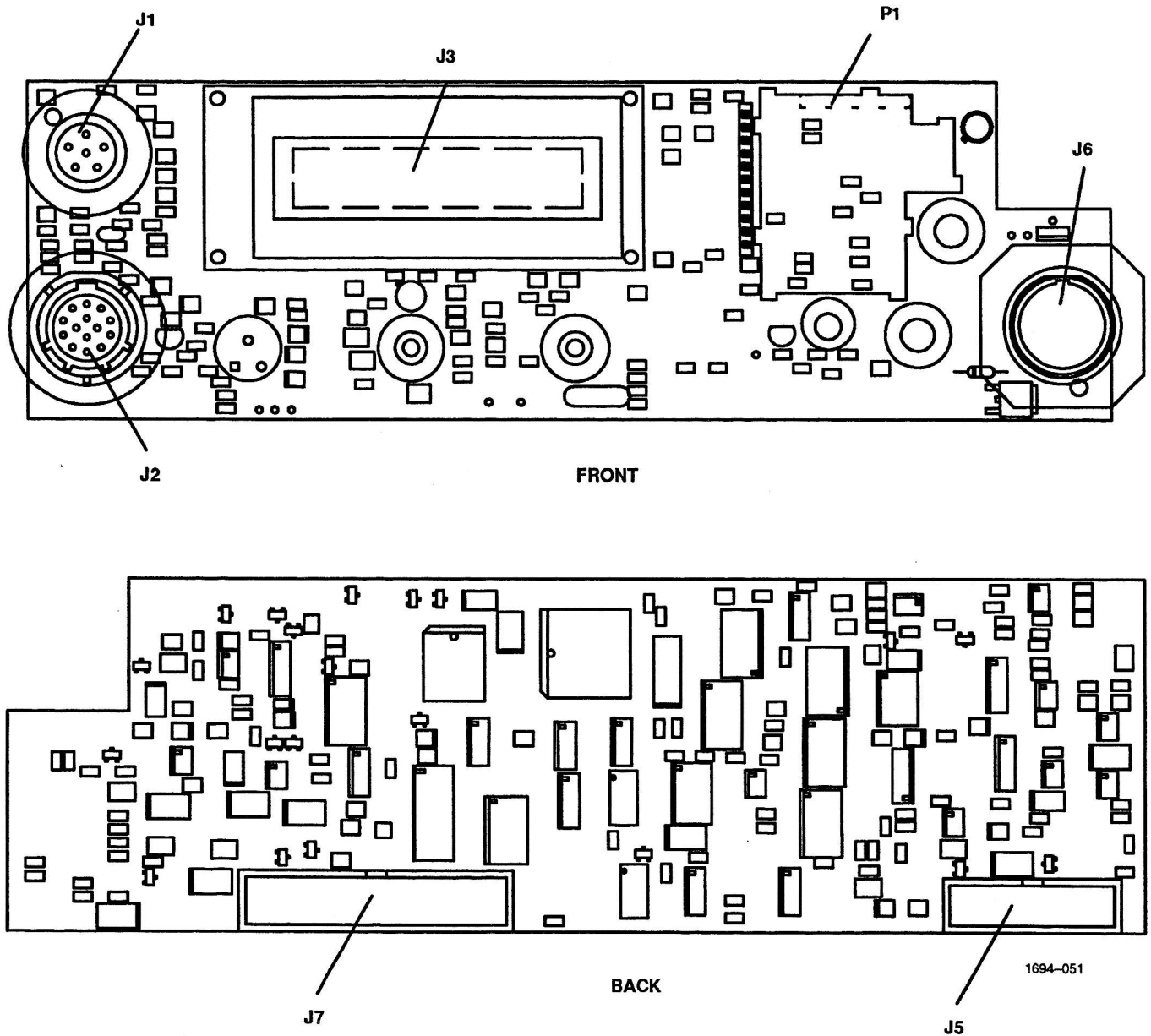
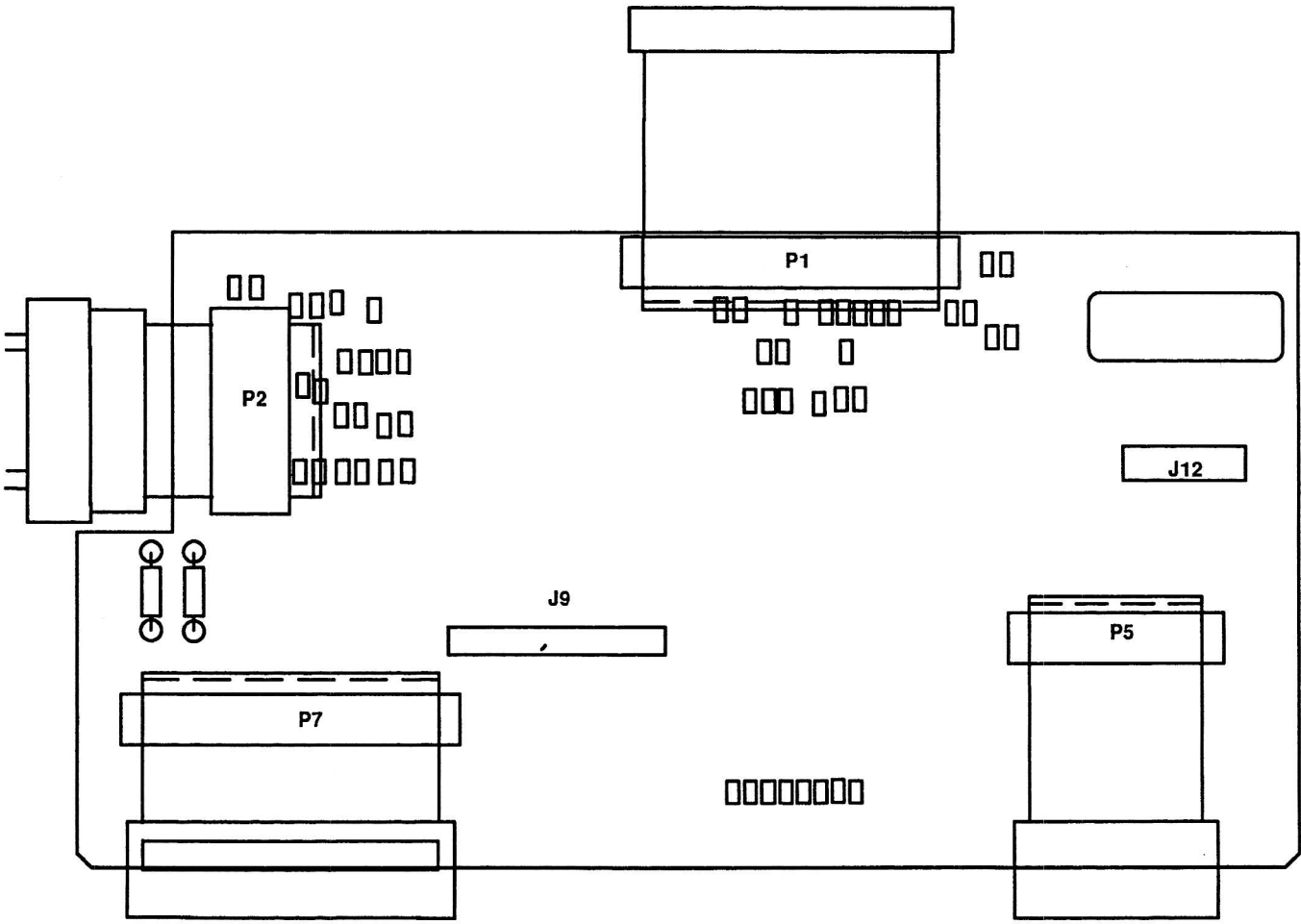
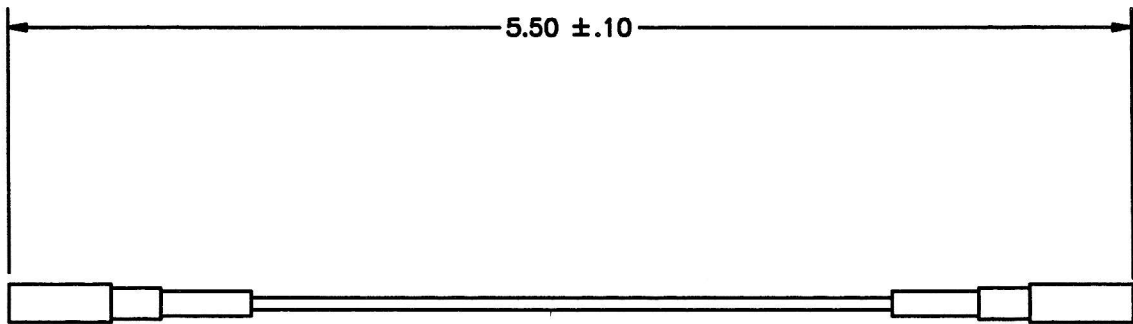

Figure 7-16. A10A1 Audio/Control PWB Assembly Component Location Diagram
(10303-2100 Rev. D)



1694-052

**Figure 7-17. A11 Motherboard Assembly Component Location Diagram
(10303-2170 Rev. E)**



1694-053

**Figure 7-18. W1 RF Cable Assembly (PA-Coupler) Component Location Diagram
(10372-1037 Rev. B)**

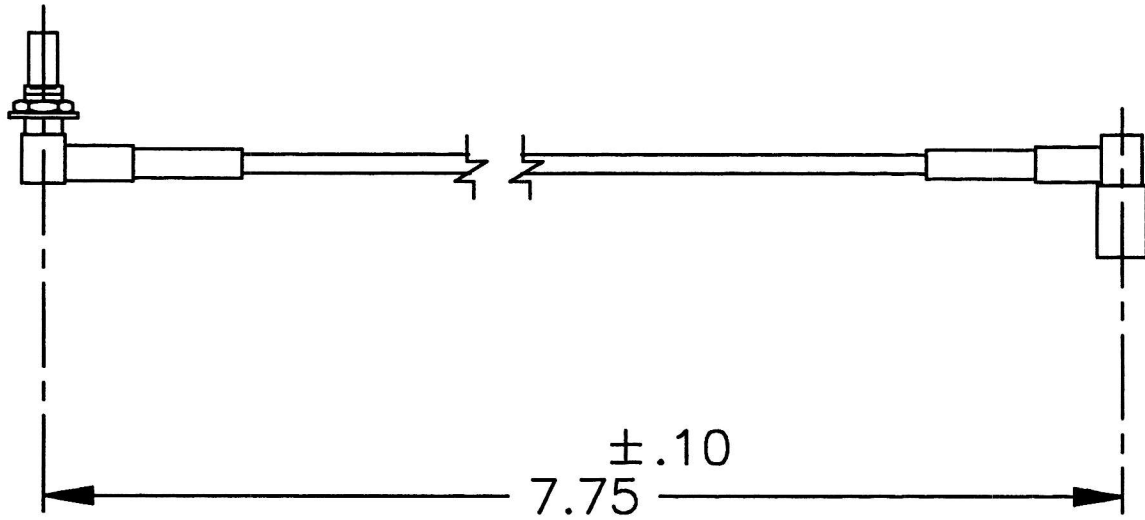

1694-054

**Figure 7-19. W2 RF Cable Assembly (PA-Receiver/Exciter) Component Location Diagram
(10372-1053 Rev. A)**

CHAPTER 8

INSTALLATION

8.1 INTRODUCTION

This chapter describes the following:

- Site information – Paragraph 8.2
- Tools and materials required – Paragraph 8.3
- Unpacking and repacking – Paragraph 8.4
- Site installation – Paragraph 8.5
- Installation checkout – Paragraph 8.6

8.2 SITE INFORMATION

8.2.1 General

The information in the following paragraphs provides general guidelines for setting up the hot test bed radio system. Select a ventilated, well-lighted location. Avoid placing the system in a busy or congested area, or where there is excessive noise. The following are general site considerations:

- Availability of power source, earth ground, antenna, and other items as required
- Ease of operation, maintenance, or removal and replacement
- Ventilation
- Clearance of connection cables to the back of the radio, antenna coupler, and other applicable equipment

8.2.2 General Guidelines

The information contained in the following paragraphs provides general site guidelines. Before choosing a site, become familiar with the dimensions shown in Figure 8-1. Ensure there is plenty of room for maintenance when the unit is installed.

8.2.3 Grounding

Follow these guidelines when grounding the hot test bed radio system.

WARNING

Do not daisy-chain ground connections, as voltage differentials develop over long distances. Any artificial ground system must also be connected to the primary power source ground to prevent generation of Radio Frequency Interference (RFI) and high-voltage electromagnetic fields around the equipment.

The receiver-transmitter ground terminal must be connected to a grounded pipe (such as a cold water pipe), preferably where the pipe enters the ground, or a steel or copper rod driven six to ten feet into the soil. In situations where the water table is far below the surface (such as desert or mountainous terrain), it may be necessary to create an artificial ground system by burying steel or copper plates six to ten inches below the surface, and connecting them together directly below the receiver-transmitter location. In all cases, such grounds must be connected to the receiver-transmitter using at least No. 8 copper cable directly from the ground point.

8.2.4 Dimension and Weight Information

Figure 8-1 and Table 8-1 list the overall dimensions of the receiver-transmitter (with no batteries attached). The RT-1694(P) weighs 8.5 pounds (3.86 kilograms). The RT-1694B(P)/U weighs 7.45 pounds (3.38 kilograms).

Table 8-1. Receiver-Transmitter Dimensions

Parameter	Dimension
Height	3.1 inches (7.8 centimeters)
Width	10.4 inches (26.4 centimeters)
Depth	8.5 inches (21.6 centimeters)

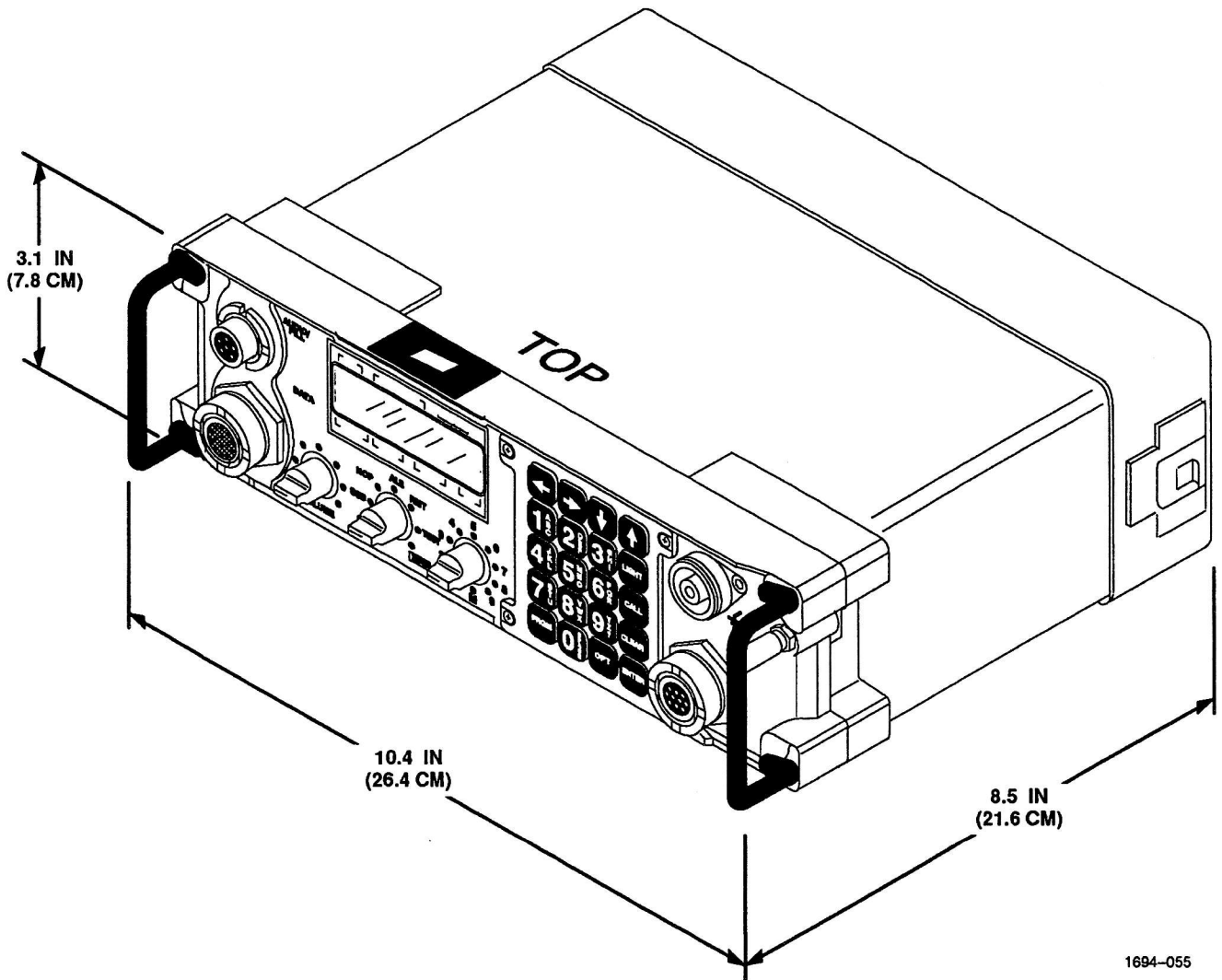

1694-055

Figure 8-1. Receiver-Transmitter Dimensions

8.2.5 Environmental

The receiver-transmitter will perform in the environment specified in Chapter 1, Table 1-1.

8.3 TOOLS AND MATERIALS REQUIRED

Installation of the receiver-transmitter requires no special tools or materials.

8.4 UNPACKING AND REPACKING

Equipment is packed in corrugated boxes. A two-piece foam enclosure protects the equipment against corrosion and rough handling. The boxes and packing materials should be retained in case the equipment is reshipped.

8.4.1 Unpacking

Perform the following procedure to unpack the receiver-transmitter:

- a. Inspect the exterior of the box for signs of damage during shipment. Note any problems and report them to the proper authority. An external sticker on the shipping box provides additional instructions concerning inspection of the package.
- b. Move the boxed equipment to the general location where it is to be installed.
- c. After removing the equipment, check the contents against the packing slip to see that the shipment is complete. Report discrepancies to Harris/RF Communications' Customer Service Department (telephone: 716-244-5830).

8.4.2 Repacking

Perform the following procedure to repack the receiver-transmitter:

- a. Use the original box, if it was retained. If not, use a box that allows three inches of clearance on all sides of the receiver-transmitter.
- b. Use the original packing material, if it was retained. If not, use foam packing material to fill the space between the receiver-transmitter and the box. Surround the entire unit with three inches of foam packing material.
- c. Use a good quality packing tape (or straps) to seal the box after closing.

8.5 SITE INSTALLATION

The following paragraphs describe the power requirements and ancillary items kit required for properly installing the receiver-transmitter. Cabling, jumper and DIP switch settings, unit removal and installation procedures, clearance and ventilation requirements, and mounting information are also included.

8.5.1 Power Requirements

Power requirements are +24 Vdc at 8 A, maximum.

8.5.2 Ancillary Items Kit

The receiver-transmitter is not supplied with an ancillary items kit.

8.5.3 Interconnect Diagrams

Figure 8-2 is the interconnect diagram for hot test bed radio system. Table 8-2 identifies the hot test bed items.

Table 8-2. Hot Test Bed Items

Reference	Item Name	Part Number	Cage Code
1	RT-1694(P) or RT-1694B(P)/U	10372-1000-01 10530-1000-01	14304
2	Power Supply	6291A	28480
3	Cable Assembly, DC Power	10394-9010	14304
4	Handset (H-250/U)	10075-1344-01	14304
5	Cable Assembly, RF, BNC (m)	10503A	28480
6	Adapter, N-type (m) to BNC (f)	M55339/20-00201	81349
7	Attenuator	77B6-30	70998

8.5.4 Jumper/DIP Switch Settings

There are no jumper or DIP switch setting in the receiver-transmitter.

8.5.5 Unit Removal and Installation Procedures

There are no special procedures required for removing or installing the receiver-transmitter into the hot test bed radio system. For information on removing or installing the receiver-transmitter into a base or vehicular system, refer to the RF-5200 FALCON™ Series Tactical Communications Manpack System Manual (10515-0006-4200).

8.5.6 Access Clearance and Ventilation Requirements

When possible, the following clearance and ventilation requirements apply:

- There should be at least 41 inches of clearance in front of the radio system for maintenance personnel.
- There should be at least 1.5 inches clearance above the receiver-transmitter.

When adequate space is provided as described above, special ventilation requirements are not necessary.

8.5.7 Mounting

There are several options for mounting the receiver-transmitter. For mounting information, refer to the RF-5200 FALCON™ Series Tactical Communications Manpack System Manual (10515-0006-4200).

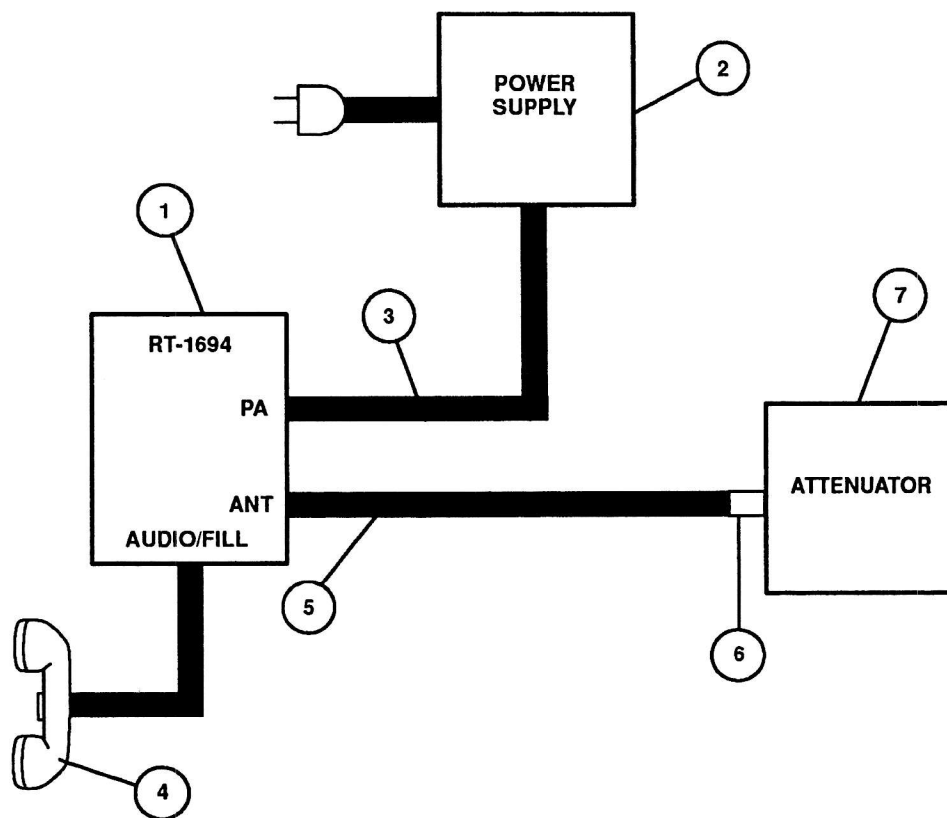

1694-056

Figure 8-2. Typical Hot Test Bed Interconnect Diagram

8.6 INSTALLATION CHECKOUT

Hot test bed installation checkout has three phases. Phase 1 is a pre-energizing check to make sure that the unit is installed correctly and that all support items are nearby. Phase 2 covers the unit's power up and preliminary tests. Phase 3 tests all the functions of the receiver-transmitter.

8.6.1 Phase 1 – Hot Test Bed Installation Inspection and Pre-Power Up Procedures

When the receiver-transmitter is installed in the hot test bed and all connector cables attached, verify that the following items are completed:

- Ensure all connectors are attached and associated hardware is secure.
- Check that system units are connected to ground, preferably at a single point.
- Verify that ground wires are connected between the receiver-transmitter, the Direct Current (DC) power supply, and a known good ground.
- Check securing hardware to be sure the equipment cannot be tipped over or moved.
- Check that area cooling is adequate for removing heat that may develop during equipment operation.
- Verify that the power source is of adequate capability and adequately protected for the radio's load and that installation of the power cable is correct.
- Check any companion equipment, such as the power supply, or remote control, for operational readiness.

8.6.2 Phase 2 – Initial Turn-On and Preliminary Tests

To turn the unit on, refer to Chapter 2, Table 2-2. Special preliminary tests are not necessary.

8.6.3 Phase 3 – Installation Verification Test

To verify receiver-transmitter performance, run Built-in Test (BIT). Refer to Chapter 2, Table 2-2.

CHAPTER 9

ACCESSORIES

9.1 INTRODUCTION

This chapter contains accessory information describing support packages and equipment accessories that are available for the receiver-transmitter. These items add capabilities, provide supplemental instruction in operations and maintenance, recommend spares and tools for product preservation and repair, and list associated documentation to enhance the overall mission effectiveness of the receiver-transmitter.

These items may be ordered directly from Harris/RF Communications using the order number provided with each description.

9.1.1 Support Packages

Support packages are items that are not required to utilize the receiver-transmitter, but furnish the user with a source of instruction and a means of maintaining equipment integrity. Support packages are considered and generated for each maintenance level. For information regarding maintenance levels, refer to Chapter 1, Paragraph 1.2. A summary of support packages and order numbers is provided in Table 9-1. Refer to the following paragraphs:

- Extended Warranties and Service Contracts – Paragraph 9.1.1.1
- Training – Paragraph 9.1.1.2
- Tools – Paragraph 9.1.1.3
- Test Equipment – Paragraph 9.1.1.4
- Maintenance Aids – Paragraph 9.1.1.5
- Manuals – Paragraph 9.1.1.6
- Spares Kits – Paragraph 9.1.1.7
- Hot Test Bed Kits – Paragraph 9.1.1.8

Table 9-1. Receiver-Transmitter Support Packages

Support Package	Maintenance Concept Supported	Order Number
Training Courses	Level I Level II Level III Level II and III (unit only) Level II and III (system)	10515-0006-0100 10515-0006-0200 10515-0006-0300 10515-0006-0500 10515-0006-0600
Tool Kits	Level I Level II Level III Level II and III (unit only) Level II and III (system)	not required 10515-0006-1200 10515-0006-1300 10515-0006-1500 10515-0006-1600
Test Measurement Equipment Kits	Level I Level II Level III Level II and III (unit only) Level II and III (system)	not required 10515-0006-2200 10515-0006-2300 10515-0006-2500 10515-0006-2600
Maintenance Aids	Level I Level II Level III (unit only) Level III (system)	not required not required 10515-0006-3300 10515-0006-3400
Manuals	Level I Level II Level III	10372-0004, -0006 10515-0006-4200 10515-0007-4300
Spares Kits	Level I Level II Level III	not required 10515-0006-5200 10515-0006-5300
Hot Test Bed Kits	Level I Level II Level III (unit only) Level III (system)	not required not required 10515-0006-6300 10515-0006-6400

9.1.1.1 Extended Warranties and Service Contracts

Harris/RF Communications offers extended warranties and service contracts. An extended warranty lengthens the original warranty provided with Harris/RF Communications equipment and systems. Customers who want factory-trained field service personnel to assist in the installation, operation, maintenance, and service of their communications equipment can order a service contract. For more information, call the Harris/RF Communications marketing office (telephone: 716-244-5830).

9.1.1.2 Training

Training provides the user with valuable operation and maintenance knowledge gained through instruction and hands-on experience.

When ordering non-English training, please specify at time of order.

The following is a description of the levels of training:

- **Level I Training** provides thorough understanding of basic operating functions, equipment inspection procedures, and the use of operator cards.
- **Level II Training** furnishes the skills for performing corrective maintenance, localizing faults to a unit, performance of general scheduled maintenance procedures, use of basic test equipment, and use of the System (Level II) Manual.
- **Level III Training** equips maintenance personnel with the skills needed to perform corrective maintenance and to localize faults to modules, assemblies, and chassis-mounted components. The training also equips personnel with skills to conduct necessary alignment and adjustments, to conduct detailed scheduled maintenance, and to use test equipment, maintenance aids, and the Maintenance (Level III) Manual.
- **Radio System Training** includes a complete training package that supports all major radio system units for Levels I, II, and III.

9.1.1.3 Tools

Tool kits for Maintenance Levels II, III, and IV are available to ensure that common items required to install, maintain, and disassemble/reassemble the unit are available to the maintainer. The following is a description of the tool kits:

- **Level I Tools** are not required.
- **Level II Tools** include items needed to install or remove the unit from the radio system and to perform general scheduled maintenance.
- **Level III Tools** include items required to perform corrective and scheduled maintenance down to the module or chassis-mounted component.
- **Level II and III Receiver-Transmitter Tools** include items required to perform Level II and III maintenance on the receiver-transmitter, without duplicating items.
- **Level II and III Radio System Tools** include all items required to perform Level II and III maintenance on all major units of the radio system, without duplicating items.

9.1.1.4 Test Measurement Equipment

Test equipment kits for Maintenance Levels II, III, and IV are available to ensure that measurement items required to perform corrective and scheduled maintenance are available to the maintainer. These are used to take measurements off a unit, system, or hot test bed. The following is a description of the test measurement equipment kits:

- **Level I Test Measurement Equipment** is not required.
- **Level II Test Measurement Equipment** includes measurement items needed to perform corrective maintenance, scheduled maintenance, and fault localization to the unit.
- **Level III Test Measurement Equipment** includes measurement items required to perform corrective and scheduled maintenance down to the module or chassis-mounted component, such as a multimeter, power meter, and oscilloscope.
- **Level II and III Radio System Test Measurement Equipment** includes all measurement items required to perform Level II and III maintenance on all major units of the radio system, without duplicating items.

9.1.1.5 Maintenance Aids

Maintenance aids are special or non-standard tools and test equipment required to perform corrective and scheduled maintenance as specified in the applicable maintenance manual procedures. Special/non-standard tools and test equipment includes items that can only be procured from Harris/RF Communications, such as extender cards, test fixtures, and modified tools. The following is a description of the maintenance aids:

- **Level I Maintenance Aids** are not required.
- **Level II Maintenance Aids** are not required.
- **Level III Maintenance Aids** include items that support corrective and scheduled maintenance tasks associated with Level III maintenance such as extender cards, performance fixtures, pressurization kits, and breakout boxes.

9.1.1.6 Manuals

Manuals are an invaluable, comprehensive resource for the installation, operation, and maintenance of the unit. Manuals also provide a listing of the support equipment recommended to optimize the unit's capabilities and minimize equipment down time.

When ordering non-English manuals, please specify at time of order.

The following is a description of the manuals:

- **Level I Manual** is in the form of operator cards that guide the user in the installation and basic operation of the unit. The cards are an abbreviated form of the information provided in the Level II manual, and are used to facilitate usage in the field.
- **Level II Manual** contains system-level information regarding installation and operation of each significant piece of equipment in the radio system. It also includes procedures for performing corrective maintenance and fault localization to the unit as well as general scheduled maintenance.
- **Level III Manuals** provide information required to perform corrective and scheduled maintenance down to the module or chassis-mounted component.

9.1.1.7 Spares Kits

The maintainer uses spare parts kits to return equipment which has malfunctioned to operational readiness in as short a period of time as possible. The kit may include those items that are consumed during corrective and scheduled maintenance tasks, such as solder, tape, tie wraps, grease, etc.

The following is a description of the spares kits:

- **Level I Spares Kit** is not required.
- **Level II Spares Kit**, other than complete units, contains items that may be externally accessed from the equipment and are usually consumable in nature, such as fuses, filters, or lamps.
- **Level III Spares Kit** includes those items used to repair the unit by replacing a faulty module, Printed Wiring Board (PWB), or chassis-mounted component. Both corrective and scheduled maintenance scenarios are considered. Spares kits contain items sufficient in quantity to provide a basic level of coverage for a minimal number of units, typically five or less. For spares support of more than five units, contact Harris/RF Communications directly.

9.1.1.8 Hot Test Bed Kits

Hot Test Bed Kits are available for Maintenance Level III to ensure that equipment necessary to set up a test bed is available to the maintainer. The test bed is a classification of test equipment from which radio equipment characteristics can be measured. Hot Test Bed Kits consist of power supplies, signal generators, radio receiver-transmitters, and cables.

- **Level I Hot Test Bed Kit** is not required.
- **Level II Hot Test Bed Kit** is not required.
- **Level III Hot Test Bed Kit for the receiver-transmitter** includes system setup items necessary to test the receiver-transmitter at Level III maintenance.
- **Level III Hot Test Bed Kit for the radio system** includes system setup items necessary to test the radio system at Level III maintenance, without duplicating items.

9.1.2 Equipment Accessories

Equipment accessories are items that are not provided with the receiver-transmitter, but can be procured to increase the application and capabilities of the unit. Table 9-2 lists the accessories available for the receiver-transmitter.

Table 9-2. Receiver-Transmitter Accessories

Item Name	Description	Part Number
Rechargeable Nickel-Cadmium (Ni-Cd) Battery	The BB590/U consists of a pair of rechargeable Ni-Cd batteries for the AN/PRC-138 Manpack battery case. The average life of the battery in a high usage/medium power environment is four – six hours.	BB-590/U
Lightweight Lithium Battery	The BA-5590/U is a lightweight, long-life battery for the AN/PRC-138 Manpack Radio Set. A 10372-0300 Battery Case is used to hold one or two BA-5590/U batteries. <i>The BA-5590/U cannot be recharged.</i>	BA-5590/U
Rechargeable Lead-Acid Battery	The BB-490/U consists of a pair of rechargeable lead-acid batteries for the AN/PRC-138 Manpack battery case. The average life of this battery in a high usage/medium power environment is six – eight hours.	BB-490/U
Lightweight Battery Case	The 10530-1300 is a ULTEM 2100™ hi-grade, hi-impact plastic battery case with a 25% reduction in weight from the standard aluminum battery case. It holds two standard Ni-Cd or Lithium battery units.	10530-1300
Battery Case	The 10372-0300 is a standard aluminum battery case which snaps onto the receiver-transmitter back panel and holds two BB-590/U Ni-Cd, two BB-490/U lead-acid, or two BA-5590/U Lithium Battery units. An extra case would allow the user to easily detach a spent battery and case and install new batteries and a case onto the back panel of the receiver-transmitter.	10372-0300
Battery Charger – Trickle	The 10309-0550 provides simultaneous trickle charging of up to six BB-590/U Ni-Cd batteries. Charging time of a fully discharged battery is 14 hours. This battery charger operates on 115 to 230 Vac at 50/60 MHz. Specify voltage when ordering. This charger is not suitable for lead-acid batteries.	10309-0550

Table 9-2. Receiver-Transmitter Accessories – Continued

Item Name	Description	Part Number
Fast Charger	The 10372-0304 is a fast charger for up to four Ni-Cd batteries. This microprocessor-controlled unit incorporates fast-charge, balancing charge, maintenance charge, and recovery charge programs to properly charge and maintain the BB-590/U and other Ni-Cad battery types. It operates on 100 to 265 Vac at 50 to 60 Hz. The typical charge time for one fully discharged BB-590/U is approximately 30 minutes.	10372-0304
Solar Charger	This solar panel operates at 24 Vdc to charge one Ni-Cd battery. Charge time depends on weather conditions. Cables are included.	10372-0950-01
OE-505A/PRC Manpack Whip Antenna Kit	The OE-505A/PRC is the standard antenna kit for the AN/PRC-138(V)2 Manpack System. The kit includes an AT-271A/PRC-25 10-foot (3.1 m) Collapsible Whip Antenna (10012-0241), a 10530-1215-01 Base and Adapter Assembly, a 10530-1250-01 Whip Adapter Assembly, and a 10372-0249-01 Antenna Bag. One OE-505A/PRC Whip Antenna Kit is supplied with each AN/PRC-138 Transceiver.	10530-0240-01
Very High Frequency (VHF) Log-Periodic Transportable Antenna	The RF-289A is a tactical, portable log-periodic antenna system for operation in the 30 to 90 MHz range with a gain of 4 dBi in 30 to 35 MHz, 4.5 dBi in 35 to 76 MHz, and 6 dBi forward gain over average soil. The RF-289A can be configured for vertical or horizontal polarization and can be manually rotated. The package includes a 20-foot (6.1 m) mast, 35 feet (11 m) of RG-58A/U Coax Cable, ground stakes, a mounting base, guy ropes, and a hammer.	RF-289A
VHF Omnidirectional, Transportable Antenna	The RF-290 is a tactical, portable, omnidirectional VHF 30 MHz to 90 MHz antenna. It is easily erected and designed for broadband operations. The system comes complete with a 33-foot (10 m) mast, an 80-foot coax cable with connectors, ground stakes, a base plate, a guy assembly, and a hammer.	RF-290

Table 9-2. Receiver-Transmitter Accessories – Continued

Item Name	Description	Part Number
Antenna – Portable Near Vertical Incidence Skywave (NVIS)	The RF-1936P is a NVIS antenna system. It is rapidly deployable for short- to medium-range communications. The RF-1936P covers the High Frequency (HF) and lo-VHF spectrums. It can be erected in five minutes by two people. The system requires use of an antenna coupler. The package includes a mast assembly and sections, a base plate, a hammer, and ground stakes.	RF-1936P
Antenna – Portable Dipole	The RF-1940 is a lightweight, portable dipole antenna operating in the 3 MHz to 30 MHz range. Its maximum input power is 500 watts. The unit is self-contained, using flat spools lengthened according to the frequency used. An additional throw line attaches to trees and masts. The Radio Frequency (RF) connector is BNC for direct connection to a Manpack.	RF-1940
Vehicular Whip Antenna	The SB-V16B is a vehicular, 16-foot (4.9 m), fiberglass whip antenna which covers the full operating range of the AN-PRC/138 Manpack with a maximum power output of up to 400 watts. This antenna is self-supporting with a feed-through base and mounting hardware.	SB-V16B
Vehicular Metallic “V” Antenna	The SB-V216B is a vehicular antenna configured to enhance short-range HF communications by improving NVIS propagation performance. The antenna is an adjustable “V” configuration consisting of two metallic radiators: one 16 feet (4.9 m) in length and the other 9 feet (2.7 m). The angle of each radiator is mechanically adjustable to provide optimum NVIS performance. The SB-V216B may be configured as a single radiation element for longer range communications. This antenna will mount directly to the RF-292 Universal Antenna Mount.	SB-V216B
Manpack Radio Carrying Bag	The 10372-0460-01 is a radio carrying bag with an adjustable shoulder strap for forward or side sling access. The bag attaches to the Backpack Harness 10372-0450-01 for backpack configuration.	10372-0460-01
Backpack Harness for AN/PRC-138 Manpack	The 10372-0450-01 consists of a rugged, lightweight ruck pack harness and frame. It holds the AN/PRC-138 Manpack in a dorsal access configuration. The 10372-0460-01 Radio Carrying Bag fits inside a ruck pack to the harness. It contains pouches for carrying accessories.	10372-0450-01

Table 9-2. Receiver-Transmitter Accessories – Continued

Item Name	Description	Part Number
Manpack Radio Backpack	The 10530-0460-01 is designed for use by U.S. Army Rangers and consists of a rugged, lightweight backpack design to fit a variety of different manpack radios. The backpack has side pockets for an antenna kit and back pouch for extra batteries. The backpack contains internal flaps for kevlar inserts. The 10530-0460-01 provides the ability to store and carry all items that make up the manpack radio system, plus two extra batteries.	10530-0460-01
H-250/U Lightweight Handset	The 10075-1344-01 is a high-grade, lightweight MIL handset for use with the receiver-transmitter. One handset is supplied with each FALCON™ Series Transceiver System. It is recommended for use with the Linear Predictive Coding (LPC) Digitized Voice Option.	10075-1344-01
Headset with Boom Microphone – Dynamic Mic Element – Single Earpiece	The RF-3014-01 is a high-grade MIL headset with an adjustable boom microphone and a single earpiece for use with the receiver-transmitter.	RF-3014-01
Headset with Boom Microphone – Dynamic Mic Element – Dual Earpiece	The RF-3014-02 is a high-grade MIL headset with an adjustable boom microphone and a dual earpiece for use with the receiver-transmitter.	RF-3014-02
Continuous Wave (CW) Key with Knee Clip	The RF-5016-01 is a MIL-grade telegraph key mounted on a clip that may be fitted over an operator's knee. It is useful for vehicular CW operation, and is used with the receiver-transmitter.	RF-5016-01
CW Base-Station Key	The RF-3016-04 is a MIL-grade telegraph key for use with the receiver-transmitter in base station applications. The unit includes key, cable, and plug.	RF-3016-04
Palm Microphone	The noise-canceling microphone in this palm-held unit includes a built-in, Push-to-Talk (PTT) switch and a coiled cable that terminates in a standard (U-229/U) five-contact connector. The RF-294-07 is intended for use with the receiver-transmitter.	RF-294-07
Headset – Dual Earpiece	The RF-294-08 is a high-grade, MIL, two-earpiece headset unit with a flexible headband, a coiled cable with a clip to attach to the user's clothing, and a standard (U-229/U) five-contact connector. The RF-294-08 is intended for use with the receiver-transmitter.	RF-294-08

Table 9-2. Receiver-Transmitter Accessories – Continued

Item Name	Description	Part Number
24 Vdc Filter/Adapter Unit	The 10372-0850-01 is a vehicular accessory that allows a receiver-transmitter to receive power from a vehicle's 24 Vdc power system. The Filter/Adapter Unit provides Electromagnetic Interference (EMI) filtering, as well as spike, surge, overvoltage, and overcurrent protection. The Filter/Adapter Unit, along with a receiver-transmitter, can be mounted on a 10372-0800-01 Universal Vehicular Shock Mount.	10372-0850-01
Universal Vehicular Shock Mount	The 10372-0800-01 can be used to mount a receiver-transmitter and a 10372-0850-01 24 Vdc Filter/Adapter Unit into a vehicular installation. The 10372-0800-01 can also be adapted to mount the receiver-transmitter connected to its battery case.	10372-0800-01
Vehicular Short Shock Mount	The 10372-0880 can be used to mount a receiver-transmitter, without its battery case removed, into a vehicular installation. When installed in the short shock mount, the receiver-transmitter receives 24 Vdc power from an external power amplifier via the front panel power amplifier connector.	10372-0880

TECHNICAL PUBLICATION EVALUATION FORM

To the User of This Instruction Manual:

HARRIS Corporation, RF Communications Division continually evaluates its technical publications for completeness, technical accuracy, and organization. You can assist in this process by completing and returning this form. Please specify section, page number, figure or table number where applicable.

MANUAL TITLE: _____

MANUAL NUMBER: _____ REVISION: _____ COVER DATE: _____

GENERAL	<u>EXCELLENT</u>	<u>GOOD</u>	<u>FAIR</u>	<u>POOR</u>
TEXT	[]	[]	[]	[]
SETUP/ALIGNMENT INST.	[]	[]	[]	[]
TROUBLESHOOTING INST.	[]	[]	[]	[]
TABLES	[]	[]	[]	[]
ILLUSTRATIONS	[]	[]	[]	[]
PARTS LISTS	[]	[]	[]	[]
SCHEMATIC DIAGRAMS	[]	[]	[]	[]

GENERAL COMMENTS: Please include your suggestions for improvements to the manual. Specify section, page, paragraph, figure number, or table number as applicable. Attach examples or extra pages if more space is needed.

**INTRODUCTION SECTION:
COMMENT**

**INSTALLATION SECTION:
COMMENT**

**OPERATION SECTION:
COMMENT**

**THEORY OF OPERATION SECTION (Technical Descriptions):
COMMENT**

**MAINTENANCE SECTION:
COMMENT**

**SUB-ASSEMBLY SECTIONS:
COMMENT**

TEAR HERE

R.F.P-671D

NAME: _____ DATE: _____

COMPANY: _____

ADDRESS: _____

CITY: _____ STATE: _____

ZIP: _____ COUNTRY: _____

PHONE NUMBER (INCLUDE AREA CODE): _____

NOTE

U.S. POSTAL REGULATIONS NO LONGER PERMIT THE USE OF STAPLES. PLEASE SEAL THIS FORM WITH TAPE.

MAKE FIRST FOLD HERE



MAKE LAST FOLD HERE

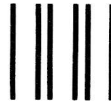
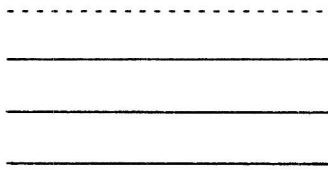

NO POSTAGE
NECESSARY
IF MAILED
IN THE
UNITED STATES

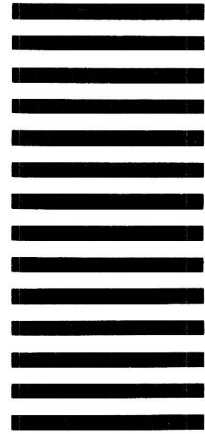

BUSINESS REPLY MAIL
FIRST CLASS PERMIT NO. 4033 ROCHESTER, N.Y.

POSTAGE WILL BE PAID BY ADDRESSEE

HARRIS CORPORATION
RF Communications Division
1680 University Avenue
Rochester, New York 14610 U.S.A.

ATTN: Publications Department

TAPE HERE

TEAR HERE

RF-P-671D