



Rockwell
International

Collins instruction book

Collins Government Telecommunications Group

**Collins 51S-1/1A/1F/1AF/1B
Receiver**



**Rockwell
International**

Collins instruction book

**Collins 51S-1/1A/1F/1AF/1B
Receiver**

**Collins Government
Telecommunications Group
Rockwell International
Cedar Rapids, Iowa 52406**

List of Effective Pages

*The asterisk indicates pages changed, added, or deleted by the current change.

Page No	Issue
Cover	15 Sep 75
Title	15 Sep 75
A thru B	15 Sep 75
C Blank	15 Sep 75
i thru iii	15 Sep 75
iv Blank	15 Sep 75
v	15 Sep 75
1-0 thru 1-10	15 Sep 75
2-1 thru 2-3	15 Sep 75
2-4 Blank	15 Sep 75
3-1 thru 3-5	15 Sep 75
3-6 Blank	15 Sep 75
3-7	15 Sep 75
3-8 Blank	15 Sep 75
4-1 thru 4-14	15 Sep 75
5-1 thru 5-7	15 Sep 75
5-8 Blank	15 Sep 75
6-1 thru 6-43	15 Sep 75
6-44 Blank	15 Sep 75
6-45 thru 6-76	15 Sep 75
7-1 thru 7-3	15 Sep 75
7-4 Blank	15 Sep 75
7-5	15 Sep 75
7-6 Blank	15 Sep 75
7-7	15 Sep 75
7-8 Blank	15 Sep 75
7-9	15 Sep 75
7-10 Blank	15 Sep 75
7-11 thru 7-13	15 Sep 75
7-14 Blank	15 Sep 75
7-15	15 Sep 75
7-16 Blank	15 Sep 75
7-17	15 Sep 75
7-18 Blank	15 Sep 75
7-19	15 Sep 75
7-20 Blank	15 Sep 75
7-21	15 Sep 75
7-22 Blank	15 Sep 75
7-23	15 Sep 75
7-24 Blank	15 Sep 75
7-25 thru 7-26	15 Sep 75

Collins welcomes your comments concerning this instruction book. Although every effort has been made to keep it free of errors, some do occur. When reporting a specific problem, please describe it briefly and include the instruction book part number, the paragraph or figure number, and the page number.

Send your comments to: Publications Department
Collins Government
Telecommunications Group
Rockwell International
Cedar Rapids, Iowa 52406

table of contents

	<i>Page</i>
Section 1 Installation	1-1
1.1 Unpacking.....	1-1
1.2 Mounting and Cabling for 51S-1/1A/1F/1AF.....	1-1
1.2.1 Power Cable.....	1-1
1.2.2 Audio Outputs.....	1-1
1.2.3 Antenna.....	1-1
1.3 Mounting and Cabling for 51S-1B.....	1-1
1.4 Supplementary Installation Data for 51S-1/1A/1F/1AF.....	1-3
1.4.1 IF. Output.....	1-3
1.4.2 External RF Gain.....	1-3
1.4.3 Mute.....	1-3
1.4.4 Sidetone.....	1-3
1.4.5 Line Output.....	1-3
1.4.6 External VFO Connection.....	1-3
1.4.7 Rejection Tuning.....	1-4
1.5 Supplementary Installation Data for 51S-1B.....	1-4
1.5.1 IF. Output.....	1-4
1.5.2 External RF Gain Control Line.....	1-4
1.5.3 Mute.....	1-4
1.5.4 Sidetone.....	1-4
1.5.5 Line Output.....	1-4
1.5.6 External VFO Connection.....	1-4
1.5.7 Rejection Tuning.....	1-4
Section 2 Operation	2-1
2.1 General.....	2-1
2.2 Frequency Reading.....	2-1
2.3 Single-Sideband Reception.....	2-1
2.4 CW Reception.....	2-2
2.5 AM Reception.....	2-2
2.6 Calibration.....	2-3
2.7 Dial Brake	2-3
Section 3 Principles of Operation	3-1
3.1 General.....	3-1
3.2 Circuit Descriptions.....	3-1
3.2.1 RF Amplifier.....	3-1
3.2.2 First Mixer.....	3-1

table of contents (cont)

	<i>Page</i>
3.2.3 Second Mixer.....	3-2
3.2.4 Third Mixer.....	3-2
3.2.5 First IF. Amplifier.....	3-3
3.2.6 Q-Multiplier.....	3-3
3.2.7 Second IF. Amplifier.....	3-3
3.2.8 Third IF. Amplifier.....	3-3
3.2.9 Product Demodulator.....	3-3
3.2.10 SSB/CW Preamplifier.....	3-3
3.2.11 Audio Amplifiers.....	3-3
3.2.12 Low-Frequency Mixer.....	3-4
3.2.13 Oscillators.....	3-4
3.2.14 Special Circuits.....	3-4
Section 4 Service Instructions.....	4-1
4.1 Preparation for Servicing.....	4-1
4.1.1 General.....	4-1
4.1.2 Chassis Removal From Cabinet.....	4-1
4.1.3 Chassis Removal From Rack Mount.....	4-2
4.2 Receiver Signal Tracing.....	4-2
4.3 Voltage and Resistance Measurements.....	4-2
4.3.1 Vacuum Tube Measurements.....	4-2
4.3.2 Transistor Measurements.....	4-4
4.4 Alignment.....	4-4
4.4.1 100-kHz Calibrator Adjustment.....	4-4
4.4.2 RF Meter Zeroing.....	4-5
4.4.3 IF. Alignment.....	4-6
4.4.4 3- to 2-MHz Variable IF. Alignment.....	4-7
4.4.5 14.5- to 15.5-MHz Band Pass Alignment.....	4-7
4.4.6 RF Alignment.....	4-7
4.4.7 Megahertz Oscillator Alignment.....	4-8
4.4.8 17.5-MHz Oscillator Alignment.....	4-9
4.4.9 LF Oscillator Alignment.....	4-9
4.4.10 Megahertz Injection Frequency Adjustment.....	4-9
4.4.11 Receiver Gain Adjustment.....	4-10
4.4.12 RF Meter Calibration.....	4-10
4.4.13 Q-Multiplier Alignment.....	4-10
4.4.14 VFO Alignment.....	4-11
4.5 Megacycles Drive Chain Replacement.....	4-11
4.6 Turret Wafer Replacement.....	4-13
4.7 Lamp Replacement	4-14

table of contents (cont)

	<i>Page</i>
Section 5 Specifications	5-1
5.1 51S-1/1A/1F/1AF/1B Receiver	5-1
5.2 Requirements for Operation.....	5-1
5.3 Specifications.....	5-2
5.4 Tube and Semiconductor Complement.....	5-5
5.5 Available Accessories.....	5-6
5.6 Difference Data	5-6
5.7 Schematic Change Information	5-6
Section 6 Parts List.....	6-1
6.1 Introduction.....	6-1
6.2 Group Assembly Parts List	6-7
6.3 Numerical Index	6-59
6.4 Reference Designation Index	6-69
Section 7 Illustrations.....	7-1

list of illustrations

<i>Figure</i>	<i>Page</i>
1-1 External Connections to 51S-1/1A/1F/1AF	1-0
1-2 600-Ohm Line and Remote RF Gain Control Options for 51S-1/1A/1F/1AF	1-2
1-3 51S-1/1A Receiver, Outline and Mounting Dimensions	1-5
1-4 51S-1/1A Receiver, Outline and Mounting Dimensions with 351E-4 Mount (C712-24-5)	1-6
1-5 51S-1F/1AF Rack Mount and 51S-1/1A Hinged Mount, Outline and Mounting Dimensions	1-7
1-6 51S-1B Receiver, Outline and Mounting Dimensions with 350D-5 Base Shockmount.....	1-8
1-7 51S-1B Receiver, Installation Details.....	1-9
2-1 Operating Controls	2-1
3-1 RF Input Circuits, Simplified Schematic Diagram	3-2
3-2 Block Diagram	3-7
4-1 Top Chassis, Alignment and Adjustment Locations (C712-14-P).....	4-4

list of illustrations (cont)

<i>Figure</i>	<i>Page</i>
4-2 Bottom Chassis, Alignment and Adjustment Locations (C712-15-P).....	4-5
4-3 RF and IF Transformer Terminal Identification (C712-26-2).....	4-6
4-4 Trimmer Capacitor Settings (C712-05-3).....	4-8
4-5 Receiver Gain Adjustment Test Setup	4-10
4-6 Band Indicator Bead Chain Stringing (C712-18-P).....	4-12
5-1 51S-1F in Rack Mount, Overall View	5-1
5-2 51S-1B with 350D-5 Base Shockmount, Overall View	5-2
6-1 51S-1() Receiver and 350D-5 Base Shockmount	6-7
6-2 Interconnecting Box Assembly.....	6-10
6-3 Receiver Subassembly.....	6-11
6-4 Power Supply.....	6-32
6-5 28-VDC Power Supply	6-34
6-6 RF Tuning Unit.....	6-37
6-7 Gear Train Assembly	6-43
6-8 Capacitor Assembly (A1, A4).....	6-46
6-9 Coil Assembly (A2, A5, A6).....	6-48
6-10 Coupling Coil Assembly (A3).....	6-50
6-11 Capacitor Assembly (A7).....	6-51
6-12 Crystal Oscillator Capacitor Assembly (A8).....	6-52
6-13 Trimmer Capacitor Assembly (A9).....	6-54
6-14 Crystal Assembly (A10)	6-55
6-15 350D-5 Base Shockmount	6-57
7-1 51S-1/1F Receiver, Schematic Diagram.....	7-1
7-2 51S-1A/1AF Receiver, Schematic Diagram.....	7-11
7-3 Turret and RF Section, Schematic Diagram.....	7-21
7-4 51S-1B Junction Box, Schematic Diagram (C712-38-2).....	7-25
7-5 51S-1B Output Circuit, Partial Schematic Diagram (C712-42-3).....	7-26

list of tables

<i>Table</i>	<i>Page</i>
1-1 Items Supplied with Receiver	1-10
1-2 Power Cable Kits Available for 51S-1/1F.....	1-10
3-1 51S-1 Crystal Utilization.....	3-5
4-1 Receiver Signal Levels.....	4-1
4-2 Voltage and Resistance Measurements.....	4-2
5-1 Tube and Semiconductor Complement.....	5-5
5-2 Available Accessories.....	5-6
5-3 51S-() Descriptions.....	5-7

section 1
installation

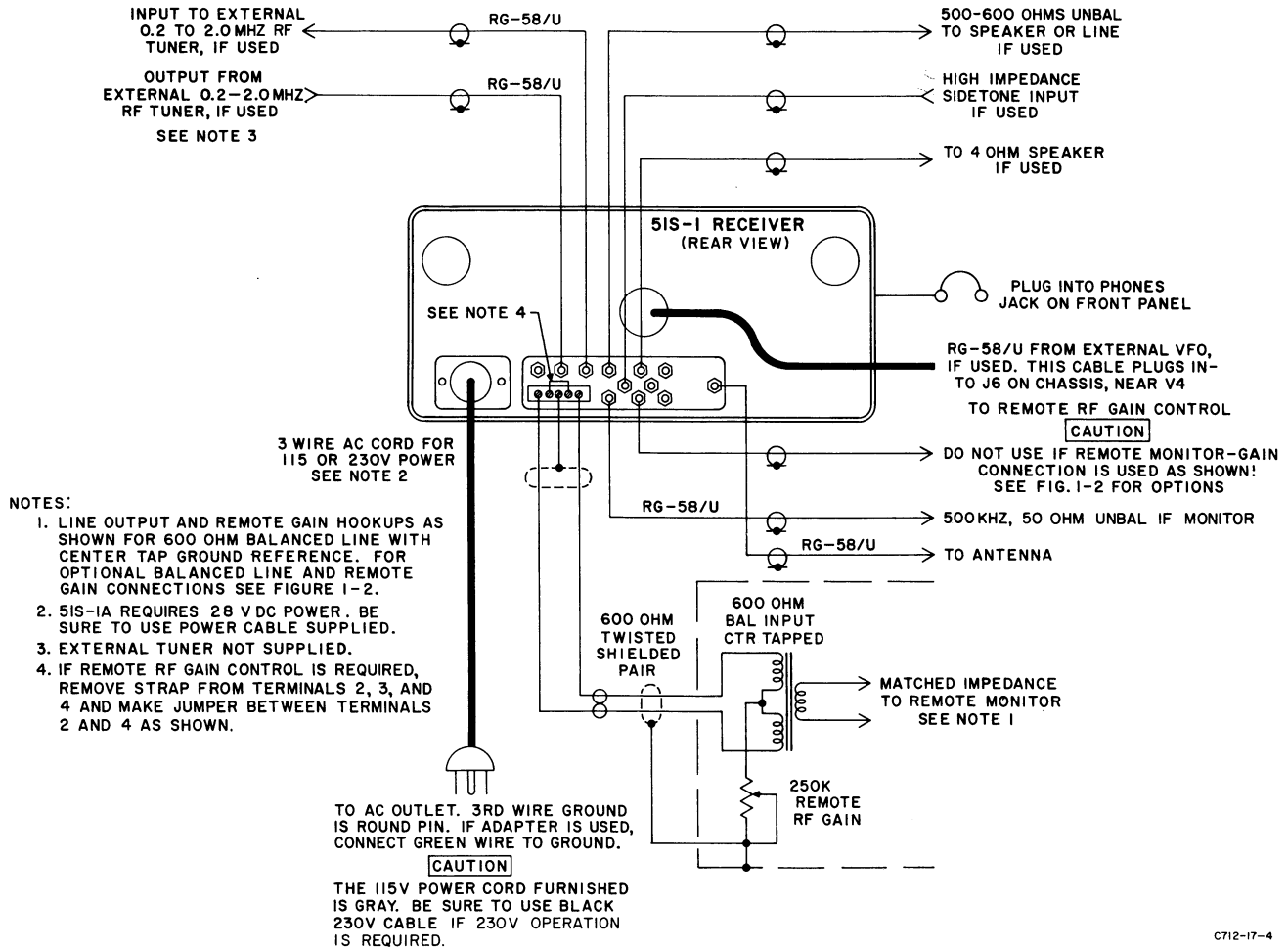

C712-17-4

Figure 1-1. External Connections to 51S-1/1A/1F/1AF

section 1

installation

1.1 UNPACKING

Carefully lift the 51S-1 out of the packing material. Examine the unit for visible damage. If the receiver has been damaged in shipment, save the carton and packing material, and notify the transportation company. Fill out and mail the guarantee card. Check that tubes and crystals are seated properly in their sockets. Check all controls and switches for freedom of action. A cloth bag, tied inside the receiver, contains small hardware, tools, and spare items. See tables 1-1 and 1-2.

1.2 MOUNTING AND CABLING FOR 51S-1/1A/1F/1AF

Connect 51S-1/1A/1F/1AF Receiver as shown in figures 1-1 and 1-2. Figures 1-3 and 1-4 show outline and mounting dimensions for 51S-1/1A and 51S-1/1A with 351E-4 Mount. Figure 1-5 shows outline and mounting dimensions for 51S-1F/1AF.

1.2.1 Power Cable

The power cable kits available for the 51S-1/1F are listed in table 1-2. For 115-volt operation, connect the gray ac power cable to the 51S-1/1F. Make sure that the key slot of the 9-pin cable connector is aligned with the key of the chassis connector. Plug the power cable into a 115-volt ac outlet. If the outlet is not equipped with a mating receptacle, use the power cable adapter, and ground the green wire of the adapter. For 230-volt operation, use the black ac cord to connect to a 230-volt ac outlet. For the 51S-1A/1AF, a 28-volt dc cord, with mating plug for the chassis connector, is furnished.

Caution

If both the 115-volt and 230-volt cables are on hand, be sure the correct cord is used for the

power source. If the 51S-1 is plugged into 230 volts ac with the gray cord, the receiver may be damaged. Use 1.5-ampere fuse for 115-volt operation, and a 0.75 ampere fuse for 230-volt operation.

1.2.2 Audio Outputs

Connect a 4-ohm speaker, equipped with a phono-type plug, to the jack marked 4Ω on the rear of the 51S-1. If the speaker is equipped with a line-to-voice-coil transformer, connect the phono plug to the jack marked 600Ω UNBAL on the rear of the receiver.

Earphones equipped with PL-55 type connector may be plugged into the jack marked PHONES on the front panel. Plugging in earphones automatically disables the speaker connected to the 4Ω jack. A speaker connected to the 600Ω UNBAL output will not be disabled by plugging earphones into the PHONES jack.

1.2.3 Antenna

The ANT jack on the rear of the 51S-1 is provided to connect a 52-ohm transmission line to the receiver. The transmission line should be equipped with a phono plug.

1.3 MOUNTING AND CABLING FOR 51S-1B

Figure 1-6 shows outline and mounting dimensions for 51S-1B with 350D-5 Base Shockmount. An aluminum mounting plate is fastened to the bottom of the 51S-1B instead of the rubber feet used on other 51S-1 series receivers. The 51S-1B mounts on the shockmount so that the rear flange of the mounting plate fits into a channel in the rear of the shockmount. Thumbnut operated clamps engage tabs on the front of the mounting plate to secure the receiver on the shockmount.

Figure 1-7 shows the junction box on the rear of the 51S-1B. The junction box provides military-type connectors for power, control, audio, and antenna. Figure 7-4 is a schematic diagram of the junction box.

1.4 SUPPLEMENTARY INSTALLATION DATA FOR 51S-1/1A/1F/1AF

1.4.1 If. Output

The 51S-1 Receiver is equipped with an IF OUT jack located on the rear of the chassis apron. Intermediate-frequency output from this jack is available for operation of an RTTY converter, oscilloscope, or other device requiring a 500-kHz if. input signal. The IF OUT jack mates with a phono plug.

1.4.2 External RF Gain

The EXT RF GAIN jack on the rear of the receiver provides means of connecting a remote gain control to the 51S-1. A cable connecting the receiver EXT RF GAIN jack with the remote location should be terminated with a 250K potentiometer connected as shown in figures 1-1 and 1-2. The minimum resistance position of the potentiometer will result in maximum receiver gain. When receiver gain is to be controlled in this manner, the RF GAIN on the front panel of the receiver should be left set at maximum (fully clockwise), and one of the options of figure 1-2 must be used. As shipped, J7 is jumpered to ground through T4 secondary. The strap on terminals 2, 3, and 4 of the rear apron terminal board must be removed when external rf gain is used and new jumpers made of wire for the options shown. Jack J7 must not be left open or ungrounded or the receiver will be muted.

1.4.3 Mute

The MUTE jack on the rear of the 51S-1 chassis provides connections for external standby-receive switching. The external switch may be contacts of a transmit-receive relay. For proper muting of the 51S-1, the contacts of a transmit-receive relay should be in closed position during receiving and open position during

transmitting. When muting is being used, the OFF-STBY-ON-CAL switch on the front panel of the 51S-1 must be in the STBY position.

1.4.4 Sidetone

The 51S-1 is equipped with a SIDETONE input jack on the rear of the chassis. Audio-frequency monitoring signals may be injected into this jack for all EMISSION switch settings except AM. The jack mates with a phono plug.

1.4.5 Line Output

The 600 Ω terminals of the terminal block on the rear of the 51S-1 provide a 600-ohm balanced output to match a telephone line or a remote monitoring arrangement. Refer to figures 1-1 and 1-2. Figure 1-2 shows various options for these connections.

1.4.6 External VFO Connection

An external vfo jack, J6, labeled EXT VFO, is located on the chassis near the vfo subassembly. This jack is a switching type which opens its contacts when a plug is inserted. With no plug in J6, the vfo signal is connected to the last mixer, but when an external signal is plugged in, the internal vfo signal is disconnected and the external signal is substituted. This allows plugging in an external stabilized master oscillator for improved stability, precise calibration, or fixed-channel selection purposes.

Note

When an external signal source is used, such as stabilized master oscillator or crystal-controlled oscillator, the injection frequency must be between 3.5 and 2.5 MHz. In addition, the 51S-1 must be tuned to the desired channel frequency after each change in injection frequency. Disconnect the vfo B+ line to prevent creation of a spurious response and shunt the output of the external signal source with a 220-mh rf choke to provide a low-resistance dc path for the cathode current of mixer V4A.

Jack J6 mates with a miniature phone plug, such as Electrocraft (manufacturer's catalog no.

200-2) or Switchcraft Inc., (manufacturer's catalog no. XA-7956); military-type plugs are MIL-F-3115 and MIL-F-642, respectively; Collins part numbers are 361-0051-00 and 361-0119-00, respectively.

1.4.7 Rejection Tuning

The Q-multiplier may become slightly detuned during shipping. Refer to paragraph 4.4.13 for alignment procedure.

1.5 SUPPLEMENTARY INSTALLATION DATA FOR 51S-1B

1.5.1 If. Output

The 51S-1B Receiver is equipped with an IF OUT jack located on the rear of the chassis apron. Intermediate-frequency output from this jack is available for operation of an RTTY converter, oscilloscope, or other device requiring a 500-kHz if. input signal. The IF OUT jack mates with a phono plug.

1.5.2 External RF Gain Control Line

The external rf gain control line on the 51S-1B is not connected to terminal 2 on TB1 as it is on other 51S-1 series receivers. A 100-ohm resistor terminates the external rf gain control line at J7.

1.5.3 Mute

Connector J101 on the 51S-1B junction box provides connections for external standby-receive

switching as shown in figure 7-4. The external switch may be contacts of a transmit-receive relay. For proper muting of the 51S-1B, the contacts of the transmit-receive relay should be in closed position during receiving and open position during transmitting. When muting is used, the OFF-STBY-ON-CAL switch on the front panel of the 51S-1B must be in the STBY position.

1.5.4 Sidetone

The 51S-1B is equipped with a SIDETONE input jack on the rear of the chassis. Audio-frequency monitoring signals may be injected into this jack for all EMISSION switch settings except AM. The jack mates with a phono plug.

1.5.5 Line Output

Connector J101 on the 51S-1B junction box provides connections for a 150-ohm interphone line as shown in figure 7-4.

1.5.6 External VFO Connection

Provisions for connection of an external frequency standard to the 51S-1B are the same as those described in paragraph 1.4.6 for other 51S-1 series receivers.

1.5.7 Rejection Tuning

The Q-multiplier may become slightly detuned during shipping. Refer to paragraph 4.4.13 for alignment procedure.

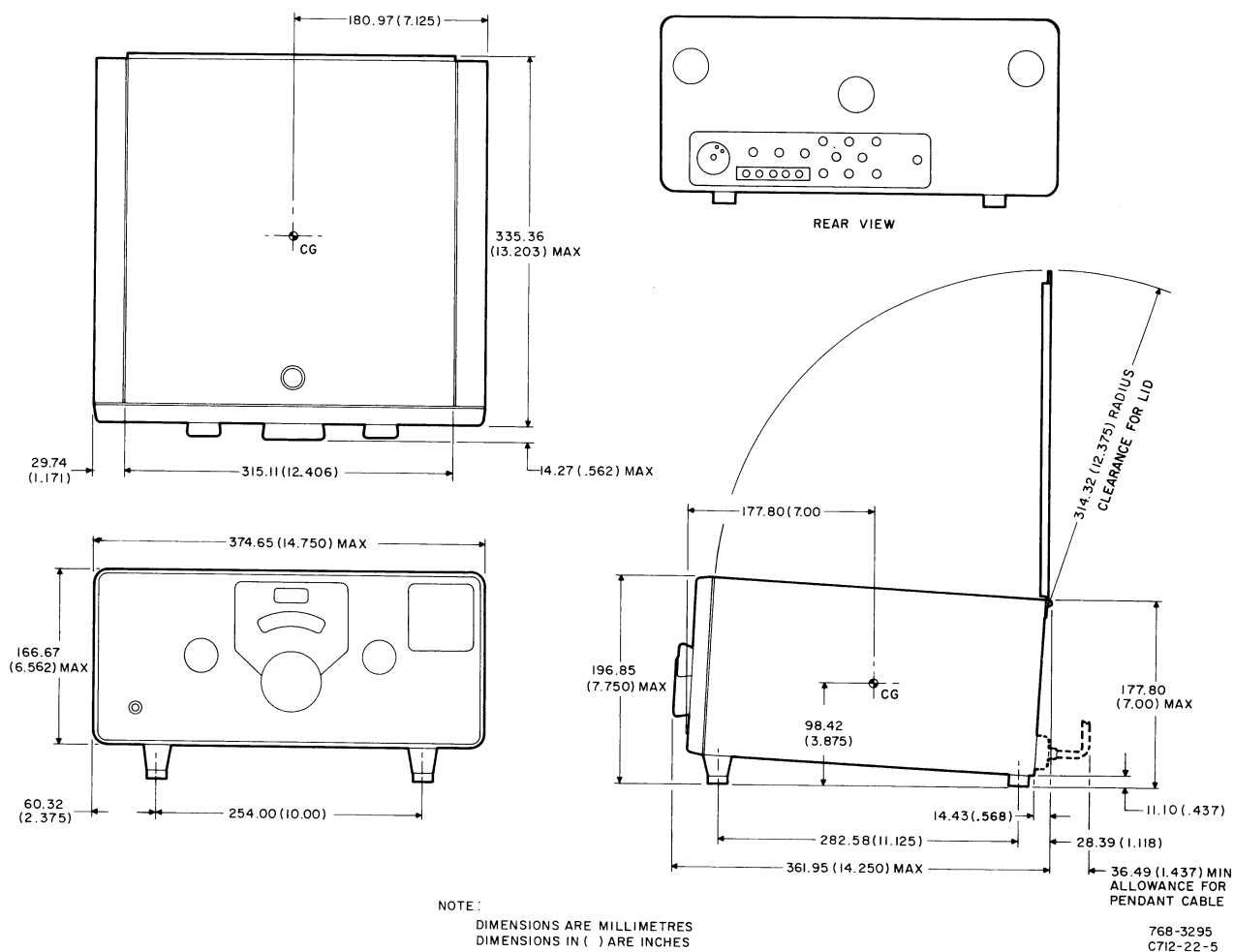
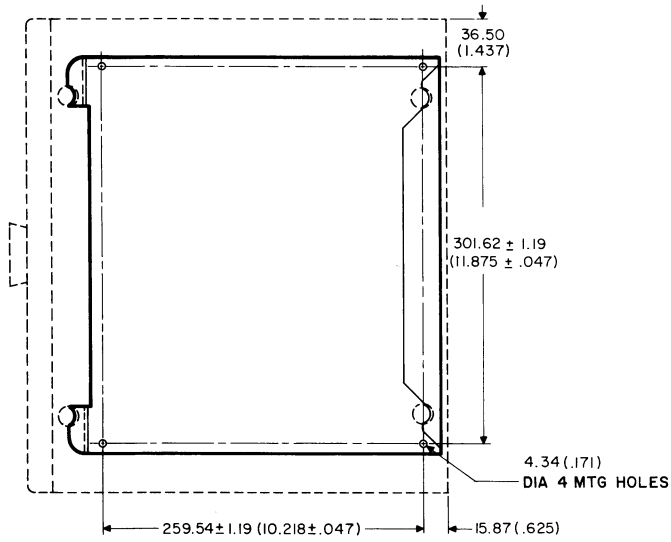

Figure 1-3. 51S-1/1A Receiver, Outline and Mounting Dimensions

section 1
installation



VIEW OF MOUNTING TRAY

NOTE:
 DIMENSIONS ARE IN MILLIMETRES
 DIMENSIONS IN () ARE INCHES

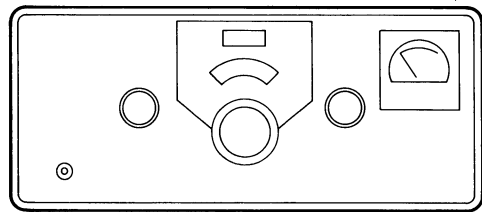

FRONT VIEW

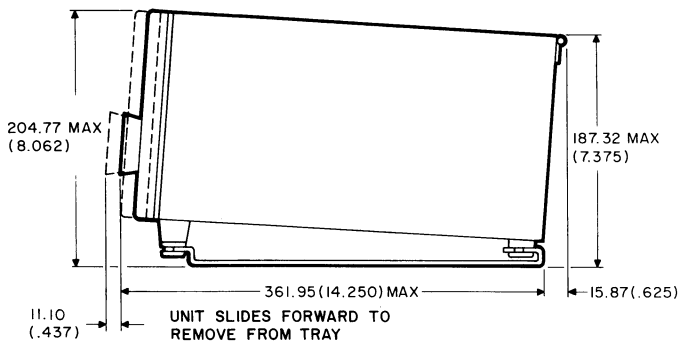

SIDE VIEW MOUNTED

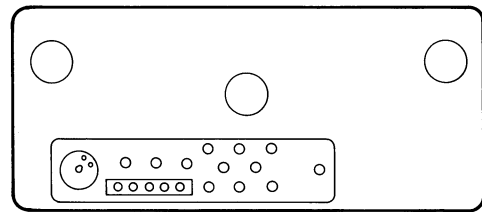

REAR VIEW

Figure 1-4. 51S-1/1A Receiver, Outline and Mounting Dimensions with 351E-4 Mount

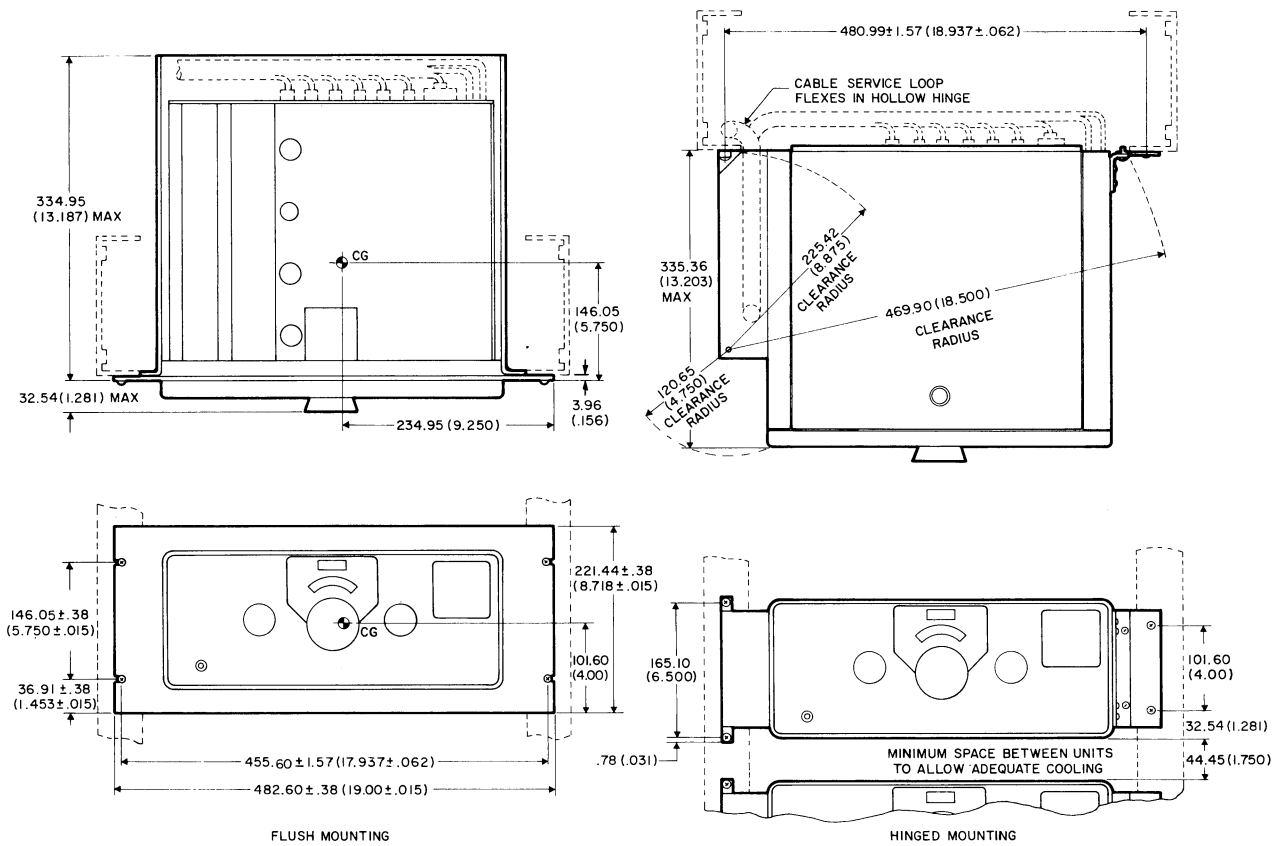

NOTE:
DIMENSIONS ARE MILLIMETRES
DIMENSIONS IN () ARE INCHES

768-3297
C712-23-5

Figure 1-5. 51S-1F/1AF Rack Mount and 51S-1/1A Hinged Mount, Outline and Mounting Dimensions

section 1
installation

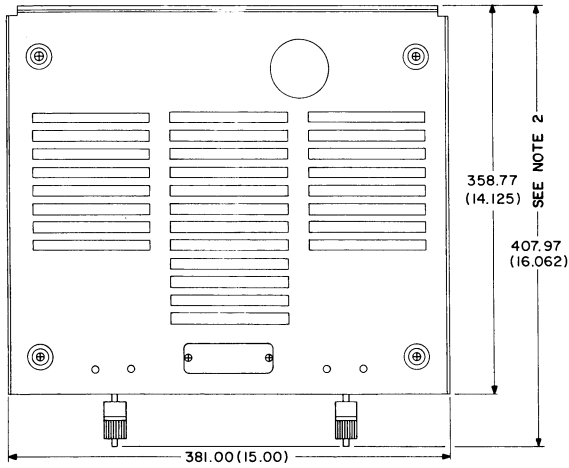

SHOCKMOUNT FEET DIMENSIONS

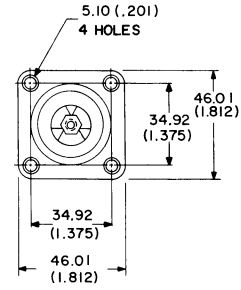

- NOTES:
1. MAXIMUM SWAY FOR SHOCKMOUNT TRAY, LOADED, IS 9.52 (.375)
 2. THIS DIM. APPLIES ONLY WHEN ADAPTER PLATE IS MOUNTED ON SHOCKMOUNT TRAY.
 3. UNIT WT ACT. .77 kg (1.70 LB.)
 4. DIMENSIONS ARE IN MILLIMETRES
 DIMENSIONS IN () ARE INCHES

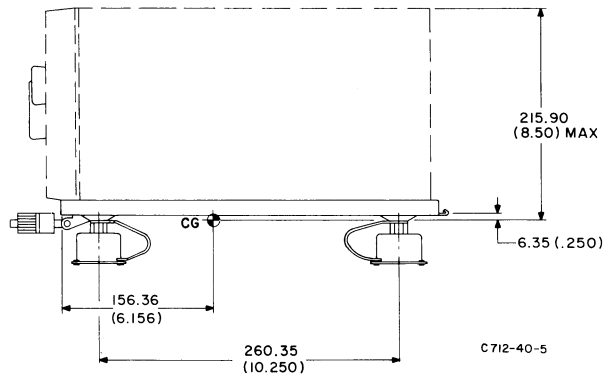
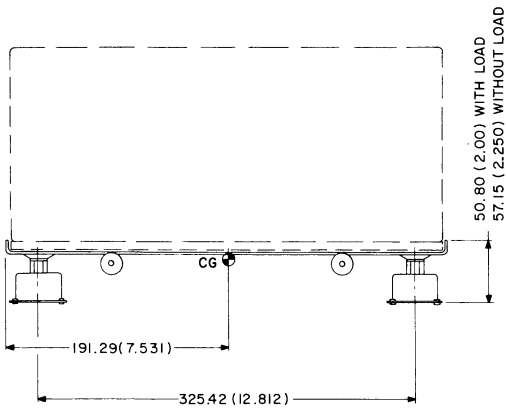

Figure 1-6. 51S-1B Receiver, Outline and Mounting Dimensions with 350D-5 Base Shockmount

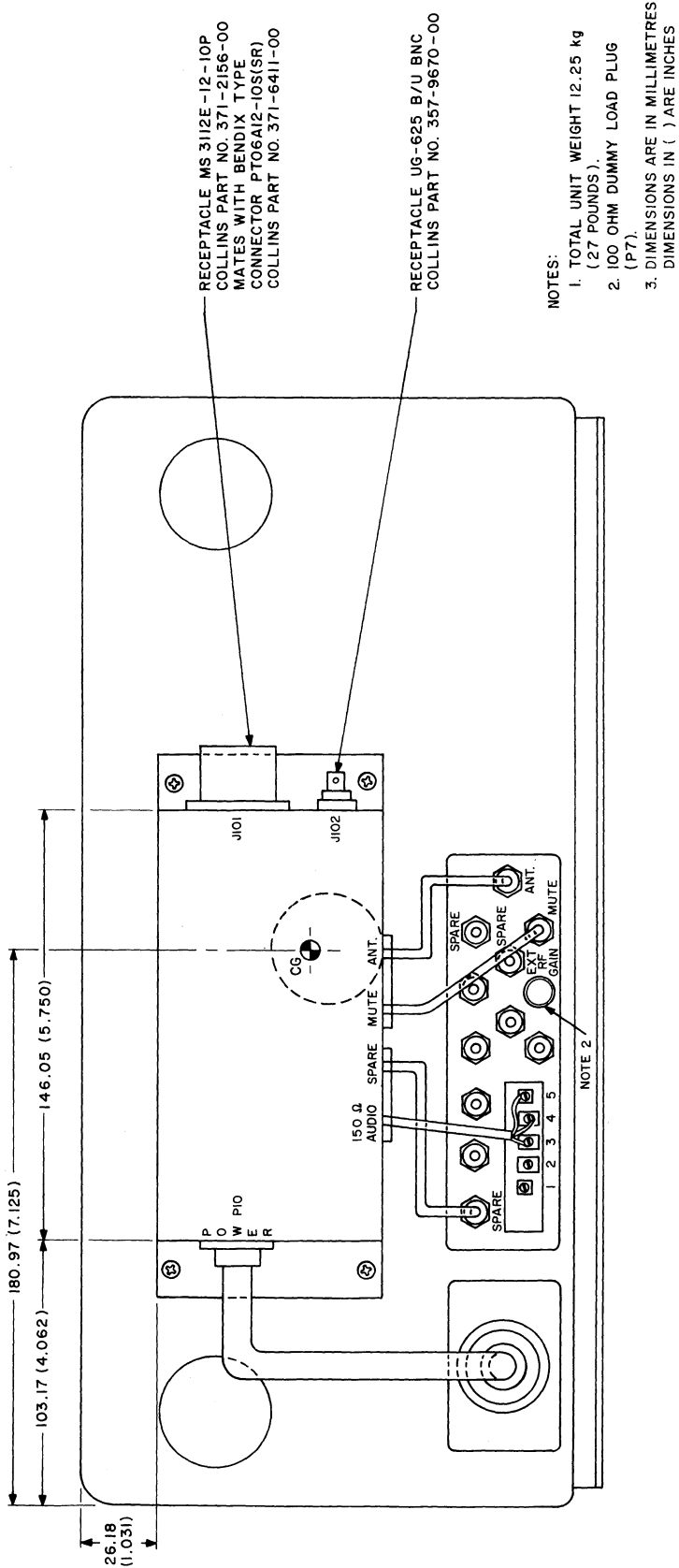
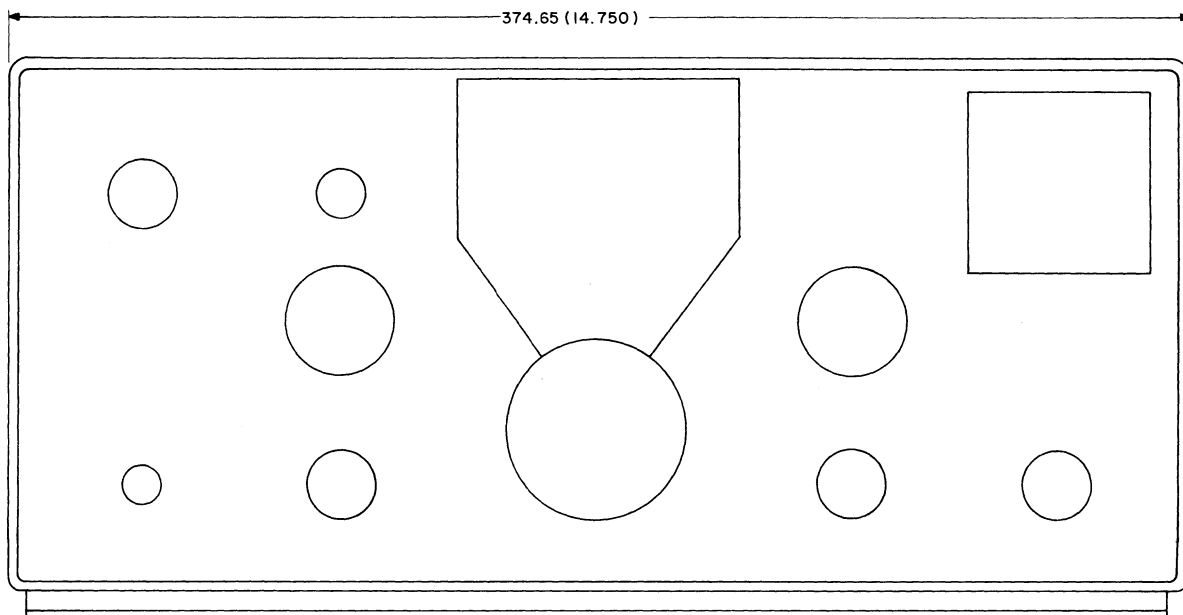
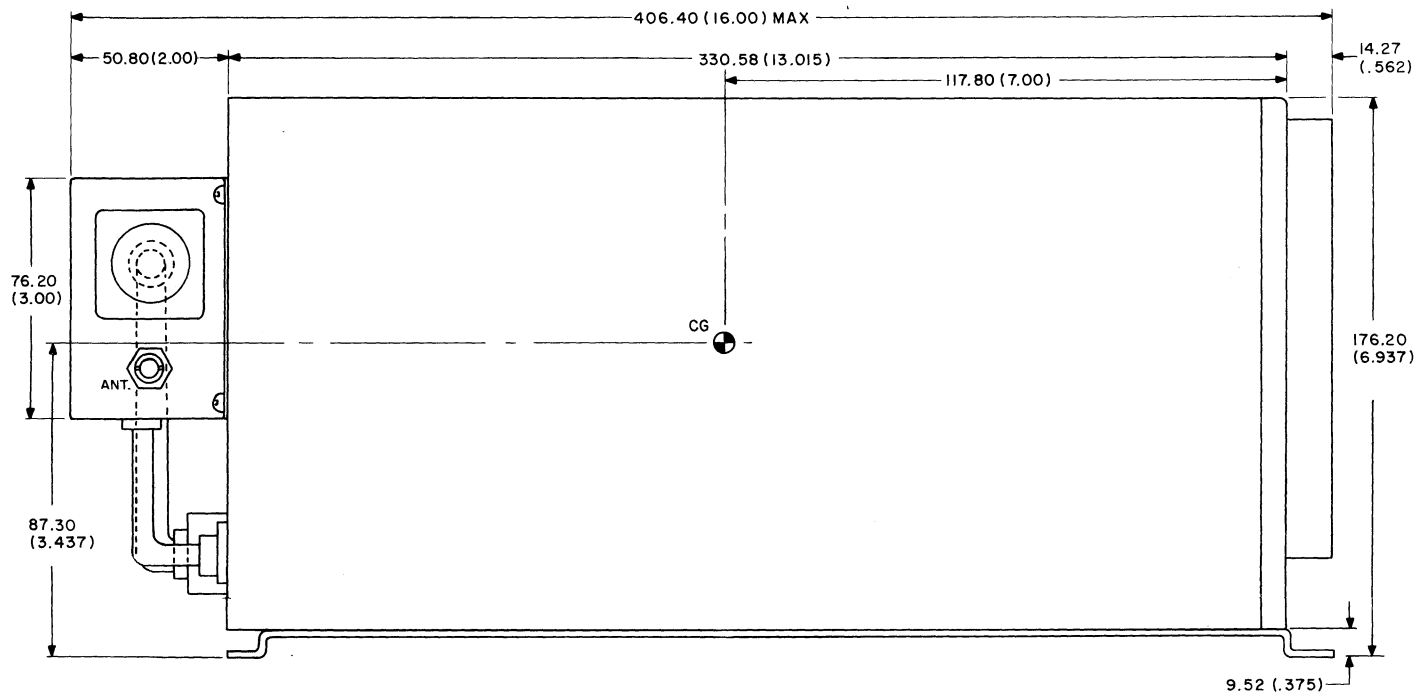

Figure 1-7. 51S-1B Receiver, Installation Details

C712-39-5

section 1
installation



section 1
installation

Table 1-1. Items Supplied with Receiver

QUANTITY	WITH MODEL	ITEM DESCRIPTION	COLLINS PART NUMBER
1	*51S-1/1F/1B	Power cable kits, 115/230 volts ac	See table 1-2
1	51S-1A/1AF	Power cable, 28 volts dc	548-8245-00
1	51S-1A/1AF	Fuse, 6 amperes	264-4100-00
1	51S-1/1A/1F/1AF/1B	Bristol wrench #4	024-2900-00
1	51S-1/1A/1F/1AF/1B	Bristol wrench #6	024-9730-00
1	51S-1/1A/1F/1AF/1B	Bristol wrench #6	024-0167-00
1	51S-1/1A/1F/1AF/1B	Bristol wrench #8	024-0019-00
6	51S-1/1A/1F/1AF/1B	Phono plugs	361-0062-00
1	51S-1/1A/1F/1AF/1B	6-volt pilot lamp bulb #47	262-3240-00
1	51S-1/1A/1F/1AF/1B	6-volt pilot lamp bulb #44	262-3220-00
4	51S-1F/1AF	12 24 x 5/8-inch screws	348-0008-00
4	51S-1F/1AF	10 32 x 1/2-inch screws	319-0165-00
4	51S-1F/1AF	Finishing washers	310-0092-00
4	51S-1F/1AF	Finishing washers	310-0086-00
1	51S-1/1A/1F/1AF/1B	Alignment tool	547-2796-002
1	51S-1/1A/1F/1AF/1B	Instruction book	523-0097-000
*115-volt ac power cable kit, CPN 554-7055-00, is supplied with 51S-1B.			

Table 1-2. Power Cable Kits Available for 51S-1/1F

QUANTITY	DESCRIPTION	COLLINS PART NUMBER
115-VOLT AC POWER CABLE KIT		554-7055-00
1	Power cable	547-2795-00
1	Adapter plug	368-0138-00
2	Fuse, 1.5 amperes	264-0007-00
230-VOLT AC POWER CABLE KIT		554-7056-00
1	Power cable	547-2674-00
3	Fuse 0.75 ampere	264-4270-00

section 2

operation

2.1 GENERAL

Make sure that the 51S-1 is connected to the proper power source. (See installation section.) Check to see that the antenna and speaker (or earphones) are connected to the proper jacks of the 51S-1.

2.2 FREQUENCY READING

Frequency is read on the 51S-1 by adding the indications of the megahertz counter, tenth

megahertz counter, and kilohertz dial. See figure 2-1. The frequency indicated is 5.295 megahertz.

2.3 SINGLE-SIDEBAND RECEPTION

- a. Turn the OFF-STBY-ON CAL switch to the ON position.
- b. Turn the MEGACYCLES control to obtain an indication on the megahertz counter corresponding to the desired band.

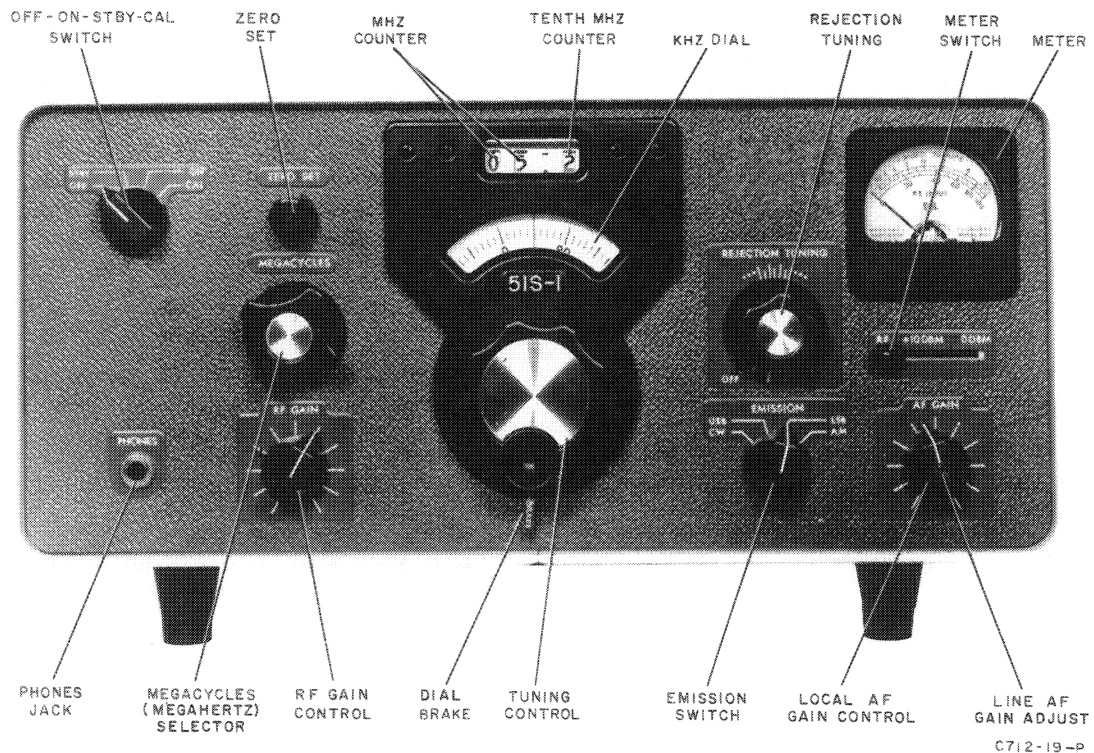

Figure 2-1. Operating Controls

- c. Turn the RF GAIN control fully clockwise.
- d. Move the EMISSION switch to USB for upper sideband reception or to LSB for lower sideband reception.
- e. Set the AF GAIN control for a comfortable listening level.
- f. Turn the tuning knob to obtain the most natural-sounding audio output.
- g. Adjust the RF GAIN control to the position that yields the best reception to background noise ratio.
- h. Readjust the local AF GAIN control if necessary.

An interfering heterodyne may be tuned out by adjusting the REJECTION TUNING control for minimum interference.

Relative rf input levels (signal strengths) may be observed by moving the RF - +10 DBM - 0 DBM selector to RF position. To adjust the LINE AF GAIN, set the meter switch to the 0 or 10 DBM position and set the LINE AF GAIN adjust to the desired level. The LINE AF GAIN adjust is a screwdriver adjustment located in the center of the local AF GAIN control knob (see figure 2-1).

2.4 CW RECEPTION

- a. Move the OFF-STBY-ON-CAL switch to ON position.
- b. Turn the MEGACYCLES control to obtain an indication on the megahertz counter corresponding to the desired band.
- c. Turn the RF GAIN control to fully clockwise.
- d. Move the EMISSION switch to USB position. If interference is present, move the EMISSION switch to CW for greater selectivity.
- e. Tune in the signal by turning the tuning knob. If the EMISSION switch is in the CW

position, tune for a definite peak in signal strength.

- f. Turn the AF GAIN control to approximately 12 o'clock position, and adjust the RF GAIN control for a comfortable listening level.

2.5 AM RECEPTION

- a. Move the OFF-STBY-ON-CAL switch to ON position.
- b. Turn the MEGACYCLES control to obtain an indication on the megahertz counter corresponding to the desired band.
- c. Turn the RF GAIN control fully clockwise.
- d. Move the EMISSION switch to AM position.
- e. Set the local AF GAIN for a comfortable listening level.
- f. Turn the tuning knob to obtain the best reception.
- g. Adjust the RF GAIN control to obtain the best reception to background noise ratio.
- h. Readjust the local AF GAIN control if necessary. Adjust line AF GAIN control to obtain desired line level.

An interfering heterodyne may be tuned out by adjusting the REJECTION TUNING control for minimum interference.

Note

During AM reception (EMISSION switch in AM position) with an interfering signal present, the resulting heterodyne may be tuned out by either of two settings of the REJECTION TUNING control. However, only one of the settings will allow the desired signal to be detected properly. Select the REJECTION TUNING setting which yields the better intelligibility.

If interference and/or selective fading are present, better reception of AM signals may be obtained by moving the EMISSION switch to USB or LSB position, zero beating the desired

carrier and proceeding as in paragraph 2.3, steps f, g, and h. Move the EMISSION switch to either USB or LSB, whichever results in the better reception.

2.6 CALIBRATION

a. Move the OFF-STBY-ON-CAL switch to CAL position.

b. Move the EMISSION switch to USB or LSB.

c. Turn the tuning knob to obtain an indication of 0 kHz on the kilohertz dial. (The megahertz counter and tenth megahertz counter reading should be close to the desired frequency of operation.)

d. Turn the tuning knob to obtain an indication of zero beat.

e. Using the ZERO SET knob, move the hair-line to 0 on the kilohertz dial.

f. Return OFF-STBY-ON-CAL switch to ON position.

2.7 DIAL BRAKE

a. To hold the tuning knob at a particular frequency, move the dial brake mechanism, located under the tuning knob, in a counter-clockwise direction.

b. To unlock the tuning knob, turn the dial brake mechanism in a clockwise direction.

section 3

principles of operation

3.1 GENERAL

Figure 3-2 is a block diagram of the 51S-1, and figure 7-1 is a schematic diagram of the 51S-1. Figure 7-2 is a schematic diagram of the 51S-1A. Figure 7-3 is a partial schematic of the receiver, showing the complete front-end switching arrangement. The 51S-1 is a dual- or triple-conversion communications receiver which operates in the range of 0.2 to 30 megahertz. The 0.2- to 2.0-MHz portion of the coverage is intended for laboratory applications and broadcast monitoring. In this range, internally generated spurious whistles occur at 333 kHz, 666 kHz, 1000 kHz, 1500 kHz, and 2000 kHz. Triple conversion is used for the 0.2- to 7.0-MHz bands, and double conversion is used for the 7.0- to 30.0-MHz bands. For 7.0- to 30.0-MHz operation, the 14.5- to 15.5-MHz bandpass network and second mixer are bypassed.

The 51S-1 is basically a 2.0- to 30.0-MHz receiver with a built-in low-frequency converter. The tuning mechanism, counter dials, and turret are arranged so the two lowest bands, 0.2 to 1.0 MHz and 1.0 to 2.0 MHz, use the 28.0- to 29.0- and the 29.0- to 30.0-MHz bands of the receiver as a variable if. (conversion) frequency. As the megahertz counter is reduced in setting below 2.0 MHz (lowest band on the turret), a segment switch, S6, connects the low-frequency converter and its bandpass filter between the antenna and the turret input, which is now the 29.0- to 30.0-MHz band. When the megahertz counter setting is reduced below 1.0 MHz, the segment switch, S6, maintains the low-frequency converter connection, but the turret is changed to the 28.0- to 29.0-MHz band. In this manner, the 28 positions of the turret plus two positions of overtravel provide 30 bands, each 1 megahertz wide. The 0.2-MHz limitation of the lowest band is a function of the frequency roll-off in the bandpass filter and mixer considerations.

3.2 CIRCUIT DESCRIPTIONS

3.2.1 RF Amplifier

Signals from the antenna are fed from J1 through S6 contacts to an impedance-matching transformer, L30. The output of L30 is coupled to the first section of the double-tuned input network. Refer to figure 3-1. The double-tuned input circuits are composed of C40, L33, L32, L31, C71, L69, L68, L67, and the components mounted upon turret wafers A1 through A5. All rf section components and turret wafers are shown in figure 7-3. The first section of this network is tuned by C40, C_p , $L_p - L_m$ and L33-L32-L31. For any position of the turret, L33, L32, L31, and C40 are in the circuit, and the band changing is accomplished by connecting the turret-mounted components in shunt. The tuning slug of L32 is coupled mechanically to the tuning control of the receiver, and is varied to accomplish tuning throughout the 1-MHz band. The second section of the network is tuned by C71, C_n , $L_n - L_m$ and L69-L68-L67. The tuning slug of L68 is ganged to the tuning control of the receiver to accomplish tuning in the same manner as that of L32 in the first section of the network. The turret-mounted components are selected by the MEGACYCLES control. This control positions the turret wafers so that the proper set of components is connected into the circuit according to the megahertz information on the counter dial. Coupling between the two sections of the input network is provided by mutual inductance L_m . The output network consists of a single-tuned system using a band-switching and tuning scheme similar to that of the input network.

3.2.2 First Mixer

The first mixer, V2A, is a triode. The rf signal is fed to the grid, and the hf crystal oscillator signal is injected at the cathode.

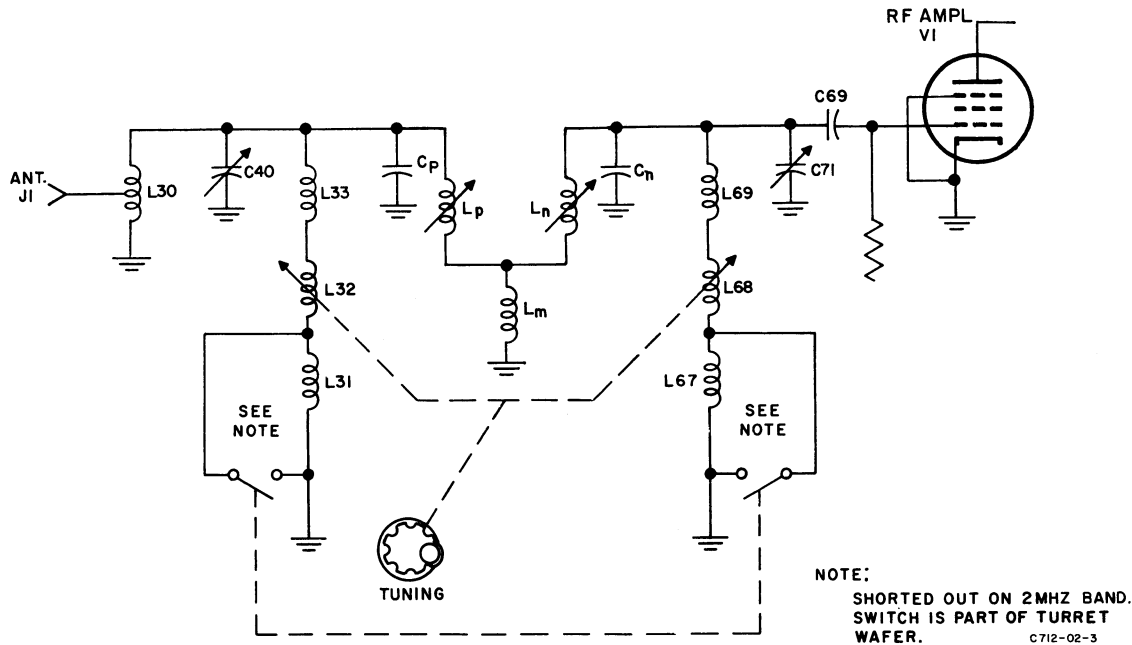

Figure 3-1. RF Input Circuits, Simplified Schematic Diagram

The output network consists of a 14.5- to 15.5-MHz bandpass filter for 2- to 7-MHz operation and a 3- to 2-MHz variable, triple-tuned network for 7- to 30-MHz operation. The slugs of the 3- to 2-MHz variable if. network inductors are coupled mechanically to the tuning control of the receiver and tracked with the slug-tuned inductors in the rf circuits to produce the 1-MHz coverage for each band.

3.2.3 Second Mixer

During 2- to 7-MHz operation, the second mixer, triode V3A, uses a 3- to 2-MHz variable if. for its output network. This is the same output network that is used by the first mixer during 7- to 30-MHz operation. The signal from the first mixer plate is fed through the 14.5- to 15.5-MHz bandpass filter network, T12 and T13, to the grid of the second mixer. The 17.5-MHz oscillator signal is injected into the cathode circuit of this mixer. The second mixer is inoperative during 7- to 30-MHz operation.

3.2.4 Third Mixer

The third mixer, pentode V4A, receives its input signal from the 3- to 2-MHz variable if. network. The input signal from the first or second mixer is fed to the grid of the third

mixer and the vfo signal is injected into its cathode. An external vfo signal may be injected through J6 if external frequency control is desired. Such an external injection signal might also be a selected crystal oscillator frequency if precise fixed channel tuning is desired. In such a case, the tuning dial would have to be set to the channel frequency in order to properly resonate all the rf and if. gang-tuned circuits.

The output network of the third mixer is selected with the EMISSION switch on the front panel. In USB and LSB positions, mechanical filters FL2 and FL3 are used. Depending on the particular model of the receiver or the options selected, (Section 5, Specifications) these mechanical filters provide either a 2.75-, 2.4-, or 3.1-kHz bandwidth for single-sideband reception on upper or lower sideband, respectively. The CW position of the EMISSION switch selects a crystal filter, FL4. The crystal filter provides an 800-Hz (optional 300-Hz) bandwidth for reception of CW signals. The AM position of the EMISSION switch selects a network composed of two lightly coupled 500-kHz if transformers, T14 and T15, which provides a bandwidth of 5 kHz for reception of amplitude-modulated signals. (Optionally, T14 and T15 can be replaced by a mechanical filter providing 6-kHz bandwidth.)

3.2.5 First IF Amplifier

The first if. amplifier, pentode V5, receives its input signal from the third mixer through one of the four selective networks described in paragraph 3.2.4. The output signal is coupled to the Q-multiplier through if. transformer T1.

3.2.6 Q-Multiplier

The Q-multiplier, V6, is a twin triode. The first triode section is a cathode follower, the output of which is coupled to the cathode of the second triode section. When REJECTION TUNING is being used, the signal from the plate of the second triode is coupled through a parallel-tuned circuit to the grid of the second if. amplifier. The parallel-tuned circuit consists of L108, C145, and C146 and a small voltage sensitive capacitor. These components, plus R33 and R34, form a bridged-T rejection notch filter. The end of the parallel-tuned circuit, away from the plate of the second triode section, is coupled to the grid of the second triode. This feedback arrangement forms a Q-multiplier. The Q of L108 is 250. The feedback loop has a gain of 10, resulting in an overall Q of 2500 and a rejection notch depth of not less than 40 db. Turning the REJECTION TUNING control fully counterclockwise deactivates the rejection network by forward biasing capacitance diode C315 into conduction.

3.2.7 Second IF Amplifier

The second if. amplifier, pentode V7, receives its input signal from the Q-multiplier network. The output network of the second if. amplifier is if. transformer T2. The secondary of T2 is coupled to the third if. amplifier, V8, and cathode follower V11A.

3.2.8 Third IF Amplifier

The third if. amplifier, V8, receives its input signal from the second if. amplifier through transformer T2. The third if. amplifier output is coupled to the product demodulator through if. transformer T3 and to the AM detector through C158.

3.2.9 Product Demodulator

The product demodulator is composed of CR1, CR2, CR3, and CR4 in a diode-ring configuration. Signal from the beat-frequency oscillator, V17, is injected into the product demodulator at the junction of R135 and R136. The audio output is fed to the SSB/CW preamplifier, Q1. The bfo supplies a reinserted carrier to replace the suppressed carrier of the SSB signal. The demodulator functions as a mixer, and its output is a full-wave rectified signal consisting of the if. and bfo signals plus their mixing products. C161, L123, and C310 form a low-pass filter that passes the if. and bfo mixing difference frequency and blocks the rest of the demodulator output. The mixing difference frequency is the desired audio signal.

3.2.10 SSB/CW Preamplifier

The output impedance of the diode demodulator is approximately 600 ohms. Transistor Q1 provides impedance match and gain between the product demodulator and the following audio amplifier grid. The SSB/CW preamplifier is an npn transistor, connected in a common emitter configuration. Audio signals from the product demodulator and sidetone signals from the cathode follower, V11B, are coupled to the base of Q1. The SSB/CW preamplifier output signal is coupled from the collector of Q1 through C165 to switch S2C. During SSB and CW operation, the contacts of S2C connect the audio output signal to first local af amplifier, V14B, and the first line amplifier, V14A.

3.2.11 Audio Amplifiers

The 51S-1 includes two, two-stage, audio-frequency amplifiers. The local amplifier, consisting of V14B and V12, provides audio power to local headphones, speaker, or phone patch. The line amplifier, consisting of V14A and V13, provides power for a 600-ohm remote line.

Note

The line output impedance of 51S-1B is 150 ohms. Figure 7-5 is a partial schematic diagram of the 51S-1B output circuit.

The first local and the first line af amplifiers obtain input signal from either the SSB/CW preamplifier, Q1, or from AM detector CR15. The signal source, Q1 or CR15, is selected by contacts of the EMISSION switch, S2. The first local and first line af amplifiers drive their respective second local and line amplifiers V12 and V13. The line amplifier distortion is reduced by use of negative feedback from output transformer T4 to the cathode of V14A.

3.2.12 Low-Frequency Mixer

For receiving signals in the 0.2- to 2.0-MHz range, the 51S-1 uses a low-frequency mixer, V10A-V16A, and converts the signal to the 28- and 29-MHz bands. The low-frequency input to the mixer is passed through a bandpass filter, and the output of the mixer is tuned by the turret and slug-tuned circuits. External tuners for low-frequency operation may be used. Jacks J14 and J13 on the rear apron are provided for this use. When an external low-frequency tuner is used, the jumper between J14 and J13 must be removed. See figure 7-1.

3.2.13 Oscillators

The calibration oscillator, V16B, is a crystal-controlled oscillator operating at 100 kilohertz. Variable capacitor C227 trims the frequency of the oscillator. The output of the calibration oscillator is coupled to the antenna jack, J1.

The low-frequency crystal oscillator, V10B, uses a 14-MHz crystal. The plate circuit of this oscillator is tuned to the second harmonic of the crystal. The low-frequency crystal oscillator operates only when the 51S-1 is receiving signals in the 0.2- to 2.0-MHz bands. The output of this oscillator is coupled to the low-frequency balanced mixer, V10A and V16A. Capacitor C2 trims the crystal oscillator to frequency.

The high-frequency crystal oscillator, V2B, operates on all bands. Frequency of oscillator operation is determined by one of sixteen crystals mounted on a wafer in the turret (see

table 3-1). The proper crystal is selected by positioning the band-switch MEGACYCLES control. Individual turret-mounted piston trimmer capacitors trim each crystal to frequency.

The 17.5-MHz oscillator, V3B, is crystal controlled. This oscillator operates only when the 51S-1 is operating in the 2- to 7-MHz range. The crystal may be trimmed to frequency by variable capacitor C233.

The variable-frequency oscillator is a Collins 70K-7 permeability-tuned oscillator. The frequency of this unit is varied by changing the inductance of L501. This change of inductance is accomplished by turning the 51S-1 tuning knob which is coupled mechanically to the slug of L501. The output of the oscillator tube, V15, is coupled to the cathode of the third mixer through T501.

The beat-frequency oscillator, V17, is a 500-kHz crystal-controlled oscillator which operates only when the EMISSION switch of the 51S-1 is in USB, LSB, or CW position. No beat-frequency oscillator is needed for AM operation. The output of the bfo is coupled to the product demodulator. There is no provision for trimming the bfo frequency.

3.2.14 Special Circuits

Cathode follower V11A receives if. excitation from the second if. amplifier. The output of this cathode follower is fed to agc amplifier V9. The output of the agc amplifier is coupled to the agc rectifier, CR14, and to the if. output jack, J9.

The agc rectifier, CR14, rectifies the if. signal from agc amplifier V9. The dc output from the agc rectifier is used for automatic gain control of the rf and if. amplifiers.

Cathode follower V11B receives sidetone signal from J8 on the rear apron of the 51S-1. The sidetone audio output from this stage is fed to the SSB/CW preamplifier, Q1.

Diode CR16 in the rf amplifier grid return line is used to stabilize the agc circuit and prevent agc pumping.

Diode CR17 suppresses transients occurring on the rf gain control bus during mute on-off switching.

Remote gain gate V4B presents a high-impedance isolation between the remote gain line and the agc circuit. This prevents the low-impedance remote gain circuit and the bias supply from loading the high-impedance agc circuits.

Table 3-1. 51S-1 Crystal Utilization

RECEIVER FREQUENCY RANGE IN MEGAHERTZ	TURRET CRYSTAL		HF OSCILLATOR OUTPUT (MHz)	17.5 MHz OSCILLATOR	LF CRYSTAL OSCILLATOR (2 x 14 MHz = 28 MHz)
	SYMBOL	FREQUENCY (MHz)			
0.2- 1.0	Y20	10.333	31.00	Off	On
1.0- 2.0	Y12	16.0	32.00	Off	On
2.0- 3.0	Y1	12.5	12.50	On	Off
3.0- 4.0	Y2	11.5	11.50	On	Off
4.0- 5.0	Y3	10.5	10.50	On	Off
5.0- 6.0	Y4	9.5	9.50	On	Off
6.0- 7.0	Y5	8.5	8.50	On	Off
7.0- 8.0	Y6	10.0	10.00	Off	Off
8.0- 9.0	Y7	11.0	11.00	Off	Off
9.0- 10.0	Y8	12.0	12.00	Off	Off
10.0- 11.0	Y9	13.0	13.00	Off	Off
11.0- 12.0	Y10	14.0	14.00	Off	Off
12.0- 13.0	Y11	15.0	15.00	Off	Off
13.0- 14.0	Y12	16.0	16.00	Off	Off
14.0- 15.0	Y5	8.5	17.00	Off	Off
15.0- 16.0	Y13	9.0	18.00	Off	Off
16.0- 17.0	Y4	9.5	19.00	Off	Off
17.0- 18.0	Y6	10.0	20.00	Off	Off
18.0- 19.0	Y3	10.5	21.00	Off	Off
19.0- 20.0	Y7	11.0	22.00	Off	Off
20.0- 21.0	Y2	11.5	23.00	Off	Off
21.0- 22.0	Y8	12.0	24.00	Off	Off
22.0- 23.0	Y1	12.5	25.00	Off	Off
23.0- 24.0	Y9	13.0	26.00	Off	Off
24.0- 25.0	Y18	13.5	27.00	Off	Off
25.0- 26.0	Y10	14.0	28.00	Off	Off
26.0- 27.0	Y19	14.5	29.00	Off	Off
27.0- 28.0	Y11	15.0	30.00	Off	Off
28.0- 29.0	Y20	10.333	31.00	Off	Off
29.0- 30.0	Y12	16.0	32.00	Off	Off

service instructions

4.1 PREPARATION FOR SERVICING

4.1.1 General

Included in this section are signal tracing procedures, alignment and adjustment procedures, voltage and resistance measurements, and replacement procedures. If any soldered parts are removed or replaced at terminals to which any diode or transistor is connected, be sure to attach an alligator clip to the diode or transistor lead. This clip acts as a heat sink to protect the diode or transistor.

Internally generated spurious signals may result from improper placement of certain components and rf leads in the hf oscillator, 17.5-MHz oscillator, and mixer compartments. Maintain proper lead dress and component place-

ment when probing in these compartments. Except for the vfo alignment (paragraph 4.4.14), it is recommended that servicing of the vfo should be performed only by authorized service agencies.

4.1.2 Chassis Removal From Cabinet

- a. Disconnect the power plug and all connections to the rear panel jacks.
- b. Lift the lid, and remove the two flat screws located at the front edge of the cabinet. (Do not remove the two outer screws.)
- c. Remove the four mounting feet and the screw between the rear feet from the bottom of the receiver. (On the 51S-1B, remove the five screws from the bottom of the receiver.)

Table 4-1. Receiver Signal Levels

TEST POINT	TEST POINT FREQUENCY	SIGNAL LEVEL	REFERENCE
J8	1000 Hz	0.22 volt	1-watt af output
V12-1	1000 Hz	6.0 volts	1-watt af output
V14-2	1000 Hz	0.2 volt	1-watt af output
V13-1	1000 Hz	0.45 volt	10 milliwatts in 600 ohms
V14-7	1000 Hz	0.18 volt	10 milliwatts in 600 ohms
Above measurements with ac vtvm from test point to ground, and audio oscillator connected at test point.			
V8-1	500 kHz	35,000 microvolts	1-watt af output
V7-1	500 kHz	5000 microvolts	Agc threshold
V6-2	500 kHz	15,000 microvolts	Agc threshold
V5-1	500 kHz	450 microvolts	Agc threshold
V4-2	*2.9 MHz	200 microvolts	Agc threshold
V2-9	*6.1 MHz	30 microvolts	Agc threshold
V2-9	**14.1 MHz	100 microvolts	Agc threshold
V3-9	*14.6 MHz	100 microvolts	Agc threshold
For following measurements, signal generator and 51S-1 must be tuned to same frequency.			
V1-1	14.1 MHz	4.0 microvolts	Agc threshold
V1-1	6.1 MHz	1.5 microvolts	Agc threshold
J1	14.1 MHz	1.5 microvolts	Agc threshold
J1	6.1 MHz	0.5 microvolts	Agc threshold
*Radio tuned to 6.1 MHz			
**Radio tuned to 14.1 MHz			

d. From the rear, push the receiver chassis forward until the front panel protrudes from the cabinet about an inch.

e. Grasp the front panel at the edges, and slide the chassis out of the cabinet.

4.1.3 Chassis Removal From Rack Mount

a. Disconnect the power plug and all connections to the rear panel jacks.

b. Remove the two inner screws located on the top bracket immediately behind the mounting panel.

c. Remove the five screws that secure the chassis to the shelf of the rack mount.

d. Push the receiver chassis forward until the front panel protrudes about one inch beyond the style frame.

e. Grasp the front panel at the edges, and slide the chassis out of the rack mount.

4.2 RECEIVER SIGNAL TRACING

Table 4-1 lists significant test points and normal signal levels. All rf and if. measurements up to V8-1 are made on USB as follows: A signal generator with calibrated output attenuator is connected at the listed test point. A vacuum-tube voltmeter is connected to the agc bus. Signal generator output is increased until the read-

ing on the vtvm just starts to increase (agc threshold). The level indicated on the output attenuator at this point is the signal level listed in the table. The signal generator is tuned to the frequencies listed in TEST POINT FREQUENCY column. Signal voltage at V7-1 and all following are measured with agc threshold as reference level. Local audio signal levels are measured with 1-watt audio output as reference. Line audio signal levels are measured with 10 milliwatts into a 600-ohm balanced line terminated with a 600-ohm balanced load. All values are nominal and may vary ± 20 percent.

4.3 VOLTAGE AND RESISTANCE MEASUREMENTS

4.3.1 Vacuum Tube Measurements

Table 4-2 lists voltage and resistance measurements for all tube sockets of the 51S-1 except those of vfo tube V15. Do not open the vfo oscillator can. Ac voltages shown in table 4-2 apply to 51S-1/1F/1B. These are dc voltages for 51S-1A/1AF. Measurements are made under the following conditions:

a. All measurements are made with a vtvm and with all tubes in sockets. All measurements are made with RF GAIN at maximum

Table 4-2. Voltage and Resistance Measurements

TUBE		PIN NUMBER								
		1	2	3	4	5	6	7	8	9
V1	Dc volt	1.2	0	0	0	145	75	0		
	Ac volt				6.3					
	Ohms	11 megohm	0	0	0	10K	10K	0		
V2	Dc volt	164	-7	158	0	0	158	0	4.3	0
	Ac volt				19.5	12.8			*1.5	
	Ohms	8500	470K	9500	0	0	8500	0	1000	270K
V3	Dc volt ^b	160	-6.2	105	0	0	165	0	4.3	0
	Ac volt				19.5	12.9			*1.5	
	Ohms	8500	100K	60K	0	0	8500	5	1000	35
V4	Dc volt	-1.2	0	165	0	0	165	4.3	-0.32	-1.5
	Ac volt				6.4	12.5		*0.7		
	Ohms	250K	35	8500	0	0	8500	1000	5000	250K
V5	Dc volt	-1.2	0			162	168	5.4		
	Ac volt				6.4					
	Ohms	500K	0	0	0	8500	8500	320		

Table 4-2. Voltage and Resistance Measurements (Cont)

TUBE		PIN NUMBER								
		1	2	3	4	5	6	7	8	9
V6	Dc volt	167	0	0.25	0	0	167	0.22	0.25	0
	Ac volt				25.5	25.5				19.5
	Ohms	8500	0	680	0	0	8500	**300K	680	0
V7	Dc volt	-1.2	0	0		155	70	0.13		
	Ac volt				6.4					
	Ohms	390K	0	0	0	8500	18K	20		
V8	Dc volt	-1.0	0	0	0	162	67	0		
	Ac volt			19.5	13					
	Ohms	900K	0	9	0	8500	19K	0		
V9	Dc volt	0	0			140	140	1.6		
	Ac volt			25.6	19.5					
	Ohms	100K	0	0	0	8500	8500	76		
V10	Dc volt ^c	140	-10	140			145		2.2	0
	Ac volt				13	19.5			*1.4	
	Ohms	8500	100K	8500	0	0	8500	5	220	0
V11	Dc volt		3.3	0	155	0	155	0	3.1	
	Ac volt	13								6.8
	Ohms	0	1000	5	11.2K	0	11.2K	360K	1000	0
V12	Dc volt	-12.3	1.6			155	146	-12.3		
	Ac volt			19.5	25.8					
	Ohms	240K	0	0	0	8000	12K	240K		
V13	Dc volt	-8.2	0			153	153	0		
	Ac volt			19.5	13					
	Ohms	475Ω	0	0	0	8500	8500	0		
V14	Dc volt	106	0	0.96			85			
	Ac volt				6.8	6.8				
	Ohms	100K	a	2200	0	0	460K	a	7000	0
V15	Dc volt Ac volt Ohms	VFO TUBE -- MAKE NO ATTEMPT TO MEASURE -- THIS WOULD REQUIRE OPENING VFO CAN								
V16	Dc volt	135	-72	72			118	0	2.5	0
	Ac volt				6.8	13.2				*1.4
	Ohms	8500	1 megohm	100K	0	0	115K	0	270	0
V17	Dc volt	-2.3	0			72	50	0		
	Ac volt			12.0	6.2	3.0				
	Ohms	1 megohm	0	0	0	70K	150K	0		

* Oscillator injection voltage measured with vtm and rf probe.
May vary from band to band.
** With Q-multiplier turned off.

^a Varies with AF GAIN setting.
^b 2 to 6 MHz only.
^c 0.2- and 1-M Hz bands only.

(fully clockwise) setting. All voltage measurements are made with power applied and OFF-STBY-ON-CAL in ON position except for measurements of calibration oscillator V16B. Voltage measurements of V17, bfo, are made with EMISSION switch in USB, LSB, or CW position.

b. Resistances of less than 0.9 ohm are listed as zero. All resistance measurements are made with power plug P10 removed from J10, and EMISSION switch in USB position.

c. All measurements are made from tube socket pin to ground.

d. All measurements are nominal and may vary $\pm 10\%$.

4.3.2 Transistor Measurements

Make dc voltage measurements for transistor Q1 with a vtvm. Apply primary power to the receiver and set OFF-STBY-ON-CAL switch to ON. Operating voltages for Q1 should be as follows:

- a. Emitter to ground, +1.95 volts dc.
- b. Base to ground, +2.05 volts dc.
- c. Collector to ground, +16.5 volts dc.

All measurements are nominal and may vary by ± 10 percent.

4.4 ALIGNMENT

Refer to figures 4-1 and 4-2 for adjustment points. For alignment of T9, T11, T12, T13, T1, T2, T3, T14, T15, T7, use Walsco #2543 or General Cement #8282 alignment tool.

4.4.1 100-kHz Calibrator Adjustment

- a. Tune in Radio Station WWV or WWVH on a convenient frequency, 2.5, 5, 10, 15, 20, or 25 MHz.
- b. Move the EMISSION switch to AM position.

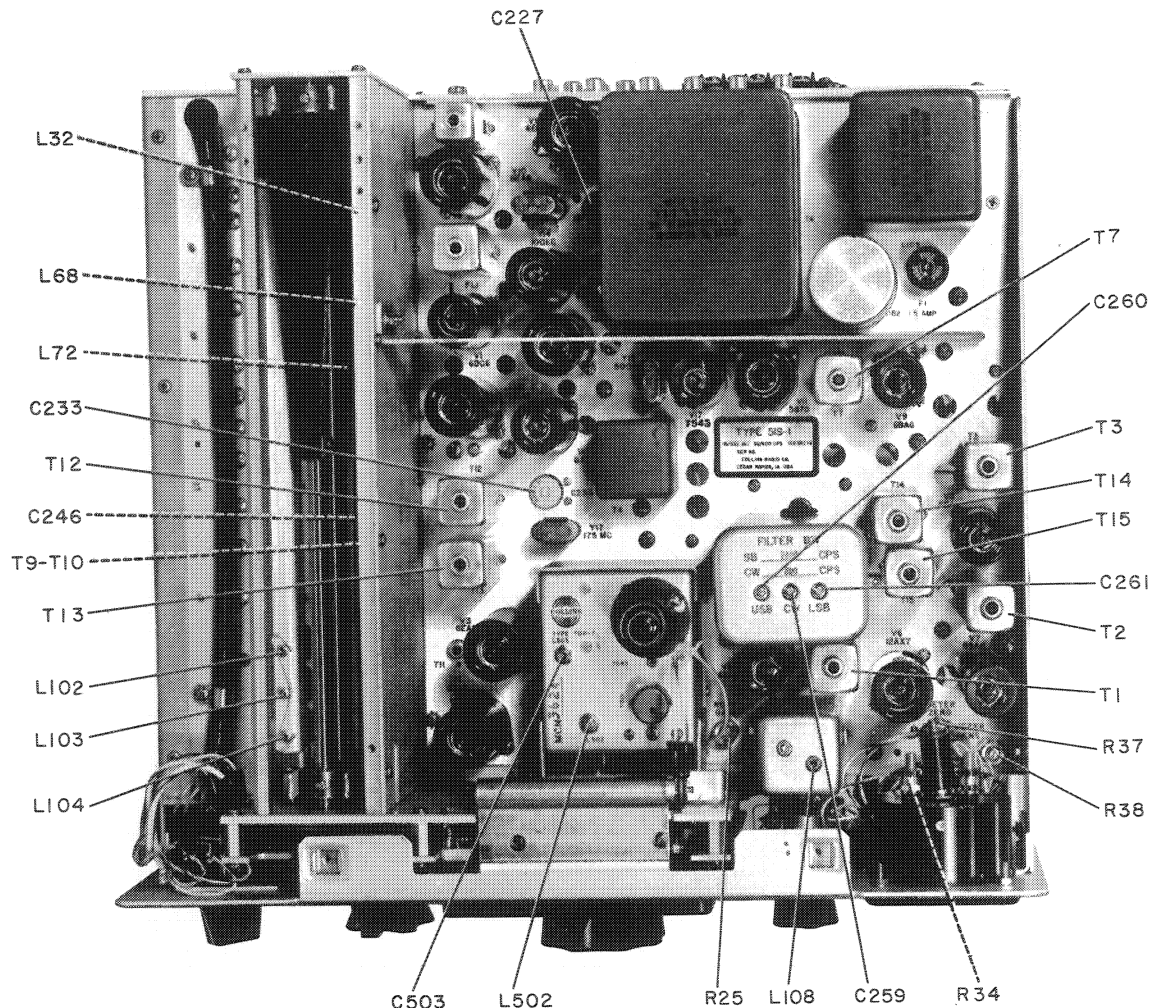

Figure 4-1. Top Chassis, Alignment and Adjustment Locations

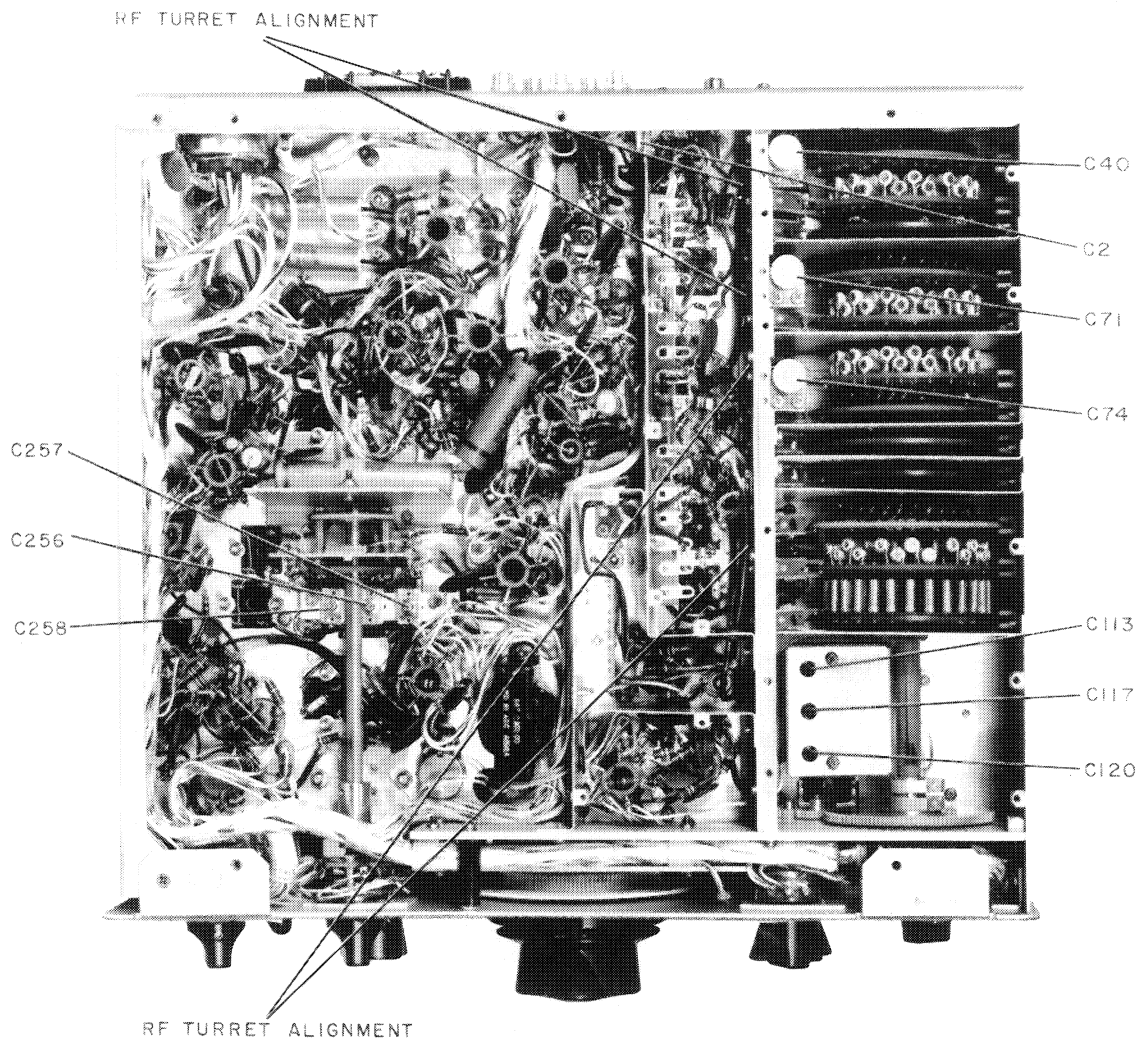

Figure 4-2. Bottom Chassis, Alignment and Adjustment Locations

c. Move the OFF-STBY-ON-CAL switch to CAL position.

d. Adjust C227, CAL ZERO, capacitor near the rear of the chassis to zero beat.

Note

Be careful not to zero beat one of the tone sidebands. Wait for the tone modulation of WWV or WWVH to go off before zeroing the calibrator.

4.4.2 RF Meter Zeroing

a. Set RF GAIN control, located on the front panel, to maximum (fully clockwise).

b. Move the meter switch to RF position.

c. Tune the 51S-1 to a clear, noise-free frequency and adjust R37, METER ZERO, to obtain an indication of 0 on the rf meter.

4.4.3 IF Alignment

- a. Connect a signal generator to the standoff side of R20 (the 33-ohm resistor that connects to pin 2 of V4).
- b. Set the 51S-1 EMISSION switch to LSB.
- c. Tune the signal generator around 500 kHz to zero beat in the 51S-1. Make sure that the 51S-1 vfo is tuned to a frequency which does not produce spurious signals in the output of the 51S-1.

Note

If receiver is equipped with optional 6-kHz mechanical filter in place of 5-kHz AM/IF transformer, skip the adjustment of T14 and T15 in step d, and skip steps f and g entirely.

- d. Set the EMISSION SWITCH TO AM. Peak transformers T1, T2, T7, T14, and T15 for maximum indication on the 51S-1 rf meter, adjusting the signal generator output for a consistent 20-db reading (as monitored on the 51S-1 rf meter).
- e. Turn on the signal generator modulation, and peak T3 for maximum audio output. Turn off modulation.
- f. Place swamping tools, composed of a 0.01-uf capacitor in series with a 1000-ohm resistor, across terminals 1 and 2 of transformers T14 and T15 (see figure 4-3 for terminal identification). Tune the top slugs of T14 and T15 for maximum reading on the

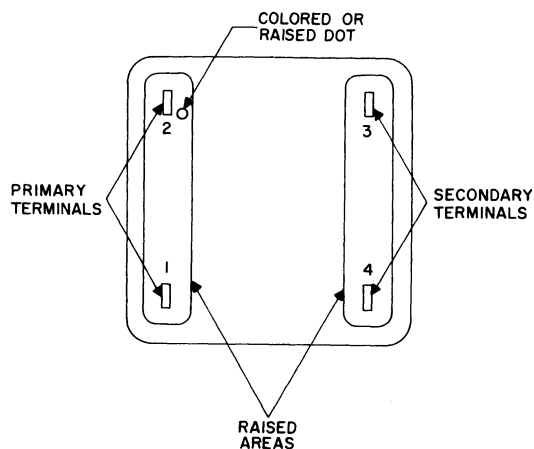

Figure 4-3. RF and IF Transformer Terminal Identification

51S-1 rf meter, again varying the signal generator output level for a consistent 20-db reading.

- g. Move the swamping tools to terminals 3 and 4 of transformers T14 and T15. Tune the bottom slugs of T14 and T15 for maximum reading on the 51S-1 rf meter, again varying the signal generator output level for a consistent 20-db reading. Remove the swamping tools.

- h. Set the 51S-1 EMISSION switch to USB and adjust the signal generator frequency to 502.500 kHz. A note of 2500 Hz should be heard at the 51S-1 output.

- i. Connect a swamping tool, identical to that used above, across terminals 1 and 2 (primary) of T1.

Note

Keep the signal generator output level below that required for agc threshold during T1 and T2 tune up.

- j. Peak the top slug of T1 (secondary) for maximum audio output. Move swamping tool to terminals 1 and 2 (primary) of T2 and repeat tuning procedure. Remove swamping tool.

- k. Set 51S-1 EMISSION switch to LSB and adjust the signal generator frequency to 497.500 kHz. A note of 2500 Hz should be heard at the 51S-1 output.

- l. Connect a swamping tool, identical to that used above, across terminals 3 and 4 of transformer T1. Peak the bottom slug of T1 for maximum audio output.

- m. Move swamping tool to terminals 3 and 4 of T2 and repeat the tuning procedure (step l). Remove swamping tool.

- n. Tune signal generator for a 1500-Hz beat note. Adjust trimmers C258 and C261 for maximum meter indication.

- o. Repeat the above step (step n) with the 51S-1 EMISSION switch in the USB position,

except adjust trimmers C257 and C260 instead of C258 and C261.

p. Set the 51S-1 EMISSION switch to CW and tune signal generator for a peak in rf meter reading. Adjust C256 and C259 for maximum 51S-1 rf meter indication.

4.4.4 3- to 2-MHz Variable IF Alignment

Note

When adjusting C113, an insulated or non-metallic screwdriver should be used to prevent the shorting to ground of the +150 volts present on the capacitor adjustment shaft.

- a. Set the MEGACYCLES control of the 51S-1 to 4 MHz and the EMISSION switch to AM.
- b. Connect a signal generator to pin 9 of V3.
- c. Tune the 51S-1 to 4.9 MHz.
- d. Tune the signal generator to 2.1 MHz, the 51S-1 variable if. frequency.
- e. Set C113, C117, and C120 to half capacity. See figure 4-4.
- f. Adjust L102, L103, and L104 for an indication of maximum on the rf meter. The meter switch should be in the RF position during this operation. Keep the signal generator output level adjusted to obtain an indication of 20 db.
- g. Tune the 51S-1 to 4.1 MHz and the signal generator to 2.9 MHz.
- h. Adjust C113, C117, and C120 for an indication of maximum on the rf meter of the 51S-1. Maintain an indication of 20 db on the rf meter by adjusting the signal generator output level.
- i. Repeat steps c, d, f, g, and h until no increase in rf meter reading can be obtained at either the 4.1- or 4.9-MHz setting.

4.4.5 14.5- to 15.5-MHz Bandpass Alignment

- a. Connect a signal generator to pin 9 of V2.
- b. Set the frequency of the signal generator to exactly 15 MHz.
- c. Tune in the signal on the 51S-1 by setting the tuning dial to 4.5 MHz.

d. Connect a swamping tool, consisting of a 0.01-uf capacitor in series with a 1000-ohm resistor, across each of the primary windings of T12 and T13.

e. Adjust the top slugs, which are associated with the secondary windings, of T12 and T13 for an indication of maximum on the rf meter of the 51S-1. Keep the signal generator output level adjusted for an indication of 20 db on the rf meter.

f. Remove the swamping tools from the primary windings, and place one across each of the secondary windings of T12 and T13.

g. Adjust the bottom slugs, which are associated with the primary windings, of T12 and T13 for an indication of maximum on the rf meter of the 51S-1. Keep the signal generator output level adjusted for an indication of 20 db on the rf meter.

4.4.6 RF Alignment

- a. Remove the turret shield on the bottom of the 51S-1.
- b. Turn the MEGACYCLES control to 29- to 30-MHz range, and tune the 51S-1 to 29.000 MHz. Move the EMISSION switch to AM position.
- c. Set the main tuning slugs, L32, L68, and L72, to 0.794 m (5/16 inch) less than full insertion into the coils as measured from bottom of coil forms.
- d. Set the main trimmer capacitors, C40, C71, and C74, to 1/2 capacity. See figures 4-1 and 4-4.
- e. Connect a signal generator to ANT, J1, on the rear of the 51S-1. Connect a vtvm to the 600 Ω UNBAL jack, J11, on rear apron.
- f. With the signal generator modulation turned on, tune the signal generator until a 29-MHz signal is heard on the 51S-1.

Note

Throughout rf alignment, keep the output level of the signal generator adjusted to the minimum level that will produce a discernible audio signal at the output of the 51S-1; this level must be below agc threshold as indicated by zero reading on rf meter.

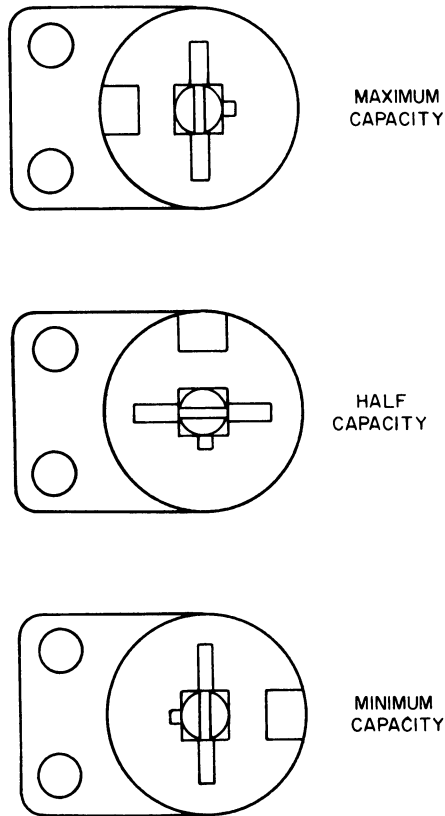

Figure 4-4. Trimmer Capacitor Settings

g. Insert the tuning tool through the slots in the turret side shield, and tune the slugs of the appropriate turret-mounted coils for maximum 51S-1 audio output.

h. Tune the 51S-1 and the signal generator to 29.9 MHz, and tune the main rf trimmer capacitors, C40, C71, and C74, for maximum 51S-1 audio output on vtvm.

i. Tune the 51S-1 and the signal generator to 29 MHz on the 29- to 30-MHz band, and repeat step g above.

j. Move the MEGACYCLES control of the 51S-1 to the 2.0- to 3.0-MHz band, and tune to 2.0 MHz.

k. Tune the signal generator so as to receive a 2.0-MHz signal on the 51S-1.

l. Place swamping tool across first rf tuned circuit to ground. Adjust 2.0-MHz turret coils L39 and L74 for maximum audio output from the 51S-1.

m. Remove swamping tool and place across second rf tuned circuit to ground. Adjust L2 for maximum audio output from the 51S-1.

n. Tune the 51S-1 and signal generator to 2.9 MHz and adjust slug in L32 for maximum output from the 51S-1.

o. Remove swamping tool and place across first tuned circuit to ground. Adjust slugs in L68 and L72 for maximum output on the 51S-1.

p. Recheck 2.0 MHz and touch up alignment if necessary. The swamping tool must be used on the opposite front end rf stage from the one that is being tuned.

q. All the other bands are aligned by peaking the appropriate turret coil slugs at the low frequency end of the band. The 3.0-, 4.0-, and 5.0-MHz coils must be tuned using the swamping tool. The swamping tool is not needed on the 6- to 29-MHz bands.

r. Repeat for all bands up to and including 29 MHz.

4.4.7 Megahertz Oscillator Alignment

a. Connect the rf probe of a vtvm to pin 8 of V2, and ground the vtvm to the chassis of the 51S-1.

b. Set the MEGACYCLES control of the 51S-1 to the 6- to 7-MHz band.

c. Tune the slug of T9 for maximum rf voltage as indicated on the vtvm. The slug of T9 is the slug farther from the chassis in the T9-T10 assembly.

d. Set the MEGACYCLES control of the 51S-1 to the 14- to 15-MHz band.

- e. Tune the slug of T10 for maximum rf voltage as indicated on the vtvm. The slug of T10 is the slug closer to the chassis in the T9-T10 assembly.
- f. Set the MEGACYCLES control of the 51S-1 to the 29- to 30-MHz band.
- g. Tune trimmer C246 for maximum rf voltage as indicated on the vtvm.
- h. Repeat steps b through g above.

4.4.8 17.5-MHz Oscillator Alignment

- a. Connect a vtvm with rf probe to pin 8 of V3.
- b. Set the MEGACYCLES control of the 51S-1 to the 4.0- to 5.0-MHz band.
- c. Adjust T11 for 1.5 volts indicated on the vtvm.
- d. Loosely couple a carefully calibrated receiver to the shield of V3.
- e. Tune the calibrated receiver to 17.5 MHz, and turn on the 100-kHz calibration oscillator of the calibrated receiver.
- f. Adjust C233 of the 51S-1 for zero beat as indicated on the calibrated receiver.

4.4.9 LF Oscillator Alignment

- a. Set the MEGACYCLES selector on the 51S-1 to the 1.0- to 2.0-MHz band.
- b. Connect a vtvm probe to pin 8 of V10.
- c. Tune the slug of T16 for maximum rf voltage.
- d. Couple a pickup loop around V10 and connect to a calibrated receiver.
- e. Tune the calibrated receiver to 28.0 MHz and turn on the calibration oscillator of the calibrated receiver.

- f. Adjust C2 of the 51S-1 for a zero beat in the calibrated receiver.

4.4.10 Megahertz Injection Frequency Adjustment

Note

Be sure the 51S-1 vfo is aligned properly before attempting to adjust the megahertz injection frequency. See paragraph 4.4.13 for vfo alignment.

- a. Set the MEGACYCLES control of the 51S-1 to the 2.0- to 3.0-MHz band.
- b. Couple a pickup loop around V15. Connect the pickup loop leads to a carefully calibrated receiver.
- c. Tune the calibrated receiver to 3.5 MHz. Switch on the 100-kHz crystal calibrator of the calibrated receiver. With the tuning knob on the front of the 51S-1, tune for zero beat between the vfo of the 51S-1 and the crystal calibrator of the calibrated receiver. (The 51S-1 dial will be very near the low end of the band.)
- d. Set the hairline of the 51S-1 to read zero on the kilohertz scale.
- e. Turn off the calibrated receiver.
- f. Move the OFF-STBY-ON-CAL switch of the 51S-1 to CAL position.
- g. Set the EMISSION switch of the 51S-1 to USB position.
- h. Insert the tuning tool through the slot in the turret side shield, and tune the appropriate turret-mounted, trimmer capacitor for zero beat as heard on the 51S-1.
- i. Move the MEGACYCLES switch to the next higher band.

Note

Be careful not to disturb the tuning knob which was set in steps b, c, and d above.

j. Repeat steps h and i above until all bands above 2.0 MHz are aligned.

4.4.11 Receiver Gain Adjustment

- a. Connect a signal generator to J1, ANT, on the rear of the 51S-1 as shown in figure 4.5.
- b. Tune the signal generator and 51S-1 to 14.5 MHz.
- c. Set the EMISSION switch on the 51S-1 to LSB position.
- d. Set the RF GAIN control of the 51S-1 fully clockwise.
- e. Set the output level of the signal generator to 15 microvolts (1.5 microvolts at the junction of resistors R1 and R2 of test setup). Adjust receiver tuning for a beat note of approximately 1000 Hz.
- f. Connect a dc vtvm to the age line of the 51S-1.
- g. Adjust R25, RCVR GAIN, to the setting where the voltmeter indication starts to in-

crease from a steady reading. This is the age threshold.

h. Repeat paragraph 4.4.2.

4.4.12 RF Meter Calibration

- a. Perform the alignment procedure of paragraph 4.4.11.
- b. Tune the signal generator and 51S-1 to 14.5 MHz. Set signal generator output to 1000 microvolts (100 microvolts at the junction of R1 and R2 of test setup).
- c. Set the meter switch of the 51S-1 in the RF position.
- d. Adjust R38, METER SENS, to obtain 40 db indicated on the rf meter of the 51S-1.

4.4.13 Q-Multiplier Alignment

- a. Tune the OFF-STBY-ON-CAL switch to CAL position.
- b. Set the EMISSION switch to USB position.
- c. Tune to zero beat with the calibrator signal at 6.5 MHz.

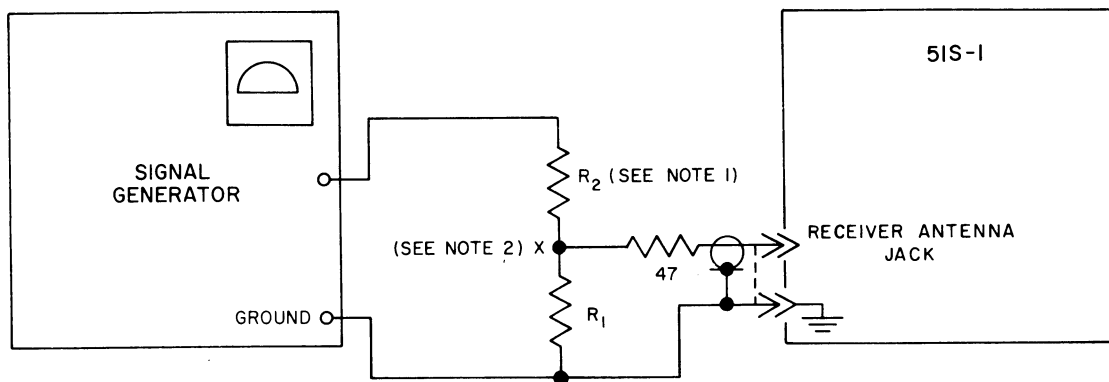

NOTES:

1. R_1 MUST BE 5 OHMS OR LESS; R_2 MUST BE 9 TIMES R_1 . THIS FORMS A 10:1 VOLTAGE DIVIDER (20DB PAD). $R_1 + R_2$ MUST EQUAL PROPER TERMINATION FOR SIGNAL GENERATOR USED. EXAMPLE: FOR HP606A, $R_1 + R_2 = 50$ OHMS.
2. WITH THIS TERMINATION (20DB PAD), SIGNAL GENERATOR OUTPUT READS 10 TIMES ACTUAL OUTPUT AT "X".

C712-25-3

Figure 4-5. Receiver Gain Adjustment Test Setup

- d. Set the EMISSION switch to AM position.
- e. Turn the REJECTION TUNING on the front of the 51S-1 to the center calibration mark.
- f. Set the meter switch to RF position.
- g. Adjust L108 and R34 to obtain the lowest reading on the rf meter.

4.4.14 VFO Alignment

Vfo aging may cause a tuning dial calibration error of the same amount in the same direction for both 0 and 1000. To adjust for this condition, proceed as follows:

- a. Set the hairline to zero with the ZERO SET knob.
- b. Turn the EMISSION switch to LSB.
- c. Turn the OFF-ON-STBY-CAL switch to CAL.
- d. Set the receiver dial frequency at 7.200 MHz.
- e. Locate the vfo shaft collar (just forward of L502). Loosen the pair of setscrews nearest the gear plate on the vfo shaft collar.
- f. Align the 0 on the kHz dial with the hairline and lock the tuning control.
- g. Manually twist the vfo shaft and collar until a zero beat is heard.
- h. Tighten the setscrews. If the setscrews are no longer accessible, mark the collar and the tuning control shaft and move both together until each setscrew is accessible.
- i. Check calibration at 0 and 1000.

If the tuning dial does not calibrate at 0 and 1000 ± 0.750 kHz without resetting the hairline, the error usually can be compensated with trimmer inductor L502. Proceed as follows:

- a. Make sure the 51S-1 calibration oscillator has been aligned to Station WWV or WWVH.

Tune the calibrate signal to zero beat at 1000 on the dial.

- b. Set the hairline to zero with the ZERO SET knob.
- c. Tune the 51S-1 to zero beat at the low end of the band (near 0 on the dial).
- d. Note the dial error in kilohertz.
- e. Multiply the dial error frequency noted in step d above by 1.5. Add the dial error to 1.5 times the dial error, and move the dial this compensating amount (passing through zero). For example, if the dial reading noted in step d is 1.0 kHz, 1.0 kHz plus 1.5 kHz equals 2.5 kHz. The dial reading 2.5 kHz lower is 98.5. Conversely, if the step d reading is 99, the compensation point is 2.5 kHz higher, or 001.5.
- f. Leave the dial set as above, and adjust inductor L502 to zero beat with the calibration signal.
- g. Repeat steps a through f until no error is present at end points.

4.5 MEGACYCLES DRIVE CHAIN REPLACEMENT

Refer to figures 4-6 and 6-6. Figure 4-6 shows the MEGACYCLES dial drive chain properly strung over MEGACYCLES band-switch drive sprocket, idlers, and counter dial drive sprocket. Figure 6-6 shows an exploded view of the complete mechanical band-switching and tuning mechanism.

- a. Remove 51S-1 from cabinet. Turn 51S-1 on its side, and remove bottom shield plate from turret. Using a flashlight, locate the turret wafer printed circuit pad having a single round nib. Turn the MEGACYCLES control until this single-nibbed pad of each wafer is connected to the fixed turret contacts. This places the receiver in the 2.0- to 3.0-MHz position.
- b. Remove the large tuning knob, the MEGACYCLES knob, and the ZERO SET knob from

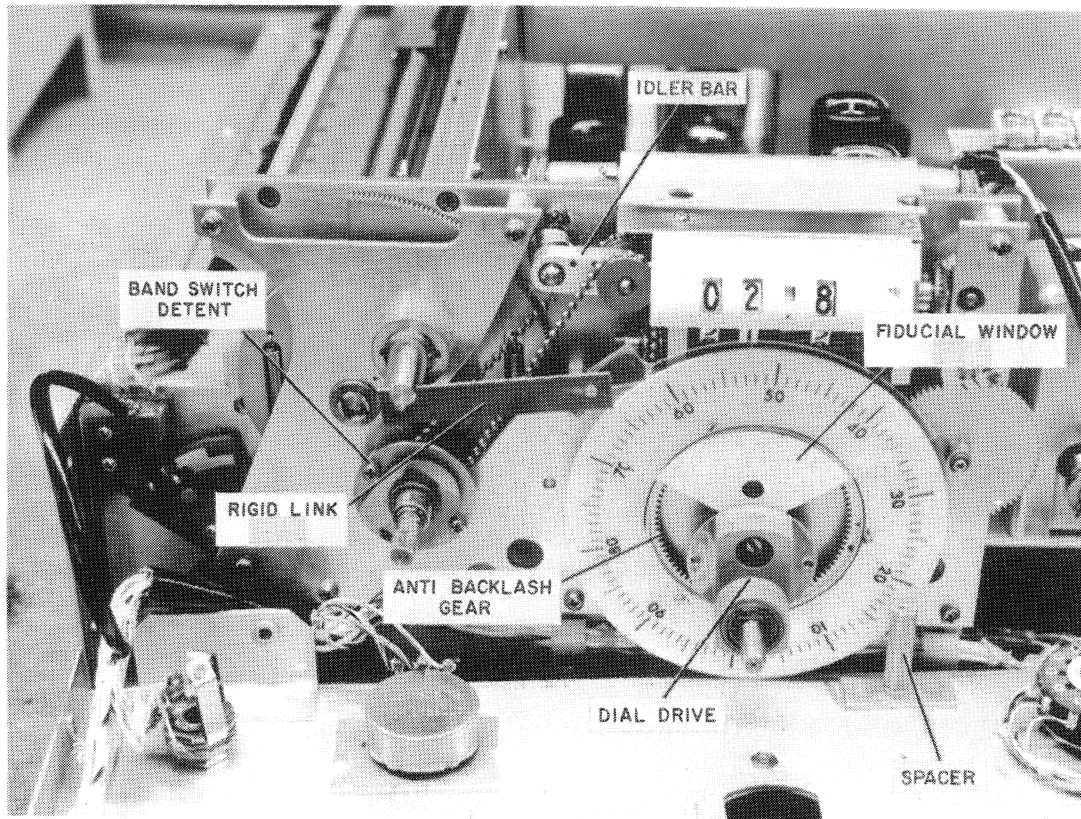

Figure 4-6. Band Indicator Bead Chain Stringing

their shafts. Remove the two small screws on either side of the tuning shaft. Loosen the coupling on the EMISSION switch shaft behind the detent plate and the first wafer. Remove the screw which secures the front gear plate to the panel, leaving the spacer fastened to the panel as shown in figure 4-6. At the front edge of each chassis side apron, remove the two screws which secure the front panel brackets to the side aprons. Remove the screw that secures the cable protecting rail to the front panel bottom bracket, and swing the rail aside. Move the panel out and down, taking care not to break any of the wiring between the back of the panel and the chassis. Remove zero set crank bar for easy access to the bead chain drive.

c. Remove the old bead chain. Remove the two screws holding the band-switch detent.

d. Thread the new chain over the MEGA-CYCLES drive sprocket and replace band-switch detent screws.

e. Press the idler bar downward, and thread the chain over the two idlers and under the counter drive sprocket. Release pressure on the idler bar. Idler bar should be horizontal after installation.

f. If the first two counter dials do not read 02., press the idler bar downward with one hand, and turn the counter dials manually with the other hand until the dials read 02. in the windows. Release pressure on the idler bar.

g. Replace panel, screws, knobs, and dust covers.

Note

If dial drive is removed, the antibacklash gear becomes unloaded. To preload, hold dial, and rotate front half of gear clockwise before meshing with drive pinion. Check to make sure EMISSION switch shaft grounding spring is under tension before tightening shaft coupler.

4.6 TURRET WAFER REPLACEMENT

If it is necessary to remove and replace turret wafers, refer to figure 6-6, and proceed as follows:

- a. Set MEGACYCLES control to 2 MHz. Remove the 51S-1 from its case, and stand the chassis on its side.
- b. Remove the turret bottom shield. Loosen the coupler clamp at the front end of the plastic turret shaft. This is the clamp farthest from the front panel. Do not loosen the clamp nearest the panel, or complete mechanical realignment will be necessary. This clamp is aligned at the factory.
- c. Grasp the shaft end near the coupler and push gently toward the rear. The shaft and its rear bearing should slide easily.

Caution

Take care that the shaft does not bind in any one of the turret wafers. Proceed carefully to move the shaft to the rear. Gently loosen any wafer which appears to be binding.

- d. Remove the defective wafer by withdrawing it straight out from the chassis.
- e. Grasp the replacement wafer edgewise with the thumb and forefinger placed across the wafer diameter, and insert it into the wafer guides. Be careful not to bind or twist the fixed turret contacts. Leave the wafer aligned so that its single-nibbed contact pad is in a row with those of the other turret wafers.

Caution

Do not touch the contact pads with the bare finger tips. Acids and oils normally present on the fingers will cause intermittent operation of the wafer pads and the turret contacts. Wear

clean rubber gloves, or handle as described in step e. If such an intermittent occurs, clean wafer with mild soap and warm water. Wipe dry with clean, lint-free cloth and replace.

f. When the wafer or wafers have been replaced and coarsely aligned as to turret position, insert the shaft from the rear, and start it through the rear wafer. As the shaft is brought to the wafer each time, twist the shaft enough to align it with the wafer hole and move it through. Use caution not to place undue stresses on the wafers or their guides.

g. As the shaft proceeds through the turret wafers and the coupler end approaches the coupler, the bearing on the rear end of the shaft will be entering the rear chassis bearing. At this time, grasp the shaft bearing with the fingers of the right hand, and keep the wafers free as necessary with the left hand. Guide the end of the shaft into the coupler with the left hand. Turn the shaft slightly back and forth as necessary with the right hand until the key in the coupler aligns with the keyway in the shaft. Push together until the shaft bearing enters the rear chassis bearing. While pressing the shaft bearing with the fingers of the right hand, rock the MEGACYCLES control with the left hand until the shaft bearing is flush with the rear chassis bearing. Tighten the clamp on the shaft coupler.

h. If two or more of the turret wafers are replaced at the same time, make sure all wafers are placed in the turret in proper order. Refer to figure 6-6. If new or repaired wafers are replaced in the turret, realign according to instructions of paragraph 4.4.6, 4.4.7, or 4.4.9.

Note

Wafers A2, A5, and A6 are identical in appearance as are A1, A4, and A7. However all turret wafers must be replaced in the exact position from which they were removed or complete realignment will be necessary. During removal, mark each wafer with pencil or tape, using care to keep all such foreign material off the circuit printing.

i. Replace the turret bottom shield, and replace the 51S-1 in its cabinet.

4.7 LAMP REPLACEMENT

Dial lamp DS1 is removed from the light reflector by grasping the lamp base at the terminal end and pulling straight out. Slight movement of the lamp holder

toward the rear of the unit may be required to clear the retaining screw.

DS2 (meter lamp) is a built-in part of M1. Remove by grasping the lamp holder and pulling straight out until it snaps free.

5.1 51S-1/1A/1F/1AF/1B RECEIVER

The 51S-1/1A/1F/1AF/1B Receiver receives USB, LSB, AM, and CW signals in the range of 0.2 to 30.0 MHz. Coverage is continuous in thirty 1-megahertz bands. The model 51S-1 is mounted in a perforated wrap-around cabinet and equipped with an ac power supply capable of 115- or 230-volt, single-phase, 50- to 400-Hz operation. The 51S-1A is similar, except that it is fitted with a 28-volt dc transistorized power supply. The rack-mounted ac version is model 51S-1F (figure 5-1). The rack-mounted dc version is model 51S-1AF. The 51S-1B (figure 5-2) is similar to the 51S-1, but it has a rear-mounted junction box that provides military-type connectors for power, control, audio, and antenna lines (refer to figure 7-4 for schematic diagram).

5.2 REQUIREMENTS FOR OPERATION

The 51S-1 and 51S-1F Receivers require 115- or 230-volt, single-phase, 50- to 400-Hz power at approximately 125 watts. The 51S-1B requires 115-volt, single-phase, 50- to 400-Hz power at approximately 125 watts. The 51S-1A/1AF Receiver requires 28 volts dc at 4.5 amperes. The 51S-1/1A Receiver may be mounted on table or bench for fixed station operation, or may be mounted with a mounting plate similar to the 351E-4 on shelf, bench, or table in moving aircraft, ground vehicle, or boat. 51S-1/1F/1A/1AF Receivers require a 4- or 600-ohm speaker or headphones for local audio monitoring, but monitoring devices of any impedance may be matched with 600-ohm line-to-monitor transformers at remote locations up to several



TP4-5385-017

Figure 5-1. 51S-1F in Rack Mount, Overall View



51S-1B With 350D-5 Base Shockmount, Overall View
 Figure 5-2

miles. Alternately, the 600-ohm line termination may be connected to telephone lines, or the 600-ohm local output may be used with a phone patch. The 51S-1B has the same local audio provisions as those described above, but the remote

audio line has a 150-ohm impedance (refer to figure 7-5). 51S-1 series receivers require an antenna with 50-ohm unbalanced feed; random length antennas may be used.

5.3 SPECIFICATIONS

Frequency range.....	0.2 to 30.0 megahertz in thirty 1-megahertz bands continuous coverage.
Modes.....	Upper sideband, lower sideband, AM or CW.
Power consumption.....	125 watts.
Type of service.....	Fixed station attended, or unattended, with provision for remote control of rf gain.
Rf input impedance	50 ohms, unbalanced.
500-kHz if. output at J9.....	50 mv minimum into 50-ohm load with 5-uv input signal.
Matching speaker impedance.....	4 or 600 ohms, unbalanced.

Balanced line output impedance.....	600 ohms balanced, center-tap ground reference or floating. (For 51S-1B, 150 ohms floating.)
Matching phone patch impedance (local).....	500 to 600 ohms.
Frequency stability.....	During temperature change from 0 to +50 °C, after 90 minutes warmup, audio output frequency will not vary more than ± 885 Hz for carrier frequencies from 2 to 7 MHz. From 7 MHz to 30 MHz, stability varies from 36 PPM ± 400 Hz at 7.00 MHz (652 Hz) to 27 PPM ± 400 Hz at 30 MHz (1210 Hz). For $\pm 10\%$ line voltage variation, frequency varies not more than ± 100 Hz.
Calibration accuracy.....	When zeroed to nearest 100 kHz calibration point, the frequency will be within ± 400 Hz.
Dial backlash.....	Not more than 150 Hz.
Audio-frequency response AM.....	100 to 2500 Hz ± 6 db (line channel). 200 to 2500 Hz ± 6 db (local channel).
SSB (high-frequency limit determined by filter bandwidth).....	350 to 3050 Hz ± 3.5 db (line channel). 350 to 3050 Hz ± 3.5 db (local channel).
Audio output distortion (SSB test signal 100-microvolt input, 1.0-watt local output, 1-mw (0 dbm) line output)	
Local.....	Not more than 10 percent.
Line.....	Not more than 3.0 percent.
Q-multiplier rejection notch depth.....	Not less than -40 dB.
Receiver sensitivity (nominal)	
AM.....	3.0 microvolts for not less than 10-db signal + noise/noise (2 to 30 MHz). 15.0 microvolts for not less than 10-db signal + noise/noise (0.5 to 2 MHz). 20.0 microvolts for not less than 10-db signal + noise/noise (0.2 to 0.5 MHz). With 55G-1 Preselector, 5.0 microvolts for not less than 10-db signal + noise/noise (0.2 to 2.0 MHz).

section 5
specifications

SSB and CW.....	0.6 microvolt for not less than 10-db carrier on carrier off (2 to 30 MHz).
	3.0 microvolts for not less than 10-db carrier on carrier off (0.5 to 2.0 MHz).
	4.0 microvolts for not less than 10-db carrier on carrier off (0.2 to 0.5 MHz).
	With 55G-1 Preselector, 1.0 microvolt for not less than 10-db carrier on carrier off (0.2 to 2.0 MHz).
Selectivity	
CW (at 6 db points).....	800 hertz bandwidth, nominal. (650 Hz minimum, 950 Hz maximum, 300-Hz maximum bandwidth optional).
SSB (at 3.5 db points).....	2.75 or 2.4 kHz bandwidth (3.1 kHz bandwidth optional).
AM (at 6 db points).....	5.0 kHz bandwidth minimum (6.0 kHz optional).
(at 60 db points).....	22.0 kilohertz bandwidth maximum.
Spurious responses (above 2 MHz)	
Internal spurious signals.....	Less than two microvolts equivalent signal.
Other spurious signals.....	Not less than 70 db down, except from 4.8 to 5.2 MHz, not less than 40 db down.
Image response.....	Not less than 50 db down from 2 to 25 MHz; not less than 40 db down from 25 to 30 MHz; referenced to midband.
Size.....	Cabinet version 196.85 mm (7.750 in) high by 374.65 mm (14.750 in) wide by 335.36 mm (13.203 in) deep. Rack-mounted version 221.44 mm (8.718 in) high by 482.60 mm (19.00 in) wide by 334.187 mm (13.187 in) deep (refer to figures 1-3 and 1-5).
Weight.....	28 pounds (12.70 kg), except 51S-1A/1AF.

5.4 TUBE AND SEMICONDUCTOR COMPLEMENT

Table 5-1. Tube and Semiconductor Complement

SYMBOL	FUNCTION	TYPE
V1	Rf amplifier	6DC 6
V2	First mixer and hf crystal oscillator	6EA 8
V3	Second mixer and 17.5 M Hz oscillator	6EA 8
V4	Third mixer and remote gain gate	6EA 8
V5, V7, and V8	If. amplifiers	6BA 6
V6	Q-multiplier	12AX 7
V9	Agc amplifier	6BA 6
V10	Lf mixer and lf crystal oscillator	6EA 8
V11	If. cathode follower and agc cathode follower	5670
V12	Second local af amplifier	6BF 5
V13	Second line af amplifier	6AK 6
V14	First line af amplifier and first local af amplifier	12AX 7
V15	Variable-frequency oscillator	7543
V16	Lf mixer and calibration oscillator	6EA 8
V17	Beat-frequency oscillator	7543
CR1 thru CR4	Product demodulator	1N 34A
CR5, CR18, CR19, and CR20	Meter rectifiers	1N 270
CR6 thru CR13	Power supply rectifier	1N 1695
CR14	Agc rectifier	1N 482A
CR15	AM detector	1N 34A
CR16	Agc stabilizer	1N 482A
CR17	M uting transient suppressor	1N 67A
CR401 thru CR403	Dc power supply rectifier	2N637B
Q1	SSB/CW af amplifier	2N388 or 2N222A
Q401 thru Q404	Dc power supply switching	2N 637B

5.5 AVAILABLE ACCESSORIES

Table 5-2. Available Accessories

ITEM	FUNCTION	COLLINS PART NUMBER
55G-1 Tuner	0.2- to 2.0-MHz If preselector, with speaker	522-3982-002
312B-3 Speaker	Cabinet speaker	522-1166-00
351E-4 Mounting Plate	Mount on table or bench	522-1482-00
28-volt dc power supply conversion kit	Converts 51S-1 to 51S-1A	554-8355-00
351R-1 Rack Mount	Rack mounts 51S-1/1A Receiver	522-2665-00
Cabinet assembly	Cabinet mounts 51S-1F/1AF Receiver	553-2449-00
312C-1 Speaker	Rack-mounted speaker	522-3526-00
312C-2 Speakers	Two speakers rack mounted	522-3527-00
312C-3 Speakers	Three speakers rack mounted	522-3528-00
Shockmounting kit	51S-1/1A Shockmount	757-2787-001
Headset HS-1 (600 ohms)	Insert in front panel	273-0021-010

5.6 DIFFERENCE DATA

Table 5-3 lists differences and part numbers of various models of the 51S-() communications receivers.

5.7 SCHEMATIC CHANGE INFORMATION

The period covered by this instruction book is 15 January 1974 to 22 September 1975.

Each equipment that had circuit changes made during the period of time covered by this instruction book has the changes identified on the applicable sheet of the schematic diagram and in the parts list. Circuit changes are flagged on the schematic with a change identifier (←) pointed at the component, group of components, or a circuit enclosed by a dashed line. The broken line indicates that the component or circuit has been changed, and the number inside the identifier indexes the specific change. If several components are affected by the change, there will be more than one identifier with the same index number.

The change identification numbers are listed on a schematic changes page that is inserted as sheet A of figure 7-1. The description gives the differences and the reasons for the changes.

The reason for identifying changes in this manner is that the manufacturer has scrambled serial numbers on his amateur products during the period covered by this instruction book.

None of the changes have been made because the equipment has failed to meet the equipment specifications and are not recommended changes for all units. Equipment changes have been made to improve performance or reliability of radios that are built using different fabrication processes. These changes will not necessarily improve the operation of your equipment. The change identification number also is used in the parts list section of this instruction book. However in the parts list the identification number is enclosed in slashes (for example, /2/) instead of the ← symbol.

Table 5-3. 51S-() Descriptions

MODEL	*DESCRIPTION	COLLINS PART NUMBER
51S-1	Receiver mounted in cabinet complete with tubes and mechanical filters. Operates on 115/230 Vac. Equipped with 2.4-kHz SSB mechanical filter and 800-Hz CW filter.	522-2245-00
	Same as above except equipped with 2.75-kHz SSB mechanical filter.	522-2245-030
51S-1A	Same as 51S-1 above except operates on 28 Vdc. Equipped with 2.4-kHz SSB mechanical filter.	522-2546-00
	Same as 51S-1A listed above except equipped with 2.75-kHz SSB mechanical filter.	522-2546-030
51S1-B	Same as the 51S-1 listed above except it has a rear-mounted junction box that provides military-type connectors for power, control, audio, and antenna lines.	522-3857-001
51S-1F	Same as 51S-1 except for standard 48.260-m (19-in) rack mounting. Equipped with 2.4-kHz SSB mechanical filter and 800-Hz CW filter.	522-2498-00
	Same as 51S-1F listed above except equipped with 2.75-kHz SSB mechanical filter.	522-2498-030
51S-1AF	Same as 51S-1A except for standard 48.260-m (19-in) rack mounting. Equipped with 2.4-kHz SSB mechanical filter and 800-Hz CW filter.	522-3156-00
	Same as 51S-1AF listed above except equipped with 2.75-kHz mechanical filter.	522-3156-030
<p>*All models described in this table are available with the following options:</p> <p>Option 1: 300-Hz CW filter.</p> <p>Option 2: 6-kHz mechanical filter in place of 5-kHz AM/if transformer.</p> <p>Option 3: 3.1-kHz mechanical filters vice either the 2.4- or 2.75-kHz mechanical filters.</p>		

section 6

parts list

6.1 INTRODUCTION

6.1.1 General

The purpose of this parts list is for identification, requisition, and issuance of parts.

Part numbers listed in this parts list meet critical equipment design specification requirements. Use only the part numbers specified in this parts list for replacement of parts.

6.1.2 Group Assembly Parts List

FIG - ITEM Column — Digits preceding the dash refer to the figure number. Digits following the dash are the item numbers assigned in sequence to correspond with the item numbers on the illustration.

PART NO Column — Listed are MIL standard, vendor, or Collins Radio Company part numbers. Collins part numbering system consists of 10 digits as follows: a 3-digit family number, a 4-digit serial number, and a 3-digit dash number.

INDENT Column — Items are coded 1, 2, 3, etc, to indicate the relationship to the next higher assembly.

DESCRIPTION Column — Lists the noun name, modifier, required descriptive information, federal manufacturer code, reference designation, attaching part (AP), reference to other figures, and effectivities.

Attaching parts are identified by (AP) following the part or parts they attach.

Effectivities are identified by the following methods: MCN (Manufacturer Control Number) 101 and up, CI (Configuration Identifier) 5-digit number, REV (Revision Identifier) dash (-) de-

notes original, letter A first change, letter B second change, etc. One of the above identifiers is listed on each chassis and/or replaceable assembly. Service Bulletins are identified by SB-1, SB-2, etc.

USABLE ON CODE Column — Part variations within the groups of equipment are indicated by a letter code (A, B, C, etc). The absence of the code indicates parts apply to all models.

UNITS PER ASSY Column — Quantities specified are per item number. The letters AR denote the selection of parts as required. The letters RF refer to an assembly completely assembled on a preceding figure and illustration.

6.1.3 Numerical Index

PART NUMBER Column — Part numbers are listed in alphanumeric sequence.

FIG - ITEM Column — Digits preceding the dash refer to the figure number. Digits following the dash are the item numbers.

TTL REQ Column — Listed is the total quantity of parts or assemblies covered in the group assembly parts list.

6.1.4 Reference Designation Index

REFERENCE DESIGNATION Column — Reference designations are listed in alphanumeric sequence.

FIG - ITEM Column — Digits preceding the dash refer to the figure number. Digits following the dash are the item numbers.

PART NUMBER Column — Part numbers listed are for items that have reference designations assigned.

HOW TO USE THIS PARTS LIST

1. FIND PAGE NO. IN LIST OF ILLUSTRATIONS

5. FIND PART NO. IN NUMERICAL INDEX

2. FIND PART AND ITS ITEM NO.

7. LOCATE PART ON ILLUSTRATION

The diagram illustrates the process of finding a part number from an illustration. It shows four main components:

- Reference Designation Index:** A table listing various part numbers and their corresponding reference designations.
- Numerical Index:** A table listing part numbers in numerical order, with columns for part number, quantity, and description.
- Group Assembly Parts List:** A detailed list of parts for a specific assembly, including part numbers, quantities, and descriptions.
- Illustration:** A technical drawing of a filter assembly with numbered callouts (1-11) pointing to various components.

Arrows indicate the flow of information: from the illustration to the Group Assembly Parts List (Step 2), from the Group Assembly Parts List to the Numerical Index (Step 3), from the Numerical Index to the Reference Designation Index (Step 4), and from the Reference Designation Index back to the illustration (Step 7).

HOW TO FIND THE PART NUMBER IF THE SECTION OR SYSTEM OF THE EQUIPMENT IN WHICH THE PART IS USED IS KNOWN:

HOW TO FIND THE ILLUSTRATION FOR A PART IF THE PART NUMBER IS KNOWN:

- (1) Refer to the List of Illustrations and find the page number for the Major Assembly or System in which the part is used.
- (2) Locate the part item number and/or reference designation on the illustration.
- (3) Find the item number on the Group Assembly Parts List page to determine complete description.
- (4) If only the reference designation is known, refer to the Reference Designation Index to find the part number.

- (5) Refer to the Numerical Index and find the part number.
- (6) Turn to the Group Assembly Parts List and find the first figure and item number indicated in the Numerical Index for that part. If this figure shows the part in a section or system of the equipment other than the one desired, refer to the other figure numbers listed in the Numerical Index.
- (7) On the illustration, find item number determined in step (6).

6.1.5 Manufacturer's Code, Name, and Address

CODE	MANUFACTURER'S NAME AND ADDRESS	CODE	MANUFACTURER'S NAME AND ADDRESS
A0473	Avery Label Co., Inc. Div. of Avery Adhesive Products, Inc. Peoria, IL 61600	07716	TRW Electronic Components IRC Fixed Resistors Burlington Div. 2850 Mt. Pleasant Burlington, IA 52601
A1334	Joyner Corp. Ocoess, MN	08257	NPC Electronics P.O. Box 1454 Canogo Park, CA 91304
00136	McCoy Electronics Co. Watts-Chestnut St. Mt. Holly Springs, PA 17065	08664	Bristol Div. of American Chain and Cable Co., Inc. Bristol Rd. Waterbury, CT 06720
00779	Amp, Inc. P.O. Box 3608 Harrisburg, PA 17105	08806	General Electric Co. Miniature Lamp Products Dept. Nela Park Cleveland, OH 44112
01139	General Electric Co. Silicone Products Business Dept Waterford, NY 12188	09250	Electro Assemblies, Inc. 4338 W. Montrose Ave. Chicago, IL 60641
01295	Texas Instrument, Inc. Components Group 13500 N. Central Expressway Dallas, TX 75222	09922	Burndy Corp. Richards Ave. Norwalk, CT 06852
02660	Bunker-Ramo Corp., The Amphenol Connector Div. 2801 S. 25th Ave. Broadview, IL 60153	12127	Permonite Mfg. Co. 910 Jackson Blvd. Chicago, IL 60607
03877	Transitron Electronic Corp. 168-186 Albion St. Wakefield, MA 01880	12204	Chrysler Corp. 341 Massachusetts Ave. Detroit, MI 48231
04713	Motorola, Inc. Semiconductor Products Div. 5005 E. McDowell Rd. Phoenix, AZ 85008	18986	Jetron, Inc. 4310 N. Kedzie Ave. Chicago, IL 60618
06214	National Bag Co., Inc. 133 W. Spring St. Naperville, IL 60540	21242	American Electronic Components Corp. 7516 Camargo Rd. Cincinnati, OH 45243
07263	Fairchild Semiconductor A Div. of Fairchild Camera and Instrument Corp. 464 Ellis St. Mountain View, CA 94042		

section 6
parts list

CODE	MANUFACTURER'S NAME AND ADDRESS	CODE	MANUFACTURER'S NAME AND ADDRESS
24457	General Electric Co. Wire and Cable Products Dept. 1285 Boston Ave. Bridgeport, CT 06602	70903	Belden, Corp 415 S. Kilpatrick Chicago, IL 60644
25088	Siemens America, Inc. 350-5 Ave. New York, NY 10001	71034	Bliley Electric Co. 2545 W. Grandview Blvd. Erie, PA 16512
27545	Hartford-Universal Co. 1022 Elm St. Rocky Hill, CT 06067	71400	Bussmann Mfg. Div. of McGraw-Edison Co. 2536 W. University St. St. Louis, MO 63107
28520	Heyman Mfg. Co. 147 N. Michigan Ave. Kenilworth, NJ 07033	71450	CTS Corp. 1142 W. Beardsley Ave. Elkhart, IN 46514
32712	Electro Vector, Inc. 6555 Covey Rd. Forestville, CA 95436	71590	Centralab Electronics Div. of Globe-Union, Inc. 5757 N. Green Bay Ave. Milwaukee, WI 53201
33173	General Electric Co. Tube Products Dept. 316 E. 9th St. Owensboro, KY 42301	71785	Cinch Mfg. Co. Div. of TRW Inc. 1501 Morse Ave. Elk Grove Village, IL 60007
38315	Honeywell, Inc. Precision Meter Div. Manchester, NH 03105	72136	Electro Motive Mfg. Co., Inc., The S. Park and John Streets Willimantic, CT 06226
40920	Miniature Bearing Div. MPB Corp. Optical Ave. Precision Park Keene, NH 03431	72765	Drake Mfg. Co. 4626 N. Olcott Ave. Harwood Heights, IL 60656
49671	RCA Corp. 30 Rockefeller Plaza New York, NY 10020	72982	Erie Technological Products, Inc. 644 W. 12th St. Erie, PA 16512
56289	Sprague Electric Co. North Adams, MA 01247	73386	Freed Transformer Co., Inc. 1736 Weirfield St. Brooklyn, NY 11227
62869	Veeder Root Inc. Counting Devices Div. Hartford, CT 06101	75382	Kulka Electric Corp. 633-643 S. Fulton Ave. Mt. Vernon, NY 10550
70892	Bead Chain Mfg. Co., The 110 Mountain Grove St. Bridgeport, CT 06605	75543	Lavelle Rubber Co. 424 N. Wood Chicago, IL 60622

CODE	MANUFACTURER'S NAME AND ADDRESS	CODE	MANUFACTURER'S NAME AND ADDRESS
76487	Millen, James, Mfg. Co., Inc. 150 Exchange St. Malden, MA 02148	83003	Varo, Inc. 800 W. Garland Ave. Garland, TX 75040
76854	Oak Mfg. Co. Switch Div. S. Main St. Crystal Lake, IL 60014	86684	RCA Corp. Electronic Components 415 S. 5th St. Harrison, NJ 07029
78189	Illinois Tool Works, Inc. Shakeproof Div. St. Charles Rd. Elgin, IL 60126	88407	Bulova Watch Co., Inc. Electronics Div. 61-20 Woodside Ave. Woodside, NY 11377
78488	Stackpole Carbon Co. St. Marys, PA 15857	91663	Armel Electronics, Inc. 1601 75th St. North Bergen, NJ 07047
78553	Tinnerman Products, Inc. 8700 Brookpark Rd. Cleveland, OH 44129	92054	Radio Cores, Inc. 5433 W. 95th St. Oak Lawn, IL 60453
81348	Federal Specifications	94148	TRW, Inc. Semiconductor Div. 14520 Aviation Blvd. Lawndale, CA 90260
81349	Military Specifications	95121	Quality Components, Inc. P.O. Box 113 St. Marys, PA 15857
81483	International Rectifier Corp. 9220 Sunset Blvd. Los Angeles, CA 90069	95265	National Coil Co. 2021 Pan American Douglas, AZ 85607
81815	Communication Coil Co. 2839 N. Narragansett Ave. Chicago, IL 60634	96906	Military Standards
81860	Barry Div. of Barry Wright Corp. 700 Pleasant Watertown, PA 02172	98291	Sealectro Corp. 225 Hoyt Mamaroneck, NY 10544
82142	Airco Speer Electronics Div. of Air Reduction Co., Inc. Grand Plaza 945 Grand Ave. Nogales, AZ 85621	99800	American Precision Industries, Inc. Delevan Div. 270 Quaker Rd. East Aurora, NY 14052
82389	Switchcraft, Inc. 5555 N. Elston Ave. Chicago, IL 60630		
82893	Vector Electronics Co. Glendale, CA 91200		

6.1.6 Usable on Codes

The following usable on codes have been assigned in this manual:

<u>USABLE ON CODES</u>	<u>UNIT PART NUMBER</u>	<u>FIG-ITEM</u>
A	522-2245-000	6-1-
B	522-2245-030	6-1-
C	522-2546-000	6-1-
D	522-2546-030	6-1-
E	522-2498-000	6-1-
F	522-2498-030	6-1-
G	522-3156-000	6-1-
H	522-3156-030	6-1-
I	522-3857-001	6-1-

6.1.7 Reference Designation Prefixes

The following prefixes have been assigned in this manual:

<u>PREFIX</u>	<u>UNIT PART NUMBER</u>	<u>FIG-ITEM</u>
A1	547-2680-004	6-8-
A2	547-2685-004	6-9-
A3	547-2682-004	6-10-
A4	547-2680-004	6-8-
A5	547-2685-004	6-9-
A6	547-2685-004	6-9-
A7	549-0630-004	6-11-
A8	547-2681-004	6-12-
A9	547-2691-004	6-13-
A10	547-2677-004	6-14-
A11	015-1200-000	6-7-36

6.1.8 Configuration Identifiers

The following CI's/REV LTR were used in compiling data for this manual:

<u>CI/ REV LTR</u>	<u>UNIT PART NUMBER</u>	<u>FIG-ITEM</u>
AF	522-2245-000	6-1-
AF	522-2245-030	6-1-
M	522-2546-000	6-1-
M	522-2546-030	6-1-
K	522-3156-000	6-1-
M	522-3856-030	6-1-
K	522-3857-001	6-1-
AH	522-2498-000	6-1-

<u>CI/ REV LTR</u>	<u>UNIT PART NUMBER</u>	<u>FIG-ITEM</u>
72114	547-2742-006	6-1-9
72114	767-6255-001	6-1-9
72083	548-8245-000	6-1-14
71463	767-6254-001	6-2-
CM	547-2791-001	6-3-
BG	549-0212-006	6-3-
BG	549-0212-000	6-3-
CM	547-2791-018	6-3-
CM	547-2791-000	6-3-
H	547-2693-000	6-4-
F	547-3930-000	6-5-
AU	547-2692-000	6-6-
AN	547-2694-005	6-7-
67453	547-2680-004	6-8-
F	547-2685-004	6-9-
F	547-2682-004	6-10-
67453	549-0630-004	6-11-
65013	547-2681-004	6-12-
65013	547-2691-004	6-13-
68083	547-2677-004	6-14-
73013	522-3970-001	6-15-
69323	767-6256-001	6-15-3

6.2 GROUP ASSEMBLY PARTS LIST

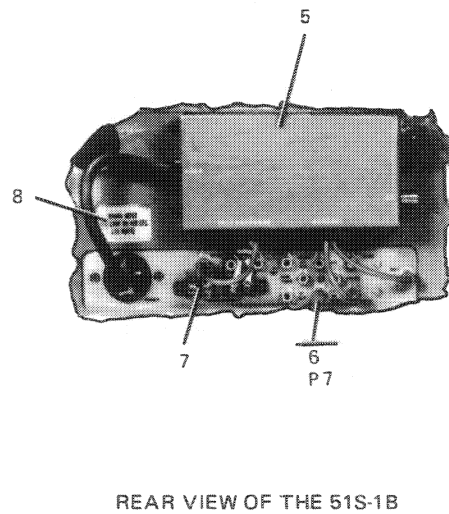
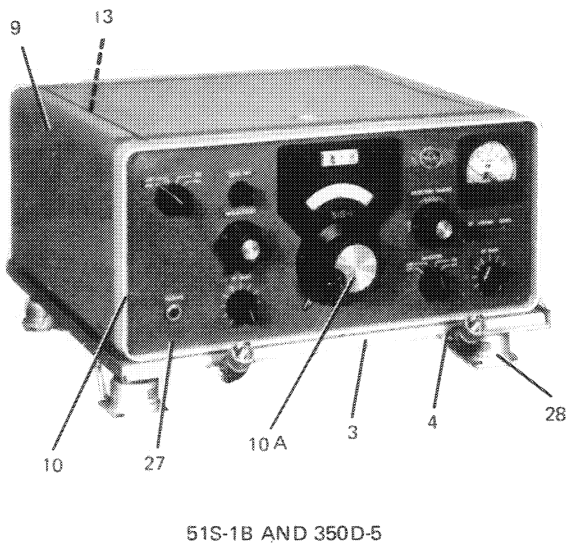
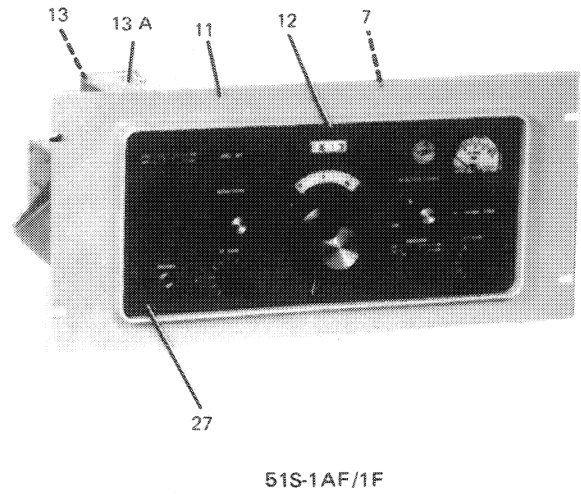
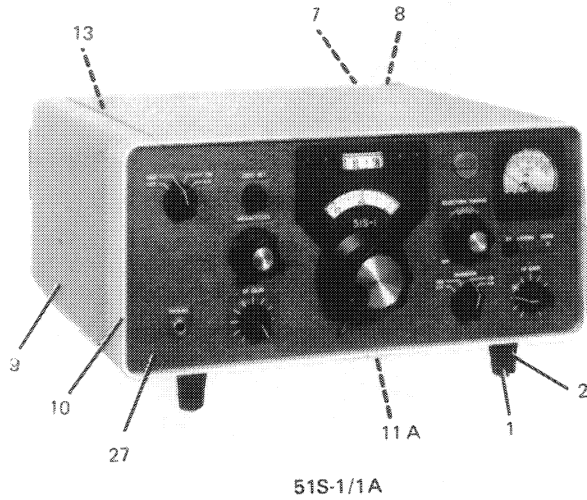

TP3-8057-027

51S-1() Receiver and 350D-5 Base Shockmount
Figure 6-1 (Sheet 1 of 2)

GROUP ASSEMBLY PARTS LIST

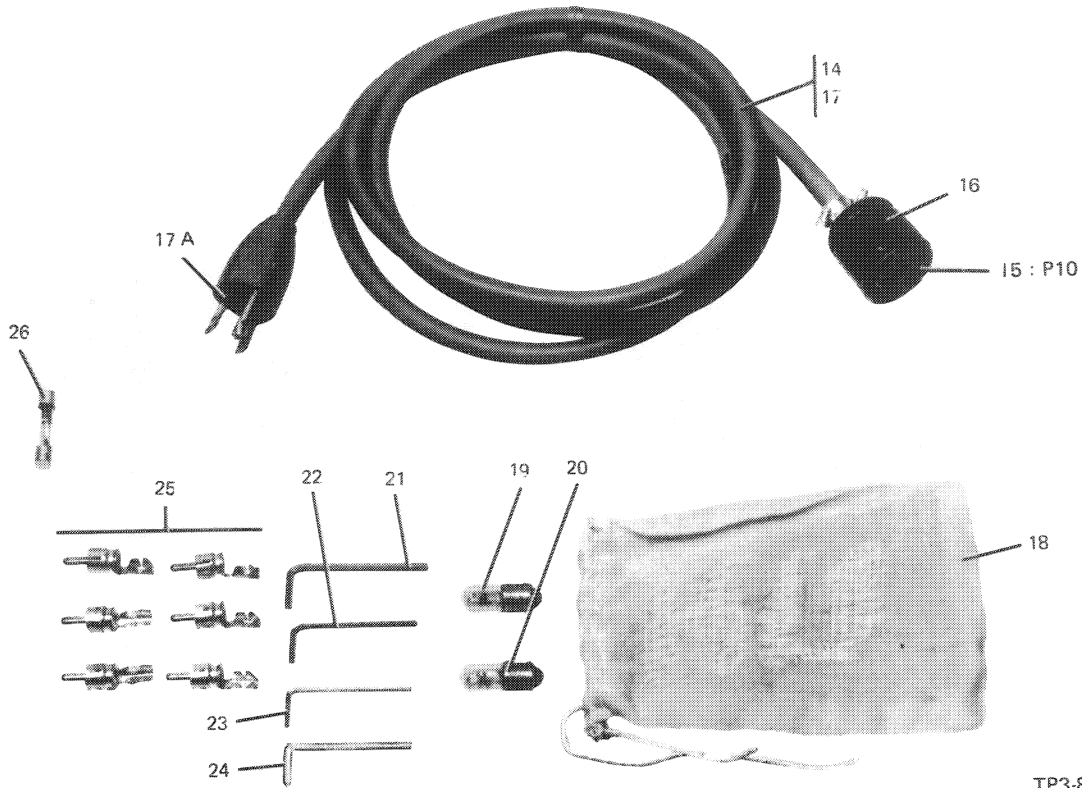

TP3-8057-027

51S-1() Receiver and 350D-5 Base Shockmount
Figure 6-1 (Sheet 2)

FIG - ITEM	PART NO	INDENT	DESCRIPTION	USABLE ON CODE	UNITS PER ASSY
6-1 -	522-2245-000	1	RECEIVER 51S-1	A	1
-	522-2245-030	1	RECEIVER 51S-1	B	1
-	522-2546-000	1	RECEIVER 51S-1A	C	1
-	522-2546-030	1	RECEIVER 51S-1A	D	1
-	522-2498-000	1	RECEIVER 51S-1F	E	1
-	522-2498-030	1	RECEIVER 51S-1F	F	1
-	522-3156-000	1	RECEIVER 51S-1AF	G	1
-	522-3156-030	1	RECEIVER 51S-1AF	H	1
-	522-3857-001	1	RECEIVER 51S-1B	I	1
1	747RRLACK	2	BUMPER,RRR (V75543) 200-5010-000	A,B,C,D	4
2	543-8101-002	2	FOOT	A,B,C,D	2
3	767-6252-001	2	PLATE,MOUNTING	I	1
4	554-4493-001	3	STRAP,RETAINING	I	2
5	767-6254-001	2	BOX ASSEMBLY, INTERCONNECTING (SEE FIG 6-2	I	1
6	544-3143-002	2	LOAD,DUMMY P7	I	1
7	548-1327-002	2	LEAD (EFF TO REV LTR AF)	A,B,G	1
7	761-5912-001	2	LEAD (EFF TO REV LTR M)	D	1
7	548-1327-002	2	LEAD (EFF TO REV LTR AH)	E,F	1
7	548-1327-002	2	LEAD (EFF TO REV LTR K)	G,H	1
7	761-5912-001	2	LEAD	I	1
8	280-3015-000	2	LABEL (VA0473) 280-3015-000 (EFF TO REV LTR AF)	A,B	1
8	280-3013-000	2	LABEL (VA0473) 280-3013-000 (EFF TO REV LTR AF)	A,B	1
8	280-3015-000	2	LABEL (VA0473) 280-3015-000 (EFF TO REV LTR M)	C,D	1
8	280-3013-000	2	LABEL (VA0473) 280-3013-000 (EFF TO REV LTR M)	C,D	1
8	280-3015-000	2	LABEL (VA0473) 280-3015-000 (EFF TO REV LTR AH)	E,F	1

GROUP ASSEMBLY PARTS LIST

FIG - ITEM	PART NO	INDENT	DESCRIPTION	USABLE ON CODE	UNITS PER ASSY
6-1	8	280-3013-000	2 LABEL (VA0473) 280-3013-000 (EFF REV LTR AH)	E,F	1
	8	280-3015-000	2 LABEL (VA0473) 280-3015-000 (EFF TO REV LTR K)	G,H	1
	8	280-3013-000	2 LABEL (VA0473) 280-3013-000 (EFF REV LTR K)	G,H	1
	8	280-3015-000	2 LABEL (VA0473) 280-3015-000 (EFF TO REV LTR J)	I	1
	8	280-3013-000	2 LABEL (VA0473) 280-3013-000 (EFF REV LTR J)	I	1
	9	547-2742-006	2 CABINET	A,B,C,D	1
	9	767-6255-001	2 CABINET	I	1
	10	609-0573-001	3 FRAME,STYLE	E,F,I	1
		543-8116-002	3 SCREW (AP)	E,F,I	2
		503-2604-001	3 WASHER,FLAT (AP)	E,F,I	2
	10A	553-5787-003	2 KNOB, SPINNER		1
	11	548-1322-005	2 PANEL	E,F,G	1
	11A	547-2652-003	2 COVER		1
	12	548-1323-004	2 FRAME,STYLE	G	1
	12	609-0573-001	2 FRAME,STYLE	E,F	1
	13	547-2796-002	2 TOOL,TUNING		1
	13A	547-2603-003	2 HOUSING, SLUG RACK (EFF REV LTR AF)	A,B	1
	13A	547-2603-003	2 HOUSING, SLUG RACK (EFF REV LTR M)	C,D	1
	13A	547-2603-003	2 HOUSING, SLUG RACK (EFF REV LTR AH)	E,F	1
	13A	547-2603-003	2 HOUSING, SLUG RACK (EFF REV LTR K)	G,H	1
	13A	547-2603-003	2 HOUSING, SLUG RACK (EFF REV LTR J)	I	1
	14	548-8245-000	2 CORD ASSEMBLY, ELECTRICAL	B,C,D,G	1
	14	547-2795-000	2 CORD ASSEMBLY, ELECTRICAL	A	1
	15	78S9M1001	3 CONNECTOR,RCPT, ELEC (V02660) 372-1953-000 P10	A,D,G	1
	16	3-24	3 SHIELD,ELEC CON (V02660) 372-1762-000 (REPLACE WITH 372-2270-010)	A,B,C,D G	1
	16	3-858	3 CLAMP,CABLE (V02660) 372-2270-010 (REPLACES 372-1762-000)	A,B,C,D G	1
	17	SI-53184	3 CABLE,PWR,ELEC (V24457) 424-0009-000	B,D,G	1
	17A	KH3491	3 CABLE ASSY,PWR (V70903) 426-1464-000 P25	A	
	18	024-C100-000	2 BAG,COTTON DUCK (V06214) 024-0100-000		1
	19	GE44	2 LIGHT RULR (V08806) 262-3220-000		1
	20	MS15571-2	2 LAMP,INCAND (V96906) 262-3240-000		1
	21	S096CADPL	2 KEY,SKT SCR (V08664) 024-0019-000		1
	22	S076-4	2 KEY,SKT SCR (V08664) 024-9730-000		1
	23	TYIICL1-062	2 KEY,SKT SCR (V81348) 024-2900-000		1
	24	S072CHEMRLK	2 KEY,SKT SCR (V08664) 024-0167-000		1
	25	3501MC	2 PLUG,TEL (V82389) 361-0062-000		6
	26	F02A250V6AS	2 FUSE,CRTG (V81349) 264-4100-000	E,D,G	1
	27	547-2791-000	2 RECEIVER SUBASSEMBLY (SEE FIG 6-3)	A,E	1
	27	547-2791-001	2 RECEIVER SUBASSEMBLY (SEE FIG 6-3)	B,F	1
	27	549-0212-000	2 RECEIVER SUBASSEMBLY (SEE FIG 6-3)	C,G	1
	27	549-0212-006	2 RECEIVER SUBASSEMBLY (SEE FIG 6-3)	D,H	1
	27	547-2791-000	2 RECEIVER SUBASSEMBLY (SEE FIG 6-3) (EFF REV LTR J)	I	1
	27	547-2791-018	2 RECEIVER SUBASSEMBLY (SEE FIG 6-3) (EFF TO REV LTR J)	I	1
	28	522-3970-001	1 SHOCKMOUNT,BASE 3500-5 (SEE FIG 6-15)	I	1

GROUP ASSEMBLY PARTS LIST

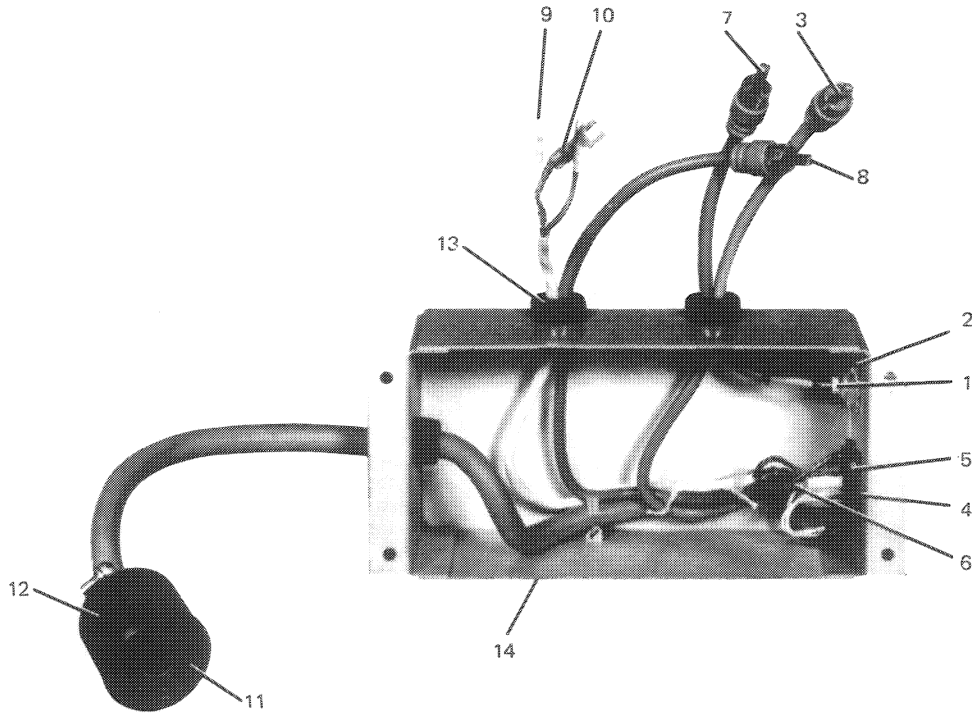

TP3-8058-017

Interconnecting Box Assembly
Figure 6-2

FIG - ITEM	PART NO	INDENT	DESCRIPTION	USABLE ON CODE	UNITS PER ASSY
6-2 -	767-6254-001	1	BOX ASSEMBLY, INTERCONNECTING (SEE FIG 6-1-5)		REF
1	M39C12-21-0001	2	CONNECTOR, RCPT, ELEC (V81349) 357-9670-000 J102		1
2	254C-20-03	2	TERMINAL, LUG (V78189) 304-0116-000		1
3	426-1809-000	2	CABLE ASSY (V12127) 426-1809-000 P1		1
4	MS3112E12-10P	2	CONNECTOR, RCPT, ELEC (V96906) 371-2156-000 J101		1
5	2104-C4-C1-2520N	2	TERMINAL, LUG (V78189) 304-0317-000		2
6	YE1620F29	2	ADAPTER, CABLE (V09922) 372-8015-000		2
7	426-1809-000	2	CABLE ASSY (V12127) 426-1809-000 P5		1
8	426-1811-000	2	CABLE ASSY (V12127) 426-1811-000 P4		1
9	321C35	2	TERMINAL, LUG (V00779) 304-0413-000		2
10	3408C	2	TERMINAL, LUG (V00779) 304-0414-000		1
11	78S9M1001	2	CONNECTOR, RCPT, ELEC (V02660) 372-1953-000 P10		1
12	3-24	2	SHIELD, ELEC CON (V02660) 372-1762-000 (REPLACE WITH 372-2270-010)		1
12	3-858	2	CLAMP, CABLE (V02660) 372-2270-010 (REPLACES 372-1762-000)		1
13	SR6P4	2	BUSHING, STRAIN (V28520) 150-0050-000		3
14	761-5916-001	2	CHASSIS		1

GROUP ASSEMBLY PARTS LIST

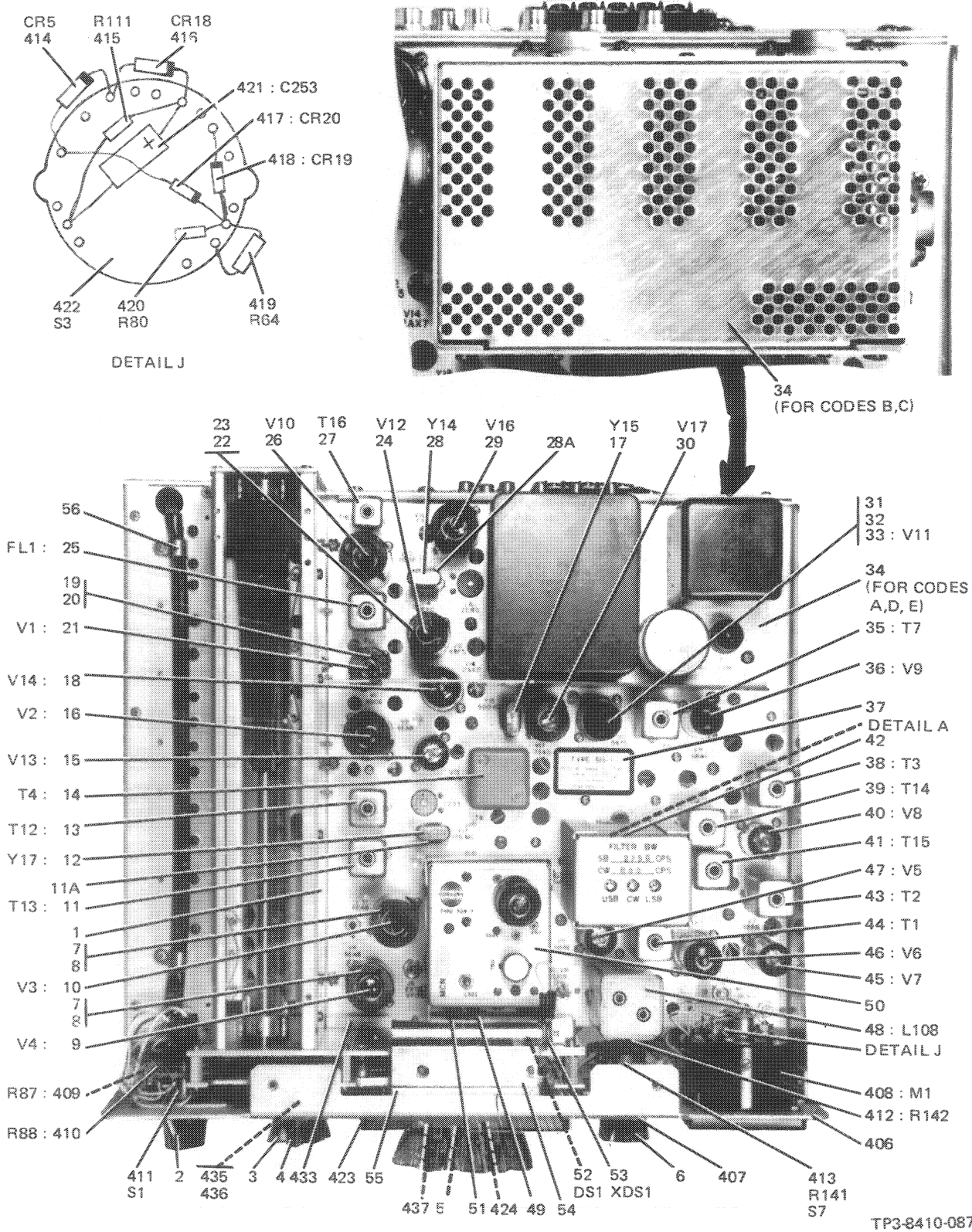

Receiver Subassembly
Figure 6-3 (Sheet 1 of 8)

GROUP ASSEMBLY PARTS LIST

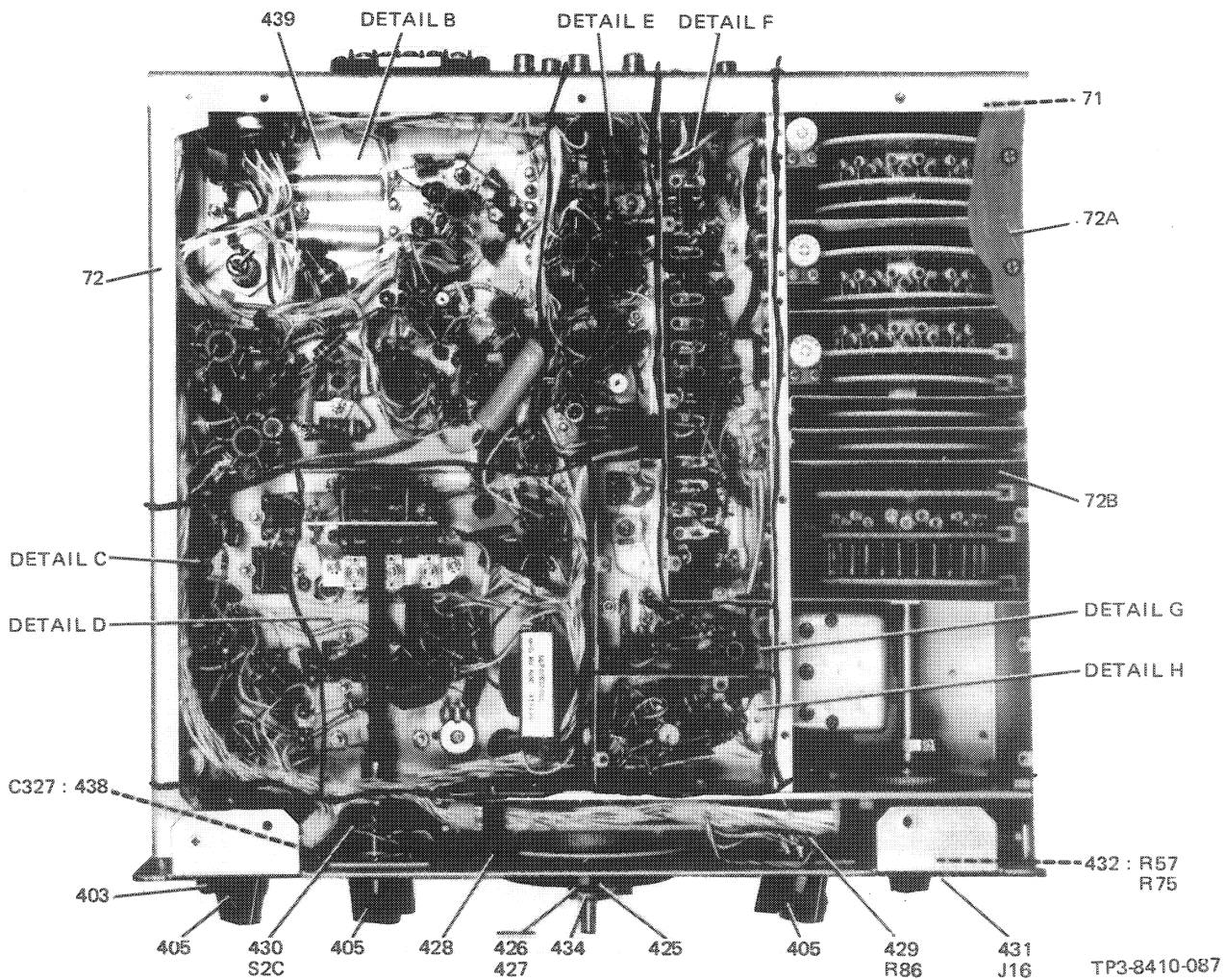
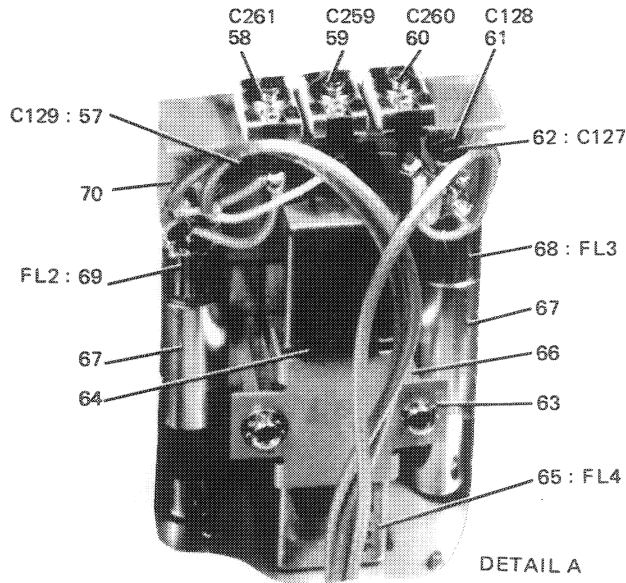

Receiver Subassembly
Figure 6-3 (Sheet 2)

GROUP ASSEMBLY PARTS LIST

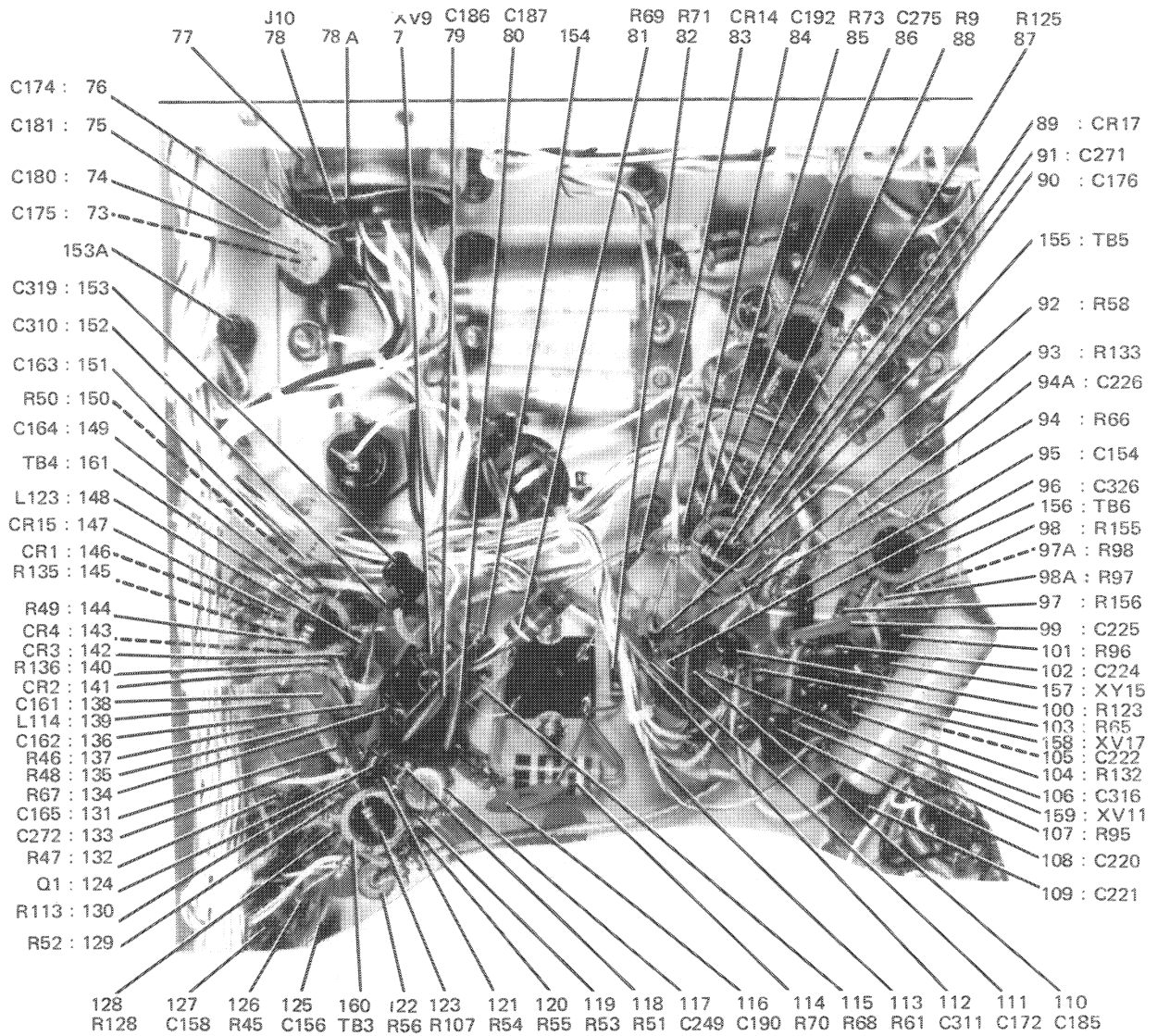

DETAIL B

TP3-8410-087

GROUP ASSEMBLY PARTS LIST

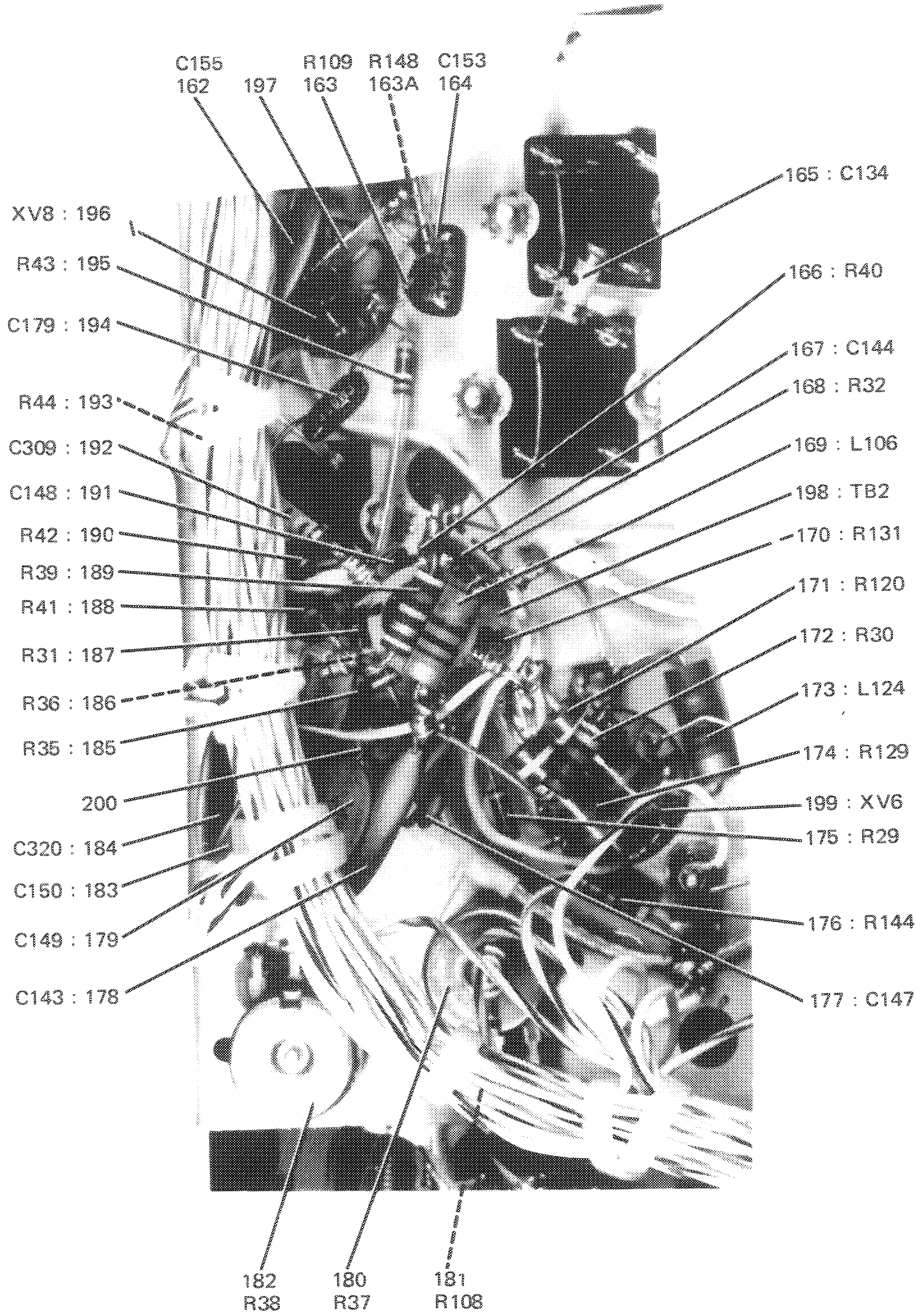

DETAIL C

TP3-8410-087

Receiver Subassembly
Figure 6-3 (Sheet 4)

GROUP ASSEMBLY PARTS LIST

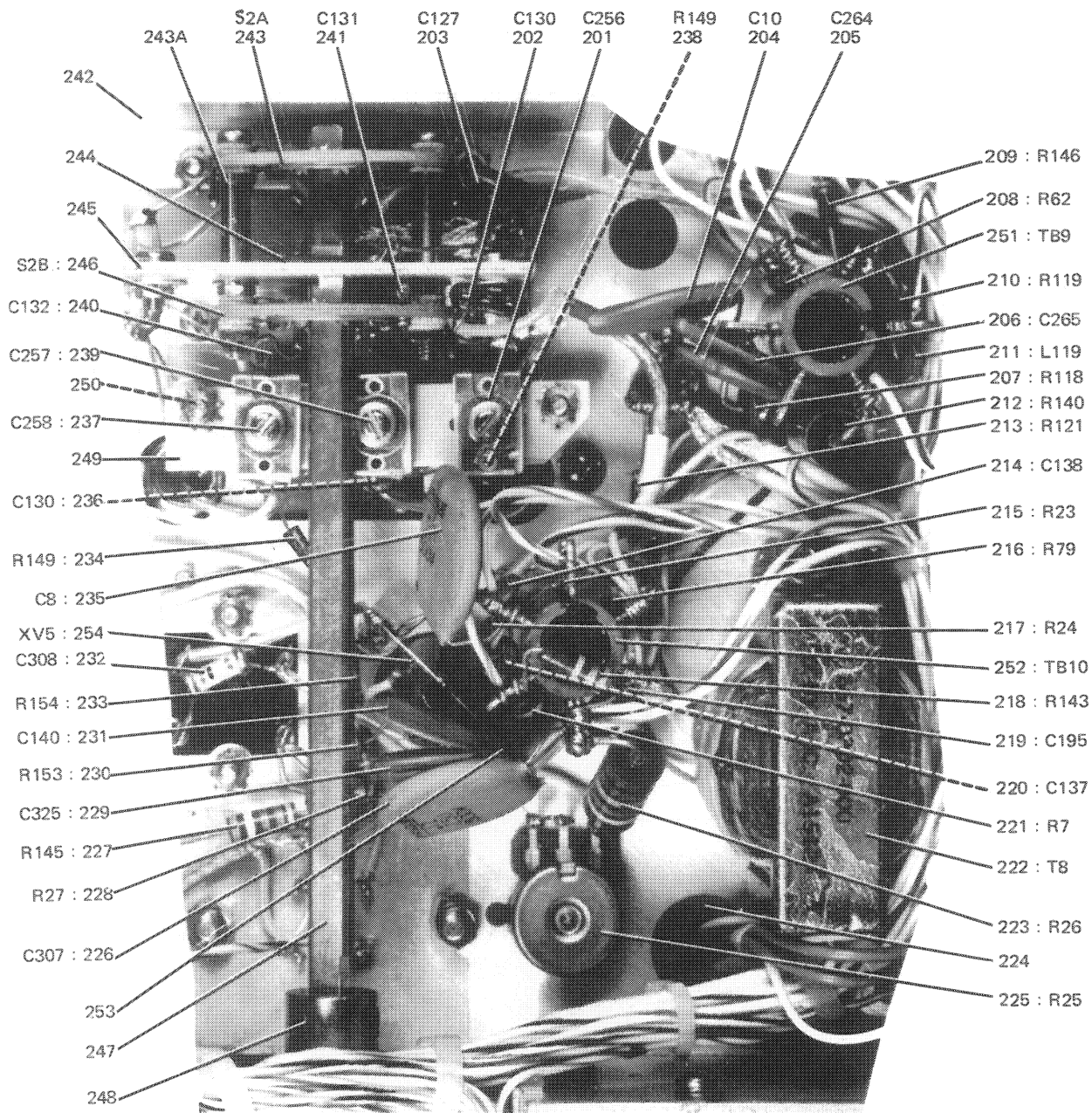

DETAIL D

TP3-8410-087

GROUP ASSEMBLY PARTS LIST

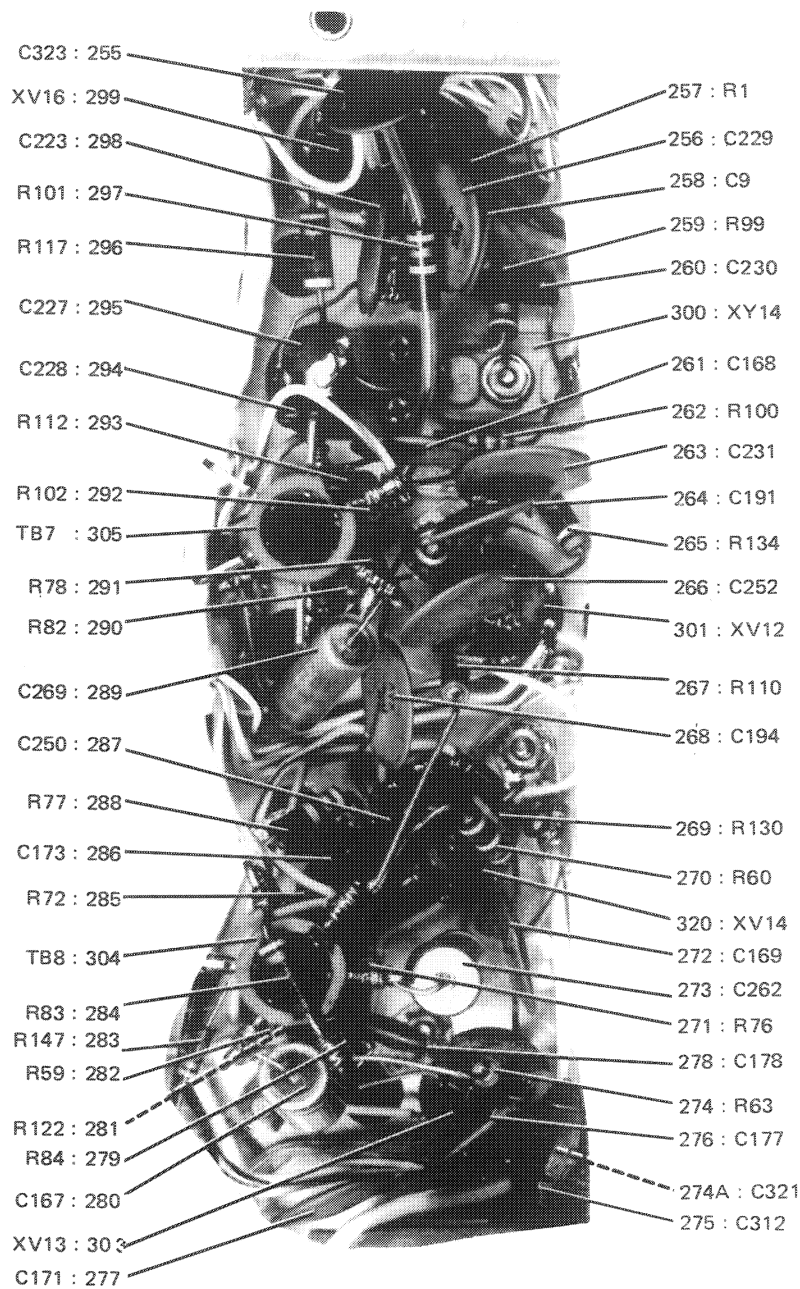

DETAIL E

TP3-8410-087

GROUP ASSEMBLY PARTS LIST

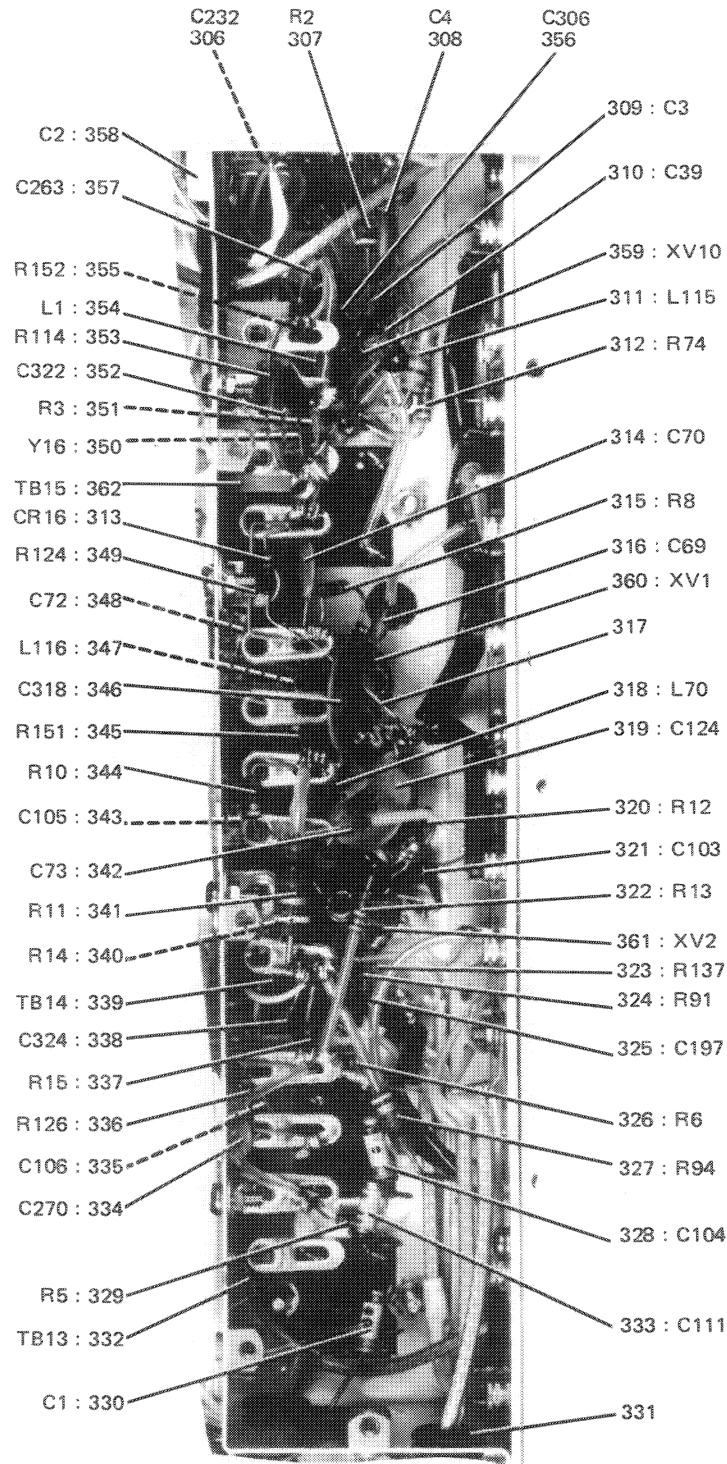

DETAIL F

TP3-8410-087

GROUP ASSEMBLY PARTS LIST

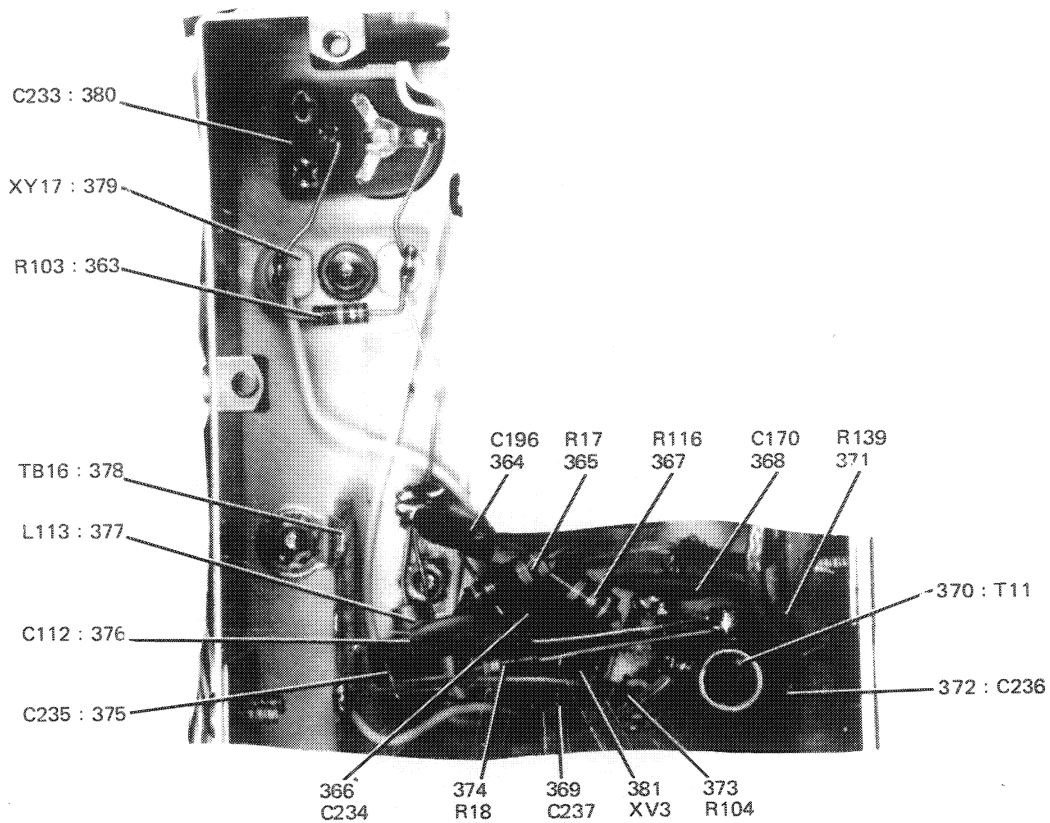

DETAIL G

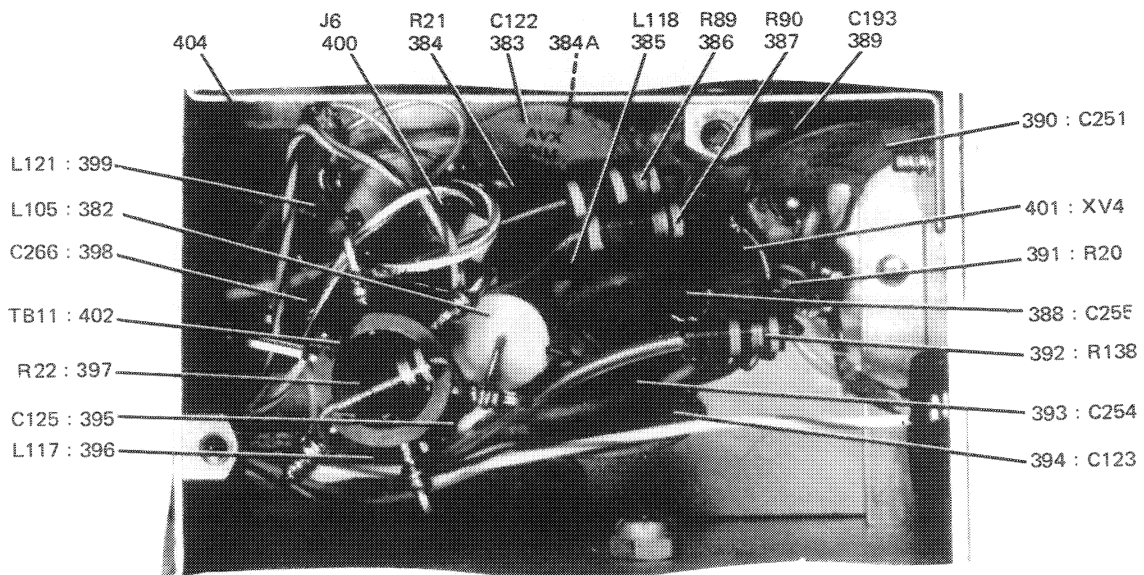

DETAIL H

TP3-8410-087

GROUP ASSEMBLY PARTS LIST

FIG - ITEM	PART NO	INDENT	DESCRIPTION	USABLE ON CODE	UNITS PER ASSY
6-3 -	547-2791-001	1	RECEIVER SUBASSEMBLY (SEE FIG 6-1-28 FOR NHA)	J	REF
-	549-0212-006	1	RECEIVER SUBASSEMBLY (SEE FIG 6-1-28 FOR NHA)	K	REF
-	549-0212-000	1	RECEIVER SUBASSEMBLY (SEE FIG 6-1-28 FOR NHA)	L	REF
-	547-2791-018	1	RECEIVER SUBASSEMBLY (SEE FIG 6-1-28 FOR NHA)	M	REF
-	547-2791-000	1	RECEIVER SUBASSEMBLY (SEE FIG 6-1-28 FOR NHA)	N	REF
1			NOT USED		
2	548-8243-004	2	KNOP		1
3	548-8244-000	2	KNOP		1
4	544-7268-002	2	KNOP		1
5	547-2645-002	2	WASHER (REPLACE WITH 553-5787-003)		1
6	546-1296-003	2	KNOP		1
7	541-8166-002	2	SHIELD,TUBE (EFF TO REV LTR CM)	J,N	5
7	M24251-6-5	2	SHIELD,TUBE (V81349) 141-0594-000 (EFF REV LTR CM)	J,N	5
7	541-8166-002	2	SHIELD, TUBE (EFF TO REV LTR BG)	K,L	5
7	M24251-6-5	2	SHIELD,TUBE (V81349) 141-0594-000 (EFF REV LTR BG)	K,L	5
7	541-8166-002	2	SHIELD,TUBE (EFF TO REV LTR CM)	M	7
7	M24251-6-5	2	SHIELD,TUBE (V81349) 141-0594-000 (EFF REV LTR CM)	M	7
8	541-6533-003	2	LINER	J,K,L,N	5
8	541-6533-003	2	LINER	M	7
9	6EAB	2	ELECTRON TUBE (V49671) 255-0379-000 V4		1
10	6EAB	2	ELECTRON TUBE (V49671) 255-0379-000 V3		1
11	X209-2	2	TRANSFORMER ASY (V81815) 278-0640-000 T13 (T12 AND T13 MUST BE REPLACED AS SET)		1
11A	504-8229-001	2	CLIP,CRYSTAL		2
12	S289-1587-000	2	XTAL UNIT,QTZ, 17500.000KHZ (V94148) 289-1587-000 Y17		1
13	X209-2	2	TRANSFORMER ASY (V81815) 278-0640-000 T12 (T12 AND T13 MUST BE REPLACED AS SET)		1
14	956-0614-410	2	TRANSFORMER,AF (V83003) 667-0522-000 T4		1
15	6AKE	2	ELECTRON TUBE (V49671) 257-0041-000 V13		1
16	6EAB	2	ELECTRON TUBE (V49671) 255-0379-000 V2		1
17	R9-7064-010	2	XTAL UNIT,QTZ, 500.0000KHZ (V88407) 289-7064-010 Y15		1
18	12AX7A	2	ELECTRON TUBE (V86684) 255-0201-000 V14		1
19	541-8169-002	2	SHIELD,TUBE (EFF TO REV LTR CM)	J,N	2
19	M24251-6-2	2	SHIELD,TUBE (V81349) 141-0591-000 (EFF REV LTR CM)	J,N	2
19	541-8169-002	2	SHIELD, TUBE (EFF TO REV LTR BG)	K,L	2
19	M24251-6-2	2	SHIELD,TUBE (V81349) 141-0591-000 (EFF REV LTR BG)	K,L	2
19	541-8169-002	2	SHIELD, TUBE (EFF TO REV LTR CM)	M	7
19	M24251-6-2	2	SHIELD,TUBE (V81349) 141-0591-000 (EFF REV LTR CM)	M	7
20	541-6532-003	2	LINER	J,K,L,N	2
20	541-6532-003	2	LINER	M	7
21	6DC6	2	ELECTRON TUBE (V86684) 255-0226-000 V1		1
22	541-6552-003	2	SHIELD,TUBE		1
23	541-6532-003	2	LINER		1
24	6RF5	2	ELECTRON TUBE (V33173) 255-0330-000 V12		1
25	X269-1	2	FILTER,LP (V81815) 241-0342-000 FL1		1
26	6EAB	2	ELECTRON TUBE (V49671) 255-0379-000 V10		1
27	X364-1	2	TRANSFORMER,RF (V81815) 278-0639-000 T16		1
28	BL289-1424-000	2	XTAL UNIT,QTZ, 100.0000KHZ (V71034) 289-1424-000 Y14		1
28A	544-2844-002	2	CLIP,CRYSTAL		1
29	6EAB	2	ELECTRON TUBE (V49671) 255-0379-000 V16		1
30	7543	2	ELECTRON TUBE (V86684) 257-0301-000 V17		1
31	541-8167-002	2	SHIELD,TUBE		1
32	541-6533-003	2	LINER	M	1
33	567C	2	ELECTRON TUBE (V01139) 253-0002-000 V11	M	1
34	547-2693-000	2	POWER SUPPLY (SEE FIG 6-4)	J,M,N	1
34	547-3930-000	2	POWER SUPPLY, 28-VDC (SEE FIG 6-5)	K,L	1

section 6
parts list

GROUP ASSEMBLY PARTS LIST

FIG - ITEM	PART NO	INDENT	DESCRIPTION	USABLE ON CODE	UNITS PER ASSY
6-3	35	X207-2	2 TRANSFORMER, IF (V81815) 278-1766-000 T7		1
	36	6BA6	2 ELECTRON TUBE (V33173) 255-0185-000 V9		1
	37	280-3014-000	2 LABEL (VA0473) 280-3014-000	K,L	1
	38	X205-2	2 TRANSFORMER, IF (V81815) 278-1765-000 T3		1
	39	X206-2	2 TRANSFORMER, IF (V81815) 278-1763-000 T14		1
	40	6BA6	2 ELECTRON TUBE (V33173) 255-0185-000 V8		1
	41	X206-2	2 TRANSFORMER, IF (V81815) 278-1763-000 T15		1
	42	547-2649-003	2 COVER, FILTER		1
	43	X201-2	2 TRANSFORMER, IF (V81815) 278-1764-000 T2		1
	44	X201-2	2 TRANSFORMER, IF (V81815) 278-1764-000 T1		1
	45	6BA6	2 ELECTRON TUBE (V33173) 255-0185-000 V7		1
	46	12AX7A	2 ELECTRON TUBE (V86684) 255-0201-000 V6		1
	47	6BA6	2 ELECTRON TUBE (V33173) 255-0185-000 V5		1
	48	X81C-1	2 COIL ASSY, IF (V81815) 278-1819-000 L108		1
	49	547-2768-002	2 SPRING		1
	50	522-2918-000	2 OSCILLATOR, 7CK-7 (NON-REPAIRABLE ITEM)		1
	51	547-2770-002	2 SHAFT, HALF COUPLING		1
	52	GE44	2 LIGHT BULB (V08806) 262-3220-000 DS1		1
	53	4159-043	2 LAMPHOLDER (V72765) 262-1210-000 XDS1		1
	54	547-2630-002	2 REFLECTOR, LIGHT		1
	55	548-1347-002	2 MASK, COUNTER		1
	56	422-C4-22-028-11 3CADP	2 STRAP, RTNG (V71785) 139-0648-000		2
	57	CM05ED510G03	2 CAPACITOR, FXD, MICA DIEI, 51PF, 2%, 500V (V81349) 912-2794-000 C129 (FOR EARLY PRODUCTION MODEL ONLY)		1
	58	T50411	2 CAPACITOR, VAR, MICA DIEI, 7 TO 60 PF, 350V (V72136) 918-0052-000 C261		1
	59	T50411	2 CAPACITOR, VAR, MICA DIEI, 7 TO 60 PF, 350V (V72136) 918-0052-000 C259		1
	60	T50411	2 CAPACITOR, VAR, MICA DIEI, 7 TO 60 PF, 350V (V72136) 918-0052-000 C260		1
	61	CM05ED510G03	2 CAPACITOR, FXD, MICA DIEI, 51PF, 2%, 500V (V81349) 912-2794-000 C128 (FOR EARLY PRODUCTION MODELS ONLY)		1
	62	CM05ED510G03	2 CAPACITOR, FXD, MICA DIEI, 51PF, 2%, 500V (V81349) 912-2794-000 C127 (FOR EARLY PRODUCTION MODELS ONLY)		1
	63	548-1335-002	2 STRAP, FILTER		1
	64	547-2642-002	2 PAD, FILTER		1
	65	293-0928-000	2 FILTER, BP (V88407) 293-0928-000 FL4		1
	66	540-9054-003	2 POST		2
	67	548-1334-002	2 RETAINER, FILTER		2
	68	526-9414-000	2 FILTER, MECHANICAL FL3	L,M,N	1
	68	526-9422-000	2 FILTER, MECHANICAL FL3	J,K	1
	69	526-9423-000	2 FILTER, MECHANICAL FL2	J,K	1
	69	526-9415-000	2 FILTER, MECHANICAL FL2	L,M,N	1
	70	547-2647-003	2 BRACKET, FILTER		1
	71	541-5181-002	2 BUTTON, CABLE		1
	72	544-9692-000	2 RAIL, LEFT		1
	72A	547-2652-003	2 COVER		1
	72B	547-2692-000	2 TUNING UNIT, RF (SEE FIG 6-6)		1
		547-2757-000	2 WIRING HARNESS	J,M,N	1
		549-0211-000	2 WIRING HARNESS	K,L	1
	73	36C175A	3 CAPACITOR, FXD, CER DIEI, 10000PF, 20%, 500V (V56289) 913-3013-000 C175		1
	74	2DDH63N103M	3 CAPACITOR, FXD, CER DIEI, 10000PF, 20%, 1000V (V71590) 913-3922-000 C180		1
	75	2DDH63N103M	3 CAPACITOR, FXD, CER DIEI, 10000PF, 20%, 1000V (V71590) 913-3922-000 C181		1
	76	36C175A	3 CAPACITOR, FXD, CER DIEI, 10000PF, 20%, 500V (V56289) 913-3013-000 C174		1
	77	61-61	3 RECEPTACLE, SHL (V02660) 372-1761-000		1

GROUP ASSEMBLY PARTS LIST

FIG - ITEM	PART NO	INDENT	DESCRIPTION	USABLE ON CODE	UNITS PER ASSY
6-3	78	86CP9-1003	3 CONNECTOR, PLUG, ELEC (VC2660) 372-1951-000 J10		1
	79A	500-1C73-0C3	2 WASHER		2
	79	36C175A	2 CAPACITOR, FXD, CER DIEL, 10000PF, 20%, 500V (V56289) 913-3013-000 C186		1
	80	36C175A	2 CAPACITOR, FXD, CER DIEL, 10000PF, 20%, 500V (V56289) 913-3013-000 C187		1
	81	RCR32G1C2KS	2 RESISTOR, FXD, CMPSN, 1K, 10%, 1W (V81349) 745-3352-000 R69		1
	82	PCR20G122KS	2 RESISTOR, FXD, CMPSN, 1.2K, 10%, 1/2W (V81349) 745-1356-000 R71		1
	83	1N482A	2 SEMICONV DEVICE (V07263) 353-2648-000 CR14		1
	84	5C11A	2 CAPACITOR, FXD, CER DIEL, 0.47UF, M20%P80%, 25V (V56289) 913-3804-000 C192		1
	85	RCR20G224KS	2 RESISTOR, FXD, CMPSN, 0.22MEGC, 10%, 1/2W (V81349) 745-1450-000 R73		1
	86	36C175A	2 CAPACITOR, FXD, CER DIEL, 10000PF, 20%, 500V (V56289) 913-3013-000 C275		1
	87	RCR07G224KS	2 RESISTOR, FXD, CMPSN, 0.22MEGC, 10%, 1/4W (V81349) 745-0833-000 R125		1
	88	RCR07G473KS	2 RESISTOR, FXD, CMPSN, 47K, 10%, 1/4W (V81349) 745-0809-000 R9		1
	89	1N67A	2 SEMICONV DEVICE (V03877) 353-0147-000 CR17		1
	90	D31536	2 CAPACITOR, FXD, ELCTLT, 5UF, M10%P75%, 50V (V56289) 183-1162-000 C176		1
	91	36C175A	2 CAPACITOR, FXD, CER DIEL, 10000PF, 20%, 500V (V56289) 913-3013-000 C271		1
	92	RCR20G332KS	2 RESISTOR, FXD, CMPSN, 3.3K, 10%, 1/2W (V81349) 745-1373-000 R58		1
	93	RCR20G101KS	2 RESISTOR, FXD, CMPSN, 100 OHMS, 10%, 1/2W (V81349) 745-1310-000 R133 (REPLACE WITH 745-0713-000)		1
	93	RCR07G101KS	2 RESISTOR, FXD, CMPSN, 100 OHMS, 10%, 1/4W (V81349) 745-0713-000 R133 (REPLACES 745 1310 000)		1
	94	RCR20G332KS	2 RESISTOR, FXD, CMPSN, 3.3K, 10%, 1/2W (V81349) 745-1373-000 R66		1
	94A	36C175A	2 CAPACITOR, FXD, CER DIEL, 10000PF, 20%, 500V (V56289) 913-3013-000 C226 (FOR EARLY PRODUCTION MODELS ONLY)		1
	95	40C73A1	2 CAPACITOR, FXD, CER DIEL, 1000PF, 20%, 500V (V56289) 913-3009-000 C154		1
	96	40C73A1	2 CAPACITOR, FXD, CER DIEL, 1000PF, 20%, 500V (V56289) 913-3009-000 C326 (FOR LATER PRODUCTION MODELS ONLY)		1
	97	RCR07G183KS	2 RESISTOR, FXD, CMPSN, 18K, 10%, 1/4W (V81349) 745-0794-000 R156 (FOR LATER PRODUCTION MODELS ONLY)		1
	97A	RCR20G102KS	2 RESISTOR, FXD, CMPSN, 1K, 10%, 1/2W (V81349) 745-1352-000 R98 (FOR EARLY PRODUCTION MODELS ONLY)		1
	98	RCR07G563KS	2 RESISTOR, FXD, CMPSN, 56K, 10%, 1/4W (V81349) 745-0812-000 R155 (FOR LATER PRODUCTION MODELS ONLY)		1
	98A	RCR20G562KS	2 RESISTOR, FXD, CMPSN, 5.6K, 10%, 1/2W (V81349) 745-1384-000 R97 (FOR EARLY PRODUCTION MODELS ONLY)		1
	99	36C175A	2 CAPACITOR, FXD, CER DIEL, 10000PF, 20%, 500V (V56289) 913-3013-000 C225		1
	100	RCR07G393KS	2 RESISTOR, FXD, CMPSN, 39K, 10%, 1/4W (V81349) 745-0806-000 R123		1
	101	PCR20G104KS	2 RESISTOR, FXD, CMPSN, 0.10MEGC, 10%, 1/2W (V81349) 745-1436-000 R96		1
	102	DM15F471J300WV4C R	2 CAPACITOR, FXD, MICA DIEL, 470PF, 5%, 500V (V72136) 912-2864-000 C224 (REPLACE WITH 912-2858-000)		1
	102	CM05FD391J03	2 CAPACITOR, FXD, MICA DIEL, 390PF, 5%, 500V (V81349) 912-2858-000 C224 (REPLACES 912-2864-000)		1

section 6
parts list

GROUP ASSEMBLY PARTS LIST

FIG - ITEM	PART NO	INDENT	DESCRIPTION	USABLE ON CODE	UNITS PER ASSY
6-3 103	RCR20G102KS	2	RESISTOR,FXD, CMPSN, 1K, 10%, 1/2W (V81349) 745-1352-000 R65		1
104	RCRC7G47CKS	2	RESISTOR,FXD, CMPSN, 47 OHMS, 10%, 1/4W (V81349) 745-0701-000 R132		1
105	DM15F101K500WV4C R	2	CAPACITOR,FXD, MICA DIEI, 100PF, 10%, 500V (V72136) 912-2817-000 C222		1
106	D29343	2	CAPACITOR,FXD, ELCTLT, 4UF, M10%P100%, 350V (V56289) 183-1783-000 C316		1
107	RCR20G105KS	2	RESISTOR,FXD, CMPSN, 1MEGO, 10%, 1/2W (V81349) 745-1478-000 F95		1
108	DM15C150K500WV4C R	2	CAPACITOR,FXD, MICA DIEI, 15PF, 10%, 500V (V72136) 912-2760-000 C220		1
109	41C92	2	CAPACITOR,FXD, CER DIEI, 0.1UF, M20%P80%, 500V (V56289) 913-3152-000 C221		1
110	36C175A	2	CAPACITOR,FXD, CER DIEI, 10000PF, 20%, 500V (V56289) 913-3013-000 C185		1
111	36C175A	2	CAPACITOR,FXD, CER DIEI, 10000PF, 20%, 500V (V56289) 913-3013-000 C172		1
112	CM05FD331J03	2	CAPACITOR,FXD, MICA DIEI, 330PF, 5%, 500V (V81349) 912-2852-000 C311		1
113	RCR20G102KS	2	RESISTOR,FXD, CMPSN, 1K, 10%, 1/2W (V81349) 745-1352-000 R61		1
114	RCR42G393KS	2	RESISTOR,FXD, CMPSN, 39K, 10%, 2W (V81349) 745-5719-000 R70		1
115	RCR20G82CKS	2	RESISTOR,FXD, CMPSN, 82 OHMS, 10%, 1/2W (V81349) 745-1307-000 R68		1
116	36C175A	2	CAPACITOR,FXD, CER DIEI, 10000PF, 20%, 500V (V56289) 913-3013-000 C190		1
117	B41283-47-40	2	CAPACITOR,FXD, ELCTLT, 50UF, M20%P50%, 35V (V25088) 183-1295-540 C249		1
118	RCRC7G272KS	2	RESISTOR,FXD, CMPSN, 2.7K, 10%, 1/4W (V81349) 745-0764-000 R51		1
119	RCRC7G332KS	2	RESISTOR,FXD, CMPSN, 3.3K, 10%, 1/4W (V81349) 745-0767-000 R53		1
120	RCR20G682KS	2	RESISTOR,FXD, CMPSN, 6.8K, 10%, 1/2W (V81349) 745-1387-000 R55		1
121	RCRC7G223KS	2	RESISTOR,FXD, CMPSN, 22K, 10%, 1/4W (V81349) 745-0797-000 R54		1
122	RCR42G223KS	2	RESISTOR,FXD, CMPSN, 22K, 10%, 2W (V81349) 745-5708-000 R56		1
123	RCRC7G271KS	2	RESISTOR,FXD, CMPSN, 270 OHMS, 10%, 1/4W (V81349) 745-0728-000 R107		1
124	2N388	2	TRANSISTOR (V01295) 352-0241-000 Q1 (REPLACE WITH 618-4921-027)		1
124	618-4921-027	2	TRANSISTOR Q1 (REPLACES 352-0241-000) (MODIFIED 2N222A TRANSISTOR)		1
125	36C175A	2	CAPACITOR,FXD, CER DIEI, 10000PF, 20%, 500V (V56289) 913-3013-000 C156		1
126	RCR20G102KS	2	RESISTOR,FXD, CMPSN, 1K, 10%, 1/2W (V81349) 745-1352-000 R45		1
127	CM05ED470J03	2	CAPACITOR,FXD, MICA DIEI, 47PF, 5%, 500V (V81349) 912-2792-000 C158		1
128	RCRC7G222KS	2	RESISTOR,FXD, CMPSN, 2.2K, 10%, 1/4W (V81349) 745-0761-000 R128		1
129	RCRC7G333KS	2	RESISTOR,FXD, CMPSN, 33K, 10%, 1/4W (V81349) 745-0803-000 R52		1
130	RCR20G473KS	2	RESISTOR,FXD, CMPSN, 47K, 10%, 1/2W (V81349) 745-1422-000 R113		1
131	55C23A2	2	CAPACITOR,FXD, CER DIEI, 0.05UF, M20%P80%, 50V (V56289) 913-3885-000 C165		1
132	RCRC7G56CKS	2	RESISTOR,FXD, CMPSN, 56 OHMS, 10%, 1/4W (V81349) 745-0704-000 R47		1
133	36C175A	2	CAPACITOR,FXD, CER DIEI, 10000PF, 20%, 500V (V56289) 913-3013-000 C272		1

GROUP ASSEMBLY PARTS LIST

FIG - ITEM	PART NO	INDENT	DESCRIPTION	USABLE ON CODE	UNITS PER ASSY
6-3 134	RCRC07G104KS	2	RESISTOR,FXD, CMPSN, 0.10MEGO, 10%, 1/4W (V81349) 745-0821-000 R67		1
135	RCRC07G152KS	2	RESISTOR,FXD, CMPSN, 1.5K, 10%, 1/4W (V81349) 745-0755-000 R48		1
136	D33212	2	CAPACITOR,FXD, ELCTLT, 2UF, M10%P75%, 50V (V56289) 183-1183-000 C162		1
137	RCRC07G152KS	2	RESISTOR,FXD, CMPSN, 1.5K, 10%, 1/4W (V81349) 745-0755-000 R46		1
138	841-000X5V0223Z	2	CAPACITOR,FXD, CER DIEL, 22000PF, M20%P100%, 500V (V72982) 913-3014-000 C161 (REPLACE WITH 913-2142-000)		1
138	33C2	2	CAPACITOR,FXD, CER DIEL, 0.02UF, 20%, 500V (V56289) 913-2142-000 C161 (REPLACES 913-3014-000)		1
139	BS217	2	COIL,RF, 220UH (V99800) 240-0198-000 L114 (REPLACE WITH 240-2715-410)		1
139	MS75089-15	2	COIL,RF, 220UH (V96906) 240-2715-410 L114 (REPLACES 240-0198-000)		1
140	RCRC07G151KS	2	RESISTOR,FXD, CMPSN, 150 OHMS, 10%, 1/4W (V81349) 745-0719-000 R136		1
141	1N34A	2	SEMICOND DEVICE (V03877) 353-2780-000 CR2		1
142	1N34A	2	SEMICOND DEVICE (V03877) 353-2780-000 CR3		1
143	1N34A	2	SEMICOND DEVICE (V03877) 353-2780-000 CR4		1
144	RCRC07G104KS	2	RESISTOR,FXD, CMPSN, 0.10MEGO, 10%, 1/4W (V81349) 745-0821-000 R49		1
145	RCRC07G151KS	2	RESISTOR,FXD, CMPSN, 150 OHMS, 10%, 1/4W (V81349) 745-0719-000 R135		1
146	1N34A	2	SEMICOND DEVICE (V03877) 353-2780-000 CR1		1
147	1N34A	2	SEMICOND DEVICE (V03877) 353-2780-000 CR15		1
148	WEE-470	2	COIL,RF, 470UH (V24759) 240-1192-000 L123		1
149	36C175A	2	CAPACITOR,FXD, CER DIEL, 10000PF, 20%, 500V (V56289) 913-3013-000 C164		1
150	RCRC07G104KS	2	RESISTOR,FXD, CMPSN, 0.10MEGO, 10%, 1/4W (V81349) 745-0821-000 R50		1
151	19C372	2	CAPACITOR,FXD, CER DIEL, 470PF, 20%, 500V (V56289) 913-3007-000 C163		1
152	44C7A	2	CAPACITOR,FXD, CER DIEL, 4700PF, 20%, 500V (V56289) 913-3012-000 C310		1
153	CM05FD331J03	2	CAPACITOR,FXD, MICA DIEL, 330PF, 5%, 500V (V81349) 912-2852-000 C319		1
153A	RTMT12M	2	TERMINAL,STUD (V91663) 306-0976-000		10
154	502-1427-002	2	SHIELD,SOCKET		1
155	6H12	2	TERMINAL BOARD (V82893) 306-0909-000 TB5		1
156	6H12	2	TERMINAL BOARD (V82893) 306-0909-000 TB6		1
157	TS0205CG1	2	SOCKET,XTAL (V81349) 292-0082-000 XY15		1
158	TS102P01	2	SOCKET,ELECTRON (V81349) 220-1111-000 XV17		1
159	TS103P01	2	SOCKET,ELECTRON (V81349) 220-1103-000 XV11 (REPLACE WITH 220-1274-000)		1
159	TS103P02	2	SOCKET,ELECTRON (V81349) 220-1274-000 XV11 (REPLACES 220-1103-000)		1
160	6H12	2	TERMINAL BOARD (V82893) 306-0909-000 TB3		1
161	6H12	2	TERMINAL BOARD (V82893) 306-0909-000 TB4		1
162	36C175A	2	CAPACITOR,FXD, CER DIEL, 10000PF, 20%, 500V (V56289) 913-3013-000 C155		1
163	RCRC07G125KS	2	RESISTOR,FXD, CMPSN, 1.2MEGO, 10%, 1/4W (V81349) 745-0860-000 R109		1
163A	RCRC07G395KS	2	RESISTOR,FXD, CMPSN, 3.9MEGO, 10%, 1/4W (V81349) 745-0878-000 R148		AR
164	CM05FD121J03	2	CAPACITOR,FXD, MICA DIEL, 120PF, 5%, 500V (V81349) 912-2822-000 C153		1
165	CC20CJ030D	2	CAPACITOR,FXD, CER DIEL, 3PF, 1/2PF, 500V (V81349) 916-0145-000 C134		1
166	RCRC07G101KS	2	RESISTOR,FXD, CMPSN, 100 OHMS, 10%, 1/4W (V81349) 745-0713-000 R40		1
167	40C73A1	2	CAPACITOR,FXD, CER DIEL, 1000PF, 20%, 500V (V56289) 913-3009-000 C144		1

section 6
parts list

GROUP ASSEMBLY PARTS LIST

FIG - ITEM	PART NO	INDENT	DESCRIPTION	USABLE ON CODE	UNITS PER ASSY
6-3 168	RRC7G334KS	2	RESISTOR,FXD, CMPSN, 0.33MEGO, 10%, 1/4W (V81349) 745-0839-000 R32		1
169	MS90539-15	2	COIL,RF, 1000UH (V96906) 240-2540-000 L106		1
170	RCR20G10CKS	2	RESISTOR,FXD, CMPSN, 10 OHMS, 10%, 1/2W (V81349) 745-1268-000 R131		1
171	RCR32G680KS	2	RESISTOR,FXD, CMPSN, 68 OHMS, 10%, 1W (V81349) 745-3303-000 R120		1
172	RCR20G121KS	2	RESISTOR,FXD, CMPSN, 120 OHMS, 10%, 1/2W (V81349) 745-1314-000 R30		1
173	MS90540-07	2	COIL,RF, 2000UH (V96906) 240-2547-000 L124		1
174	RCR32G121KS	2	RESISTOR,FXD, CMPSN, 120 OHMS, 10%, 1W (V81349) 745-3314-000 R129		1
175	RRC7G470KS	2	RESISTOR,FXD, CMPSN, 47 OHMS, 10%, 1/4W (V81349) 745-0701-000 R29		1
176	RCR20G474KS	2	RESISTOR,FXD, CMPSN, 0.47MEGO, 10%, 1/2W (V81349) 745-1464-000 R144		1
177	40C73A1	2	CAPACITOR,FXD, CER DIEL, 1000PF, 20%, 500V (V56289) 913-3009-000 C147		1
178	41C92	2	CAPACITOR,FXD, CER DIEL, 0.1UF, M20%P80%, 500V (V56289) 913-3152-000 C143		1
179	36C175A	2	CAPACITOR,FXD, CER DIEL, 10000PF, 20%, 500V (V56289) 913-3013-000 C149		1
180	376-0201-000	2	RESISTOR,VAR, CMPSN, 250 OHMS, 20%, 0.2W (V71450) 376-0201-000 R37 (REPLACE WITH 376-4621-000)		1
180	WR5453	2	RESISTOR,VAR, 250 OHMS, 20%, 0.2W (V71450) 376-4621-000 R37 (REPLACES 376-0201-000)		1
181	RCR20G470KS	2	RESISTOR,FXD, CMPSN, 47 OHMS, 10%, 1/2W (V81349) 745-1296-000 R108		1
182	376-0203-000	2	RESISTOR,VAR, CMPSN, 1K, 20%, 0.2W (V71450) 376-0203-000 R38 (REPLACE WITH 376-4623-000)		1
182	WR5455	2	RESISTOR,VAR, 1K, 20%, 0.2W (V71450) 376-4623-000 R38 (REPLACES 376-0203-000)		1
183	36C175A	2	CAPACITOR,FXD, CER DIEL, 10000PF, 20%, 500V (V56289) 913-3013-000 C150		1
184	36C175A	2	CAPACITOR,FXD, CER DIEL, 10000PF, 20%, 500V (V56289) 913-3013-000 C320		1
185	RRC7G104KS	2	RESISTOR,FXD, CMPSN, 0.10MEGO, 10%, 1/4W (V81349) 745-0821-000 R35		1
186	RCR7G473KS	2	RESISTOR,FXD, CMPSN, 47K, 10%, 1/4W (V81349) 745-0809-000 R36		1
187	RCR20G102KS	2	RESISTOR,FXD, CMPSN, 1K, 10%, 1/2W (V81349) 745-1352-000 R31		1
188	RCR32G153KS	2	RESISTOR,FXD, CMPSN, 15K, 10%, 1W (V81349) 745-3401-000 R41		1
189	RCR20G473KS	2	RESISTOR,FXD, CMPSN, 47K, 10%, 1/2W (V81349) 745-1422-000 R39		1
190	RCR20G102KS	2	RESISTOR,FXD, CMPSN, 1K, 10%, 1/2W (V81349) 745-1352-000 R42		1
191	19C372	2	CAPACITOR,FXD, CER DIEL, 470PF, 20%, 500V (V56289) 913-3007-000 C148		1
192	CC20CK020C	2	CAPACITOR,FXD, CER DIEL, 2PF, 1/4PF, 500V (V81349) 916-0075-000 C309		1
193	RCR20G102KS	2	RESISTOR,FXD, CMPSN, 1K, 10%, 1/2W (V81349) 745-1352-000 R44		1
194	CM05ED390J03	2	CAPACITOR,FXD, MICA DIEL, 39PF, 5%, 500V (V81349) 912-2786-000 C179		1
195	RCR07G395KS	2	RESISTOR,FXD, CMPSN, 3.9MEGO, 10%, 1/4W (V81349) 745-0878-000 R43		1
196	TS102P01	2	SOCKET,ELECTRON (V81349) 220-1111-000 XV8 (REPLACE WITH 220-1152-000)	J,K,L,N	1
196	TS102P02	2	SOCKET,ELECTRON (V81349) 220-1152-000 XV8 (REPLACES 220-1111-000)	J,K,L,N	1
196	TS102P01	2	SOCKET,ELECTRON (V81349) 220-1111-000 XV8	D	1

GROUP ASSEMBLY PARTS LIST

FIG - ITEM	PART NO	INDENT	DESCRIPTION	USABLE ON CODE	UNITS PER ASSY
6-3	197	502-1427-002	2 SHIELD, SOCKET		1
	198	6H12	2 TERMINAL BOARD (V82893) 306-0909-000 TB2		1
	199	TS103P01	2 SOCKET, ELECTRON (V81349) 220-1103-000 XV6 (REPLACE WITH 220 1274 000)		1
	199	TS103P02	2 SOCKET, ELECTRON (V81349) 220-1274-000 XV6 (REPLACES 220-1103-000)		1
	200	502-1427-002	2 SHIELD, SOCKET		1
	201	T50411	2 CAPACITOR, VAR, MICA DIEI, 7 TO 60 PF, 350V (V72136) 918-0052-000 C256		1
	202	CM05ED62CG03	2 CAPACITOR, FXD, MICA DIEI, 62PF, 2%, 500V (V81349) 912-2800-000 C130 (FOR LATER PRODUCTION MODELS ONLY)		1
	203	CM05ED510G03	2 CAPACITOR, FXD, MICA DIEI, 51PF, 2%, 500V (V81349) 912-2794-000 C127 (FOR LATER PRODUCTION MODELS ONLY)		1
	204	41C92	2 CAPACITOR, FXD, CER DIEI, 0.1UF, M20%P80%, 500V (V56289) 913-3152-000 C10		1
	205	20DD63G104XAA	2 CAPACITOR, FXD, CER DIEI, 1UF, M30%P80%, 75V (V71590) 913-3794-000 C264		1
	206	20DD63G104XAA	2 CAPACITOR, FXD, CER DIEI, 1UF, M30%P80%, 75V (V71590) 913-3794-000 C265		1
	207	RCR32G680KS	2 RESISTOR, FXD, CMPSN, 68 OHMS, 10%, 1W (V81349) 745-3303-000 R118		1
	208	RCR20G102KS	2 RESISTOR, FXD, CMPSN, 1K, 10%, 1/2W (V81349) 745-1352-000 R62		1
	209	RCR07G221KS	2 RESISTOR, FXD, CMPSN, 220 OHMS, 10%, 1/4W (V81349) 745-0725-000 R146		1
	210	RCR42G330KS	2 RESISTOR, FXD, CMPSN, 33 OHMS, 10%, 2W (V81349) 745-5589-000 R119		1
	211	4422-4-26	2 COIL, RF, 10UH (V82142) 240-0164-000 L119		1
	212	RCR42G330KS	2 RESISTOR, FXD, CMPSN, 33 OHMS, 10%, 2W (V81349) 745-5589-000 R140		1
	213	RCR20G471KS	2 RESISTOR, FXD, CMPSN, 470 OHMS, 10%, 1/2W (V81349) 745-1338-000 R121		1
	214	19C372	2 CAPACITOR, FXD, CER DIEI, 470PF, 20%, 500V (V56289) 913-3007-000 C138		1
	215	RCR07G473KS	2 RESISTOR, FXD, CMPSN, 47K, 10%, 1/4W (V81349) 745-0809-000 R23		1
	216	RCR20G222KS	2 RESISTOR, FXD, CMPSN, 2.2K, 10%, 1/2W (V81349) 745-1366-000 R79		1
	217	RCR07G224KS	2 RESISTOR, FXD, CMPSN, 0.22MEGO, 10%, 1/4W (V81349) 745-0833-000 R24		1
	218	RCR20G224KS	2 RESISTOR, FXD, CMPSN, 0.22MEGO, 10%, 1/2W (V81349) 745-1450-000 R143		1
	219	36C175A	2 CAPACITOR, FXD, CER DIEI, 10000PF, 20%, 500V (V56289) 913-3013-000 C195		1
	220	19C372	2 CAPACITOR, FXD, CER DIEI, 470PF, 20%, 500V (V56289) 913-3007-000 C137		1
	221	RCR32G102KS	2 RESISTOR, FXD, CMPSN, 1K, 10%, 1W (V81349) 745-3352-000 R7		1
	222	E13657	2 TRANSFORMER, AF (V32712) 667-0302-000 T8		1
	223	RCR42G223KS	2 RESISTOR, FXD, CMPSN, 22K, 10%, 2W (V81349) 745-5708-000 R26		1
	224	905	2 GROMMET, RBR (V75543) 201-1060-000		4
	225	VY9692	2 RESISTOR, VAR, 2.5K, 20%, 0.2W (V71450) 376-0204-000 R25 (REPLACE WITH 376-4619-000)		1
	225	WR5451	2 RESISTOR, VAR, 2.5K, 30%, 0.2W (V71450) 376-4619-000 R25 (REPLACES 376-0204-000)		1
	226	41C92	2 CAPACITOR, FXD, CER DIEI, 0.1UF, M20%P80%, 500V (V56289) 913-3152-000 C307		1
	227	RCR20G3R9JS	2 RESISTOR, FXD, CMPSN, 3.9 OHMS, 5%, 1/2W (V81349) 745-1539-000 R145		1
	228	RCR20G102KS	2 RESISTOR, FXD, CMPSN, 1K, 10%, 1/2W (V81349) 745-1352-000 R27		1

section 6
parts list

GROUP ASSEMBLY PARTS LIST

FIG - ITEM	PART NO	INDENT	DESCRIPTION	USABLE ON CODE	UNITS PER ASSY
6-3 229	36C175A	2	CAPACITOR,FXD, CER DIEI, 10000PF, 20%, 500V (V56289) 913-3013-000 C325		1
230	RCRC7G104KS	2	RESISTOR,FXD, CMPSN, 0.10MEGO, 10%, 1/4W (V81349) 745-0821-000 R153		1
231	36C175A	2	CAPACITOR,FXD, CER DIEI, 10000PF, 20%, 500V (V56289) 913-3013-000 C140		1
232	CC20CK02CC	2	CAPACITOR,FXD, CER DIEI, 2PF, 1/4PF, 500V (V81349) 916-0075-000 C308		1
233	RCRC7G104KS	2	RESISTOR,FXD, CMPSN, 0.10MEGO, 10%, 1/4W (V81349) 745-0821-000 R154		1
234	RCRC7G223KS	2	RESISTOR,FXD, CMPSN, 22K, 10%, 1/4W (V81349) 745-0797-000 R149 (ALTERNATE LOCATION FOR ITEM 238)		AR
235	41C92	2	CAPACITOR,FXD, CER DIEI, 0.1UF, M20%P80%, 500V (V56289) 913-3152-000 C8		1
236	CM05ED620G03	2	CAPACITOR,FXD, MICA DIEI, 62PF, 2%, 500V (V81349) 912-2800-000 C130 (FOR EARLY PRODUCTION MODELS ONLY)		1
237	T50411	2	CAPACITOR,VAR, MICA DIEI, 7 TO 60 PF, 350V (V72136) 918-0052-000 C258		1
238	RCRC7G223KS	2	RESISTOR,FXD, CMPSN, 22K, 10%, 1/4W (V81349) 745-0797-000 R149 (ALTERNATE LOCATION FOR ITEM 234)		1
239	T50411	2	CAPACITOR,VAR, MICA DIEI, 7 TO 60 PF, 350V (V72136) 918-0052-000 C257		1
240	CM05ED620G03	2	CAPACITOR,FXD, MICA DIEI, 62PF, 2%, 500V (V81349) 912-2800-000 C132 (FOR EARLY PRODUCTION MODELS ONLY)		1
241	CM05ED620G03	2	CAPACITOR,FXD, MICA DIEI, 62PF, 2%, 500V (V81349) 912-2800-000 C131 (FOR EARLY PRODUCTION MODELS ONLY)		1
242	547-2638-002	2	PLATE, ELECTRICAL SHIELD		1
243	210874F	2	SWITCH SECT,RTR (V76854) 269-2223-000 S2A		1
243A	898C-2 1-2	2	SPACER,SLV (V76854) 269-1407-000		2
244	547-2699-002	2	CLIP,ELECTRICAL		1
245	547-2628-002	2	BRACKET,SWITCH FILTER		1
246	210874F	2	SWITCH SECT,RTR (V76854) 269-2223-000 S2B		1
247	547-2698-002	2	SHAFT STRAIGHT-GROVED		1
248	39003	2	COUPLING,SHAFT (V76487) 015-0257-000		1
249	547-2629-002	2	RETAINER, CAPACITOR		1
250	541-5983-002	2	SPACER		2
251	6H12	2	TERMINAL BOARD (V82893) 306-0909-000 TB9		1
252	6H12	2	TERMINAL BOARD (V82893) 306-0909-000 TB10		1
253	502-1427-002	2	SHIELD, SOCKET		1
254	TS102P01	2	SOCKET,ELECTRON (V81349) 220-1111-000 XV5 (REPLACE WITH 220-1152-000)	J,K,L,N	1
254	TS102P02	2	SOCKET,ELECTRON (V81349) 220-1152-000 XV5 (REPLACES 220-1111-000)	J,K,L,N	1
254	TS102P01	2	SOCKET,ELECTRON (V81349) 220-1111-000 XV5	D	1
255	36C175A	2	CAPACITOR,FXD, CER DIEI, 10000PF, 20%, 500V (V56289) 913-3013-000 C323		1
256	36C175A	2	CAPACITOR,FXD, CER DIEI, 10000PF, 20%, 500V (V56289) 913-3013-000 C229		1
257	RCR20G271JS	2	RESISTOR,FXD, CMPSN, 270 OHMS, 5%, 1/2W (V81349) 745-1327-000 R1		1
258	44C7A	2	CAPACITOR,FXD, CER DIEI, 4700PF, 20%, 500V (V56289) 913-3012-000 C9		1
259	RCR20G105KS	2	RESISTOR,FXD, CMPSN, 1MEGO, 10%, 1/2W (V81349) 745-1478-000 R99		1
260	DM15F101K500WV4C R	2	CAPACITOR,FXD, MICA DIEI, 100PF, 10%, 500V (V72136) 912-2817-000 C230		1
261	36C175A	2	CAPACITOR,FXD, CER DIEI, 10000PF, 20%, 500V (V56289) 913-3013-000 C168		1
262	RCR20G334KS	2	RESISTOR,FXD, CMPSN, 0.33MEGO, 10%, 1/2W (V81349) 745-1457-000 R100 (REPLACE WITH 745-1450-000)		1

GROUP ASSEMBLY PARTS LIST

FIG - ITEM	PART NO	INDENT	DESCRIPTION	USABLE ON CODE	UNITS PER ASSY
6-3 262	RCR20G224KS	2	RESISTOR,FXD, CMPSN, 0.22MEGO, 10%, 1/2W (V81349) 745-1450-000 R100 (REPLACES 745-1457-000)		1
263	36C175A	2	CAPACITOR,FXD, CER DIEFL, 10000PF, 20%, 500V (V56289) 913-3013-000 C231		1
264	36C175A	2	CAPACITOR,FXD, CER DIEFL, 10000PF, 20%, 500V (V56289) 913-3013-000 C191		1
265	RCR20G390KS	2	RESISTOR,FXD, CMPSN, 39 OHMS, 10%, 1/2W (V81349) 745-1293-000 R134		1
266	36C175A	2	CAPACITOR,FXD, CER DIEFL, 10000PF, 20%, 500V (V56289) 913-3013-000 C252		1
267	RCR20G332KS	2	RESISTOR,FXD, CMPSN, 3.3K, 10%, 1/2W (V81349) 745-1373-000 R110		1
268	36C175A	2	CAPACITOR,FXD, CER DIEFL, 10000PF, 20%, 500V (V56289) 913-3013-000 C194		1
269	RCR32G121KS	2	RESISTOR,FXD, CMPSN, 120 OHMS, 10%, 1W (V81349) 745-3314-000 R130		1
270	RCR20G474KS	2	RESISTOR,FXD, CMPSN, 0.47MEGO, 10%, 1/2W (V81349) 745-1464-000 R60		1
271	RCR20G222KS	2	RESISTOR,FXD, CMPSN, 2.2K, 10%, 1/2W (V81349) 745-1366-000 R76		1
272	36C175A	2	CAPACITOR,FXD, CER DIEFL, 10000PF, 20%, 500V (V56289) 913-3013-000 C169		1
273	R41283-47-40	2	CAPACITOR,FXD, ELCTLT, 50UF, M20%P50%, 35V (V25088) 183-1295-540 C262		1
274	RCR20G474KS	2	RESISTOR,FXD, CMPSN, 0.47MEGO, 10%, 1/2W (V81349) 745-1464-000 R63		1
275	2DD63G104XAA	2	CAPACITOR,FXD, CER DIEFL, 1UF, M30%P80%, 75V (V71590) 913-3794-000 C312		1
275A	QC5-1UUF5PCT	2	CAPACITOR,FXD, CER DIEFL, 3.1PF, 5%, 500V (V95121) 913-2994-000 C321		AR
276	36C175A	2	CAPACITOR,FXD, CER DIEFL, 10000PF, 20%, 500V (V56289) 913-3013-000 C177		1
277	36C175A	2	CAPACITOR,FXD, CER DIEFL, 10000PF, 20%, 500V (V56289) 913-3013-000 C171		1
278	36C175A	2	CAPACITOR,FXD, CER DIEFL, 10000PF, 20%, 500V (V56289) 913-3013-000 C178		1
279	RCR20G152JS	2	RESISTOR,FXD, CMPSN, 1.5K, 5%, 1/2W (V81349) 745-1358-000 R84		1
280	R41283-47-40	2	CAPACITOR,FXD, ELCTLT, 50UF, M20%P50%, 35V (V25088) 183-1295-540 C167		1
281	RCR20G100KS	2	RESISTOR,FXD, CMPSN, 10 OHMS, 10%, 1/2W (V81349) 745-1268-000 R122		1
282	RCR20G682KS	2	RESISTOR,FXD, CMPSN, 6.8K, 10%, 1/2W (V81349) 745-1387-000 R59		1
283	RCR07G221KS	2	RESISTOR,FXD, CMPSN, 220 OHMS, 10%, 1/4W (V81349) 745-0725-000 R147		1
284	RCR20G751JS	2	RESISTOR,FXD, CMPSN, 750 OHMS, 5%, 1/2W (V81349) 745-1347-000 R83		1
285	RCR20G102KS	2	RESISTOR,FXD, CMPSN, 1K, 10%, 1/2W (V81349) 745-1352-000 R72		1
286	CM05FD331J03	2	CAPACITOR,FXD, MICA DIEFL, 330PF, 5%, 500V (V81349) 912-2852-000 C173		1
287	36C175A	2	CAPACITOR,FXD, CER DIEFL, 10000PF, 20%, 500V (V56289) 913-3013-000 C250		1
288	RCR20G104KS	2	RESISTOR,FXD, CMPSN, 0.10MEGO, 10%, 1/2W (V81349) 745-1436-000 R77		1
289	D31536	2	CAPACITOR,FXD, ELCTLT, 5UF, M10%P75%, 50V (V56289) 183-1162-000 C269		1
290	RCR20G512JS	2	RESISTOR,FXD, CMPSN, 5.1K, 5%, 1/2W (V81349) 745-1382-000 R82		1
291	RCR20G224KS	2	RESISTOR,FXD, CMPSN, 0.22MEGO, 10%, 1/2W (V81349) 745-1450-000 R78		1
292	RCR20G102KS	2	RESISTOR,FXD, CMPSN, 1K, 10%, 1/2W (V81349) 745-1352-000 R102		1
293	RCR20G470KS	2	RESISTOR,FXD, CMPSN, 47 OHMS, 10%, 1/2W (V81349) 745-1296-000 R112		1

section 6
parts list

GROUP ASSEMBLY PARTS LIST

FIG - ITEM	PART NO	INDENT	DESCRIPTION	USABLE ON CODE	UNITS PER ASSY
6-3 294	CM05C0100DC3	2	CAPACITOR,FXD, MICA DIEI, 10PF, 0.5PF, 500V (V81349) 912-2753-000 C228		1
295	557GC6C0PC39R	2	CAPACITOR,VAR, 5PF TO 25PF, 350V (V72982) 917-1194-000 C227	J,M,N	1
295	557-018-5-25A	2	CAPACITOR,VAR, CER DIEI, 5 TO 37.5PF, 350V (V72982) 917-1073-000 C227	K,L	1
296	RCR20G47CKS	2	RESISTOR,FXD, CMPSN, 47 OHMS, 10%, 1/2W (V81349) 745-1296-000 R117		1
297	RCR20G224KS	2	RESISTOR,FXD, CMPSN, 0.22MEGO, 10%, 1/2W (V81349) 745-1450-000 R101		1
298	2BDC63G104XAA	2	CAPACITOR,FXD, CER DIEI, 1UF, M30%P80%, 75V (V71590) 913-3794-000 C223		1
299	TS1C3P01	2	SOCKET,ELECTRON (V81349) 220-1103-000 XV16		1
300	TS0205C01	2	SOCKET,XTAL (V81349) 292-0082-000 XY14		1
301	TS1C2P01	2	SOCKET,ELECTRON (V81349) 220-1111-000 XV12		1
302	TS1C3P01	2	SOCKET,ELECTRON (V81349) 220-1103-000 XV14 (REPLACE WITH 220-1274-000)	J,K,L,N	1
302	TS1C3P02	2	SOCKET,ELECTRON (V81349) 220-1274-000 XV14 (REPLACES 220-1103-000)	J,K,L,N	1
302	TS1C3P01	2	SOCKET,ELECTRON (V81349) 220-1103-000 XV14	M	1
303	TS1C2P01	2	SOCKET,ELECTRON (V81349) 220-1111-000 XV13 (REPLACE WITH 220-1152-000)	J,K,L,N	1
303	TS1C2P02	2	SOCKET,ELECTRON (V81349) 220-1152-000 XV13 (REPLACES 220-1111-000)	J,K,L,N	1
303	TS1C2P01	2	SOCKET,ELECTRON (V81349) 220-1111-000 XV13	M	1
304	6H12	2	TERMINAL BOARD (V82893) 306-0909-000 TB8		1
305	6H12	2	TERMINAL BOARD (V82893) 306-0909-000 TB7		1
306	CC2CCK010D	2	CAPACITOR,FXD, CER DIEI, 1PF, 1/2PF, 500V (V81349) 916-0071-000 C232		1
307	RCR20G221JS	2	RESISTOR,FXD, CMPSN, 220 OHMS, 5%, 1/2W (V81349) 745-1323-000 R2		1
308	44C7A	2	CAPACITOR,FXD, CER DIEI, 4700PF, 20%, 500V (V56289) 913-3012-000 C4		1
309	CM05FD101G03	2	CAPACITOR,FXD, MICA DIEI, 100PF, 2%, 500V (V81349) 912-2815-000 C3		1
310	CM05ED47CJ03	2	CAPACITOR,FXD, MICA DIEI, 47PF, 5%, 500V (V81349) 912-2792-000 C39		1
311	BS217	2	COIL,RF, 220UH (V99800) 240-0198-000 L115 (REPLACE WITH 240-2524-000)		1
311	MS9C538-20	2	COIL,RF, 220UH (V96906) 240-2524-000 L115 (REPLACES 240-0198-000)		1
312	RCR07G392KS	2	RESISTOR,FXD, CMPSN, 3.9K, 10%, 1/4W (V81349) 745-0770-000 R74		1
313	1N482A	2	SEMICOND DEVICE (V07263) 353-2648-000 CR16		1
314	44C7A	2	CAPACITOR,FXD, CER DIEI, 4700PF, 20%, 500V (V56289) 913-3012-000 C70		1
315	RCR07G104KS	2	RESISTOR,FXD, CMPSN, 0.10MEGO, 10%, 1/4W (V81349) 745-0821-000 R8		1
316	19C372	2	CAPACITOR,FXD, CER DIEI, 470PF, 20%, 500V (V56289) 913-3007-000 C69		1
317	502-1427-002	2	SHIELD,SOCKET		1
318	MS9C539-15	2	COIL,RF, 1000UH (V96906) 240-2540-000 L70		1
319	36C175A	2	CAPACITOR,FXD, CER DIEI, 10000PF, 20%, 500V (V56289) 913-3013-000 C124		1
320	RCR20G330KS	2	RESISTOR,FXD, CMPSN, 33 OHMS, 10%, 1/2W (V81349) 745-1289-000 R12		1
321	CM05ED220J03	2	CAPACITOR,FXD, MICA DIEI, 22PF, 5%, 500V (V81349) 912-2768-000 C103		1
322	RCR07G224KS	2	RESISTOR,FXD, CMPSN, 0.22MEGO, 10%, 1/4W (V81349) 745-0833-000 R13		1
323	RCR07G470KS	2	RESISTOR,FXD, CMPSN, 47 OHMS, 10%, 1/4W (V81349) 745-0701-000 R137		1
324	RCR07G474KS	2	RESISTOR,FXD, CMPSN, 0.47MEGO, 10%, 1/4W (V81349) 745-0845-000 R91		1
325	CM04FD680J03	2	CAPACITOR,FXD, MICA DIEI, 68PF, 5%, 500V (V81349) 912-3867-000 C197		1

GROUP ASSEMBLY PARTS LIST

FIG - ITEM	PART NO	INDENT	DESCRIPTION	USABLE ON CODE	UNITS PER ASSY
6-3 326	RCR07G103KS	2	RESISTOR,FXD, CMPSN, 10K, 10%, 1/4W (V81349) 745-0785-000 R6		1
327	RCR20G102KS	2	RESISTOR,FXD, CMPSN, 1K, 10%, 1/2W (V81349) 745-1352-000 R94		1
328	CC20CK010C	2	CAPACITOR,FXD, CER DIEI, 1PF, 1/4PF, 500V (V81349) 916-0070-000 C104		1
329	RCR07G103KS	2	RESISTOR,FXD, CMPSN, 10K, 10%, 1/4W (V81349) 745-0785-000 R5		1
330	CC20CK010C	2	CAPACITOR,FXD, CER DIEI, 1PF, 1/4PF, 500V (V81349) 916-0070-000 C1		1
331	MS35489-4	2	GROMMET,RRR (V96906) 201-0001-000		7
332	1909	2	TERMINAL BOARD (V71785) 306-0838-000 TB13		1
333	CC20CK020C	2	CAPACITOR,FXD, CER DIEI, 2PF, 1/4PF, 500V (V81349) 916-0075-000 C111		1
334	19C372	2	CAPACITOR,FXD, CER DIEI, 470PF, 20%, 500V (V56289) 913-3007-000 C270		1
335	36C175A	2	CAPACITOR,FXD, CER DIEI, 10000PF, 20%, 500V (V56289) 913-3013-000 C106		1
336	RCR07G473KS	2	RESISTOR,FXD, CMPSN, 47K, 10%, 1/4W (V81349) 745-0809-000 R126		1
337	RCR20G102KS	2	RESISTOR,FXD, CMPSN, 1K, 10%, 1/2W (V81349) 745-1352-000 R15		1
338	40C73A1	2	CAPACITOR,FXD, CER DIEI, 1000PF, 20%, 500V (V56289) 913-3009-000 C324		1
339	1560	2	TERMINAL BOARD (V71785) 367-0944-000 TB14		1
340	RCR20G102KS	2	RESISTOR,FXD, CMPSN, 1K, 10%, 1/2W (V81349) 745-1352-000 R14		1
341	RCR32G102KS	2	RESISTOR,FXD, CMPSN, 1K, 10%, 1W (V81349) 745-3352-000 R11		1
342	40C73A1	2	CAPACITOR,FXD, CER DIEI, 1000PF, 20%, 500V (V56289) 913-3009-000 C73		1
343	36C175A	2	CAPACITOR,FXD, CER DIEI, 10000PF, 20%, 500V (V56289) 913-3013-000 C105		1
344	RCR07G101KS	2	RESISTOR,FXD, CMPSN, 100 OHMS, 10%, 1/4W (V81349) 745-0713-000 R10		1
345	RCR20G473KS	2	RESISTOR,FXD, CMPSN, 47K, 10%, 1/2W (V81349) 745-1422-000 R151		1
346	36C175A	2	CAPACITOR,FXD, CER DIEI, 10000PF, 20%, 500V (V56289) 913-3013-000 C318		1
347	4422-4-26	2	COIL,RF, 10UH (V82142) 240-0164-000 L116		1
348	36C175A	2	CAPACITOR,FXD, CER DIEI, 10000PF, 20%, 500V (V56289) 913-3013-000 C72		1
349	RCR07G106KS	2	RESISTOR,FXD, CMPSN, 10MEGO, 10%, 1/4W (V81349) 745-0893-000 R124		1
350	289-1576-00M20	2	XTAL UNIT,QTZ, 14000.00KHZ (V00136) 289-1576-000 Y16		1
351	RCR07G104KS	2	RESISTOR,FXD, CMPSN, 0.10MEGO, 10%, 1/4W (V81349) 745-0821-000 R3		1
352	36C175A	2	CAPACITOR,FXD, CER DIEI, 10000PF, 20%, 500V (V56289) 913-3013-000 C322		1
353	RCR20G221KS	2	RESISTOR,FXD, CMPSN, 220 OHMS, 10%, 1/2W (V81349) 745-1324-000 R114		1
354	MS90539-15	2	COIL,RF, 1000UH (V96906) 240-2540-000 L1		1
355	RCR07G104KS	2	RESISTOR,FXD, CMPSN, 0.10MEGO, 10%, 1/4W (V81349) 745-0821-000 R152		1
356	CM04CD100D03	2	CAPACITOR,FXD, MICA DIEI, 10PF, 0.5PF, 500V (V81349) 912-3837-000 C306		1
357	36C175A	2	CAPACITOR,FXD, CER DIEI, 10000PF, 20%, 500V (V56289) 913-3013-000 C263 (REPLACE WITH 913-3009-000)		1
357	40C73A1	2	CAPACITOR,FXD, CER DIEI, 1000PF, 20%, 500V (V56289) 913-3009-000 C263 (REPLACES 913-3013-000)		1
358	557006C0P039R	2	CAPACITOR,VAR, 5PF TO 25PF, 350V (V72982) 917-1194-000 C2	J,M,N	1
358	557-018-5-25A	2	CAPACITOR,VAR, CER DIEI, 5 TO 37.5PF, 350V (V72982) 917-1073-000 C2	K,L	1

section 6
parts list

GROUP ASSEMBLY PARTS LIST

FIG - ITEM	PART NO	INDENT	DESCRIPTION	USABLE ON CODE	UNITS PER ASSY
6-3 359	TS103P01	2	SOCKET,ELECTRON (V81349) 220-1103-000 XV10		1
360	TS102P01	2	SOCKET,ELECTRON (V81349) 220-1111-000 XV1		1
361	TS103P01	2	SOCKET,ELECTRON (V81349) 220-1103-000 XV2		1
362	1520A	2	TERMINAL BOARD (V71785) 306-9033-000 TB15		1
363	RCR07G104KS	2	RESISTOR,FXD, CMPSN, 0.10MEGO, 10%, 1/4W (V81349) 745-0821-000 R103		1
364	CM05ED200J03	2	CAPACITOR,FXD, MICA DIEI, 20PF, 5%, 500V (V81349) 912-2765-000 C196		1
365	RCR20G330KS	2	RESISTOR,FXD, CMPSN, 33 OHMS, 10%, 1/2W (V81349) 745-1289-000 R17		1
366	CM05CD100D03	2	CAPACITOR,FXD, MICA DIEI, 10PF, 0.5PF, 500V (V81349) 912-2753-000 C234		1
367	RCR20G473KS	2	RESISTOR,FXD, CMPSN, 47K, 10%, 1/2W (V81349) 745-1422-000 R116		1
368	36C175A	2	CAPACITOR,FXD, CER DIEI, 10000PF, 20%, 500V (V56289) 913-3013-000 C170		1
369	CM05ED470J03	2	CAPACITOR,FXD, MICA DIEI, 47PF, 5%, 500V (V81349) 912-2792-000 C237		1
370	X188-1	2	TRANSFORMER,RF (V81815) 278-0541-000 T11		1
371	RCR07G101KS	2	RESISTOR,FXD, CMPSN, 100 OHMS, 10%, 1/4W (V81349) 745-0713-000 R139		1
372	44C7A	2	CAPACITOR,FXD, CER DIEI, 4700PF, 20%, 500V (V56289) 913-3012-000 C236		1
373	RCR07G102KS	2	RESISTOR,FXD, CMPSN, 1K, 10%, 1/4W (V81349) 745-0749-000 R104		1
374	RCR07G102KS	2	RESISTOR,FXD, CMPSN, 1K, 10%, 1/4W (V81349) 745-0749-000 R18		1
375	DM15F101K500WV4C R	2	CAPACITOR,FXD, MICA DIEI, 100PF, 10%, 500V (V72136) 912-2817-000 C235		1
376	44C7A	2	CAPACITOR,FXD, CER DIEI, 4700PF, 20%, 500V (V56289) 913-3012-000 C112		1
377	RS217	2	COIL,RF, 220UH (V99800) 240-0198-000 L113 (REPLACE WITH 240-2524-000)		1
377	MS90538-20	2	COIL,RF, 220UH (V96906) 240-2524-000 L113 (REPLACES 240-0198-000)		1
378	332-1403-165	2	TERMINAL BOARD (V71785) 306-0001-000 TB16		1
379	TS0205C01	2	SOCKET,XTAL (V81349) 292-0082-000 XY17		1
380	557006C0P039R	2	CAPACITOR,VAR, 5PF TO 25PF, 350V (V72982) 917-1194-000 C233		1
381	TS103P01	2	SOCKET,ELECTRON (V81349) 220-1103-000 XV3		1
382	18-257	2	COIL,RF, 10MH (V09250) 240-0199-000 L105		1
383	36C175A	2	CAPACITOR,FXD, CER DIEI, 10000PF, 20%, 500V (V56289) 913-3013-000 C122		1
384	RCR20G102KS	2	RESISTOR,FXD, CMPSN, 1K, 10%, 1/2W (V81349) 745-1352-000 R21		1
384A	MS21266-1N	2	PLASTIC CHANNEL (V96906) 150-0173-000		AR
385	4422-4-26	2	COIL,RF, 10UH (V82142) 240-0164-000 L118		1
386	RCR20G474KS	2	RESISTOR,FXD, CMPSN, 0.47MEGO, 10%, 1/2W (V81349) 745-1464-000 R89		1
387	RCR20G472KS	2	RESISTOR,FXD, CMPSN, 4.7K, 10%, 1/2W (V81349) 745-1380-000 R90		1
388	36C175A	2	CAPACITOR,FXD, CER DIEI, 10000PF, 20%, 500V (V56289) 913-3013-000 C255 (REPLACE WITH 913-2142-000)		1
388	33C2	2	CAPACITOR,FXD, CER DIEI, 0.02UF, 20%, 500V (V56289) 913-2142-000 C255 (REPLACES 913-3013-000)		1
389	41C92	2	CAPACITOR,FXD, CER DIEI, 0.1UF, M20%P80%, 500V (V56289) 913-3152-000 C193		1
390	36C175A	2	CAPACITOR,FXD, CER DIEI, 10000PF, 20%, 500V (V56289) 913-3013-000 C251		1
391	RCR20G330KS	2	RESISTOR,FXD, CMPSN, 33 OHMS, 10%, 1/2W (V81349) 745-1289-000 R20		1
392	RCR20G123KS	2	RESISTOR,FXD, CMPSN, 12K, 10%, 1/2W (V81349) 745-1398-000 R138		1
393	841-00GX5V0223Z	2	CAPACITOR,FXD, CER DIEI, 22000PF, M20%P100%, 500V (V72982) 913-3014-000 C254		1

GROUP ASSEMBLY PARTS LIST

FIG - ITEM	PART NO	INDENT	DESCRIPTION	USABLE ON CODE	UNITS PER ASSY
6-3 394	36C175A	2	CAPACITOR,FXD, CER DIEI, 1000PF, 20%, 500V (V56289) 913-3013-000 C123		1
395	40C73A1	2	CAPACITOR,FXD, CER DIEI, 1000PF, 20%, 500V (V56289) 913-3009-000 C125		1
396	4422-4-26	2	COIL,RF, 10UH (V82142) 240-0164-000 L117		1
397	RCR20G102KS	2	RESISTOR,FXD, CMPSN, 1K, 10%, 1/2W (V81349) 745-1352-000 R22		1
398	DM15F471J300WV4C R	2	CAPACITOR,FXD, MICA DIEI, 470PF, 5%, 500V (V72136) 912-2864-000 C266		1
399	B9217	2	COIL,RF, 220UH (V99800) 240-0198-000 L121		1
400	XAT957	2	JACK,TEL (V82389) 360-0194-000 J6		1
401	TS103P01	2	SOCKET,ELECTRON (V81349) 220-1103-000 XV4		1
402	6H12	2	TERMINAL BOARD (V82893) 306-0909-000 TB11		1
403	281-0330-000	2	KNOR (V18986) 281-0330-000		1
404	756-2335-002	2	SHIELD		1
405	543-8039-000	2	KNOP		3
406	547-2673-000	2	PANEL ASSY, FRONT	J,M,N	1
407	280-3421-00	3	INSIGNIA (VA1334) 280-3421-000		1
408	163003-0100	3	AMMETER,DC (V38315) 458-0589-000 M1		1
409	RCR20G331KS	3	RESISTOR,FXD, CMPSN, 330 OHMS, 10%, 1/2W (V81349) 745-1331-000 R87		1
410	RCR20G473KS	3	RESISTOR,FXD, CMPSN, 47K, 10%, 1/2W (V81349) 745-1422-000 R88		1
411	210878K1AC	3	SWITCH,RTRY (V76854) 259-1336-000 S1		1
412	RCR20G123KS	3	RESISTOR,FXD, CMPSN, 12K, 10%, 1/2W (V81349) 745-1398-000 R142		1
413	LW9778	3	RESISTOR,VAR, 100K, 20%, 1/4W (V71450) 376-7410-000 R141 ,S7		1
414	1N270	3	SEMICOND DEVICE (V08257) 353-2018-000 CR5		1
415	RCR07G472KS	3	RESISTOR,FXD, CMPSN, 4.7K, 10%, 1/4W (V81349) 745-0773-000 R111		1
416	1N270	3	SEMICOND DEVICE (V08257) 353-2018-000 CR18		1
417	1N270	3	SEMICOND DEVICE (V08257) 353-2018-000 CR20		1
418	1N270	3	SEMICOND DEVICE (V08257) 353-2018-000 CR19		1
419	RN5504221F	3	RESISTOR,FXD, FILM, 4.22K, 1%, 1/8W (V81349) 705-1026-000 R64		1
420	RN5501782F	3	RESISTOR,FXD, FILM, 17.8K, 1%, 1/8W (V81349) 705-1056-000 R8C		1
421	841283-47-40	3	CAPACITOR,FXD, ELCTLT, 50UF, M20X50%, 35V (V25088) 183-1295-540 C253		1
422	211952-187K1	3	SWITCH,RTRY (V76854) 259-1358-000 S3		1
423	547-2744-004	3	PLATE, ESCUTCHEON		1
424	547-2743-003	3	LENS,INDICATOR		1
425	757-8614-001	3	ARM LOCK		1
426	757-8613-001	3	BUSHING		1
427	757-8610-001	3	SPRING		1
428	540-9181-003	3	POST		1
429	376-7676-020	3	RESISTOR,VAR, CMPSN, 25K, 30%, 500W 376-7676-020 RR6		1
430	210430F1	3	SWITCH,RTRY (V76854) 259-1337-000 S2C		1
431	13E	3	JACK,TEL (V82389) 360-0136-000 J16		1
432	TR8169	3	RESISTOR,VAR, 500K, 20%, 1/4W, 2 SECT (V71450) 376-2477-000 R57 ,R75		1
433	547-2637-002	2	BAR, SUPPORT-CHASSIS		1
434	609-1067-001	2	DRIVE,DIAL		1
435	547-2634-002	2	CONNECTING LINK RIGID		1
436	547-2635-002	2	PIVOT		2
437	547-2643-002	2	WINDOW,DIAL		1
438	CM05FD101J03	2	CAPACITOR,FXD, MICA DIEI, 100PF, 5%, 500V (V81349) 912-2816-000 C327		1
439	547-2728-004	2	CHASSIS		1

GROUP ASSEMBLY PARTS LIST

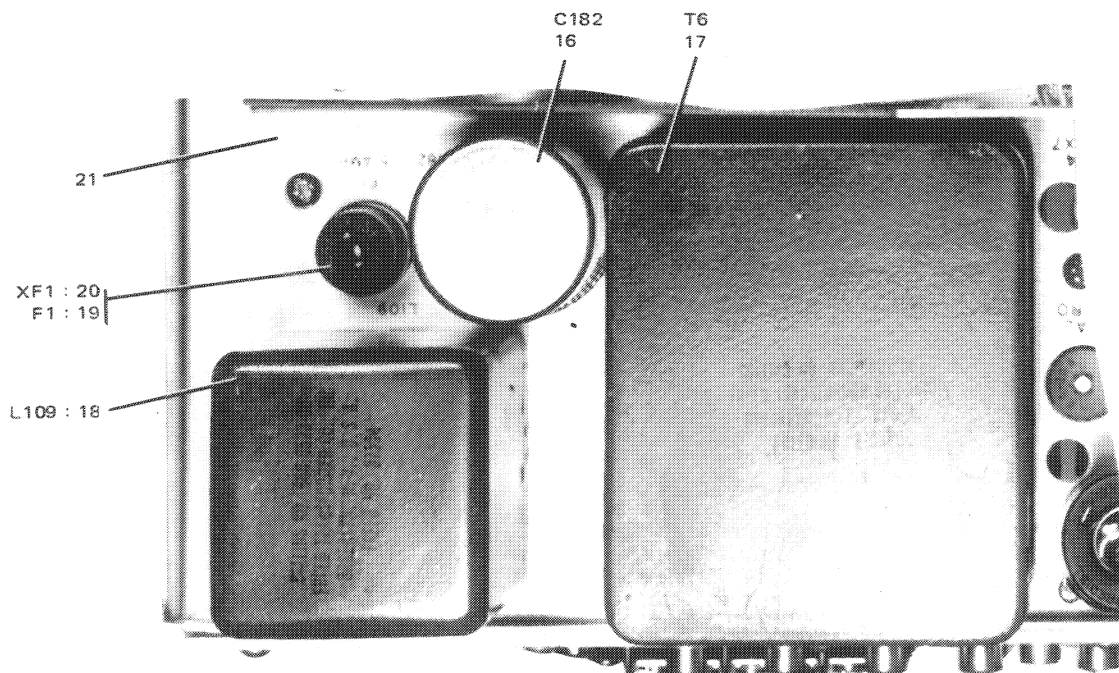
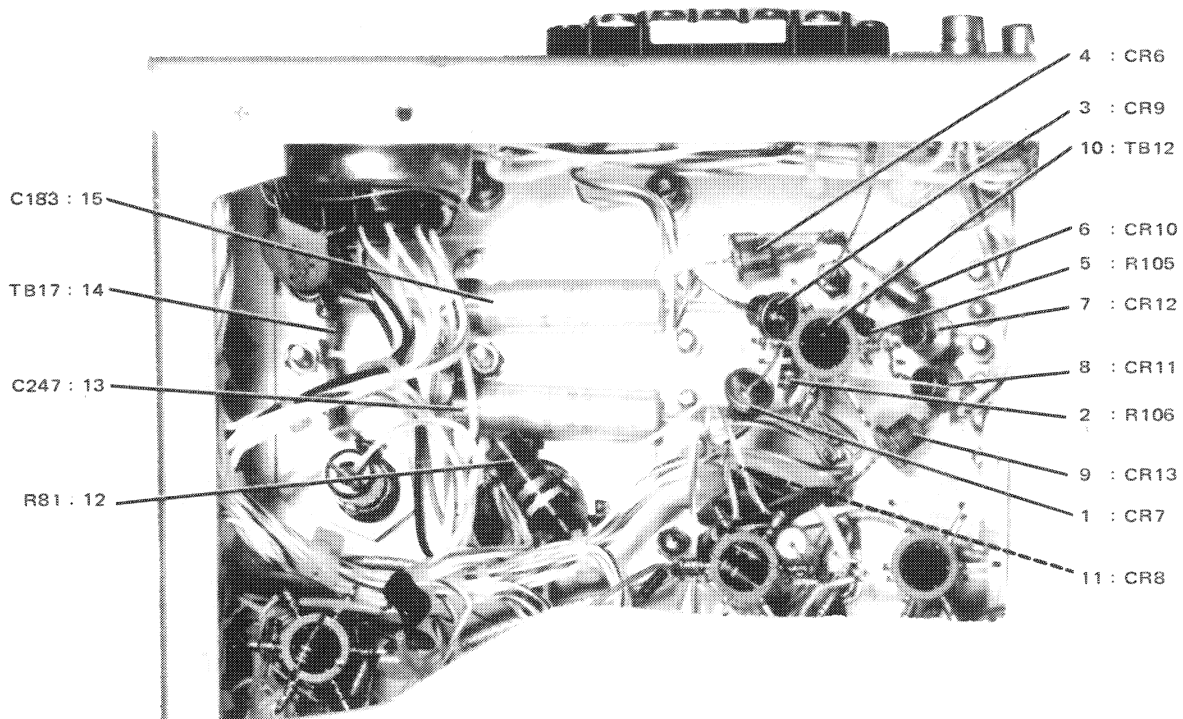

TP3 8406-017

Power Supply
Figure 6-4

GROUP ASSEMBLY PARTS LIST

FIG - ITEM	PART NO	INDENT	DESCRIPTION	USABLE ON CODE	UNITS PER ASSY
6-4 -	547-2693-000	1	POWER SUPPLY (SEE FIG 6-3-34 FOR NHA)	J,M,N	REF
1	1N1695	2	SEMICOND DEVICE (V81483) 353-1665-000 CR7		1
2	RGR20G102KS	2	RESISTOR,FXD, CMPSN, 1K, 10%, 1/2W (V81349) 745-1352-000 R106		1
3	1N1695	2	SEMICOND DEVICE (V81483) 353-1665-000 CR9		1
4	1N1695	2	SEMICOND DEVICE (V81483) 353-1665-000 CR6		1
5	RGR20G102KS	2	RESISTOR,FXD, CMPSN, 1K, 10%, 1/2W (V81349) 745-1352-000 R105		1
6	1N1695	2	SEMICOND DEVICE (V81483) 353-1665-000 CR10		1
7	1N1695	2	SEMICOND DEVICE (V81483) 353-1665-000 CR12		1
8	1N1695	2	SEMICOND DEVICE (V81483) 353-1665-000 CR11		1
9	1N1695	2	SEMICOND DEVICE (V81483) 353-1665-000 CR13		1
10	6H12	2	TERMINAL BOARD (V82893) 306-0909-000 TB12		1
11	1N1695	2	SEMICOND DEVICE (V81483) 353-1665-000 CR8		1
12	RGR42G102KS	2	RESISTOR,FXD, CMPSN, 1K, 10%, 2W (V81349) 745-5652-000 R81		1
13	D29238	2	CAPACITOR,FXD, ELCTLT, 50UF, M10XP75%, 50V (V56289) 183-1170-000 C247		1
14	152CA	2	TERMINAL BOARD (V71785) 306-9033-000 TB17		1
15	D29238	2	CAPACITOR,FXD, ELCTLT, 50UF, M10XP75%, 50V (V56289) 183-1170-000 C183		1
16	D33257	2	CAPACITOR,FXD, ELCTLT, 40UF, M10XP100%, 200V, 3 SECT (V56289) 183-1763-000 C182		1
17	37558	2	TRANSFORMER,PWR (V73386) 662-0002-000 T6		1
18	37554	2	REACTOR, 2.5H (V73386) 668-0523-000 L109		1
19	F02R250V1 1-2AS	2	FUSE,CRTG (V81349) 264-0007-000 F1		1
20	HKPHJRZZ	2	FUSEHOLDER (V71400) 265-1019-000 XF1		1
21	756-3002-004	2	CHASSIS,PLATE		1

GROUP ASSEMBLY PARTS LIST

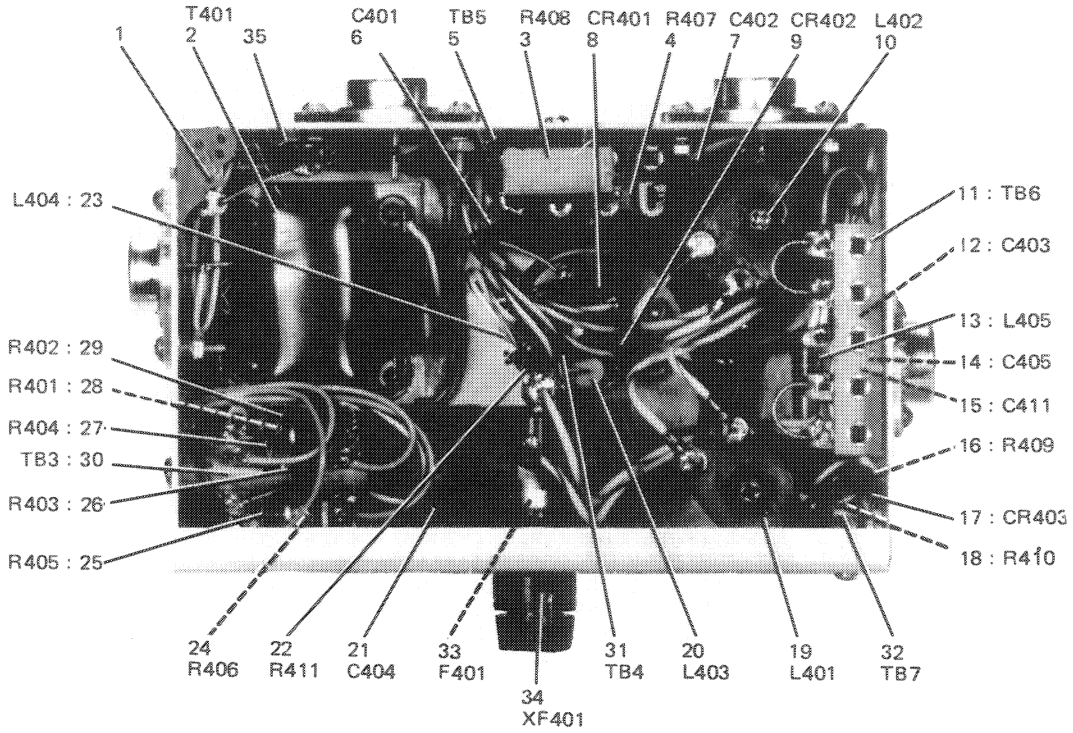

TOP VIEW

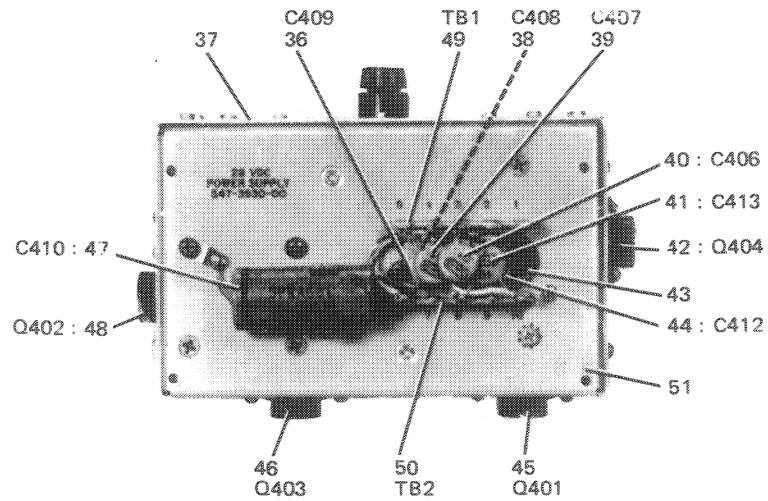

BOTTOM VIEW

TP3-8405-017

GROUP ASSEMBLY PARTS LIST

FIG - ITEM	PART NO	INDENT	DESCRIPTION	USABLE ON CODE	UNITS PER ASSY
6-5 -	547-3930-000	1	POWER SUPPLY, 28-VDC (SEE FIG 6-3-34 FOR NHA)	K,L	REF
1	549-0216-003	2	COVER		1
2	664-1020-000	2	TRANSFORMER,PWR 664-1023-000 T401		1
3	PW5-1000-10	2	RESISTOR,FXD,WW 100 OHMS, 10%, 5W (V07716) 710-9109-000 R408		1
4	PW5-1000-10	2	RESISTOR,FXD,WW 100 OHMS, 10%, 5W (V07716) 710-9109-000 R407		1
5	1532A	2	TERMINAL BOARD (V71785) 306-9032-000 TB5		1
6	D27276	2	CAPACITOR,FXD, ELCTLT, 150UF, M10%P100%, 50V (V56289) 183-1307-000 C401		1
7	33C2	2	CAPACITOR,FXD, CER DIEL, 0.02UF, 20%, 500V (V56289) 913-2142-000 C402		1
8	1N1695	2	SEMICOND DEVICE (V81483) 353-1665-000 CR401		1
9	1N1695	2	SEMICOND DEVICE (V81483) 353-1665-000 CR402		1
10	C800	2	COIL,RF (V95265) 240-0021-000 L402		1
11	1542A	2	TERMINAL BOARD (V71785) 306-0550-000 TB6		1
12	33C2	2	CAPACITOR,FXD, CER DIEL, 0.02UF, 20%, 500V (V56289) 913-2142-000 C403		1
13	240-0194-000	2	COIL,RF, 120UH (V82142) 240-0194-000 L405 (EFF TO REV LTR F)		1
13	MS75103-10	2	COIL,RF, 120UH (V96906) 240-1627-000 L405 (EFF REV LTR F)		1
14	D27950	2	CAPACITOR,FXD, ELCTLT, 35UF, M10%P100%, 50V (V56289) 183-1381-000 C405		1
15	D27950	2	CAPACITOR,FXD, ELCTLT, 35UF, M10%P100%, 50V (V56289) 183-1381-000 C411		1
16	RCR20G102KS	2	RESISTOR,FXD, CMPSN, 1K, 10%, 1/2W (V81349) 745-1352-000 R409		1
17	1N1693	2	SEMICOND DEVICE (V81483) 353-1663-000 CR403		1
18	RCR20G102KS	2	RESISTOR,FXD, CMPSN, 1K, 10%, 1/2W (V81349) 745-1352-000 R410		1
19	C800	2	COIL,RF (V95265) 240-0021-000 L401		1
20	240-0194-000	2	COIL,RF, 120UH (V82142) 240-0194-000 L403 (EFF TO REV LTR F)		1
20	MS75103-10	2	COIL,RF, 120UH (V96906) 240-1627-000 L403		1
21	D36523	2	CAPACITOR,FXD, ELCTLT, 40UF, M10%P100%, 250V, 3 SECT (V56289) 183-0723-000 C404		1
22	RCR32G102KS	2	RESISTOR,FXD, CMPSN, 1K, 10%, 1W (V81349) 745-3352-000 R411		1
23	240-0194-000	2	COIL,RF, 120UH (V82142) 240-0194-000 L404 (EFF TO REV LTR F)		1
23	MS75103-10	2	COIL,RF, 120UH (V96906) 240-1627-000 L404 (EFF REV LTR F)		1
24	RCR20G151KS	2	RESISTOR,FXD, CMPSN, 150 OHMS, 10%, 1/2W (V81349) 745-1317-000 R406		1
25	RCR32G472KS	2	RESISTOR,FXD, CMPSN, 4.7K, 10%, 1W (V81349) 745-3380-000 R405		1
26	RCR20G151KS	2	RESISTOR,FXD, CMPSN, 150 OHMS, 10%, 1/2W (V81349) 745-1317-000 R403		1
27	RCR32G472KS	2	RESISTOR,FXD, CMPSN, 4.7K, 10%, 1W (V81349) 745-3380-000 R404		1
28	RCR20G151KS	2	RESISTOR,FXD, CMPSN, 150 OHMS, 10%, 1/2W (V81349) 745-1317-000 R401		1
29	RCR32G472KS	2	RESISTOR,FXD, CMPSN, 4.7K, 10%, 1W (V81349) 745-3380-000 R402		1
30	6H12	2	TERMINAL BOARD (V82893) 306-0909-000 TB3		1
31	6H12	2	TERMINAL BOARD (V82893) 306-0909-000 TB4		1
32	1542A	2	TERMINAL BOARD (V71785) 306-0550-000 TB7		1
33	F02A250V6AS	2	FUSE,CRTG (V81349) 264-4100-000 F401		1
34	HKPHJRZZ	2	FUSEHOLDER (V71400) 265-1019-000 XF401		1

section 6
parts list

GROUP ASSEMBLY PARTS LIST

FIG - ITEM	PART NO	INDENT	DESCRIPTION	USABLE ON CODE	UNITS PER ASSY
6-5	35	549-0312-000	2 WIRING HARNESS		1
	36	36C175A	2 CAPACITOR,FXD, CER DIEL, 10000PF, 20%, 500V (V56289) 913-3013-000 C409		1
	37	549-0217-003	2 PLATE,FRONT		1
	38	36C175A	2 CAPACITOR,FXD, CER DIEL, 10000PF, 20%, 500V (V56289) 913-3013-000 C408		1
	39	36C175A	2 CAPACITOR,FXD, CER DIEL, 10000PF, 20%, 500V (V56289) 913-3013-000 C407		1
	40	36C175A	2 CAPACITOR,FXD, CER DIEL, 10000PF, 20%, 500V (V56289) 913-3013-000 C406		1
	41	36C175A	2 CAPACITOR,FXD, CER DIEL, 10000PF, 20%, 500V (V56289) 913-3013-000 C413		1
	42	2N637B	2 TRANSISTOR (V04713) 352-0203-000 Q404		1
	43	911	2 GROMMET,RRR (V75543) 201-1080-000		1
	44	36C175A	2 CAPACITOR,FXD, CER DIEL, 10000PF, 20%, 500V (V56289) 913-3013-000 C412		1
	45	2N637B	2 TRANSISTOR (V04713) 352-0203-000 Q401		1
	46	2N637B	2 TRANSISTOR (V04713) 352-0203-000 Q403		1
	47	027276	2 CAPACITOR,FXD, ELCTLT, 150UF, M10%P100%, 50V (V56289) 183-1307-000 C410		1
	48	2N637B	2 TRANSISTOR (V04713) 352-0203-000 Q402		1
	49	1542A	2 TERMINAL BOARD (V71785) 306-0550-000 TB1		1
	50	1542A	2 TERMINAL BOARD (V71785) 306-0550-000 TB2		1
	51	553-9532-000	2 CHASSIS		1

GROUP ASSEMBLY PARTS LIST

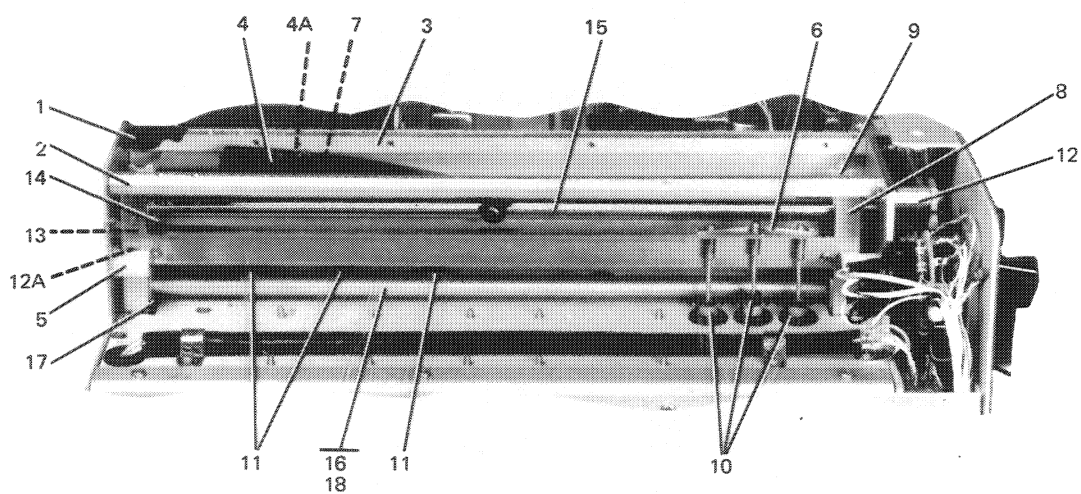

TP3-8408-037

RF Tuning Unit
Figure 6-6 (Sheet 1 of 3)

GROUP ASSEMBLY PARTS LIST

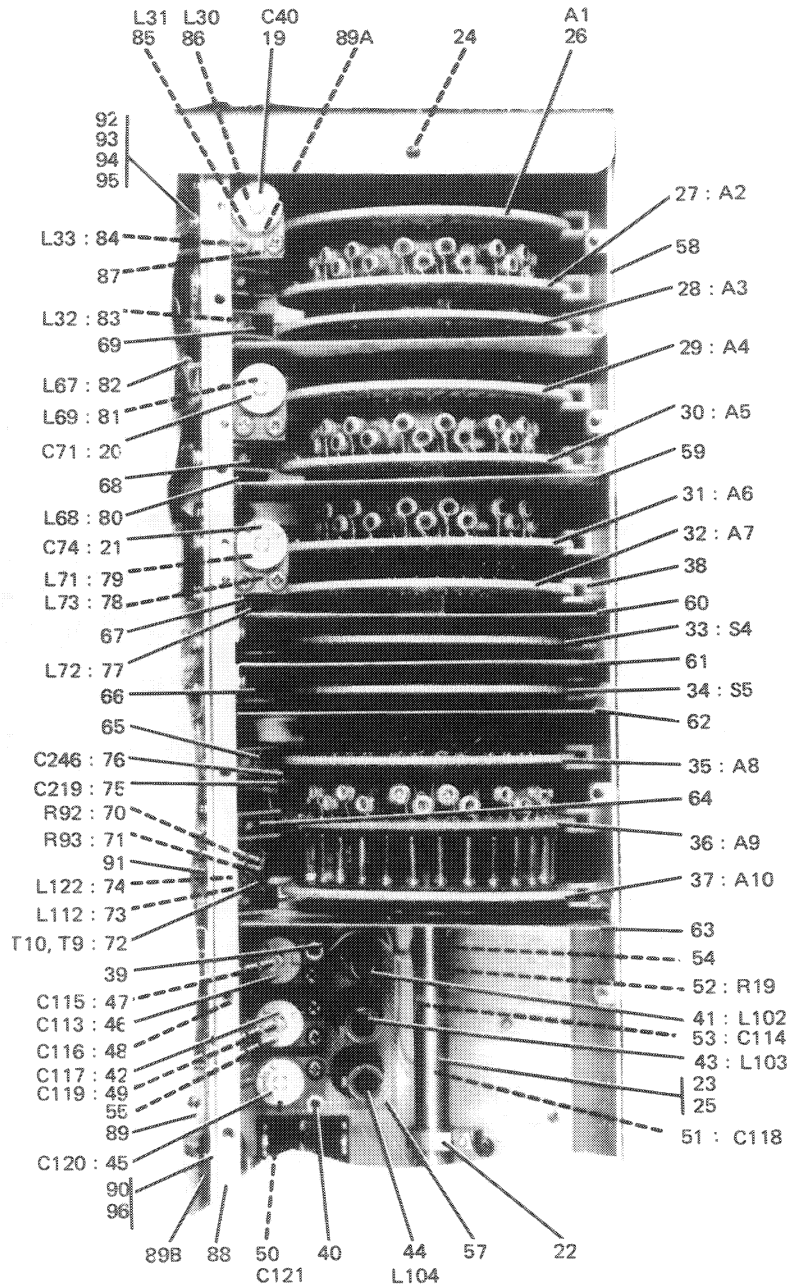

TP3-8408-037

RF Tuning Unit
Figure 6-6 (Sheet 2)

GROUP ASSEMBLY PARTS LIST

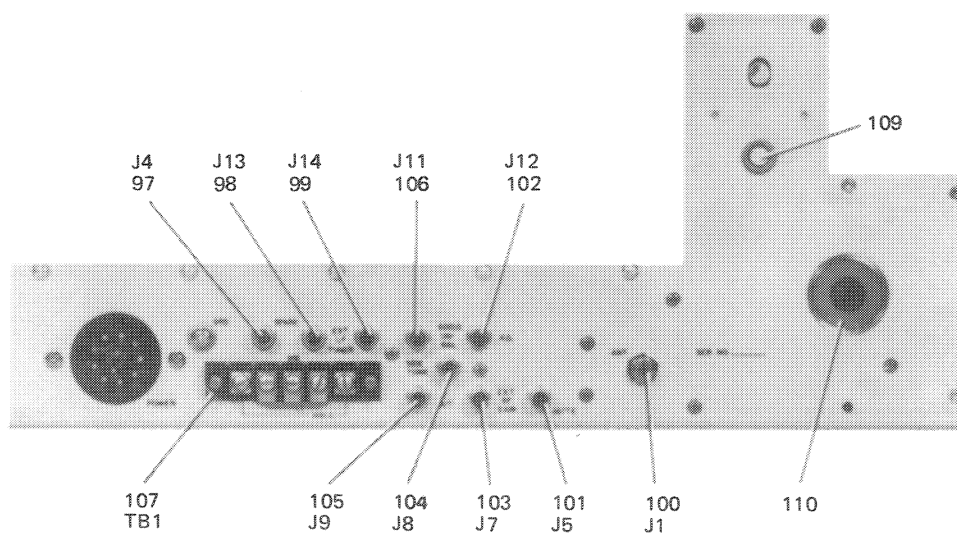

TP3-8408-037

*RF Tuning Unit
Figure 6-6 (Sheet 3)*

section 6
parts list

GROUP ASSEMBLY PARTS LIST

FIG - ITEM	PART NO	INDENT	DESCRIPTION	USABLE ON CODE	UNITS PER ASSY
6-6 -	547-2692-000	1	TUNING UNIT,RF (SEE FIG 6-3-72B FOR NHA)		REF
1	547-2603-003	2	HOUSING,SLUG RACK		1
2	547-2811-002	2	BAR,SUPPORT RACK		1
3	547-2565-002	2	BAR,SUPPORT RACK		1
4	547-2529-002	2	SPRING,TENSION		1
4A	547-2566-002	2	LEAF SPRING		1
5	756-0480-001	2	BEARING, MODIFIED		2
6	547-2528-002	2	SPRING,SLUG		1
7	547-2527-002	2	SPRING,SLUG		1
8	547-2604-003	2	TABLE,SLUG-IF		1
9	547-2605-003	2	TABLE,SLUG-RF		1
10	288-2523-000	2	CORE,PWD IRON (V92054) 288-2523-000		3
11	57-634-7	2	CORE,ADJ TUN (V78488) 288-0084-000		3
12	547-2694-005	2	GEAR TRAIN ASSY (SEE FIG 6-7)		1
12A	547-2526-002	2	PLATE,NUT		4
13	547-2525-002	2	BAND,SLUGRACK		2
14	547-2594-002	2	PULLEY,IDLER		2
15	547-2523-002	2	SHAFT,STRAIGHT		1
16	547-2626-003	2	SHAFT,DRIVER		1
17	547-2521-002	3	PULLEY,SLUG		2
18	547-2524-002	3	SHAFT,DRIVER		1
19	557-018-3-12A	2	CAPACITOR,VAR, CER DIEL, 3 TO 18PF, 350V (V72982) 917-1072-000 C40		1
20	557006COP039R	2	CAPACITOR,VAR, 5PF TO 25PF, 350V (V72982) 917-1194-000 C71		1
21	557006COP039R	2	CAPACITOR,VAR, 5PF TO 25PF, 350V (V72982) 917-1194-000 C74		1
22	504-7576-002	2	CLAMP,GEAR		1
23	547-2586-002	2	SHAFT,SHOULDER		1
24	547-2530-002	3	COLLAR-SHAFT		1
25	606-9740-000	3	SHAFT		1
26	547-2680-004	2	CAPACITOR ASSY A1 (SEE FIG 6-8)		1
27	547-2685-004	2	COIL ASSY A2 (SEE FIG 6-9)		1
28	547-2682-004	2	COUPLING ASSY A3 (SEE FIG 6-10)		1
29	547-2680-004	2	CAPACITOR ASSY A4 (SEE FIG 6-8)		1
30	547-2685-004	2	COIL ASSY A5 (SEE FIG 6-9)		1
31	547-2685-004	2	COIL ASSY A6 (SEE FIG 6-9)		1
32	549-0630-004	2	CAPACITOR ASSY, RF AMPLIFIER A7 (SEE FIG 6-11)		1
33	547-2661-004	2	DISC,SWITCHING S4		1
34	547-2661-004	2	DISC,SWITCHING S5		1
35	547-2681-004	2	CAPACITOR ASSY, CRYSTAL OSCILATOR A8 (SEE FIG 6-12)		1
36	547-2691-004	2	CAPACITOR ASSY, TRIMMER A9 (SEE FIG 6-13)		1
37	547-2677-004	2	CRYSTAL ASSY A10 (SEE FIG 6-14)		1
38	547-2580-002	2	CHANNEL,GUIDE		12
39	547-2621-003	2	COVER,VIF		1
40	540-9045-003	2	POST		2
41	547-2624-003	2	COIL L102		1
42	557006U2P034R	2	CAPACITOR,VAR, 8 TO 50PF, 350V (V72982) 917-1196-000 C117		1
43	547-2624-003	2	COIL L103		1
44	547-2624-003	2	COIL L104		1
45	557006U2P034R	2	CAPACITOR,VAR, 8 TO 50PF, 350V (V72982) 917-1196-000 C120		1
46	557006U2P034R	2	CAPACITOR,VAR, 8 TO 50PF, 350V (V72982) 917-1196-000 C113		1
47	CM05FD361G03	2	CAPACITOR,FXD, MICA DIEL, 360PF, 2%, 500V (V81349) 912-2854-000 C115		1
48	CM05CD100D03	2	CAPACITOR,FXD, MICA DIEL, 10PF, 0.5PF, 500V (V81349) 912-2753-000 C116		1
49	CM05CD050D03	2	CAPACITOR,FXD, MICA DIEL, 5PF, 0.5PF, 500V (V81349) 912-2750-000 C119		1

GROUP ASSEMBLY PARTS LIST

FIG - ITEM	PART NO	INDENT	DESCRIPTION	USABLE ON CODE	UNITS PER ASSY
6-6 50	CM05FD391G03	2	CAPACITOR,FXD, MICA DIEL, 390PF, 2%, 500V (V81349) 912-2857-000 C121		1
51	CM05FD391G03	2	CAPACITOR,FXD, MICA DIEL, 390PF, 2%, 500V (V81349) 912-2857-000 C118		1
52	RCR20G102KS	2	RESISTOR,FXD, CMPSN, 1K, 10%, 1/2W (V81349) 745-1352-000 R19		1
53	36C175A	2	CAPACITOR,FXD, CER DIEL, 10000PF, 20%, 500V (V56289) 913-3013-000 C114		1
54	152CA	2	TERMINAL BOARD (V71785) 306-9033-000		1
55	013-5700-000599	2	TERMINAL,STUD (V98291) 306-1C18-000		5
56	540-9053-003	2	POST		6
57	547-2589-002	2	STRIP,GROUNDING		1
58	547-2651-003	2	SIDE,TURRET		1
59	547-2717-003	2	PLATE,SHIELD		1
60	547-2620-003	2	PLATE,SHIELD		1
61	547-2612-003	2	PLATE,SHIELD		1
62	547-2613-003	2	PLATE,SHIELD		2
63	547-2611-003	2	PLATE,SHIELD		1
64	547-2724-003	2	CONTACT ASSY		1
65	547-2747-003	2	CONTACT ASSY		1
66	547-2749-003	2	CONTACT ASSY		2
67	547-2748-003	2	CONTACT ASSY		3
68	547-2716-003	2	CONTACT ASSY		3
69	547-2750-003	2	CONTACT ASSY		2
70	RCRC7G122KS	2	RESISTOR,FXD, CMPSN, 1.2K, 10%, 1/4W (V81349) 745-0752-000 R92		1
71	RCRC7G562KS	2	RESISTOR,FXD, CMPSN, 5.6K, 10%, 1/4W (V81349) 745-0776-000 R93		1
72	X189-2	2	TRANSFORMER,RF (V81815) 278-0542-000 T9 ,T10		1
73	MS90539-15	2	COIL,RF, 1000UH (V96906) 240-2540-000 L112		1
74	MS75008-35	2	COIL,RF, 3.9UH (V96906) 240-0144-000 L122		1
75	36C175A	2	CAPACITOR,FXD, CER DIEL, 10000PF, 20%, 500V (V56289) 913-3013-000 C219		1
76	557006C0P039R	2	CAPACITOR,VAR, 5PF TO 25PF, 350V (V72982) 917-1194-000 C246		1
77	547-2625-003	2	COIL,RF L72		1
78	MS18130-8	2	COIL,RF, 1UH (V96906) 240-1568-000 L73		1
79	MS18130-8	2	COIL,RF, 1UH (V96906) 240-1568-000 L71		1
80	547-2625-003	2	COIL,RF L68		1
81	MS18130-8	2	COIL,RF, 1UH (V96906) 240-1568-000 L69		1
82	MS18130-9	2	COIL,RF, 1.20UH (V96906) 240-0786-000 L67		1
83	547-2625-003	2	COIL,RF L32		1
84	MS18130-8	2	COIL,RF, 1UH (V96906) 240-1568-000 L33		1
85	MS18130-9	2	COIL,RF, 1.20UH (V96906) 240-0786-000 L31		1
86	546-7109-003	2	COIL,RF L30		1
87	547-2644-002	2	RETAINER, CAPACITOR		3
88	547-2614-003	2	BAR,TAPPED		1
89	547-2564-002	2	BAR,TAPPED		1
89A	RTMT12M	2	TERMINAL,STUD (V91663) 306-0976-000		3
89B	905	2	GROMMET,RBR (V75543) 201-1060-000		8
90	548-1410-000	2	COVER,TURRET		1
91	G2522	3	TERMINAL,FEEDTH (V21242) 306-0323-000		1
92	C13388SS010	3	PUSH ON NUT (V78553) 334-1331-000		24
93	548-8200-002	3	WASHER,SPRING		24
94	500-1128-003	3	WASHER		24
95	330-3029-000	3	SCREW,CAP,SCH, SST, 3-56 X 5/16 (V08664) 330-3029-000		24
96	547-2664-004	3	COVER		1
97	3501FP	2	PHONO-JACK (V82389) 360-0148-000 J4		1
98	3501FP	2	PHONO-JACK (V82389) 360-0148-000 J13		1
99	3501FP	2	PHONO-JACK (V82389) 360-0148-000 J14		1
100	3505F	2	JACK,TEL (V82389) 360-0195-000 J1		1
101	3501FP	2	PHONO-JACK (V82389) 360-0148-000 J5		1

section 6
parts list

GROUP ASSEMBLY PARTS LIST

FIG - ITEM	PART NO	INDENT	DESCRIPTION	USABLE ON CODE	UNITS PER ASSY
6-6	102	3501FP	2 PHONO-JACK (V82389) 360-0148-000 J12		1
	103	3501FP	2 PHONO-JACK (V82389) 360-0148-000 J7		1
	104	3501FP	2 PHONO-JACK (V82389) 360-0148-000 J8		1
	105	3501FP	2 PHONO-JACK (V82389) 360-0148-000 J9		1
	106	3501FP	2 PHONO-JACK (V82389) 360-0148-000 J11		1
	107	599-2004-5	2 TERMINAL BOARD (V75382) 367-7343-000 TB1 (EFF TO REV LTR AU)		1
	107	599C2004-5	2 TERMINAL BOARD (V75382) 367-7321-000 TB1 (EFF REV LTR AU)		1
	108	547-2684-004	2 PLATE, REAR		1
	109	547-3739-002	3 BEARING, SLEEVE		1
	110	547-2531-002	3 BEARING, TURRET		1

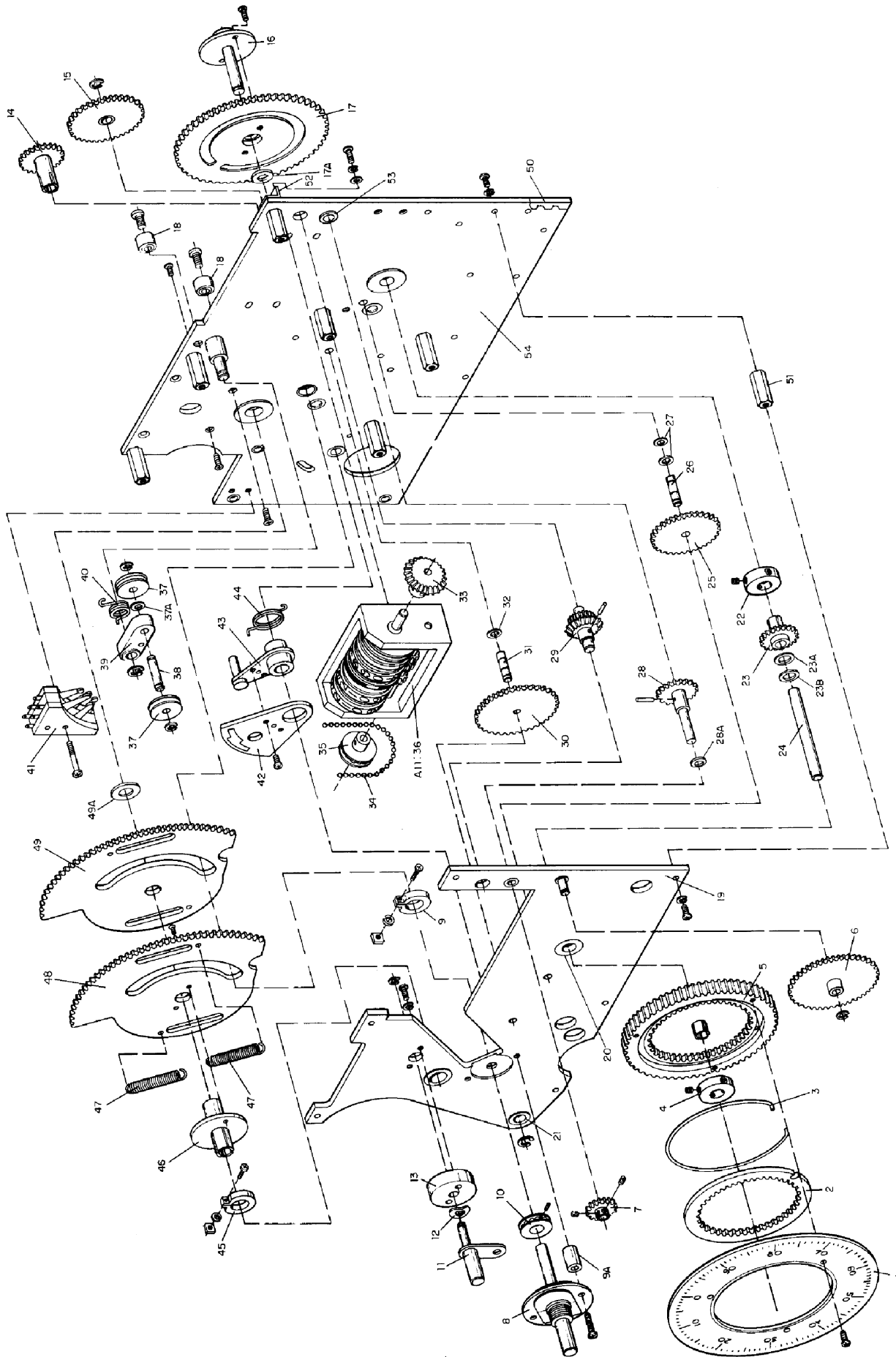

Gear Train Assembly
Figure 6-7

TP3-8407-014

GROUP ASSEMBLY PARTS LIST

FIG - ITEM	PART NO	INDENT	DESCRIPTION	USABLE ON CODE	UNITS PER ASSY
6-7 -	547-2694-005	1	GEAR TRAIN ASSY (SEE 6-6-12 FOR NHA)		REF
1	547-2559-002	2	DIAL, SCALE		1
1	547-2602-002	2	SCREW		3
2	547-2574-002	2	GEAR, INTERNAL		1
3	549-4441-002	2	DIAL SPRING		1
4	547-2556-002	2	CLAMP, DIAL		1
5	547-2615-003	2	GEAR CLUSTER		1
6	547-2576-002	2	GEAR, SPUR		1
7	547-2572-002	2	GEAR, SPUR-21T		1
8	212365F	2	DETENT, SW (V76854) 269-2224-000		1
9	506-3189-002	2	GEAR CLAMP		1
9A	547-5967-002	2	SPACEP, SLEEVE		2
10	547-2592-002	2	SPROCKET		1
11	547-2584-002	2	ZERO, ARM		1
12	547-2554-002	2	WASHER, SPRING		1
13	547-2558-002	2	BLOCK, BEARING		1
14	547-2541-002	2	GEAR, SPUR-18T		1
15	547-2578-002	2	GEAR, SPUR-32T		1
16	547-2537-002	2	SHAFT, SHOULDER (REPLACE WITH 606-9739-001)		1
16	606-9739-001	2	SHAFT (REPLACES 547-2537-002)		1
17	547-2543-002	2	GEAR, SPUR-126T		1
17A	500-1126-003	2	WASHER, FLAT		2
18	756-0480-001	2	BEARING, SLEFVE		2
19	547-2623-003	2	PLATE, GEAR		1
20	547-3738-000	3	BEARING, SLEEVE		1
21	F347-4MILL6085	3	BEARING, SLV (V12204) 309-0125-000		1
22	547-2556-002	2	CLAMP, DIAL		1
23	547-2539-002	2	GEAR, SPUR-42T		1
23A	541-1200-003	2	WASHER, SHIM		AR
23B	541-1237-003	2	WASHER, SHIM		AR
24	547-2560-002	2	SHAFT, STRAIGHT		1
25	547-2579-002	2	GEAR, SPUR-66T		1
26	547-2561-002	2	SHAFT, GROOVED		1
27	500-1073-003	2	WASHER		2
28	547-2585-002	2	GEARSHAFT, SPUR -35T		1
28A	757-2839-001	2	WASHER, SHIM		AR
29	547-2593-002	2	GEARSHAFT, BEVEL-SPUR-21T		1
30	547-2577-002	2	GEARCLUSTER		1
31	547-2561-002	2	SHAFT, GROOVED		1
32	500-1073-003	2	WASHER		2
33	547-2595-002	2	GEAR, BEVEL		1
34	015-1622-000	2	CHAIN, BEAD (V70892) 015-1622-000		1
35	547-2601-002	2	SPROCKET, COUNTER SHAFT		1
36	1145100	2	COUNTER, ROT (V62869) 015-1220-000 A11		1
37	547-2600-002	2	PULLEY, IDLER (REPLACE WITH 547-2553-002)		2
37	547-2553-002	2	PULLEY, IDLER (REPLACES 547-2600-000)		2
37A	504-0717-003	2	WASHER, FLAT		1
38	547-2598-002	2	SHAFT, IDLER		1
39	547-2552-002	2	ARM, IDLER		1
40	547-2557-002	2	SPRING, HELICAL		1
41	547-2715-003	2	CONTACT ASSEMBLY		1
42	547-2548-002	2	SEGMENT, SWITCH		1
43	547-2590-002	2	ARM, DRIVER		1
44	547-2650-003	2	SPRING, HELICAL		1
45	504-7537-002	2	CLAMP, LOOP		1
46	547-2563-002	2	HUB, SLUG RACK		1
47	756-4050-002	2	SPRING, HELICAL		2
48	547-2607-003	2	GEAR SECTOR, DRIVE		1
49	547-2606-003	2	GEAR SECTOR		1
49A	542-1602-003	2	WASHER, FLAT		1
50	MS21266-3N	2	PLASTIC CHANNEL (V96906) 150-0177-000		AR
51	547-2575-002	2	POST		7
52	547-2810-002	2	BRACKET, LIGHT		1
53	S418FCHH3P15L02	2	BEARING, BALL, AN (V40920) 309-1518-000		4
54	547-2683-004	2	PLATE, GEAR		1

GROUP ASSEMBLY PARTS LIST

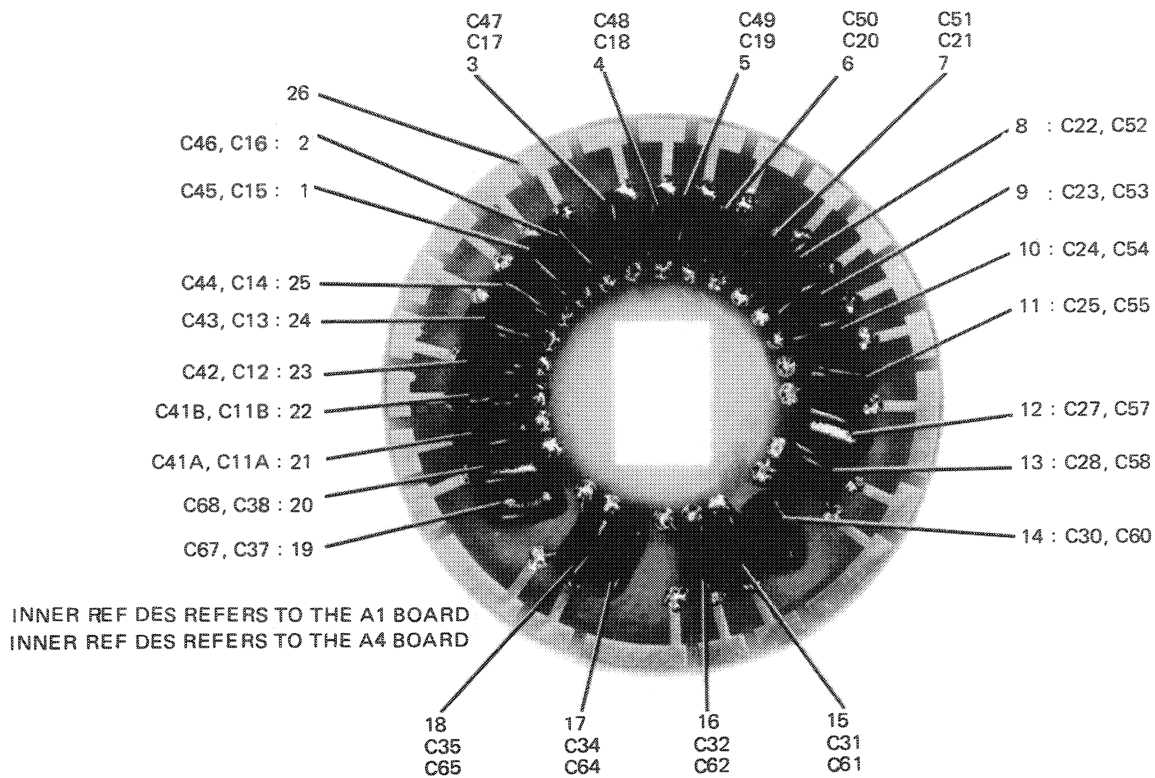

TP3-7994-017

Capacitor Assembly (A1, A4)
Figure 6-8

FIG - ITEM	PART NO	INDENT	DESCRIPTION	USABLE ON CODE	UNITS PER ASSY
6-8 -	547-2680-004	1	CAPACITOR ASSEMBLY A1 ,A4(SEE FIG 6-6-26,29 FOR NHA)		REF
1	CM05FD201G03	2	CAPACITOR,FXD, MICA DIEL, 200PF, 2%, 500V (V81349) 912-2836-000 A1C15 ,A4C45		1
2	CM05FD181G03	2	CAPACITOR,FXD, MICA DIEL, 180PF, 2%, 500V (V81349) 912-2833-000 A1C16 ,A4C46		1
3	CM05FD151G03	2	CAPACITOR,FXD, MICA DIEL, 150PF, 2%, 500V (V81349) 912-2827-000 A1C17 ,A4C47		1
4	CM05FD131G03	2	CAPACITOR,FXD, MICA DIEL, 130PF, 2%, 500V (V81349) 912-2824-000 A1C18 ,A4C48		1
5	CM05FD111G03	2	CAPACITOR,FXD, MICA DIEL, 110PF, 2%, 500V (V81349) 912-2818-000 A1C19 ,A4C49		1
6	CM05FD101G03	2	CAPACITOR,FXD, MICA DIEL, 100PF, 2%, 500V (V81349) 912-2815-000 A1C20 ,A4C50		1
7	CM05FD910G03	2	CAPACITOR,FXD, MICA DIEL, 91PF, 2%, 500V (V81349) 912-2812-000 A1C21 ,A4C51		1
8	CM05ED820G03	2	CAPACITOR,FXD, MICA DIEL, 82PF, 2%, 500V (V81349) 912-2809-000 A1C22 ,A4C52		1
9	CM05ED680G03	2	CAPACITOR,FXD, MICA DIEL, 68PF, 2%, 500V (V81349) 912-2803-000 A1C23 ,A4C53		1
10	CM05ED620G03	2	CAPACITOR,FXD, MICA DIEL, 62PF, 2%, 500V (V81349) 912-2800-000 A1C24 ,A4C54		1

GROUP ASSEMBLY PARTS LIST

FIG - ITEM	PART NO	QTY INDENT	DESCRIPTION	USABLE ON CODE	UNITS PER ASSY
6-8 11	CM05ED56CG03	2	CAPACITOR,FXD, MICA DIEI, 56PF, 2%, 500V (V81349) 912-2797-000 A1C25 ,A4C55		1
12	CM05ED510G03	2	CAPACITOR,FXD, MICA DIEI, 51PF, 2%, 500V (V81349) 912-2794-000 A1C27 ,A4C57		1
13	CM05ED430G03	2	CAPACITOR,FXD, MICA DIEI, 43PF, 2%, 500V (V81349) 912-2788-000 A1C28 ,A4C58		1
14	CM05ED330G03	2	CAPACITOR,FXD, MICA DIEI, 33PF, 2%, 500V (V81349) 912-2779-000 A1C30 ,A4C60		1
15	CM05ED24CJ03	2	CAPACITOR,FXD, MICA DIEI, 24PF, 5%, 500V (V81349) 912-2771-000 A1C31 ,A4C61		1
16	CM05ED200J03	2	CAPACITOR,FXD, MICA DIEI, 20PF, 5%, 500V (V81349) 912-2765-000 A1C32 ,A4C62		1
17	CM05CD15CJ03	2	CAPACITOR,FXD, MICA DIEI, 15PF, 5%, 500V (V81349) 912-2759-000 A1C34 ,A4C64		1
18	CM05CD18CJ03	2	CAPACITOR,FXD, MICA DIEI, 18PF, 5%, 500V (V81349) 912-2762-000 A1C35 ,A4C65		1
19	CM05CD15CJ03	2	CAPACITOR,FXD, MICA DIEI, 15PF, 5%, 500V (V81349) 912-2759-000 A1C37 ,A4C67		1
20	CM05CD12CJ03	2	CAPACITOR,FXD, MICA DIEI, 12PF, 5%, 500V (V81349) 912-2756-000 A1C38 ,A4C68		1
21	DM15F511G300WV4C P	2	CAPACITOR,FXD, MICA DIEI, 510PF, 2%, 300V (V72136) 912-2866-000 A1C11A ,A4C41A		1
22	CM05FD331G03	2	CAPACITOR,FXD, MICA DIEI, 330PF, 2%, 500V (V81349) 912-2851-000 A1C11B ,A4C41B		1
23	DM15F431G300WV4C R	2	CAPACITOR,FXD, MICA DIEI, 430PF, 2%, 300V (V72136) 912-2860-000 A1C12 ,A4C42		1
24	CM05FD301G03	2	CAPACITOR,FXD, MICA DIEI, 300PF, 2%, 500V (V81349) 912-2848-000 A1C13 ,A4C43		1
25	DM15E2520G0500WV 4CR	2	CAPACITOR,FXD, MICA DIEI, 252PF, 2%, 500V (V72136) 912-3485-000 A1C14 ,A4C44		1
26	547-2676-004	2	DISC,CAPACITOR		1

section 6
parts list

GROUP ASSEMBLY PARTS LIST

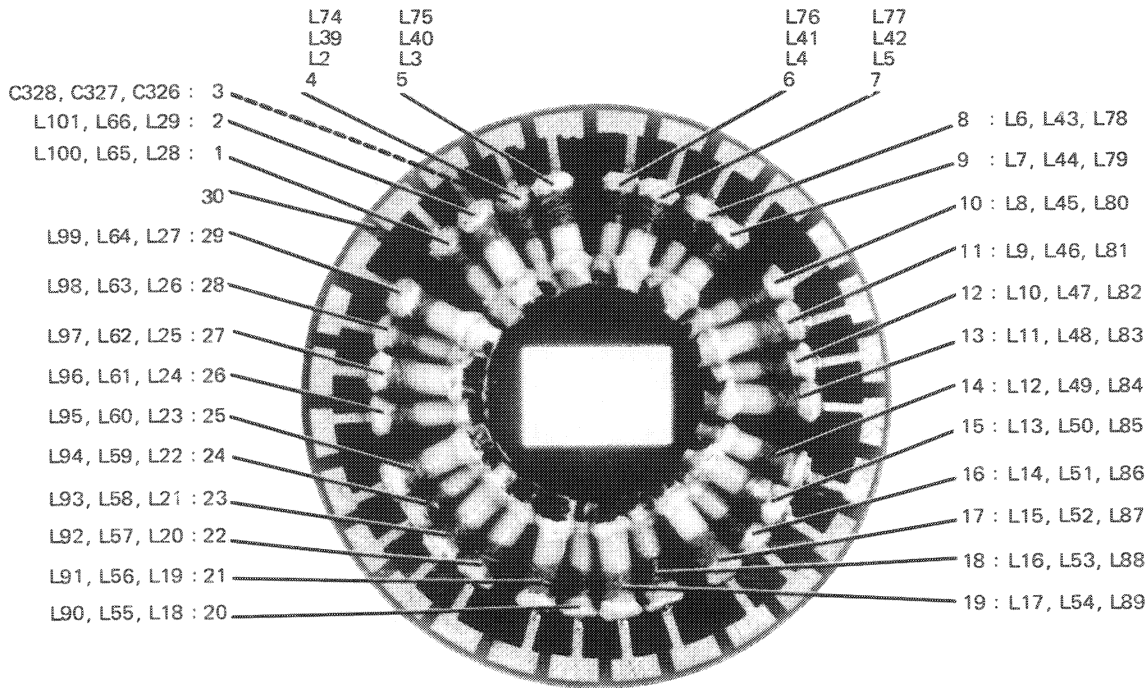

INNER REF DES REFERS TO THE A2 BOARD
MIDDLE REF DES REFERS TO THE A5 BOARD
OUTER REF DES REFERS TO THE A6 BOARD

TP3-7992-017

Coil Assembly (A2, A5, A6)
Figure 6-9

FIG - ITEM	PART NO	INDENT	DESCRIPTION	USABLE ON CODE	UNITS PER ASSY
6-9 -	547-2685-004	1	COIL ASSEMBLY A2 ,A5,A6 (SEE FIG 6-6-27,30,31 FOR NHA)		REF
1	X352-1	2	INDUCTANCE STD (V81815) 240-1144-000 A2L28, A5L65,A6L100 (EFF TO CI 71403)		1
1	609-1247-001	2	COIL,RF A2L28 ,A5L65,A5L100 (EFF CI 71403)		1
2	X352-1	2	INDUCTANCE STD (V81815) 240-1144-000 A2L29, A5L66,A6L101 (EFF TO CI 71403)		1
2	609-1247-001	2	COIL,RF A2L29 ,A5L66,A6L101 (EFF CI 71403)		1
3	8111R203COG0-309 C	2	CAPACITOR,FXD, CER DIEL, 3PF, 0.25PF, 150V (V72982) 913-1098-340 A2C326 (EFF CI 70383 TO REV LTR F)		1
4	X333-1	2	INDUCTANCE STD (V81815) 240-1125-000 A2L2 ,A5L39, A6L74 (EFF TO CI 71403)		1
4	609-1241-001	2	COIL,RF A2L2 ,A5L39,A6L74 (EFF CI 71403)		1
5	X334-1	2	INDUCTANCE STD (V81815) 240-1126-000 A2L3 ,A5L40, A6L75 (EFF TO CI 71403)		1
5	609-1242-001	2	COIL,RF A2L3 ,A5L40,A6L75 (EFF CI 71403)		1
6	X336-1	2	INDUCTANCE STD (V81815) 240-1128-000 A2L4 ,A5L41, A6L76 (EFF TO CI 71403)		1
6	609-1243-001	2	COIL,RF A2L4 ,A5L41,A6L76 (EFF CI 71403)		1
7	X337-1	2	INDUCTANCE STD (V81815) 240-1129-000 A2L5 ,A5L42, A6L77 (EFF TO CI 71403)		1
7	609-1243-001	2	COIL,RF A2L5 ,A5L42,A6L77 (EFF CI 71403)		1
8	X350-1	2	INDUCTANCE STD (V81815) 240-1142-000 A2L6 ,A5L43, A6L78 (EFF TO CI 71403)		1

GROUP ASSEMBLY PARTS LIST

FIG - ITEM	PART NO	INDENT	DESCRIPTION	USABLE ON CODE	UNITS PER ASSY
6-9					
8	609-1244-001	2	COIL,RF A2L6 ,A5L43,A6L78 (EFF CI 71403)		1
9	X339-1	2	INDUCTANCE STD (V81815) 240-1131-000 A2L7 ,A5L44, A6L79 (EFF TO CI 71403)		1
9	609-1244-001	2	COIL,RF A2L7 ,A5L44,A6L79 (EFF CI 71403)		1
10	X339-1	2	INDUCTANCE STD (V81815) 240-1131-000 A2L8 ,A5L45, A6L80 (EFF TO CI 71403)		1
10	609-1244-001	2	COIL,RF A2L8 ,A5L45,A6L80 (EFF CI 71403)		1
11	X340-1	2	INDUCTANCE STD (V81815) 240-1132-000 A2L9 ,A5L46, A6L81 (EFF TO CI 71403)		1
11	609-1244-001	2	COIL,RF A2L9 ,A5L46,A6L81 (EFF CI 71403)		1
12	X340-1	2	INDUCTANCE STD (V81815) 240-1132-000 A2L10, A5L47,A6L82 (EFF TO CI 71403)		1
12	609-1245-001	2	COIL,RF A2L10 ,A5L47,A6L82 (EFF CI 71403)		1
13	X341-1	2	INDUCTANCE STD (V81815) 240-1133-000 A2L11, A5L48,A6L83 (EFF TO CI 71403)		1
13	609-1245-001	2	COIL,RF A2L11 ,A5L48,A6L83 (EFF CI 71403)		1
14	X341-1	2	INDUCTANCE STD (V81815) 240-1133-000 A2L12, A5L49,A6L84 (EFF TO CI 71403)		1
14	609-1245-001	2	COIL,RF A2L12 ,A5L49,A6L84 (EFF CI 71403)		1
15	X341-1	2	INDUCTANCE STD (V81815) 240-1133-000 A2L13, A5L50,A6L85 (EFF TO CI 71403)		1
15	609-1245-001	2	COIL,RF A2L13 ,A5L50,A6L85 (EFF CI 71403)		1
16	X341-1	2	INDUCTANCE STD (V81815) 240-1133-000 A2L14, A5L51,A6L86 (EFF TO CI 71403)		1
16	609-1245-001	2	COIL,RF A2L14 ,A5L51,A6L86 (EFF CI 71403)		1
17	X342-1	2	INDUCTANCE STD (V81815) 240-1134-000 A2L15, A5L52,A6L87 (EFF TO CI 71403)		1
17	609-1245-001	2	COIL,RF A2L15 ,A5L52,A6L87 (EFF CI 71403)		1
18	X343-1	2	INDUCTANCE STD (V81815) 240-1135-000 A2L16, A5L53,A6L88 (EFF TO CI 71403)		1
18	609-1245-001	2	COIL,RF A2L16 ,A5L53,A6L88 (EFF CI 71403)		1
19	X345-1	2	INDUCTANCE STD (V81815) 240-1137-000 A2L17, A5L54,A6L89 (EFF TO CI 71403)		1
19	609-1246-001	2	COIL,RF A2L17 ,A5L54,A6L89 (EFF CI 71403)		1
20	X351-1	2	INDUCTANCE STD (V81815) 240-1143-000 A2L18, A5L55,A6L90 (EFF TO CI 71403)		1
20	609-1246-001	2	COIL,RF A2L18 ,A5L55,A6L90 (EFF CI 71403)		1
21	X351-1	2	INDUCTANCE STD (V81815) 240-1143-000 A2L19, A5L56,A6L91 (EFF TO CI 71403)		1
21	609-1246-001	2	COIL,RF A2L19 ,A5L56,A6L91 (EFF CI 71403)		1
22	X347-1	2	INDUCTANCE STD (V81815) 240-1139-000 A2L20, A5L57,A6L92 (EFF TO CI 71403)		1
22	609-1246-001	2	COIL,RF A2L20 ,A5L57,A6L92 (EFF CI 71403)		1
23	X347-1	2	INDUCTANCE STD (V81815) 240-1139-000 A2L21, A5L58,A6L93 (EFF TO CI 71403)		1
23	609-1246-001	2	COIL,RF A2L21 ,A5L58,A6L93 (EFF CI 71403)		1
24	X347-1	2	INDUCTANCE STD (V81815) 240-1139-000 A2L22, A5L59,A6L94 (EFF TO CI 71403)		1
24	609-1246-001	2	COIL,RF A2L22 ,A5L59,A6L94 (EFF CI 71403)		1
25	X347-1	2	INDUCTANCE STD (V81815) 240-1139-000 A2L23, A5L60,A6L95 (EFF TO CI 71403)		1
25	609-1246-001	2	COIL,RF A2L23 ,A5L60,A6L95 (EFF CI 71403)		1
26	X348-1	2	INDUCTANCE STD (V81815) 240-1140-000 A2L24, A5L61,A6L96 (EFF TO CI 71403)		1
26	609-1247-001	2	COIL,RF A2L24 ,A5L61,A6L96 (EFF CI 71403)		1
27	X348-1	2	INDUCTANCE STD (V81815) 240-1140-000 A2L25, A5L62,A6L97 (EFF TO CI 71403)		1
27	609-1247-001	2	COIL,RF A2L25 ,A5L62,A6L97 (EFF CI 71403)		1
28	X349-1	2	INDUCTANCE STD (V81815) 240-1141-000 A2L26, A5L63,A6L98 (EFF TO CI 71403)		1
28	609-1247-001	2	COIL,RF A2L26 ,A5L63,A6L98 (EFF CI 71403)		1
29	X349-1	2	INDUCTANCE STD (V81815) 240-1141-000 A2L27, A5L64,A6L99 (EFF TO CI 71403)		1
29	609-1247-001	2	COIL,RF A2L27 ,A5L64,A6L99 (EFF CI 71403)		1
30	547-2813-004		DISC,COIL		

GROUP ASSEMBLY PARTS LIST

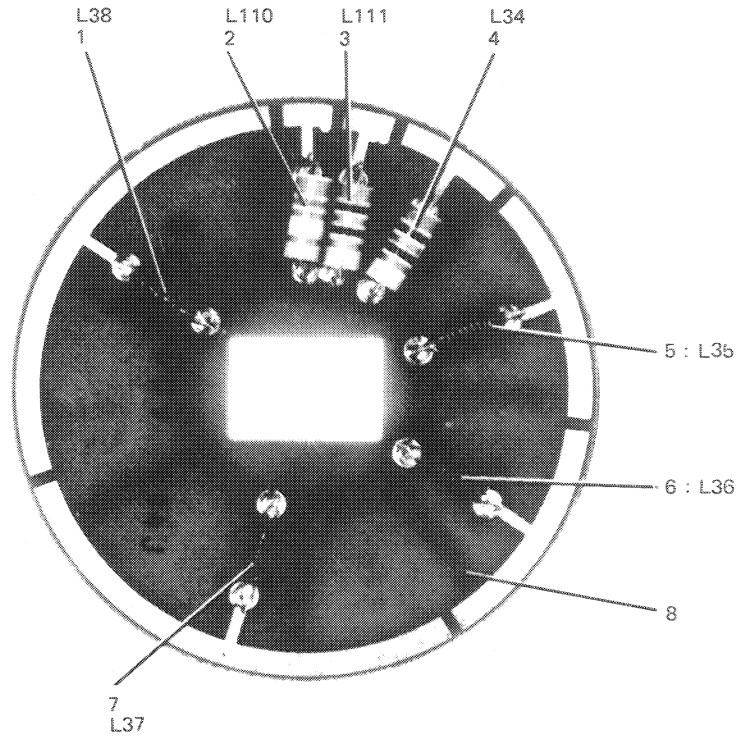

TP3-7988-017

Coupling Coil Assembly (A3)
Figure 6-10

FIG - ITEM	PART NO	INDENT	DESCRIPTION	USABLE ON CODE	UNITS PER ASSY
6-10 -	547-2682-004	1	COIL ASSEMBLY, COUPLING A3 (SEE FIG 6-6-28 FOR NHA)		REF
1	547-2618-003	2	COIL,RF A3L38		1
2	MS75008-35	2	COIL,RF, 3.9UH (V96906) 240-0144-000 A3L110 (EFF TO REV F)		1
2	MS75101-2	2	COIL,RF, 3.9UH (V96906) 240-1595-000 A3L110 (EFF REV LTR F)		1
3	LT4K036	2	COIL,RF, 1.5UH (V81349) 240-0063-000 A3L111 (EFF TO REV LTR F)		1
3	MS75008-30	2	COIL,RF, 1.5UH (V96906) 240-1591-000 A3L111 (EFF REV LTR F)		1
4	LT4K034	2	COIL,RF, 1UH (V81349) 240-0062-000 A3L34 (EFF TO REV LTR F)		1
4	MS75008-28	2	COIL,RF, 1UH (V96906) 240-1590-000 A3L34 (EFF REV LTR F)		1
5	547-2619-003	2	COIL,RF A3L35		1
6	547-2617-003	2	COIL,RF A3L36		1
7	547-2618-003	2	COIL,RF A3L37		1
8	547-2670-004	2	DISC,COUPLING		1

GROUP ASSEMBLY PARTS LIST

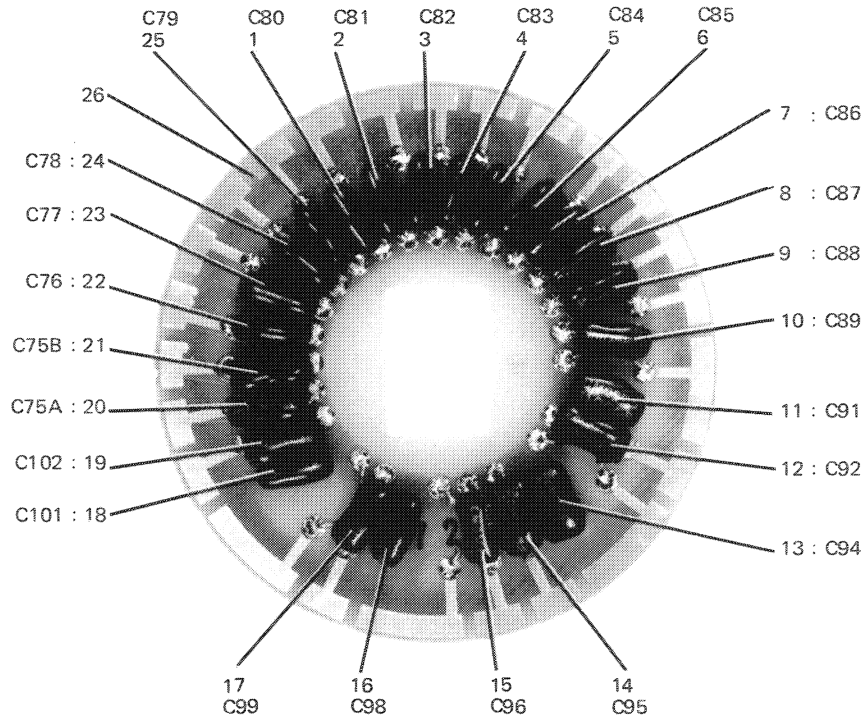

TP3-7993-017

Capacitor Assembly (A7)
Figure 6-11

FIG - ITEM	PART NO	INDENT	DESCRIPTION	USABLE ON CODE	UNITS PER ASSY
6-11 -	549-0630-004	1	CAPACITOR ASSEMBLY A7 (SEE FIG 6-6-32 FOR VHA)		REF
1	CM05FD181G03	2	CAPACITOR,FXD, MICA DIEI, 180PF, 2%, 500V (V81349) 912-2833-000 A7C80		1
2	CM05FD151G03	2	CAPACITOR,FXD, MICA DIEI, 150PF, 2%, 500V (V81349) 912-2827-000 A7C81		1
3	CM05FD131G03	2	CAPACITOR,FXD, MICA DIEI, 130PF, 2%, 500V (V81349) 912-2824-000 A7C82		1
4	CM05FD111G03	2	CAPACITOR,FXD, MICA DIEI, 110PF, 2%, 500V (V81349) 912-2818-000 A7C83		1
5	CM05FD101G03	2	CAPACITOR,FXD, MICA DIEI, 100PF, 2%, 500V (V81349) 912-2815-000 A7C84		1
6	CM05FD910G03	2	CAPACITOR,FXD, MICA DIEI, 91PF, 2%, 500V (V81349) 912-2812-000 A7C85		1
7	CM05ED820G03	2	CAPACITOR,FXD, MICA DIEI, 82PF, 2%, 500V (V81349) 912-2809-000 A7C86		1
8	CM05ED680G03	2	CAPACITOR,FXD, MICA DIEI, 68PF, 2%, 500V (V81349) 912-2803-000 A7C87		1
9	CM05ED620G03	2	CAPACITOR,FXD, MICA DIEI, 62PF, 2%, 500V (V81349) 912-2800-000 A7C88		1
10	CM05ED560G03	2	CAPACITOR,FXD, MICA DIEI, 56PF, 2%, 500V (V81349) 912-2797-000 A7C89		1
11	CM05ED510G03	2	CAPACITOR,FXD, MICA DIEI, 51PF, 2%, 500V (V81349) 912-2794-000 A7C91		1
12	CM05ED430G03	2	CAPACITOR,FXD, MICA DIEI, 43PF, 2%, 500V (V81349) 912-2788-000 A7C92		1
13	CM05ED330G03	2	CAPACITOR,FXD, MICA DIEI, 33PF, 2%, 500V (V81349) 912-2779-000 A7C94		1

GROUP ASSEMBLY PARTS LIST

FIG - ITEM	PART NO	INDENT	DESCRIPTION	USABLE ON CODE	UNITS PER ASSY
6-11 14	CM05ED240J03	2	CAPACITOR,FXD, MICA DIEI, 24PF, 5%, 50JV (V81349) 912-2771-000 A7C95		1
15	CM05ED200J03	2	CAPACITOR,FXD, MICA DIEI, 20PF, 5%, 500V (V81349) 912-2765-000 A7C96		1
16	CM05CD150J03	2	CAPACITOR,FXD, MICA DIEI, 15PF, 5%, 500V (V81349) 912-2759-000 A7C98		1
17	CM05CD180J03	2	CAPACITOR,FXD, MICA DIEI, 18PF, 5%, 500V (V81349) 912-2762-000 A7C99		1
18	CM05CD150J03	2	CAPACITOR,FXD, MICA DIEI, 15PF, 5%, 500V (V81349) 912-2759-000 A7C101		1
19	CM05CD120J03	2	CAPACITOR,FXD, MICA DIEI, 12PF, 5%, 500V (V81349) 912-2756-000 A7C102		1
20	DM15F511G3C0WV4C R	2	CAPACITOR,FXD, MICA DIEI, 510PF, 2%, 300V (V72136) 912-2866-000 A7C75A		1
21	CM05FD331G03	2	CAPACITOR,FXD, MICA DIEI, 330PF, 2%, 500V (V81349) 912-2851-000 A7C75B		1
22	DM15F4350F3C0WV4 CR	2	CAPACITOR,FXD, MICA DIEI, 435PF, 1%, 300V (V72136) 912-3987-000 A7C76		1
23	CM05FD331G03	2	CAPACITOR,FXD, MICA DIEI, 330PF, 2%, 500V (V81349) 912-2851-000 A7C77		1
24	DM15E2520G0500WV 4CR	2	CAPACITOR,FXD, MICA DIEI, 252PF, 2%, 500V (V72136) 912-3485-000 A7C78		1
25	CM05FD221G03	2	CAPACITOR,FXD, MICA DIEI, 220PF, 2%, 500V (V81349) 912-2839-000 A7C79		1
26	547-2676-004	2	DISC,CAPACITOR		1

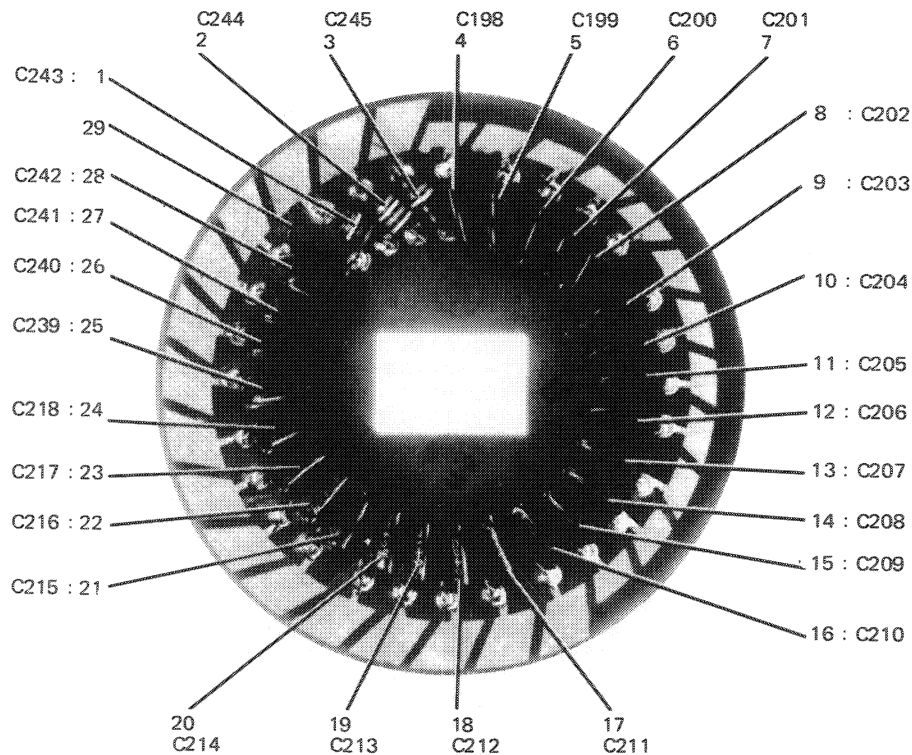

TP3-7991-017

Crystal Oscillator Capacitor Assembly (A8)
Figure 6-12

GROUP ASSEMBLY PARTS LIST

FIG - ITEM	PART NO	INDENT	DESCRIPTION	USABLE ON CODE	UNITS PER ASSY
6-12 -	547-2681-004	1	CAPACITOR ASSEMBLY, CRYSTAL OSCILLATOR A3 (SEE FIG 6-6-35 FOR NHA)		REF
1	QC8-20UF5PCT	2	CAPACITOR, FXD, CER DIEI, 8.2PF, 5%, 500V (V95121) 913-2998-000 ABC243		1
2	QC4-70UF5PCT	2	CAPACITOR, FXD, CER DIEI, 4.7PF, 5%, 500V (V95121) 913-2993-000 ABC244		1
3	QC1-10UF5PCT	2	CAPACITOR, FXD, CER DIEI, 1.1PF, 5%, 500V (V95121) 913-2978-000 ABC245		1
4	CM05ED560G03	2	CAPACITOR, FXD, MICA DIEI, 56PF, 2%, 500V (V81349) 912-2797-000 ABC198		1
5	CM05ED580G03	2	CAPACITOR, FXD, MICA DIEI, 68PF, 2%, 500V (V81349) 912-2803-000 ABC199		1
6	CM05FD910G03	2	CAPACITOR, FXD, MICA DIEI, 91PF, 2%, 500V (V81349) 912-2812-000 ABC200		1
7	CM05FD121G03	2	CAPACITOR, FXD, MICA DIEI, 120PF, 2%, 500V (V81349) 912-2821-000 ABC201		1
8	CM05FD161G03	2	CAPACITOR, FXD, MICA DIEI, 160PF, 2%, 500V (V81349) 912-2830-000 ABC202		1
9	CM05FD111G03	2	CAPACITOR, FXD, MICA DIEI, 110PF, 2%, 500V (V81349) 912-2818-000 ABC203		1
10	CM05ED820G03	2	CAPACITOR, FXD, MICA DIEI, 82PF, 2%, 500V (V81349) 912-2809-000 ABC204		1
11	CM05ED620G03	2	CAPACITOR, FXD, MICA DIEI, 62PF, 2%, 500V (V81349) 912-2800-000 ABC205		1
12	CM05ED510G03	2	CAPACITOR, FXD, MICA DIEI, 51PF, 2%, 500V (V81349) 912-2794-000 ABC206		1
13	CM05ED360G03	2	CAPACITOR, FXD, MICA DIEI, 36PF, 2%, 500V (V81349) 912-2782-000 ABC207		1
14	CM05ED270G03	2	CAPACITOR, FXD, MICA DIEI, 27PF, 2%, 500V (V81349) 912-2773-000 ABC208		1
15	CM05ED200J03	2	CAPACITOR, FXD, MICA DIEI, 20PF, 5%, 500V (V81349) 912-2765-000 ABC209		1
16	DM15E1140G0500WV4CR	2	CAPACITOR, FXD, MICA DIEI, 114PF, 2%, 500V (V72136) 912-3482-000 ABC210		1
17	CM05FD101G03	2	CAPACITOR, FXD, MICA DIEI, 100PF, 2%, 500V (V81349) 912-2815-000 ABC211		1
18	CM05ED820G03	2	CAPACITOR, FXD, MICA DIEI, 82PF, 2%, 500V (V81349) 912-2809-000 ABC212		1
19	DM15E710G0500WV4CR	2	CAPACITOR, FXD, MICA DIEI, 71PF, 2%, 500V (V72136) 912-3479-000 ABC213		1
20	CM05ED620G03	2	CAPACITOR, FXD, MICA DIEI, 62PF, 2%, 500V (V81349) 912-2800-000 ABC214		1
21	CM05ED510G03	2	CAPACITOR, FXD, MICA DIEI, 51PF, 2%, 500V (V81349) 912-2794-000 ABC215		1
22	CM05ED430G03	2	CAPACITOR, FXD, MICA DIEI, 43PF, 2%, 500V (V81349) 912-2788-000 ABC216		1
23	CM05ED360G03	2	CAPACITOR, FXD, MICA DIEI, 36PF, 2%, 500V (V81349) 912-2782-000 ABC217		1
24	CM05ED300G03	2	CAPACITOR, FXD, MICA DIEI, 30PF, 2%, 500V (V81349) 912-2776-000 ABC218		1
25	DM15E240K500WV4CR	2	CAPACITOR, FXD, MICA DIEI, 24PF, 10%, 500V (V72136) 912-2772-000 ABC239		1
26	CM05ED200J03	2	CAPACITOR, FXD, MICA DIEI, 20PF, 5%, 500V (V81349) 912-2765-000 ABC240		1
27	CM05CD150J03	2	CAPACITOR, FXD, MICA DIEI, 15PF, 5%, 500V (V81349) 912-2759-000 ABC241		1
28	CM05CD120J03	2	CAPACITOR, FXD, MICA DIEI, 12PF, 5%, 500V (V81349) 912-2756-000 ABC242		1
29	547-2679-004	2	DISC, CAPACITOR		1

GROUP ASSEMBLY PARTS LIST

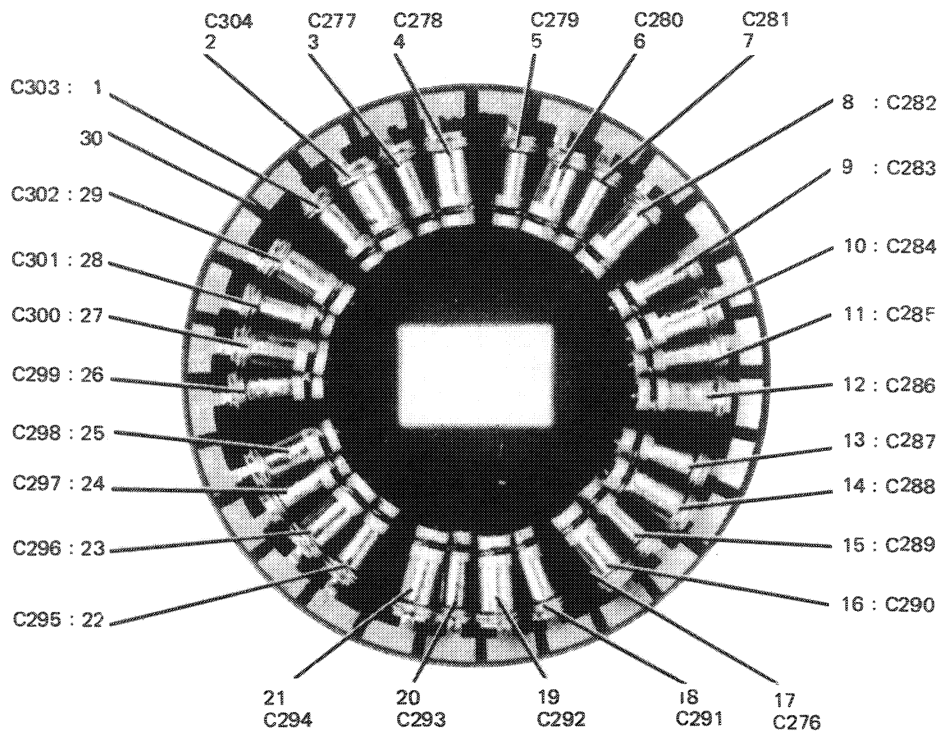

TP3-7989-017

Trimmer Capacitor Assembly (A9)
Figure 6-13

FIG-- ITEM	PART NO	INDENT	DESCRIPTION	USABLE ON CODE	UNITS PER ASSY
6-13 -	547-2691-004	1	CAPACITOR ASSEMBLY, TRIMMER A9 (SEE FIG 6-6-36 FOR NHA)		REF
1	3221-201	2	CAPACITOR, VAR, CER DIEI, 2PF 10PF, 100V (V72982) 917-1180-000 A9C303		1
2	3221-201	2	CAPACITOR, VAR, CER DIEI, 2PF 10PF, 100V (V72982) 917-1180-000 A9C304		1
3	3221-201	2	CAPACITOR, VAR, CER DIEI, 2PF 10PF, 100V (V72982) 917-1180-000 A9C277		1
4	3221-201	2	CAPACITOR, VAR, CER DIEI, 2PF 10PF, 100V (V72982) 917-1180-000 A9C278		1
5	3221-201	2	CAPACITOR, VAR, CER DIEI, 2PF 10PF, 100V (V72982) 917-1180-000 A9C279		1
6	3221-201	2	CAPACITOR, VAR, CER DIEI, 2PF 10PF, 100V (V72982) 917-1180-000 A9C280		1
7	3221-201	2	CAPACITOR, VAR, CER DIEI, 2PF 10PF, 100V (V72982) 917-1180-000 A9C281		1
8	3221-201	2	CAPACITOR, VAR, CER DIEI, 2PF 10PF, 100V (V72982) 917-1180-000 A9C282		1
9	3221-201	2	CAPACITOR, VAR, CER DIEI, 2PF 10PF, 100V (V72982) 917-1180-000 A9C283		1
10	3221-201	2	CAPACITOR, VAR, CER DIEI, 2PF 10PF, 100V (V72982) 917-1180-000 A9C284		1
11	3221-201	2	CAPACITOR, VAR, CER DIEI, 2PF 10PF, 100V (V72982) 917-1180-000 A9C285		1
12	3221-201	2	CAPACITOR, VAR, CER DIEI, 2PF 10PF, 100V (V72982) 917-1180-000 A9C286		1
13	3221-201	2	CAPACITOR, VAR, CER DIEI, 2PF 10PF, 100V (V72982) 917-1180-000 A9C287		1
14	3221-201	2	CAPACITOR, VAR, CER DIEI, 2PF 10PF, 100V (V72982) 917-1180-000 A9C288		1
15	3221-201	2	CAPACITOR, VAR, CER DIEI, 2PF 10PF, 100V (V72982) 917-1180-000 A9C289		1

GROUP ASSEMBLY PARTS LIST

FIG - ITEM	PART NO	INDENT	DESCRIPTION	USABLE ON CODE	UNITS PER ASSY
6-13 16	3221-201	2	CAPACITOR,VAR, CER DIEL, 2PF 10PF, 100V (V72982) 917-1180-000 A9C290		1
17	QC5-1UUF5PCT	2	CAPACITOR,FXD, CER DIEL, 3.1PF, 5%, 500V (V95121) 913-2994-000 A9C276		1
18	3221-201	2	CAPACITOR,VAR, CER DIEL, 2PF 10PF, 100V (V72982) 917-1180-000 A9C291		1
19	3221-201	2	CAPACITOR,VAR, CER DIEL, 2PF 10PF, 100V (V72982) 917-1180-000 A9C292		1
20	3221-201	2	CAPACITOR,VAR, CER DIEL, 2PF 10PF, 100V (V72982) 917-1180-000 A9C293		1
21	3221-201	2	CAPACITOR,VAR, CER DIEL, 2PF 10PF, 100V (V72982) 917-1180-000 A9C294		1
22	3221-201	2	CAPACITOR,VAR, CER DIEL, 2PF 10PF, 100V (V72982) 917-1180-000 A9C295		1
23	3221-201	2	CAPACITOR,VAR, CER DIEL, 2PF 10PF, 100V (V72982) 917-1180-000 A9C296		1
24	3221-201	2	CAPACITOR,VAR, CER DIEL, 2PF 10PF, 100V (V72982) 917-1180-000 A9C297		1
25	3221-201	2	CAPACITOR,VAR, CER DIEL, 2PF 10PF, 100V (V72982) 917-1180-000 A9C298		1
26	3221-201	2	CAPACITOR,VAR, CER DIEL, 2PF 10PF, 100V (V72982) 917-1180-000 A9C299		1
27	3221-201	2	CAPACITOR,VAR, CER DIEL, 2PF 10PF, 100V (V72982) 917-1180-000 A9C300		1
28	3221-201	2	CAPACITOR,VAR, CER DIEL, 2PF 10PF, 100V (V72982) 917-1180-000 A9C301		1
29	3221-201	2	CAPACITOR,VAR, CER DIEL, 2PF 10PF, 100V (V72982) 917-1180-000 A9C302		1
30	547-2690-004	2	DISC,CAPACITOR		1

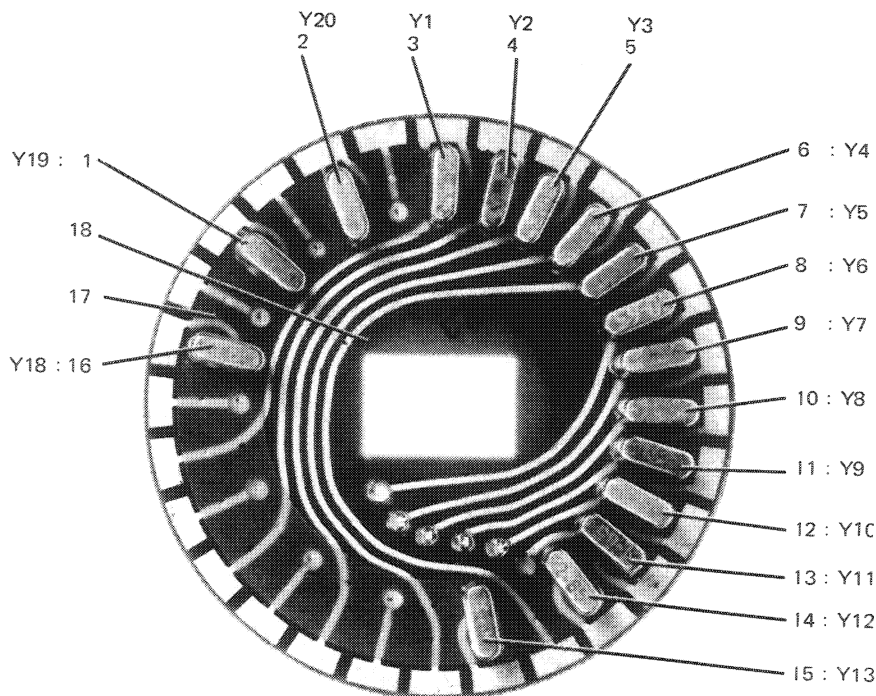

TP3-7990-017

Crystal Assembly (A10)
Figure 6-14

section 6
parts list

GROUP ASSEMBLY PARTS LIST

FIG - ITEM	PART NO	INDENT	DESCRIPTION	USABLE ON CODE	UNITS PER ASSY
6-14 -	547-2677-004	1	CRYSTAL ASSEMBLY A10 (SEE FIG 6-6-37 FOR NHA)		REF
1	289-1580-00M20	2	XTAL UNIT,QTZ, 14500.00KHZ (V00136) 289-1580-000 A10Y19		1
2	289-6996-020M20	2	XTAL UNIT,QTZ, 10332.50KHZ (V94148) 289-6996-020 A10Y20		1
3	289-1567-00M20	2	XTAL UNIT,QTZ, 12500.00KHZ (V00136) 289-1567-000 A10Y1		1
4	289-1568-00M20	2	XTAL UNIT,QTZ, 11500.00KHZ (V00136) 289-1568-000 A10Y2		1
5	289-1569-00M20	2	XTAL UNIT,QTZ, 10500.00KHZ (V00136) 289-1569-000 A10Y3		1
6	289-1570-00M20	2	XTAL UNIT,QTZ, 9500.000KHZ (V00136) 289-1570-000 A10Y4		1
7	289-1571-00M20	2	XTAL UNIT,QTZ, 8500.000KHZ (V00136) 289-1571-000 A10Y5		1
8	289-1572-00M20	2	XTAL UNIT,QTZ, 10000.00KHZ (V00136) 289-1572-000 A10Y6		1
9	289-1573-00M20	2	XTAL UNIT,QTZ, 11000.00KHZ (V00136) 289-1573-000 A10Y7		1
10	289-1574-00M20	2	XTAL UNIT,QTZ, 12000.00KHZ (V00136) 289-1574-000 A10Y8		1
11	289-1575-00M20	2	XTAL UNIT,QTZ, 13000.00KHZ (V00136) 289-1575-000 A10Y9		1
12	289-1576-00M20	2	XTAL UNIT,QTZ, 14000.00KHZ (V00136) 289-1576-000 A10Y10		1
13	289-1577-00M20	2	XTAL UNIT,QTZ, 15000.00KHZ (V00136) 289-1577-000 A10Y11		1
14	289-1582-00M20	2	XTAL UNIT,QTZ, 16000.00KHZ (V00136) 289-1582-000 A10Y12		1
15	289-1578-00M20	2	XTAL UNIT,QTZ, 9000.000KHZ (V00136) 289-1578-000 A10Y13		1
16	289-1579-00M20	2	XTAL UNIT,QTZ, 13500.00KHZ (V00136) 289-1579-000 A10Y18		1
17	547-2622-003	2	INSULATOR, CRYSTAL		1
18	547-2672-004	2	DISC,CRYSTAL		1

GROUP ASSEMBLY PARTS LIST

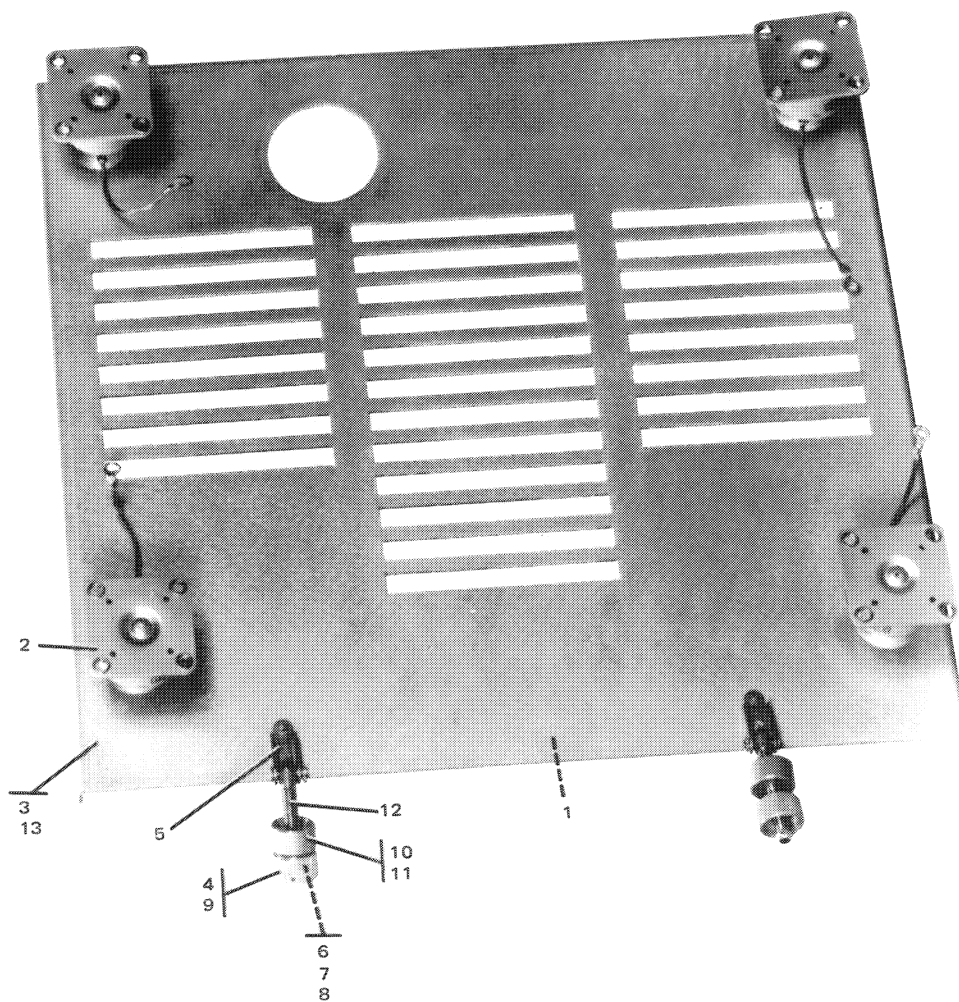

TP3-8409-017

350D-5 Base Shockmount
Figure 6-15

section 6
parts list

GROUP ASSEMBLY PARTS LIST

FIG - ITEM	PART NO	INDENT	DESCRIPTION	USABLE ON CODE	UNITS PER ASSY
6-15 -	522-3970-001	1	SHOCKMOUNT, BASE 350D-5 (SEE FIG 6-1-28 FOR NHA)	D	REF
1	554-4423-001	2	PLATE, IDENT		1
2	770-9G	2	MOUNT, RESIL (V81860) 200-0312-000		4
3	767-6256-001	2	BASE, SHOCKMOUNT		1
4	757-4190-001	3	BOLT ASSY		2
5	541-6506-002	4	CLEVIS		1
6	1-8SSBALL	4	BEARING, BALL (V27545) 309-0019-000		4
7	757-3937-001	4	SPRING		4
8	757-3933-001	4	INSERT		1
9	757-3934-001	4	NUT, THUMB		1
10	757-3935-001	4	PLATE, DETENT		1
11	541-6503-002	4	CLEVIS		1
12	757-3936-001	4	SHAFT		1

6.3 NUMERICAL INDEX

REFERENCE DESIGNATION	FIG - ITEM	PART NUMBER	REFERENCE DESIGNATION	FIG - ITEM	PART NUMBER
BL289-1424-000	6-3-28	1		6-3-61	1
BS217	6-3-139	1		6-3-62	1
	6-3-311	1		6-3-203	1
	6-3-377	1		6-8-12	1
	6-3-399	1		6-8-12	1
B41283-47-40	6-3-117	1		6-11-11	1
	6-3-273	1		6-12-12	1
	6-3-280	1		6-12-21	1
	6-3-421	1	CM05ED560G03	6-8-11	1
B9-7064-010	6-3-17	1		6-8-11	1
CC20CJ030D	6-3-165	1		6-11-10	1
CC20CK010C	6-3-328	1		6-12-4	1
	6-3-330	1	CM05ED620G03	6-3-202	1
CC20CK010D	6-3-306	1		6-3-236	1
CC20CK020C	6-3-192	1		6-3-240	1
	6-3-232	1		6-3-241	1
	6-3-333	1		6-8-10	1
CM04CD100D03	6-3-356	1		6-8-10	1
CM04FD680J03	6-3-325	1		6-11-9	1
CM05CD050D03	6-6-49	1		6-12-11	1
CM05CD100D03	6-3-294	1		6-12-20	1
	6-3-366	1	CM05ED680G03	6-8-9	1
	6-6-48	1		6-8-9	1
CM05CD120J03	6-8-20	1		6-11-8	1
	6-8-20	1		6-12-5	1
	6-11-19	1	CM05ED820G03	6-8-8	1
	6-12-28	1		6-8-8	1
CM05CD150J03	6-8-17	1		6-11-7	1
	6-8-17	1		6-12-10	1
	6-8-19	1		6-12-18	1
	6-8-19	1	CM05FD101G03	6-3-309	1
	6-11-16	1		6-8-6	1
	6-11-18	1		6-8-6	1
	6-12-27	1		6-11-5	1
CM05CD180J03	6-8-18	1		6-12-17	1
	6-8-18	1	CM05FD101J03	6-3-438	1
	6-11-17	1	CM05FD111G03	6-8-5	1
CM05ED200J03	6-3-364	1		6-8-5	1
	6-8-16	1		6-11-4	1
	6-8-16	1		6-12-9	1
	6-11-15	1	CM05FD121G03	6-12-7	1
	6-12-15	1	CM05FD121J03	6-3-164	1
	6-12-26	1	CM05FD131G03	6-8-4	1
CM05ED220J03	6-3-321	1		6-8-4	1
CM05ED240J03	6-8-15	1		6-11-3	1
	6-8-15	1	CM05FD151G03	6-8-3	1
	6-11-14	1		6-8-3	1
CM05ED270G03	6-12-14	1		6-11-2	1
CM05ED300G03	6-12-24	1	CM05FD161G03	6-12-8	1
CM05ED330G03	6-8-14	1	CM05FD181G03	6-8-2	1
	6-8-14	1		6-8-2	1
	6-11-13	1		6-11-1	1
CM05ED360G03	6-12-13	1	CM05FD201G03	6-8-1	1
	6-12-23	1		6-8-1	1
CM05ED390J03	6-3-194	1	CM05FD221G03	6-11-25	1
CM05ED430G03	6-8-13	1	CM05FD301G03	6-8-24	1
	6-8-13	1		6-8-24	1
	6-11-12	1	CM05FD331G03	6-8-22	1
	6-12-22	1		6-8-22	1
CM05ED470J03	6-3-127	1		6-11-21	1
	6-3-310	1		6-11-23	1
	6-3-369	1	CM05FD331J03	6-3-112	1
CM05ED510G03	6-3-57	1		6-3-153	1

section 6
parts list

REFERENCE DESIGNATION INDEX

REFERENCE DESIGNATION	FIG - ITEM	PART NUMBER	REFERENCE DESIGNATION	FIG - ITEM	PART NUMBER
CM05FD331J03	6-3-286	1	KH3491	6-1-17A	
CM05FD361G03	6-6-47	1	LT4K034	6-10-4	1
CM05FD391G03	6-6-50	1	LT4K036	6-10-3	1
	6-6-51	1	LW9778	6-3-413	1
CM05FD391J03	6-3-102	1		6-3-413	1
CM05FD910G03	6-8-7	1	MS15571-2	6-1-20	1
	6-8-7	1	MS18130-9	6-6-78	1
	6-11-6	1		6-6-79	1
	6-12-6	1		6-6-81	1
C13388SS010	6-6-92	24		6-6-84	1
C800	6-5-10	1	MS18130-9	6-6-82	1
	6-5-19	1		6-6-85	1
DM15C150K500WV4C	6-3-108	1	MS21266-1N	6-3-384A	AR
R			MS21266-3N	6-7-50	AR
DM15E1140G05C0WV	6-12-16	1	MS3112E12-10P	6-2-4	1
4CR			MS35489-4	6-3-331	7
DM15E240K500WV4C	6-12-25	1	MS75008-28	6-10-4	1
R			MS75008-30	6-10-3	1
DM15E2520G05C0WV	6-8-25	1	MS75008-35	6-6-74	1
4CR				6-10-2	1
	6-8-25	1	MS75089-15	6-3-139	1
	6-11-24	1	MS75101-2	6-10-2	1
DM15E710G0500WV4	6-12-19	1	MS75103-10	6-5-13	1
CR				6-5-20	1
DM15F101K500WV4C	6-3-105	1		6-5-23	1
R			MS90538-20	6-3-311	1
	6-3-260	1		6-3-377	1
	6-3-375	1	MS90539-15	6-3-169	1
DM15F431G300WV4C	6-8-23	1		6-3-318	1
R				6-3-354	1
	6-8-23	1		6-6-73	1
DM15F4350F300WV4	6-11-22	1	MS90540-07	6-3-173	1
CR			M24251-6-2	6-3-19	2
DM15F471J300WV4C	6-3-102	1		6-3-19	2
R				6-3-19	7
	6-3-398	1	M24251-6-5	6-3-7	5
DM15F511G300WV4C	6-8-21	1		6-3-7	5
R				6-3-7	7
	6-8-21	1	M39012-21-0001	6-2-1	1
	6-11-20	1	PW5-1000-10	6-5-3	1
D27276	6-5-6	1		6-5-4	1
	6-5-47	1	QC1-1UUF5PCT	6-12-3	1
D27950	6-5-14	1	QC4-7UUF5PCT	6-12-2	1
	6-5-15	1	QC5-1UUF5PCT	6-3-275A	AR
D29238	6-4-13	1		6-13-17	1
	6-4-15	1	QC8-2UUF5PCT	6-12-1	1
D29343	6-3-106	1	RCRC7G101KS	6-3-93	1
D31536	6-3-90	1		6-3-166	1
	6-3-289	1		6-3-344	1
D33212	6-3-136	1		6-3-371	1
D33257	6-4-16	1	RCR07G102KS	6-3-373	1
D74543	6-5-21	1		6-3-374	1
E13657	6-3-222	1	RCR07G103KS	6-3-326	1
F02A250V6AS	6-1-26	1		6-3-329	1
	6-5-33	1	RCR07G104KS	6-3-134	1
F02B250V1 1-2AS	6-4-19	1		6-3-144	1
F347-4MILL6085	6-7-21	1		6-3-150	1
GE44	6-1-19	1		6-3-185	1
	6-3-52	1		6-3-230	1
G2522	6-6-91	1		6-3-233	1
HKPHJRZZ	6-4-20	1		6-3-315	1
	6-5-34	1		6-3-351	1
I145100	6-7-36	1		6-3-355	1

REFERENCE DESIGNATION INDEX

REFERENCE DESIGNATION	FIG - ITEM	PART NUMBER	REFERENCE DESIGNATION	FIG - ITEM	PART NUMBER
RCR07G104KS	6-3-363	1	RCR20G104KS	6-3-101	1
RCR07G106KS	6-3-349	1		6-3-288	1
RCR07G122KS	6-6-70	1	RCR20G105KS	6-3-107	1
RCR07G125KS	6-3-163	1		6-3-259	1
RCR07G151KS	6-3-140	1	RCR20G121KS	6-3-172	1
	6-3-145	1	RCR20G122KS	6-3-82	1
RCR07G152KS	6-3-135	1	RCR20G123KS	6-3-392	1
	6-3-137	1		6-3-412	1
RCR07G183KS	6-3-97	1	RCR20G151KS	6-5-24	1
RCR07G221KS	6-3-209	1		6-5-26	1
	6-3-283	1		6-5-28	1
RCR07G222KS	6-3-128	1	RCR20G152JS	6-3-279	1
RCR07G223KS	6-3-121	1	RCR20G221JS	6-3-307	1
	6-3-234	AR	RCR20G221KS	6-3-353	1
	6-3-238	1	RCR20G222KS	6-3-216	1
RCR07G224KS	6-3-87	1		6-3-271	1
	6-3-217	1	RCR20G224KS	6-3-85	1
	6-3-322	1		6-3-218	1
RCR07G271KS	6-3-123	1		6-3-262	1
RCR07G272KS	6-3-118	1		6-3-291	1
RCR07G332KS	6-3-119	1		6-3-297	1
RCR07G333KS	6-3-129	1	RCR20G271JS	6-3-257	1
RCR07G334KS	6-3-168	1	RCR20G3R9JS	6-3-227	1
RCR07G392KS	6-3-312	1	RCR20G330KS	6-3-320	1
RCR07G393KS	6-3-100	1		6-3-365	1
RCR07G395KS	6-3-163A	AR		6-3-391	1
	6-3-195	1	RCR20G331KS	6-3-409	1
RCR07G470KS	6-3-104	1	RCR20G332KS	6-3-92	1
	6-3-175	1		6-3-94	1
	6-3-323	1		6-3-267	1
RCR07G472KS	6-3-415	1	RCR20G334KS	6-3-262	1
RCR07G473KS	6-3-88	1	RCR20G390KS	6-3-265	1
	6-3-186	1	RCR20G470KS	6-3-181	1
	6-3-215	1		6-3-293	1
	6-3-336	1		6-3-296	1
RCR07G474KS	6-3-324	1	RCR20G471KS	6-3-213	1
RCR07G560KS	6-3-132	1	RCR20G472KS	6-3-387	1
RCR07G562KS	6-6-71	1	RCR20G473KS	6-3-130	1
RCR07G563KS	6-3-98	1		6-3-189	1
RCR20G100KS	6-3-170	1		6-3-345	1
	6-3-281	1		6-3-367	1
RCR20G101KS	6-3-93	1		6-3-410	1
RCR20G102KS	6-3-97A	1	RCR20G474KS	6-3-176	1
	6-3-103	1		6-3-270	1
	6-3-113	1		6-3-274	1
	6-3-126	1		6-3-386	1
	6-3-187	1	RCR20G512JS	6-3-290	1
	6-3-190	1	RCR20G562KS	6-3-98A	1
	6-3-193	1	RCR20G682KS	6-3-120	1
	6-3-208	1		6-3-282	1
	6-3-228	1	RCR20G751JS	6-3-284	1
	6-3-285	1	RCR20G820KS	6-3-115	1
	6-3-292	1	RCR32G102KS	6-3-81	1
	6-3-327	1		6-3-221	1
	6-3-337	1		6-3-341	1
	6-3-340	1		6-5-22	1
	6-3-384	1	RCR32G121KS	6-3-174	1
	6-3-397	1		6-3-269	1
	6-4-2	1	RCR32G153KS	6-3-188	1
	6-4-5	1	RCR32G472KS	6-5-25	1
	6-5-16	1		6-5-27	1
	6-5-18	1		6-5-29	1
	6-6-52	1	RCR32G680KS	6-3-171	1

section 6
parts list

REFERENCE DESIGNATION INDEX

REFERENCE DESIGNATION	FIG - ITEM	PART NUMBER	REFERENCE DESIGNATION	FIG - ITEM	PART NUMBER
RCR32G680KS	6-3-207	1	X201-2	6-3-43	1
RCR42G102KS	6-4-12	1		6-3-44	1
RCR42G223KS	6-3-122	1	X205-2	6-3-38	1
	6-3-223	1	X206-2	6-3-39	1
RCR42G333KS	6-3-210	1		6-3-41	1
	6-3-212	1	X207-2	6-3-35	1
RCR42G393KS	6-3-114	1	X209-2	6-3-11	1
RN55D1782F	6-3-420	1		6-3-13	1
RN55D4221F	6-3-419	1	X269-1	6-3-25	1
RTMT12M	6-3-153A	10	X333-1	6-9-4	1
	6-6-89A	3		6-9-4	1
SI-53184	6-1-17	1		6-9-4	1
SP6P4	6-2-13	3	X334-1	6-9-5	1
SG72CHEMBLK	6-1-24	1		6-9-5	1
S076-4	6-1-22	1		6-9-5	1
SC96CADPL	6-1-21	1	X336-1	6-9-6	1
S289-1587-000	6-3-12	1		6-9-6	1
S418FCHH3P15L02	6-7-53	4		6-9-6	1
TR8169	6-3-432	1	X337-1	6-9-7	1
	6-3-432	1		6-9-7	1
TS0205CC1	6-3-157	1		6-9-7	1
	6-3-300	1	X339-1	6-9-9	1
	6-3-379	1		6-9-9	1
TS102P01	6-3-158	1		6-9-9	1
	6-3-196	1		6-9-10	1
	6-3-196	1		6-9-10	1
	6-3-254	1		6-9-10	1
	6-3-254	1	X340-1	6-9-11	1
	6-3-301	1		6-9-11	1
	6-3-303	1		6-9-11	1
	6-3-303	1		6-9-12	1
	6-3-360	1		6-9-12	1
TS102P02	6-3-196	1	X341-1	6-9-12	1
	6-3-254	1		6-9-13	1
	6-3-303	1		6-9-13	1
TS103P01	6-3-159	1		6-9-13	1
	6-3-199	1		6-9-14	1
	6-3-299	1		6-9-14	1
	6-3-302	1		6-9-14	1
	6-3-302	1		6-9-15	1
	6-3-359	1		6-9-15	1
	6-3-361	1		6-9-15	1
	6-3-381	1		6-9-16	1
	6-3-401	1		6-9-16	1
TS103P02	6-3-159	1	X342-1	6-9-16	1
	6-3-199	1		6-9-17	1
	6-3-302	1		6-9-17	1
TYIICL1-062	6-1-23	1		6-9-17	1
T50411	6-3-58	1	X343-1	6-9-18	1
	6-3-59	1		6-9-18	1
	6-3-60	1		6-9-18	1
	6-3-201	1	X345-1	6-9-19	1
	6-3-237	1		6-9-19	1
	6-3-239	1		6-9-19	1
VY9692	6-3-225	1	X347-1	6-9-22	1
WEE-470	6-3-148	1		6-9-22	1
WR5451	6-3-225	1		6-9-22	1
WR5453	6-3-180	1		6-9-23	1
WR5455	6-3-182	1		6-9-23	1
XA7957	6-3-400	1		6-9-23	1
X188-1	6-3-370	1		6-9-24	1
X189-2	6-6-72	1		6-9-24	1
	6-6-72	1		6-9-24	1

REFERENCE DESIGNATION INDEX

REFERENCE DESIGNATION	FIG - ITEM	PART NUMBER	REFERENCE DESIGNATION	FIG - ITEM	PART NUMBER
X347-1	6-9-25	1	1520A	6-3-362	1
	6-9-25	1		6-4-14	1
	6-9-25	1		6-6-54	1
X348-1	6-9-26	1	1532A	6-5-5	1
	6-9-26	1	1542A	6-5-11	1
	6-9-26	1		6-5-32	1
	6-9-27	1		6-5-49	1
	6-9-27	1		6-5-50	1
	6-9-27	1	1560	6-3-339	1
X349-1	6-9-28	1	163003-0100	6-3-408	1
	6-9-28	1	18-257	6-3-382	1
	6-9-28	1	19C372	6-3-151	i
	6-9-29	1		6-3-191	1
	6-9-29	1		6-3-214	1
	6-9-29	1		6-3-220	1
X350-1	6-9-8	1		6-3-316	1
	6-9-8	1		6-3-334	1
	6-9-8	1	1909	6-3-332	1
X351-1	6-9-20	1	20DD63G104XAA	6-3-205	1
	6-9-20	1		6-3-206	1
	6-9-20	1		6-3-275	1
	6-9-21	1		6-3-298	1
	6-9-21	1	2DDH63N103M	6-3-74	i
	6-9-21	1		6-3-75	1
X352-1	6-9-1	1	2N388	6-3-124	1
	6-9-1	1	2N637B	6-5-42	i
	6-9-1	1		6-5-45	1
	6-9-2	1		6-5-46	1
	6-9-2	1		6-5-48	1
	6-9-2	1	2104-04-01-2520N	6-2-5	2
X364-1	6-3-27	1	210430F1	6-3-430	1
X810-1	6-3-48	1	210874F	6-3-243	1
YE1620F29	6-2-6	2		6-3-246	1
013-570C-000599	6-6-55	5	21C878K1AC	6-3-411	1
015-1622-000	6-7-34	1	211952-187K1	6-3-422	1
024-0100-000	6-1-18	1	212365F	6-7-8	1
1-8SSPALL	6-15-6	4	240-0194-000	6-5-13	1
1N1693	6-5-17	1		6-5-20	1
1N1695	6-4-1	1		6-5-23	1
	6-4-3	1	2540-20-03	6-2-2	1
	6-4-4	1	280-3013-000	6-1-8	1
	6-4-6	1		6-1-8	1
	6-4-7	1		6-1-8	1
	6-4-8	1		6-1-8	1
	6-4-9	1		6-1-8	1
	6-4-11	1	280-3014-000	6-3-37	1
	6-5-8	1	280-3015-000	6-1-8	1
	6-5-9	1		6-1-8	1
1N270	6-3-414	1		6-1-8	1
	6-3-416	1		6-1-8	1
	6-3-417	1		6-1-8	1
	6-3-418	1	280-3421-00	6-3-407	1
1N34A	6-3-141	1	281-0330-000	6-3-403	1
	6-3-142	1	288-2523-000	6-6-10	3
	6-3-143	1	289-1567-00M20	6-14-3	1
	6-3-146	1	289-1568-00M20	6-14-4	1
	6-3-147	1	289-1569-00M20	6-14-5	1
1N482A	6-3-83	1	289-1570-00M20	6-14-6	1
	6-3-313	1	289-1571-00M20	6-14-7	i
1N67A	6-3-89	1	289-1572-C0M20	6-14-8	1
12AX7A	6-3-18	1	289-1573-00M20	6-14-9	1
	6-3-46	1	289-1574-00M20	6-14-10	1
13E	6-3-431	1	289-1575-00M20	6-14-11	1

section 6
parts list

REFERENCE DESIGNATION INDEX

REFERENCE DESIGNATION	FIG - ITEM	PART NUMBER	REFERENCE DESIGNATION	FIG - ITEM	PART NUMBER
289-1576-00M20	6-3-350	1		6-3-80	1
	6-14-12	1		6-3-86	1
289-1577-00M20	6-14-13	1		6-3-91	1
289-1578-00M20	6-14-15	1		6-3-94A	1
289-1579-00M20	6-14-16	1		6-3-99	1
289-1580-00M20	6-14-1	1		6-3-110	1
289-1582-00M20	6-14-14	1		6-3-111	1
289-6996-020M20	6-14-2	1		6-3-116	1
293-0928-000	6-3-65	1		6-3-125	1
3-24	6-1-16	1		6-3-133	1
	6-2-12	1		6-3-149	1
3-858	6-1-16	1		6-3-162	1
	6-2-12	1		6-3-179	1
321035	6-2-9	2		6-3-183	1
3221-201	6-13-1	1		6-3-184	1
	6-13-2	1		6-3-219	1
	6-13-3	1		6-3-229	1
	6-13-4	1		6-3-231	1
	6-13-5	1		6-3-255	1
	6-13-6	1		6-3-256	1
	6-13-7	1		6-3-261	1
	6-13-8	1		6-3-263	1
	6-13-9	1		6-3-264	1
	6-13-10	1		6-3-266	1
	6-13-11	1		6-3-268	1
	6-13-12	1		6-3-272	1
	6-13-13	1		6-3-276	1
	6-13-14	1		6-3-277	1
	6-13-15	1		6-3-278	1
	6-13-16	1		6-3-287	1
	6-13-18	1		6-3-319	1
	6-13-19	1		6-3-335	1
	6-13-20	1		6-3-343	1
	6-13-21	1		6-3-346	1
	6-13-22	1		6-3-348	1
	6-13-23	1		6-3-352	1
	6-13-24	1		6-3-357	1
	6-13-25	1		6-3-368	1
	6-13-26	1		6-3-383	1
	6-13-27	1		6-3-388	1
	6-13-28	1		6-3-390	1
	6-13-29	1		6-3-394	1
33C2	6-3-138	1		6-5-36	1
	6-3-388	1		6-5-38	1
	6-5-7	1		6-5-39	1
	6-5-12	1		6-5-40	1
330-3029-000	6-6-95	24		6-5-41	1
332-1403-165	6-3-378	1		6-5-44	1
34080	6-2-10	1		6-6-53	1
3501FP	6-6-97	1		6-6-75	1
	6-6-98	1	37554	6-4-18	1
	6-6-99	1	37558	6-4-17	1
	6-6-101	1	376-0201-000	6-3-180	1
	6-6-102	1	376-0203-000	6-3-182	1
	6-6-103	1	376-7676-020	6-3-429	1
	6-6-104	1	39003	6-3-248	1
	6-6-105	1	40C73A1	6-3-95	1
	6-6-106	1		6-3-96	1
3501MC	6-1-25	6		6-3-167	1
3505F	6-6-100	1		6-3-177	1
36C175A	6-3-73	1		6-3-338	1
	6-3-76	1		6-3-342	1
	6-3-79	1		6-3-357	1

REFERENCE DESIGNATION INDEX

REFERENCE DESIGNATION	FIG - ITEM	PART NUMBER	REFERENCE DESIGNATION	FIG - ITEM	PART NUMBER
40C73A1	6-3-395	1	541-5983-002	6-3-250	2
41C92	6-3-109	1	541-6503-002	6-15-11	1
	6-3-178	1	541-6506-002	6-15-5	1
	6-3-204	1	541-6532-003	6-3-20	2
	6-3-226	1		6-3-20	7
	6-3-235	1		6-3-23	1
	6-3-389	1	541-6533-003	6-3-8	5
4159-043	6-3-53	1		6-3-8	7
422-04-22-028-11	6-3-56	2		6-3-32	1
3CADP			541-6552-003	6-3-22	1
426-1809-000	6-2-3	1	541-8166-002	6-3-7	5
	6-2-7	1		6-3-7	5
426-1811-000	6-2-8	1		6-3-7	7
44C7A	6-3-152	1	541-8167-002	6-3-31	1
	6-3-258	1	541-8169-002	6-3-19	2
	6-3-308	1		6-3-19	2
	6-3-314	1		6-3-19	7
	6-3-372	1	542-1602-003	6-7-49A	1
	6-3-376	1	543-8039-000	6-3-405	3
4422-4-26	6-3-211	1	543-8101-002	6-1-2	2
	6-3-347	1	543-8116-002	6-1-10	2
	6-3-385	1	544-2844-002	6-3-28A	1
	6-3-396	1	544-3143-002	6-1-6	1
5C11A	6-3-84	1	544-7268-002	6-3-4	1
500-1073-003	6-3-78A	2	544-9692-000	6-3-72	1
	6-7-27	2	546-1296-003	6-3-6	1
	6-7-32	2	546-7109-003	6-6-86	1
500-1126-003	6-7-17A	2	547-2521-002	6-6-17	2
500-1128-003	6-6-94	24	547-2523-002	6-6-15	1
502-1427-002	6-3-154	1	547-2524-002	6-6-18	1
	6-3-197	1	547-2525-002	6-6-13	2
	6-3-200	1	547-2526-002	6-6-12A	4
	6-3-253	1	547-2527-002	6-6-7	1
	6-3-317	1	547-2528-002	6-6-6	1
503-2604-001	6-1-10	2	547-2529-002	6-6-4	1
504-0717-003	6-7-37A	1	547-2530-002	6-6-24	1
504-7537-002	6-7-45	1	547-2531-002	6-6-110	1
504-7576-002	6-6-22	1	547-2537-002	6-7-16	1
504-8229-001	6-3-11A	2	547-2539-002	6-7-23	1
506-3189-002	6-7-9	1	547-2541-002	6-7-14	1
522-2245-000	6-1-	1	547-2543-002	6-7-17	1
522-2245-030	6-1-	1	547-2548-002	6-7-42	1
522-2498-000	6-1-	1	547-2552-002	6-7-39	1
522-2498-030	6-1-	1	547-2553-002	6-7-37	2
522-2546-000	6-1-	1	547-2554-002	6-7-12	1
522-2546-030	6-1-	1	547-2556-002	6-7-4	1
522-2918-000	6-3-50	1		6-7-22	1
522-3156-000	6-1-	1	547-2557-002	6-7-40	1
522-3156-030	6-1-	1	547-2558-002	6-7-13	1
522-3857-001	6-1-	1	547-2559-002	6-7-1	1
522-3970-001	6-1-28	1	547-2560-002	6-7-24	1
	6-15-	REF	547-2561-002	6-7-26	1
526-9414-000	6-3-68	1		6-7-31	1
526-9415-000	6-3-69	1	547-2563-002	6-7-46	1
526-9422-000	6-3-68	1	547-2564-002	6-6-89	1
526-9423-000	6-3-69	1	547-2565-002	6-6-3	1
540-9045-003	6-6-40	2	547-2566-002	6-6-4A	1
540-9053-003	6-6-56	6	547-2572-002	6-7-7	1
540-9054-003	6-3-66	2	547-2574-002	6-7-2	1
540-9181-003	6-3-428	1	547-2575-002	6-7-51	7
541-1200-003	6-7-23A	AR	547-2576-002	6-7-6	1
541-1237-003	6-7-23B	AR	547-2577-002	6-7-30	1
541-5181-002	6-3-71	1	547-2578-002	6-7-15	1

section 6
parts list

REFERENCE DESIGNATION INDEX

REFERENCE DESIGNATION	FIG - ITEM	PART NUMBER	REFERENCE DESIGNATION	FIG - ITEM	PART NUMBER
547-2579-002	6-7-25	1		6-6-34	1
547-2580-002	6-6-38	12	547-2664-004	6-6-96	1
547-2584-002	6-7-11	1	547-2670-004	6-10-8	1
547-2585-002	6-7-28	1	547-2672-004	6-14-18	1
547-2586-002	6-6-23	1	547-2673-000	6-3-406	1
547-2589-002	6-6-57	1	547-2676-004	6-8-26	1
547-2590-002	6-7-43	1		6-11-26	1
547-2592-002	6-7-10	1	547-2677-004	6-6-37	1
547-2593-002	6-7-29	1		6-14-	REF
547-2594-002	6-6-14	2	547-2679-004	6-12-29	1
547-2595-002	6-7-33	1	547-2680-004	6-6-26	1
547-2598-002	6-7-38	1		6-6-29	1
547-2600-002	6-7-37	2		6-8-	REF
547-2601-002	6-7-35	1		6-8-	REF
547-2602-002	6-7-1	3	547-2681-004	6-6-35	1
547-2603-003	6-1-13A	1		6-12-	REF
	6-1-13A	1	547-2682-004	6-6-28	1
	6-1-13A	1		6-10-	REF
	6-1-13A	1	547-2683-004	6-7-54	1
	6-1-13A	1	547-2684-004	6-6-108	1
	6-6-1	1	547-2685-004	6-6-27	1
547-2604-003	6-6-8	1		6-6-30	1
547-2605-003	6-6-9	1		6-6-31	1
547-2606-003	6-7-49	1		6-9-	REF
547-2607-003	6-7-48	1		6-9-	1
547-2611-003	6-6-63	1		6-9-	1
547-2612-003	6-6-61	1	547-2690-004	6-13-30	1
547-2613-003	6-6-62	2	547-2691-004	6-6-36	1
547-2614-003	6-6-88	1		6-13-	REF
547-2615-003	6-7-5	1	547-2692-000	6-3-72B	1
547-2617-003	6-10-6	1		6-6-	REF
547-2618-003	6-10-1	1	547-2693-000	6-3-34	1
	6-10-7	1		6-4-	REF
547-2619-003	6-10-5	1	547-2694-005	6-6-12	1
547-2620-003	6-6-60	1		6-7-	REF
547-2621-003	6-6-39	1	547-2698-002	6-3-247	1
547-2622-003	6-14-17	1	547-2699-002	6-3-244	1
547-2623-003	6-7-19	1	547-2715-003	6-7-41	1
547-2624-003	6-6-41	1	547-2716-003	6-6-68	3
	6-6-43	1	547-2717-003	6-6-59	1
	6-6-44	1	547-2724-003	6-6-64	1
547-2625-003	6-6-77	1	547-2728-004	6-3-439	1
	6-6-80	1	547-2742-006	6-1-9	1
	6-6-83	1	547-2743-003	6-3-424	1
547-2626-003	6-6-16	1	547-2744-004	6-3-423	1
547-2628-002	6-3-245	1	547-2747-003	6-6-65	1
547-2629-002	6-3-249	1	547-2748-003	6-6-67	3
547-2630-002	6-3-54	1	547-2749-003	6-6-66	2
547-2634-002	6-3-435	1	547-2750-003	6-6-69	2
547-2635-002	6-3-436	2	547-2757-000	6-3-72B	1
547-2637-002	6-3-433	1	547-2768-002	6-3-49	1
547-2638-002	6-3-242	1	547-2770-002	6-3-51	1
547-2642-002	6-3-64	1	547-2791-000	6-1-27	1
547-2643-002	6-3-437	1		6-1-27	1
547-2644-002	6-6-87	3		6-3-	REF
547-2645-002	6-3-5	1	547-2791-001	6-1-27	1
547-2647-003	6-3-70	1		6-3-	REF
547-2649-003	6-3-42	1	547-2791-018	6-1-27	1
547-2650-003	6-7-44	1		6-3-	REF
547-2651-003	6-6-58	1	547-2795-000	6-1-14	1
547-2652-003	6-1-11A	1	547-2796-002	6-1-13	1
	6-3-72A	1	547-2810-002	6-7-52	1
547-2661-004	6-6-33	1	547-2811-002	6-6-2	1

REFERENCE DESIGNATION INDEX

REFERENCE DESIGNATION	FIG - ITEM	PART NUMBER	REFERENCE DESIGNATION	FIG - ITEM	PART NUMBER
547-2813-004	6-9-30		6H12	6-3-155	1
547-3738-000	6-7-20	1		6-3-156	1
547-3739-002	6-6-109	1		6-3-160	1
547-3930-000	6-3-34	1		6-3-161	1
	6-5-	REF		6-3-198	1
547-5967-002	6-7-9A	2		6-3-251	1
548-1322-005	6-1-11	1		6-3-252	1
548-1323-004	6-1-12	1		6-3-304	1
548-1327-002	6-1-7	1		6-3-305	1
	6-1-7	1		6-3-402	1
	6-1-7	1		6-4-10	1
548-1334-002	6-3-67	2		6-5-30	1
548-1335-002	6-3-63	1		6-5-31	1
548-1347-002	6-3-55	1	606-9739-001	6-7-16	1
548-1410-000	6-6-90	1	606-9740-000	6-6-25	1
548-8200-002	6-6-93	24	609-0573-001	6-1-10	1
548-8243-004	6-3-2	1		6-1-12	1
548-8244-000	6-3-3	1	609-1067-001	6-3-434	1
548-8245-000	6-1-14	1	609-1241-001	6-9-4	1
549-0211-000	6-3-72B	1		6-9-4	1
549-0212-000	6-1-27	1		6-9-4	1
	6-3-	REF	609-1242-001	6-9-5	1
549-0212-006	6-1-27	1		6-9-5	1
	6-3-	REF		6-9-5	1
549-0216-003	6-5-1	1	609-1243-001	6-9-6	1
549-0217-003	6-5-37	1		6-9-6	1
549-0312-000	6-5-35	1		6-9-6	1
549-0630-004	6-6-32	1		6-9-7	1
	6-11-	REF		6-9-7	1
549-4441-002	6-7-3	1		6-9-7	1
55C23A2	6-3-131	1	609-1244-001	6-9-8	1
553-5787-003	6-1-10A	1		6-9-8	1
553-9532-000	6-5-51	1		6-9-8	1
554-4423-001	6-15-1	1		6-9-9	1
554-4493-001	6-1-4	2		6-9-9	1
557-018-3-12A	6-6-19	1		6-9-9	1
557-018-5-25A	6-3-295	1		6-9-10	1
	6-3-358	1		6-9-10	1
557006C0P039R	6-3-295	1		6-9-10	1
	6-3-358	1		6-9-11	1
	6-3-380	1		6-9-11	1
	6-6-20	1		6-9-11	1
	6-6-21	1	609-1245-001	6-9-12	1
	6-6-76	1		6-9-12	1
557C06U2P034R	6-6-42	1		6-9-12	1
	6-6-45	1		6-9-13	1
	6-6-46	1		6-9-13	1
5670	6-3-33	1		6-9-13	1
57-634-7	6-6-11	3		6-9-14	1
599-2004-5	6-6-107	1		6-9-14	1
599C2004-5	6-6-107	1		6-9-14	1
6AK6	6-3-15	1		6-9-15	1
6BA6	6-3-36	1		6-9-15	1
	6-3-40	1		6-9-15	1
	6-3-45	1		6-9-16	1
	6-3-47	1		6-9-16	1
6BF5	6-3-24	1		6-9-16	1
6DC6	6-3-21	1		6-9-17	1
6EAB	6-3-9	1		6-9-17	1
	6-3-10	1		6-9-17	1
	6-3-16	1		6-9-18	1
	6-3-26	1		6-9-18	1
	6-3-29	1		6-9-18	1

section 6
parts list

REFERENCE DESIGNATION INDEX

REFERENCE DESIGNATION	FIG - ITEM	PART NUMBER	REFERENCE DESIGNATION	FIG - ITEM	PART NUMBER		
609-1246-001	6-9-19	1	767-6254-001	6-1-5	1		
	6-9-19	1		6-2-	REF		
	6-9-19	1		6-1-9	1		
	6-9-20	1		767-6255-001	6-15-3	1	
	6-9-20	1		767-6256-001	6-15-2	4	
	6-9-20	1		770-9G	6-1-15	1	
	6-9-21	1		78S9M1001	6-2-11	1	
	6-9-21	1		81118203C0G0-309 C	6-9-3	1	
	6-9-21	1			6-9-3	1	
	6-9-22	1			6-9-3	1	
	6-9-22	1		841-000X5V0223Z	6-3-138	1	
	6-9-22	1			6-3-393	1	
	6-9-23	1			6-3-78	1	
	6-9-23	1		86CP9-1003	6-3-243A	2	
	6-9-23	1		8980-2 1-2	6-3-224	4	
	6-9-24	1		905	6-6-89B	8	
	6-9-24	1		911	6-5-43	1	
	6-9-24	1			6-3-14	1	
	6-9-25	1			956-0614-410		
	6-9-25	1					
	6-9-25	1					
	609-1247-001	6-9-1		1			
		6-9-1		1			
		6-9-1		1			
		6-9-2		1			
		6-9-2		1			
		6-9-2		1			
		6-9-26		1			
		6-9-26		1			
		6-9-26		1			
6-9-27		1					
6-9-27		1					
6-9-27		1					
6-9-28		1					
6-9-28		1					
6-9-28		1					
6-9-29		1					
6-9-29		1					
6-9-29		1					
6-3-77		1					
61-61							
618-4921-027	6-3-124	1					
664-1020-000	6-5-2	1					
747RBLACK	6-1-1	4					
7543	6-3-30	1					
756-0480-001	6-6-5	2					
	6-7-18	2					
756-2335-002	6-3-404	1					
756-3002-004	6-4-21	1					
756-4050-002	6-7-47	2					
757-2839-001	6-7-28A	AR					
757-3933-001	6-15-8	1					
757-3934-001	6-15-9	1					
757-3935-001	6-15-10	1					
757-3936-001	6-15-12	1					
757-3937-001	6-15-7	4					
757-4190-001	6-15-4	2					
757-8610-001	6-3-427	1					
757-8613-001	6-3-426	1					
757-8614-001	6-3-425	1					
761-5912-001	6-1-7	1					
	6-1-7	1					
761-5916-001	6-2-14	1					
767-6252-001	6-1-3	1					

6.4 REFERENCE DESIGNATION INDEX

REFERENCE DESIGNATION	FIG - ITEM	PART NUMBER	REFERENCE DESIGNATION	FIG - ITEM	PART NUMBER
A1	6-6-26	547-2680-004	A2L15	6-9-17	609-1245-001
A1	6-8-	547-2690-004	A2L15	6-9-17	X342-1
A1C11A	6-8-21	DM15F511G300WV4C R	A2L16	6-9-18	X343-1
A1C11B	6-8-22	CM05FD331G03	A2L16	6-9-18	609-1245-001
A1C12	6-8-23	DM15F431G300WV4C R	A2L17	6-9-19	X345-1
A1C13	6-8-24	CM05FD301G03	A2L17	6-9-19	609-1246-001
A1C14	6-8-25	DM15E2520G0500WV 4CR	A2L18	6-9-20	609-1246-001
A1C15	6-8-1	CM05FD201G03	A2L18	6-9-20	X351-1
A1C16	6-8-2	CM05FD181G03	A2L19	6-9-21	X351-1
A1C17	6-8-3	CM05FD151G03	A2L19	6-9-21	609-1246-001
A1C18	6-8-4	CM05FD131G03	A2L2	6-9-4	609-1241-001
A1C19	6-8-5	CM05FD111G03	A2L2	6-9-4	X333-1
A1C20	6-8-6	CM05FD101G03	A2L20	6-9-22	609-1246-001
A1C21	6-8-7	CM05FD910G03	A2L20	6-9-22	X347-1
A1C22	6-8-8	CM05ED920G03	A2L21	6-9-23	609-1246-001
A1C23	6-8-9	CM05ED680G03	A2L21	6-9-23	X347-1
A1C24	6-8-10	CM05ED620G03	A2L22	6-9-24	X347-1
A1C25	6-8-11	CM05ED560G03	A2L22	6-9-24	609-1246-001
A1C27	6-8-12	CM05ED510G03	A2L23	6-9-25	X347-1
A1C28	6-8-13	CM05ED430G03	A2L23	6-9-25	609-1246-001
A1C30	6-8-14	CM05FD330G03	A2L24	6-9-26	X348-1
A1C31	6-8-15	CM05FD240J03	A2L24	6-9-26	609-1247-001
A1C32	6-8-16	CM05ED200J03	A2L25	6-9-27	X348-1
A1C34	6-8-17	CM05CD150J03	A2L25	6-9-27	609-1247-001
A1C35	6-8-18	CM05CD180J03	A2L26	6-9-28	609-1247-001
A1C37	6-8-19	CM05CD150J03	A2L26	6-9-28	X349-1
A1C38	6-8-20	CM05CD120J03	A2L27	6-9-29	X349-1
A10	6-6-37	547-2677-004	A2L27	6-9-29	609-1247-001
A10	6-14-	547-2677-004	A2L28	6-9-1	X352-1
A10Y1	6-14-3	289-1567-00M20	A2L28	6-9-1	609-1247-001
A10Y10	6-14-12	289-1576-00M20	A2L29	6-9-2	X352-1
A10Y11	6-14-13	289-1577-00M20	A2L29	6-9-2	609-1247-001
A10Y12	6-14-14	289-1582-00M20	A2L3	6-9-5	609-1242-001
A10Y13	6-14-15	289-1578-00M20	A2L3	6-9-5	X334-1
A10Y18	6-14-16	289-1579-00M20	A2L4	6-9-6	X336-1
A10Y19	6-14-1	289-1580-00M20	A2L4	6-9-6	609-1243-001
A10Y2	6-14-4	289-1568-00M20	A2L5	6-9-7	X337-1
A10Y20	6-14-2	289-6996-020M20	A2L5	6-9-7	609-1243-001
A10Y3	6-14-5	289-1569-00M20	A2L6	6-9-8	X350-1
A10Y4	6-14-6	289-1570-00M20	A2L6	6-9-8	609-1244-001
A10Y5	6-14-7	289-1571-00M20	A2L7	6-9-9	X339-1
A10Y6	6-14-8	289-1572-00M20	A2L7	6-9-9	609-1244-001
A10Y7	6-14-9	289-1573-00M20	A2L8	6-9-10	X339-1
A10Y8	6-14-10	289-1574-00M20	A2L8	6-9-10	609-1244-001
A10Y9	6-14-11	289-1575-00M20	A2L9	6-9-11	X340-1
A11	6-7-36	I145100	A2L9	6-9-11	609-1244-001
A2	6-6-27	547-2685-004	A3	6-6-28	547-2682-004
A2	6-9-	547-2685-004	A3	6-10-	547-2682-004
A2C326	6-9-3	8111R203COG0-309 C	A3L110	6-10-2	MS75008-35
A2L10	6-9-12	X340-1	A3L110	6-10-2	MS75101-2
A2L10	6-9-12	609-1245-001	A3L111	6-10-3	LT4K036
A2L11	6-9-13	X341-1	A3L111	6-10-3	MS75008-30
A2L11	6-9-13	609-1245-001	A3L34	6-10-4	LT4K034
A2L12	6-9-14	X341-1	A3L34	6-10-4	MS75008-28
A2L12	6-9-14	609-1245-001	A3L35	6-10-5	547-2619-003
A2L13	6-9-15	X341-1	A3L36	6-10-6	547-2617-003
A2L13	6-9-15	609-1245-001	A3L37	6-10-7	547-2618-003
A2L14	6-9-16	609-1245-001	A3L38	6-10-1	547-2618-003
A2L14	6-9-16	X341-1	A4	6-6-29	547-2680-004
			A4	6-8-	547-2680-004
			A4C41A	6-8-21	DM15F511G300WV4C R
			A4C41B	6-8-22	CM05FD331G03

REFERENCE DESIGNATION INDEX

REFERENCE DESIGNATION	FIG - ITEM	PART NUMBER	REFERENCE DESIGNATION	FIG - ITEM	PART NUMBER
A4C42	6-8-23	DM15F431G3CCWV4C R	A5L56	6-9-21	609-1246-001
A4C43	6-8-24	CM05FD301G03	A5L56	6-9-21	X351-1
A4C44	6-8-25	DM15E2520G050GWV 4CR	A5L57	6-9-22	X347-1
A4C45	6-8-1	CM05FD201G03	A5L57	6-9-22	609-1246-001
A4C46	6-8-2	CM05FD181G03	A5L58	6-9-23	609-1246-001
A4C47	6-8-3	CM05FD151G03	A5L58	6-9-23	X347-1
A4C48	6-8-4	CM05FD131G03	A5L59	6-9-24	X347-1
A4C49	6-8-5	CM05FD111G03	A5L59	6-9-24	609-1246-001
A4C50	6-8-6	CM05FD101G03	A5L60	6-9-25	609-1246-001
A4C51	6-8-7	CM05FD091G03	A5L60	6-9-25	X347-1
A4C52	6-8-8	CM05ED820G03	A5L61	6-9-26	609-1247-001
A4C53	6-8-9	CM05FD0680G03	A5L61	6-9-26	X348-1
A4C54	6-8-10	CM05ED620G03	A5L62	6-9-27	609-1247-001
A4C55	6-8-11	CM05FD0560G03	A5L62	6-9-27	X348-1
A4C57	6-8-12	CM05ED0510G03	A5L63	6-9-28	609-1247-001
A4C58	6-8-13	CM05FD0430G03	A5L63	6-9-28	X349-1
A4C60	6-8-14	CM05ED0330G03	A5L64	6-9-29	X349-1
A4C61	6-8-15	CM05ED0240J03	A5L64	6-9-29	609-1247-001
A4C62	6-8-16	CM05ED200J03	A5L65	6-9-1	609-1247-001
A4C64	6-8-17	CM05CD150J03	A5L65	6-9-1	X352-1
A4C65	6-8-18	CM05CD180J03	A5L66	6-9-2	X352-1
A4C67	6-8-19	CM05CD150J03	A5L66	6-9-2	609-1247-001
A4C68	6-8-20	CM05CD120J03	A6	6-6-31	547-2685-004
A5	6-6-30	547-2685-004	A6	6-9-	547-2685-004
A5	6-9-	547-2685-004	A6C328	6-9-3	81118203C0G0-309 C
A5C327	6-9-3	81118203C0G0-309 C	A6L100	6-9-1	X352-1
A5L39	6-9-4	609-1241-001	A6L100	6-9-1	609-1247-001
A5L39	6-9-4	X333-1	A6L101	6-9-2	X352-1
A5L40	6-9-5	609-1242-001	A6L101	6-9-2	609-1247-001
A5L40	6-9-5	X334-1	A6L74	6-9-4	X333-1
A5L41	6-9-6	X336-1	A6L74	6-9-4	609-1241-001
A5L41	6-9-6	609-1243-001	A6L75	6-9-5	609-1242-001
A5L42	6-9-7	609-1243-001	A6L75	6-9-5	X334-1
A5L42	6-9-7	X337-1	A6L76	6-9-6	X336-1
A5L43	6-9-8	X350-1	A6L76	6-9-6	609-1243-001
A5L43	6-9-8	609-1244-001	A6L77	6-9-7	X337-1
A5L44	6-9-9	609-1244-001	A6L77	6-9-7	609-1243-001
A5L44	6-9-9	X339-1	A6L78	6-9-8	609-1244-001
A5L45	6-9-10	X339-1	A6L78	6-9-8	X350-1
A5L45	6-9-10	609-1244-001	A6L79	6-9-9	609-1244-001
A5L46	6-9-11	X340-1	A6L79	6-9-9	X339-1
A5L46	6-9-11	609-1244-001	A6L80	6-9-10	X339-1
A5L47	6-9-12	609-1245-001	A6L80	6-9-10	609-1244-001
A5L47	6-9-12	X340-1	A6L81	6-9-11	609-1244-001
A5L48	6-9-13	X341-1	A6L81	6-9-11	X340-1
A5L48	6-9-13	609-1245-001	A6L82	6-9-12	609-1245-001
A5L49	6-9-14	X341-1	A6L82	6-9-12	X340-1
A5L49	6-9-14	609-1245-001	A6L83	6-9-13	609-1245-001
A5L50	6-9-15	609-1245-001	A6L83	6-9-13	X341-1
A5L50	6-9-15	X341-1	A6L84	6-9-14	X341-1
A5L51	6-9-16	X341-1	A6L84	6-9-14	609-1245-001
A5L51	6-9-16	609-1245-001	A6L85	6-9-15	X341-1
A5L52	6-9-17	X342-1	A6L85	6-9-15	609-1245-001
A5L52	6-9-17	609-1245-001	A6L86	6-9-16	X341-1
A5L53	6-9-18	X343-1	A6L86	6-9-16	609-1245-001
A5L53	6-9-18	609-1245-001	A6L87	6-9-17	X342-1
A5L54	6-9-19	X345-1	A6L87	6-9-17	609-1245-001
A5L54	6-9-19	609-1246-001	A6L88	6-9-18	609-1245-001
A5L55	6-9-20	X351-1	A6L88	6-9-18	X343-1
A5L55	6-9-20	609-1246-001	A6L89	6-9-19	X345-1
			A6L89	6-9-19	609-1246-001
			A6L90	6-9-20	X351-1

REFERENCE DESIGNATION INDEX

REFERENCE DESIGNATION	FIG - ITEM	PART NUMBER	REFERENCE DESIGNATION	FIG - ITEM	PART NUMBER
A6L90	6-9-20	609-1246-001	A8C210	6-12-16	DM15E1140G0500WV 4CR
A6L91	6-9-21	X351-1	A8C211	6-12-17	CM05FD101G03
A6L91	6-9-21	609-1246-001	A8C212	6-12-18	CM05ED820G03
A6L92	6-9-22	609-1246-001	A8C213	6-12-19	DM15E710G0500WV4 CR
A6L92	6-9-22	X347-1	A8C214	6-12-20	CM05ED620G03
A6L93	6-9-23	609-1246-001	A8C215	6-12-21	CM05ED510G03
A6L93	6-9-23	X347-1	A8C216	6-12-22	CM05ED430G03
A6L94	6-9-24	609-1246-001	A8C217	6-12-23	CM05ED360G03
A6L94	6-9-24	X347-1	A8C218	6-12-24	CM05ED300G03
A6L95	6-9-25	X347-1	A8C239	6-12-25	DM15E240K500WV4C R
A6L95	6-9-25	609-1246-001	A8C240	6-12-26	CM05ED200J03
A6L96	6-9-26	X348-1	A8C241	6-12-27	CM05CD150J03
A6L96	6-9-26	609-1247-001	A8C242	6-12-28	CM05CD120J03
A6L97	6-9-27	609-1247-001	A8C243	6-12-1	QC8-2UUF5PCT
A6L97	6-9-27	X348-1	A8C244	6-12-2	QC4-7UUF5PCT
A6L98	6-9-28	609-1247-001	A8C245	6-12-3	QC1-1UUF5PCT
A6L98	6-9-28	X349-1	A9	6-6-36	547-2691-004
A6L99	6-9-29	X349-1	A9	6-13-	547-2691-004
A6L99	6-9-29	609-1247-001	A9C276	6-13-17	QC5-1UUF5PCT
A7	6-6-32	549-0630-004	A9C277	6-13-3	3221-201
A7	6-11-	549-0630-004	A9C278	6-13-4	3221-201
A7C101	6-11-18	CM05CD150J03	A9C279	6-13-5	3221-201
A7C102	6-11-19	CM05CD120J03	A9C280	6-13-6	3221-201
A7C75A	6-11-20	DM15F511G300WV4C R	A9C281	6-13-7	3221-201
A7C75B	6-11-21	CM05FD331G03	A9C282	6-13-8	3221-201
A7C76	6-11-22	DM15F4350F300WV4 CR	A9C283	6-13-9	3221-201
A7C77	6-11-23	CM05FD331G03	A9C284	6-13-10	3221-201
A7C78	6-11-24	DM15E2520G0500WV 4CR	A9C285	6-13-11	3221-201
A7C79	6-11-25	CM05FD221G03	A9C286	6-13-12	3221-201
A7C80	6-11-1	CM05FD181G03	A9C287	6-13-13	3221-201
A7C81	6-11-2	CM05FD151G03	A9C288	6-13-14	3221-201
A7C82	6-11-3	CM05FD131G03	A9C289	6-13-15	3221-201
A7C83	6-11-4	CM05FD111G03	A9C290	6-13-16	3221-201
A7C84	6-11-5	CM05FD101G03	A9C291	6-13-18	3221-201
A7C85	6-11-6	CM05FD910G03	A9C292	6-13-19	3221-201
A7C86	6-11-7	CM05ED820G03	A9C293	6-13-20	3221-201
A7C87	6-11-8	CM05ED680G03	A9C294	6-13-21	3221-201
A7C88	6-11-9	CM05ED620G03	A9C295	6-13-22	3221-201
A7C89	6-11-10	CM05ED560G03	A9C296	6-13-23	3221-201
A7C91	6-11-11	CM05ED510G03	A9C297	6-13-24	3221-201
A7C92	6-11-12	CM05ED430G03	A9C298	6-13-25	3221-201
A7C94	6-11-13	CM05FD330G03	A9C299	6-13-26	3221-201
A7C95	6-11-14	CM05ED240J03	A9C300	6-13-27	3221-201
A7C96	6-11-15	CM05FD200J03	A9C301	6-13-28	3221-201
A7C98	6-11-16	CM05CD150J03	A9C302	6-13-29	3221-201
A7C99	6-11-17	CM05CD180J03	A9C303	6-13-1	3221-201
A8	6-6-35	547-2681-004	A9C304	6-13-2	3221-201
A8	6-12-	547-2681-004	CR1	6-3-146	1N34A
A8C198	6-12-4	CM05ED560G03	CR10	6-4-6	1N1695
A8C199	6-12-5	CM05ED680G03	CR11	6-4-8	1N1695
A8C200	6-12-6	CM05FD910G03	CR12	6-4-7	1N1695
A8C201	6-12-7	CM05FD121G03	CR13	6-4-9	1N1695
A8C202	6-12-8	CM05FD161G03	CR14	6-3-83	1N482A
A8C203	6-12-9	CM05FD111G03	CR15	6-3-147	1N34A
A8C204	6-12-10	CM05ED820G03	CR16	6-3-313	1N482A
A8C205	6-12-11	CM05FD620G03	CR17	6-3-89	1N67A
A8C206	6-12-12	CM05FD510G03	CR18	6-3-416	1N270
A8C207	6-12-13	CM05ED360G03	CR19	6-3-418	1N270
A8C208	6-12-14	CM05ED270G03	CR2	6-3-141	1N34A
A8C209	6-12-15	CM05ED200J03	CR20	6-3-417	1N270

REFERENCE DESIGNATION INDEX

REFERENCE DESIGNATION	FIG - ITEM	PART NUMBER	REFERENCE DESIGNATION	FIG - ITEM	PART NUMBER
CR3	6-3-142	1N34A	C170	6-3-368	36C175A
CR4	6-3-143	1N34A	C171	6-3-277	36C175A
CR401	6-5-8	1N1695	C172	6-3-111	36C175A
CR402	6-5-9	1N1695	C173	6-3-286	CM05FD331J03
CR403	6-5-17	1N1693	C174	6-3-76	36C175A
CR5	6-3-414	1N27C	C175	6-3-73	36C175A
CR6	6-4-4	1N1695	C176	6-3-90	D31536
CR7	6-4-1	1N1695	C177	6-3-276	36C175A
CR8	6-4-11	1N1695	C178	6-3-278	36C175A
CR9	6-4-3	1N1695	C179	6-3-194	CM05ED390J03
C1	6-3-330	CC20CK010C	C180	6-3-74	2DDH63N103M
C10	6-3-204	41C92	C181	6-3-75	2DDH63N103M
C103	6-3-321	CM05FD220J03	C182	6-4-16	D33257
C104	6-3-328	CC20CK010C	C183	6-4-15	D29238
C105	6-3-343	36C175A	C185	6-3-110	36C175A
C106	6-3-335	36C175A	C186	6-3-79	36C175A
C111	6-3-333	CC20CK020C	C187	6-3-80	36C175A
C112	6-3-376	44C7A	C190	6-3-116	36C175A
C113	6-6-46	557006U2P034R	C191	6-3-264	36C175A
C114	6-6-53	36C175A	C192	6-3-84	5C11A
C115	6-6-47	CM05FD361G03	C193	6-3-389	41C92
C116	6-6-48	CM05CD100D03	C194	6-3-268	36C175A
C117	6-6-42	557006U2P034R	C195	6-3-219	36C175A
C118	6-6-51	CM05FD391G03	C196	6-3-364	CM05ED200J03
C119	6-6-49	CM05CD050D03	C197	6-3-325	CM04ED680J03
C120	6-6-45	557006U2P034R	C2	6-3-358	557006C0P039R
C121	6-6-50	CM05FD391G03	C2	6-3-358	557-J18-5-25A
C122	6-3-383	36C175A	C219	6-6-75	36C175A
C123	6-3-394	36C175A	C220	6-3-108	DM15C15GK500WV4C R
C124	6-3-319	36C175A	C221	6-3-109	41C92
C125	6-3-395	40C73A1	C222	6-3-105	DM15F101K500WV4C R
C127	6-3-62	CM05ED510G03	C223	6-3-298	2000636104XAA
C127	6-3-203	CM05ED510G03	C224	6-3-102	DM15F471J300WV4C R
C128	6-3-61	CM05FD510G03	C224	6-3-102	CM05FD391J03
C129	6-3-57	CM05ED510G03	C225	6-3-99	36C175A
C130	6-3-202	CM05ED620G03	C226	6-3-94A	36C175A
C130	6-3-236	CM05ED620G03	C227	6-3-295	557006C0P039R
C131	6-3-241	CM05FD620G03	C227	6-3-295	557-J18-5-25A
C132	6-3-240	CM05ED620G03	C228	6-3-294	CM05CD100D03
C134	6-3-165	CC20CJ030D	C229	6-3-256	36C175A
C137	6-3-220	19C372	C230	6-3-260	DM15F101K500WV4C R
C138	6-3-214	19C372	C231	6-3-263	36C175A
C140	6-3-231	36C175A	C232	6-3-306	CC20CK010D
C143	6-3-178	41C92	C233	6-3-380	557006C0P039R
C144	6-3-167	40C73A1	C234	6-3-366	CM05CD100D03
C147	6-3-177	40C73A1	C235	6-3-375	DM15F101K500WV4C R
C148	6-3-191	19C372	C236	6-3-372	44C7A
C149	6-3-179	36C175A	C237	6-3-369	CM05ED470J03
C150	6-3-183	36C175A	C246	6-6-76	557006C0P039R
C153	6-3-164	CM05FD121J03	C247	6-4-13	D29238
C154	6-3-95	40C73A1	C249	6-3-117	R41283-47-40
C155	6-3-162	36C175A	C250	6-3-287	36C175A
C156	6-3-125	36C175A	C251	6-3-390	36C175A
C158	6-3-127	CM05ED470J03	C252	6-3-266	36C175A
C161	6-3-138	841-000X5V0223Z	C253	6-3-421	R41283-47-40
C161	6-3-138	33C2	C254	6-3-393	841-J00X5V0223Z
C162	6-3-136	D33212	C255	6-3-388	36C175A
C163	6-3-151	19C372	C255	6-3-388	33C2
C164	6-3-149	36C175A			
C165	6-3-131	55C23A2			
C167	6-3-280	R41283-47-40			
C168	6-3-261	36C175A			
C169	6-3-272	36C175A			

REFERENCE DESIGNATION INDEX

REFERENCE DESIGNATION	FIG - ITEM	PART NUMBER	REFERENCE DESIGNATION	FIG - ITEM	PART NUMBER
C256	6-3-201	T50411	FL2	6-3-69	526-9423-000
C257	6-3-239	T50411	FL2	6-3-69	526-9415-000
C258	6-3-237	T50411	FL3	6-3-68	526-9414-000
C259	6-3-59	T50411	FL3	6-3-68	526-9422-000
C260	6-3-60	T50411	FL4	6-3-65	293-0928-000
C261	6-3-58	T50411	F1	6-4-19	F02B250V1 1-2AS
C262	6-3-273	841283-47-40	F401	6-5-33	F02A250V6AS
C263	6-3-357	36C175A	J1	6-6-100	3505F
C263	6-3-357	40C73A1	J10	6-3-78	86CP9-1003
C264	6-3-205	20DD63G104XAA	J101	6-2-4	MS3112E12-10P
C265	6-3-206	20DD63G104XAA	J102	6-2-1	M39012-21-0001
C266	6-3-398	DM15F471J300WV4C R	J11	6-6-106	3501FP
C269	6-3-289	D31536	J12	6-6-102	3501FP
C270	6-3-334	19C372	J13	6-6-98	3501FP
C271	6-3-91	36C175A	J14	6-6-99	3501FP
C272	6-3-133	36C175A	J16	6-3-431	13E
C275	6-3-86	36C175A	J4	6-6-97	3501FP
C3	6-3-309	CM05FD101G03	J5	6-6-101	3501FP
C306	6-3-356	CM04CD100003	J6	6-3-400	XA7907
C307	6-3-226	41C92	J7	6-6-103	3501FP
C308	6-3-232	CC20CK020C	J8	6-6-104	3501FP
C309	6-3-192	CC20CK020C	J9	6-6-105	3501FP
C310	6-3-152	44C7A	L1	6-3-354	MS90539-15
C311	6-3-112	CM05FD331J03	L102	6-6-41	547-2624-003
C312	6-3-275	20DD63G104XAA	L103	6-6-43	547-2624-003
C316	6-3-106	D29343	L104	6-6-44	547-2624-003
C318	6-3-346	36C175A	L105	6-3-382	18-257
C319	6-3-153	CM05FD331J03	L106	6-3-169	MS90539-15
C320	6-3-184	36C175A	L108	6-3-48	X810-1
C321	6-3-275A	QC5-1UUF5PCT	L109	6-4-18	37554
C322	6-3-352	36C175A	L112	6-6-73	MS90539-15
C323	6-3-255	36C175A	L113	6-3-377	BS217
C324	6-3-338	40C73A1	L113	6-3-377	MS90538-20
C325	6-3-229	36C175A	L114	6-3-139	BS217
C326	6-3-96	40C73A1	L114	6-3-139	MS75089-15
C327	6-3-438	CM05FD101J03	L115	6-3-311	BS217
C39	6-3-310	CM05ED470J03	L115	6-3-311	MS90538-20
C4	6-3-308	44C7A	L116	6-3-347	4422-4-26
C40	6-6-19	557-018-3-12A	L117	6-3-396	4422-4-26
C401	6-5-6	D27276	L118	6-3-385	4422-4-26
C402	6-5-7	33C2	L119	6-3-211	4422-4-26
C403	6-5-12	33C2	L121	6-3-399	BS217
C404	6-5-21	D36523	L122	6-6-74	MS75008-35
C405	6-5-14	D27950	L123	6-3-148	WEE-470
C406	6-5-40	36C175A	L124	6-3-173	MS90540-07
C407	6-5-39	36C175A	L30	6-6-86	546-7109-003
C408	6-5-38	36C175A	L31	6-6-85	MS18130-9
C409	6-5-36	36C175A	L32	6-6-83	547-2625-003
C410	6-5-47	D27276	L33	6-6-84	MS18130-8
C411	6-5-15	D27950	L401	6-5-19	C800
C412	6-5-44	36C175A	L402	6-5-10	C800
C413	6-5-41	36C175A	L403	6-5-20	240-0194-000
C69	6-3-316	19C372	L403	6-5-20	MS75103-10
C70	6-3-314	44C7A	L404	6-5-23	240-0194-000
C71	6-6-20	557006C0P039R	L404	6-5-23	MS75103-10
C72	6-3-348	36C175A	L405	6-5-13	240-0194-000
C73	6-3-342	40C73A1	L405	6-5-13	MS75103-10
C74	6-6-21	557006C0P039R	L67	6-6-82	MS18130-9
C8	6-3-235	41C92	L68	6-6-80	547-2625-003
C9	6-3-258	44C7A	L69	6-6-81	MS18130-8
DS1	6-3-52	GE44	L70	6-3-318	MS90539-15
FL1	6-3-25	X269-1	L71	6-6-79	MS18130-8
			L72	6-6-77	547-2625-003

REFERENCE DESIGNATION INDEX

REFERENCE DESIGNATION	FIG - ITEM	PART NUMBER	REFERENCE DESIGNATION	FIG - ITEM	PART NUMBER
L73	6-6-78	MS18130-8	R142	6-3-412	RCR20G123KS
M1	6-3-408	163003-0100	R143	6-3-218	RCR20G224KS
P1	6-2-3	426-1809-000	R144	6-3-176	RCR20G474KS
P10	6-1-15	78S9M1001	R145	6-3-227	RCR20G3R9JS
P10	6-2-11	78S9M1001	R146	6-3-209	RCR07G221KS
P25	6-1-17A	KH3491	R147	6-3-283	RCR07G221KS
P4	6-2-8	426-1811-000	R148	6-3-163A	RCR07G395KS
P5	6-2-7	426-1809-000	R149	6-3-234	RCR07G223KS
P7	6-1-6	544-3143-002	R149	6-3-238	RCR07G223KS
Q1	6-3-124	2N388	R15	6-3-337	RCR20G102KS
Q1	6-3-124	618-4921-027	R151	6-3-345	RCR20G473KS
Q401	6-5-45	2N637B	R152	6-3-355	RCR07G104KS
Q402	6-5-48	2N637B	R153	6-3-230	RCR07G104KS
Q403	6-5-46	2N637B	R154	6-3-233	RCR07G104KS
Q404	6-5-42	2N637B	R155	6-3-98	RCR07G563KS
R1	6-3-257	RCR20G271JS	R156	6-3-97	RCR07G183KS
R10	6-3-344	RCR07G101KS	R17	6-3-365	RCR20G330KS
R100	6-3-262	RCR20G334KS	R18	6-3-374	RCR07G102KS
R100	6-3-262	RCR20G224KS	R19	6-6-52	RCR20G102KS
R101	6-3-297	RCR20G224KS	R2	6-3-307	RCR20G221JS
R102	6-3-292	RCR20G102KS	R20	6-3-391	RCR20G330KS
R103	6-3-363	RCR07G104KS	R21	6-3-384	RCR20G102KS
R104	6-3-373	RCR07G102KS	R22	6-3-397	RCR20G102KS
R105	6-4-5	RCR20G102KS	R23	6-3-215	RCR07G473KS
R106	6-4-2	RCR20G102KS	R24	6-3-217	RCR07G224KS
R107	6-3-123	RCR07G271KS	R25	6-3-225	VY9692
R108	6-3-181	RCR20G470KS	R25	6-3-225	WR5451
R109	6-3-163	RCR07G125KS	R26	6-3-223	RCR42G223KS
R11	6-3-341	RCR32G102KS	R27	6-3-228	RCR20G102KS
R110	6-3-267	RCR20G332KS	R29	6-3-175	RCR07G470KS
R111	6-3-415	RCR07G472KS	R3	6-3-351	RCR07G104KS
R112	6-3-293	RCR20G470KS	R30	6-3-172	RCR20G121KS
R113	6-3-130	RCR20G473KS	R31	6-3-187	RCR20G102KS
R114	6-3-353	RCR20G221KS	R32	6-3-168	RCR07G334KS
R116	6-3-367	RCR20G473KS	R35	6-3-185	RCR07G104KS
R117	6-3-296	RCR20G470KS	R36	6-3-186	RCR07G473KS
R118	6-3-207	RCR32G680KS	R37	6-3-180	376-0201-000
R119	6-3-210	RCR42G330KS	R37	6-3-180	WR5453
R12	6-3-320	RCR20G330KS	R38	6-3-182	376-J203-000
R120	6-3-171	RCR32G680KS	R38	6-3-182	WR5455
R121	6-3-213	RCR20G471KS	R39	6-3-189	RCR20G473KS
R122	6-3-281	RCR20G100KS	R40	6-3-166	RCR07G101KS
R123	6-3-100	RCR07G393KS	R401	6-5-28	RCR20G151KS
R124	6-3-349	RCR07G106KS	R402	6-5-29	RCR32G472KS
R125	6-3-87	RCR07G224KS	R403	6-5-26	RCR20G151KS
R126	6-3-336	RCR07G473KS	R404	6-5-27	RCR32G472KS
R128	6-3-128	RCR07G222KS	R405	6-5-25	RCR32G472KS
R129	6-3-174	RCR32G121KS	R406	6-5-24	RCR20G151KS
R13	6-3-322	RCR07G224KS	R407	6-5-4	PW5-1000-10
R130	6-3-269	RCR32G121KS	R408	6-5-3	PW5-1000-10
R131	6-3-170	RCR20G100KS	R409	6-5-16	RCR20G102KS
R132	6-3-104	RCR07G470KS	R41	6-3-188	RCR32G153KS
R133	6-3-93	RCR20G101KS	R410	6-5-18	RCR20G102KS
R133	6-3-93	RCR07G101KS	R411	6-5-22	RCR32G102KS
R134	6-3-265	RCR20G390KS	R42	6-3-190	RCR20G102KS
R135	6-3-145	RCR07G151KS	R43	6-3-195	RCR07G395KS
R136	6-3-140	RCR07G151KS	R44	6-3-193	RCR20G102KS
R137	6-3-323	RCR07G470KS	R45	6-3-126	RCR20G102KS
R138	6-3-392	RCR20G123KS	R46	6-3-137	RCR07G152KS
R139	6-3-371	RCR07G101KS	R47	6-3-132	RCR07G560KS
R14	6-3-340	RCR20G102KS	R48	6-3-135	RCR07G152KS
R140	6-3-212	RCR42G330KS	R49	6-3-144	RCR07G104KS
R141	6-3-413	LW9778	R5	6-3-329	RCR07G103KS

REFERENCE DESIGNATION INDEX

REFERENCE DESIGNATION	FIG - ITEM	PART NUMBER	REFERENCE DESIGNATION	FIG - ITEM	PART NUMBER
R50	6-3-150	RCR07G104KS	TR1	6-6-107	599-2004-5
R51	6-3-118	RCR07G272KS	TR10	6-3-252	6H12
R52	6-3-129	RCR07G333KS	TR11	6-3-402	6H12
R53	6-3-119	RCR07G332KS	TR12	6-4-10	6H12
R54	6-3-121	RCR07G223KS	TR13	6-3-332	1909
R55	6-3-120	RCR20G682KS	TR14	6-3-339	1560
R56	6-3-122	RCR42G223KS	TR15	6-3-362	1520A
R57	6-3-432	TR8169	TR16	6-3-378	332-1403-165
R58	6-3-92	RCR20G332KS	TR17	6-4-14	1520A
R59	6-3-282	RCR20G682KS	TR2	6-5-50	1542A
R6	6-3-326	RCR07G103KS	TR2	6-3-198	6H12
R60	6-3-270	RCR20G474KS	TR3	6-5-30	6H12
R61	6-3-113	RCR20G102KS	TR3	6-3-160	6H12
R62	6-3-208	RCR20G102KS	TR4	6-5-31	6H12
R63	6-3-274	RCR20G474KS	TR4	6-3-161	6H12
R64	6-3-419	RN55D4221F	TR5	6-5-5	1532A
R65	6-3-103	RCR20G102KS	TR5	6-3-155	6H12
R66	6-3-94	RCR20G32KS	TR6	6-5-11	1542A
R67	6-3-134	RCR07G104KS	TR6	6-3-156	6H12
R68	6-3-115	RCR20G820KS	TR7	6-5-32	1542A
R69	6-3-81	RCR32G102KS	TR7	6-3-305	6H12
R7	6-3-221	RCR32G102KS	TR8	6-3-304	6H12
R70	6-3-114	RCR42G393KS	TR9	6-3-251	6H12
R71	6-3-82	RCR20G122KS	T1	6-3-44	X201-2
R72	6-3-285	RCR20G102KS	T10	6-6-72	X189-2
R73	6-3-85	RCR20G224KS	T11	6-3-370	X188-1
R74	6-3-312	RCR07G392KS	T12	6-3-13	X209-2
R75	6-3-432	TR8169	T13	6-3-11	X209-2
R76	6-3-271	RCR20G222KS	T14	6-3-39	X206-2
R77	6-3-288	RCR20G104KS	T15	6-3-41	X206-2
R78	6-3-291	RCR20G224KS	T16	6-3-27	X364-1
R79	6-3-216	RCR20G222KS	T2	6-3-43	X201-2
R8	6-3-315	RCR07G104KS	T3	6-3-38	X205-2
R80	6-3-420	RN55D1782F	T4	6-3-14	956-0614-410
R81	6-4-12	RCR42G102KS	T401	6-5-2	664-1020-000
R82	6-3-290	RCR20G512JS	T6	6-4-17	37558
R83	6-3-284	RCR20G751JS	T7	6-3-35	X207-2
R84	6-3-279	RCR20G152JS	T8	6-3-222	E13657
R86	6-3-429	376-7676-020	T9	6-6-72	X189-2
R87	6-3-409	RCR20G331KS	V1	6-3-21	60C6
R88	6-3-410	RCR20G473KS	V10	6-3-26	6EA8
R89	6-3-386	RCR20G474KS	V11	6-3-33	5670
R9	6-3-88	RCR07G473KS	V12	6-3-24	6BF5
R90	6-3-387	RCR20G472KS	V13	6-3-15	6AK6
R91	6-3-324	RCR07G474KS	V14	6-3-18	12AX7A
R92	6-6-70	RCR07G122KS	V16	6-3-29	6EA8
R93	6-6-71	RCR07G562KS	V17	6-3-30	7543
R94	6-3-327	RCR20G102KS	V2	6-3-16	6EA8
R95	6-3-107	RCR20G105KS	V3	6-3-10	6EA8
R96	6-3-101	RCR20G104KS	V4	6-3-9	6EA8
R97	6-3-98A	RCR20G562KS	V5	6-3-47	6BA6
R98	6-3-97A	RCR20G102KS	V6	6-3-46	12AX7A
R99	6-3-259	RCR20G105KS	V7	6-3-45	6BA6
S1	6-3-411	210878K1AC	V8	6-3-40	6BA6
S2A	6-3-243	210874F	V9	6-3-36	6BA6
S2B	6-3-246	210874F	XDS1	6-3-53	4159-043
S2C	6-3-430	210430F1	XF1	6-4-20	HKPHJRZZ
S3	6-3-422	211952-187K1	XF401	6-5-34	HKPHJRZZ
S4	6-6-33	547-2661-004	XV1	6-3-360	TS102P01
S5	6-6-34	547-2661-004	XV10	6-3-359	TS103P01
S7	6-3-413	LW9778	XV11	6-3-159	TS103P01
TB1	6-5-49	1542A	XV11	6-3-159	TS103P02
TR1	6-6-107	599C2004-5	XV12	6-3-301	TS102P01

section 6
parts list

REFERENCE DESIGNATION INDEX

REFERENCE DESIGNATION	FIG - ITEM	PART NUMBER	REFERENCE DESIGNATION	FIG - ITEM	PART NUMBER
XV13	6-3-303	TS102P01			
XV13	6-3-303	TS102P02			
XV13	6-3-303	TS102P01			
XV14	6-3-302	TS103P01			
XV14	6-3-302	TS103P02			
XV14	6-3-302	TS103P01			
XV16	6-3-299	TS103P01			
XV17	6-3-158	TS102P01			
XV2	6-3-361	TS103P01			
XV3	6-3-381	TS103P01			
XV4	6-3-401	TS103P01			
XV5	6-3-254	TS102P01			
XV5	6-3-254	TS102P02			
XV5	6-3-254	TS102P01			
XV6	6-3-199	TS103P01			
XV6	6-3-199	TS103P02			
XV8	6-3-196	TS102P01			
XV8	6-3-196	TS102P02			
XV8	6-3-196	TS102P01			
XY14	6-3-300	TS0205C01			
XY15	6-3-157	TS0205C01			
XY17	6-3-379	TS0205C01			
Y14	6-3-28	BL289-1424-000			
Y15	6-3-17	B9-7064-010			
Y16	6-3-350	289-1576-00M20			
Y17	6-3-12	S289-1587-000			

SCHEMATIC CHANGES

REVISION IDENTIFICATION	DESCRIPTION OF REVISION AND REASON FOR CHANGE	SERVICE BULLETIN	EFFECTIVITY
1	Reduced number of fixed capacitors at the input of filter circuits by removing C128, C129, C131, and C132 and relocating C130 and C127.		
2	Changed BFO circuit to reduce spurious 500-kHz signal by adding C337, relocating L114, relocating and changing value of C224, changing value of R156, adding capacitor 327, and replacing R99 with R155.		
3	Added additional selection of replacement transistor for Q1.		
4	Decreased value of R100 from 330 k Ω to 220 k Ω to ensure that calibration oscillator will oscillate.		
5	Changed LF crystal oscillator screen grid bypass capacitor C263 from 0.01 to 0.001 to prevent parasitic oscillations.		
6	Changed C224 from 470 to 390 to improve resonance.		
7	Added CR501, CR502, R502, R505, C510, C509, and L504 to reduce higher harmonic output of VFO and stabilize against voltage changes; changed C505 from 68 to 27 picofarads, and R503 from 56 to 33 k Ω ; and deleted C506.		

*51S-1/1F/1B Receiver, Schematic Diagram
 Figure 7-1 (Sheet A)*

SCHEMATIC CHANGES

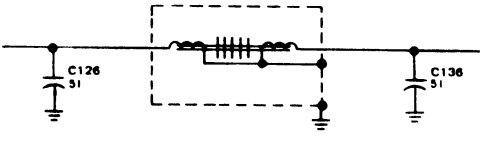
REVISION IDENTIFICATION	DESCRIPTION OF REVISION AND REASON FOR CHANGE	SERVICE BULLETIN	EFFECTIVITY
8	Optional 0.3-kHz CW filter may be used.		
9	<p>T14, T15, and C134 may be optionally replaced with 6-kHz mechanical filter; schematic representation is as follows:</p> 		
10	<p>FL2 and FL3 may be optionally replaced with 3.1-kHz mechanical filters.</p>		

51S-1/1F/1B Receiver, Schematic Diagram
 Figure 7-1 (Sheet B)

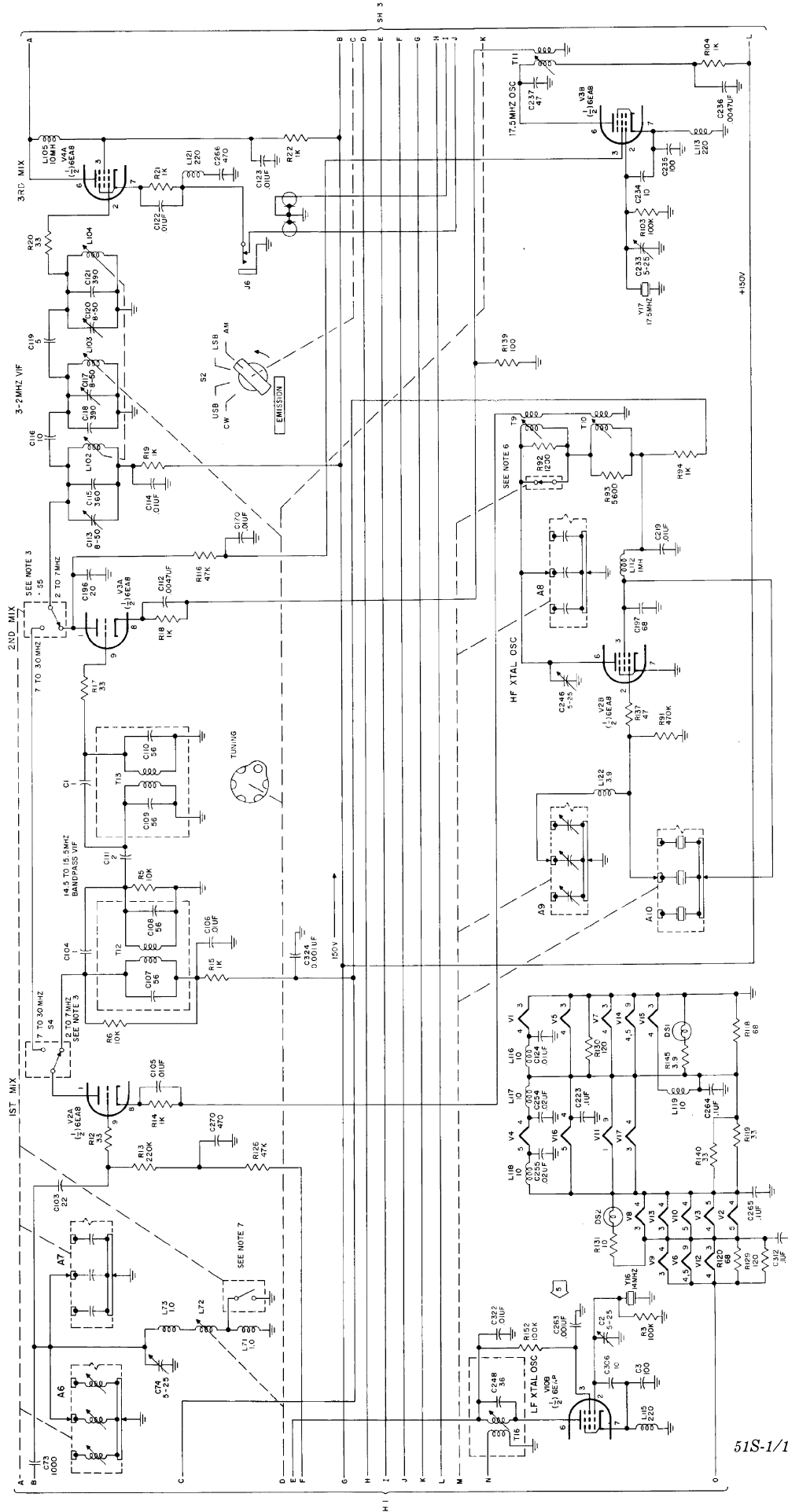

51S-1/1F/1B Receiver, Schematic Diagram
Figure 7-1 (Sheet 2)

TP3-8697-045

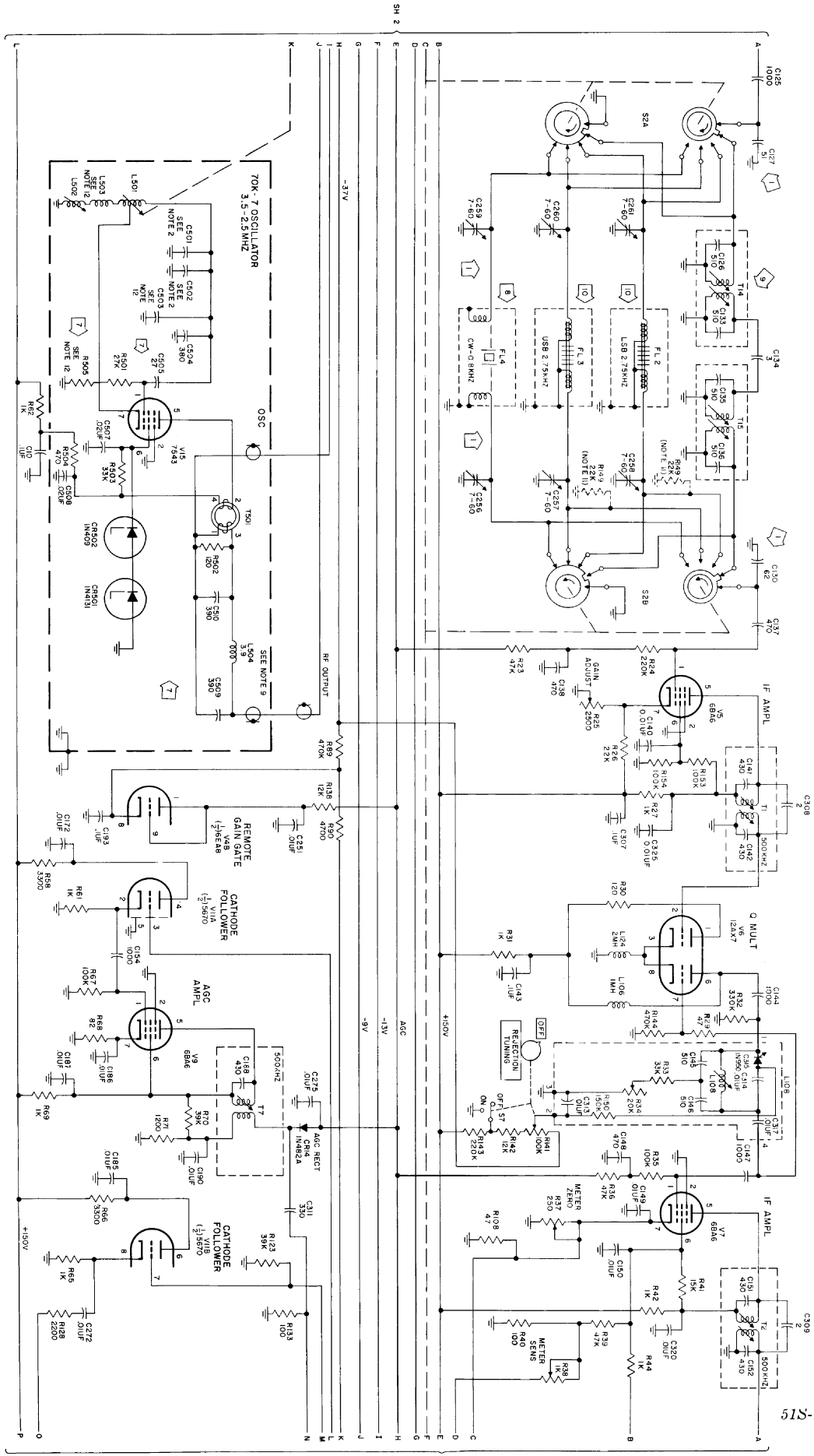

TP3 - 8697-045

51S-1/1F/1B Receiver, Schematic Diagram
Figure 7-1 (Sheet 3)

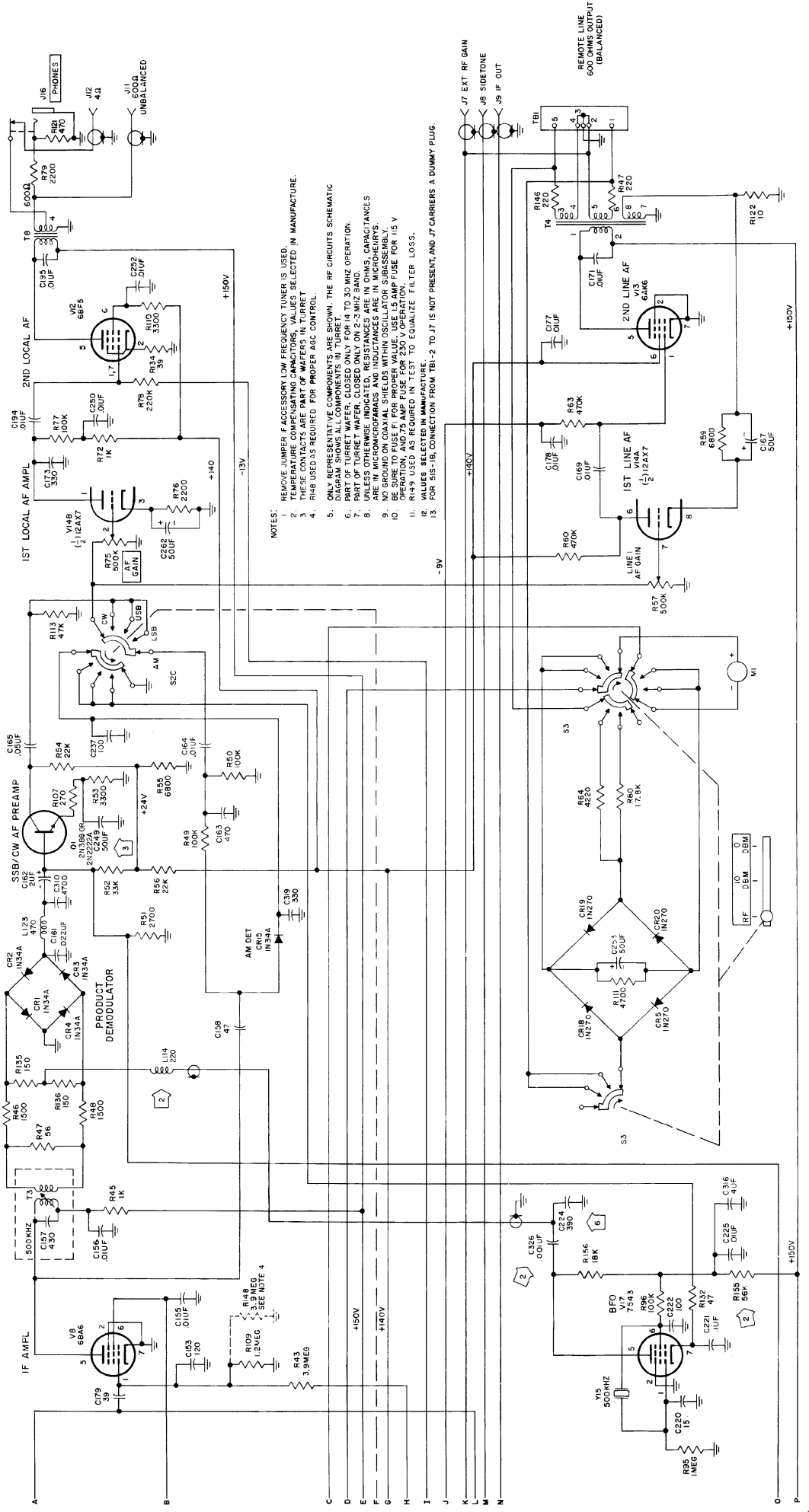

- NOTES:
- REMOVE JUMPER F ACCESSORY LOW FREQUENCY TUNER IS USED.
 - TEMPERATURE COMPENSATING CAPACITORS, VALUES SELECTED IN MANUFACTURE.
 - THESE CONTACTS ARE PART OF WAFERS IN TURRET.
 - R1B USED AS REQUIRED FOR PROPER AGC CONTROL.
 - ONLY REPRESENTATIVE COMPONENTS ARE SHOWN, THE RF CIRCUITS SCHEMATIC DIAGRAM SHOWS ALL COMPONENTS IN TURRET.
 - RESISTANCE VALUES ARE IN OHMS UNLESS OTHERWISE INDICATED.
 - PART OF TURRET WAFER, CLOSED ONLY ON 2-3 MIZ BAND.
 - UNLESS OTHERWISE INDICATED, RESISTANCES ARE IN OHMS, CAPACITANCES ARE IN MICROMICROFARADS AND INDUCTANCES ARE IN MICROHENRYS.
 - BE SURE TO CHECK TURRET POSITIONING AND USE OF SSB/CW FROM SUBASSEMBLY.
 - RESISTOR VALUE IN THIS CIRCUIT IS A TYPICAL VALUE. CHECK FOR PROPER VALUE FOR HIS V OPERATION, AND 75 AMP FUSE FOR 230 V OPERATION.
 - R1A9 USED AS REQUIRED IN TEST TO EQUALIZE FILTER LOSS.
 - VALUES SELECTED IN MANUFACTURE.
 - FOR 51S-1B, CONNECTION FROM TBI-2 TO J7 IS NOT PRESENT, AND J7 CARRIES A DUMMY PLUG.

51S-1/1F/1B Receiver, Schematic Diagram
Figure 7-1 (Sheet 4)

TP3-8697-045

SCHEMATIC CHANGES

REVISION IDENTIFICATION	DESCRIPTION OF REVISION AND REASON FOR CHANGE	SERVICE BULLETIN	EFFECTIVITY
1	Reduced number of fixed capacitors at the input of filter circuits by removing C128, C129, C131, and C132 and relocating C130 and C127.		
2	Changed bfo circuit to reduce spurious 500-kHz signal by adding C337, relocating L114, relocating and changing value of C224, changing value of R156, adding capacitor 327, and replacing R99 with R155.		
3	Added additional selection of replacement transistor for Q1.		
4	Decreased value of R100 from 330 to 220 k Ω to ensure that calibration oscillator will oscillate.		
5	Changed LF crystal oscillator screen grid bypass capacitor C263 from 0.01 to 0.001 to prevent parasitic oscillations.		
6	Changed C224 from 470 to 390 to improve resonance.		
7	Added CR501, CR502, R502, R505, C510, C509, and L504 to reduce higher harmonic output of VFO, and stabilize against voltage changes; changed C505 from 68 to 27 picofarads, and R503 from 56 to 33 k Ω ; and deleted C506.		
8	Optional 0.3-kHz CW filter may be used.		

51S-1A/1AF Receiver, Schematic Diagram
 Figure 7-2 (Sheet A)

SCHEMATIC CHANGES

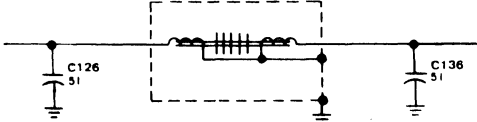
REVISION IDENTIFICATION	DESCRIPTION OF REVISION AND REASON FOR CHANGE	SERVICE BULLETIN	EFFECTIVITY
9	<p>T14, T15, and C134 may be optionally replaced with 6-kHz mechanical filter; schematic representation is as follows:</p> 		
10	<p>FL2 and FL3 may be optionally replaced with 3.1-kHz mechanical filters.</p>		

51S-1A/1AF Receiver, Schematic Diagram
 Figure 7-2 (Sheet B)

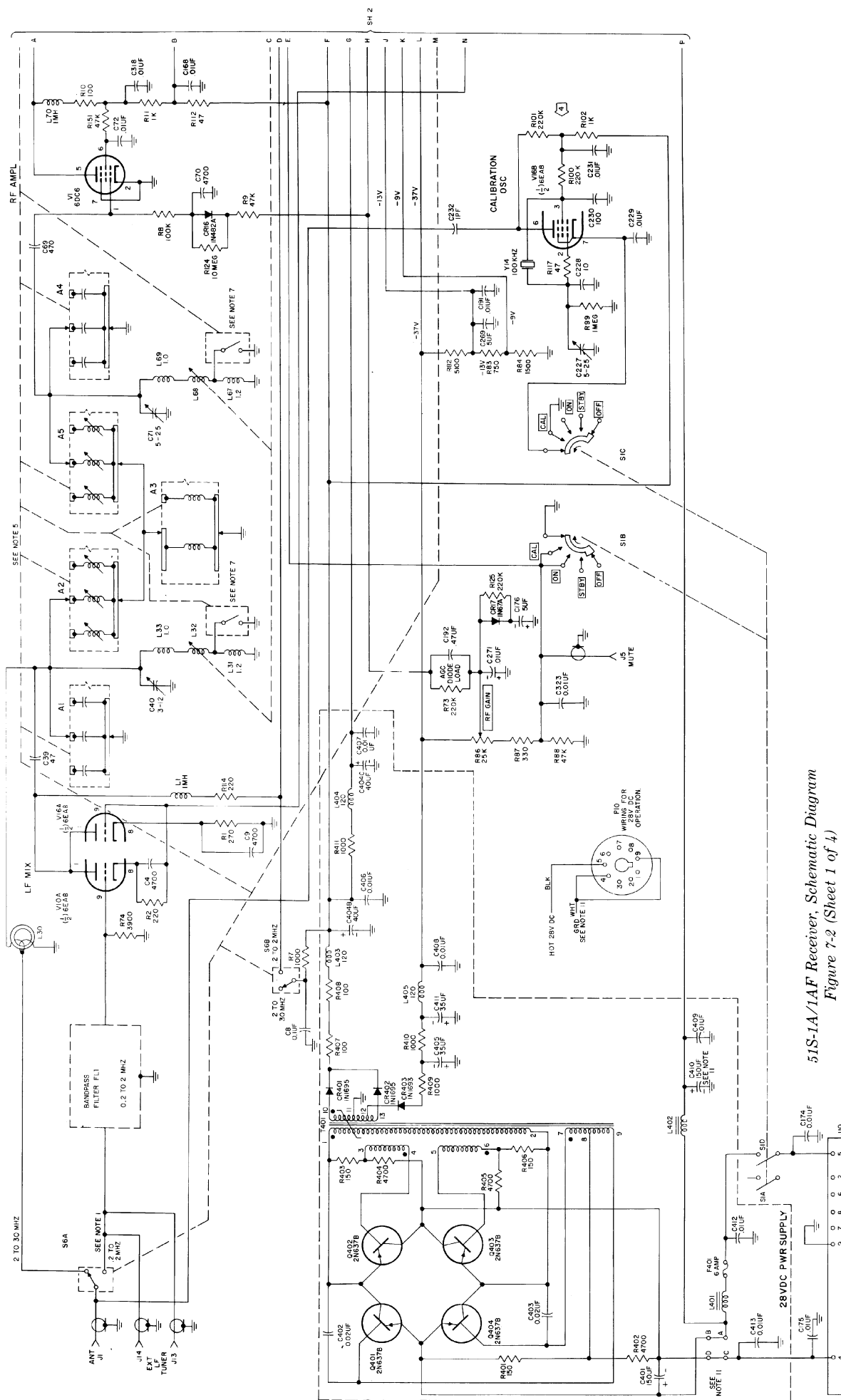

51S-1A/1AF Receiver, Schematic Diagram
Figure 7-2 (Sheet 1 of 4)

TP3-8698-045

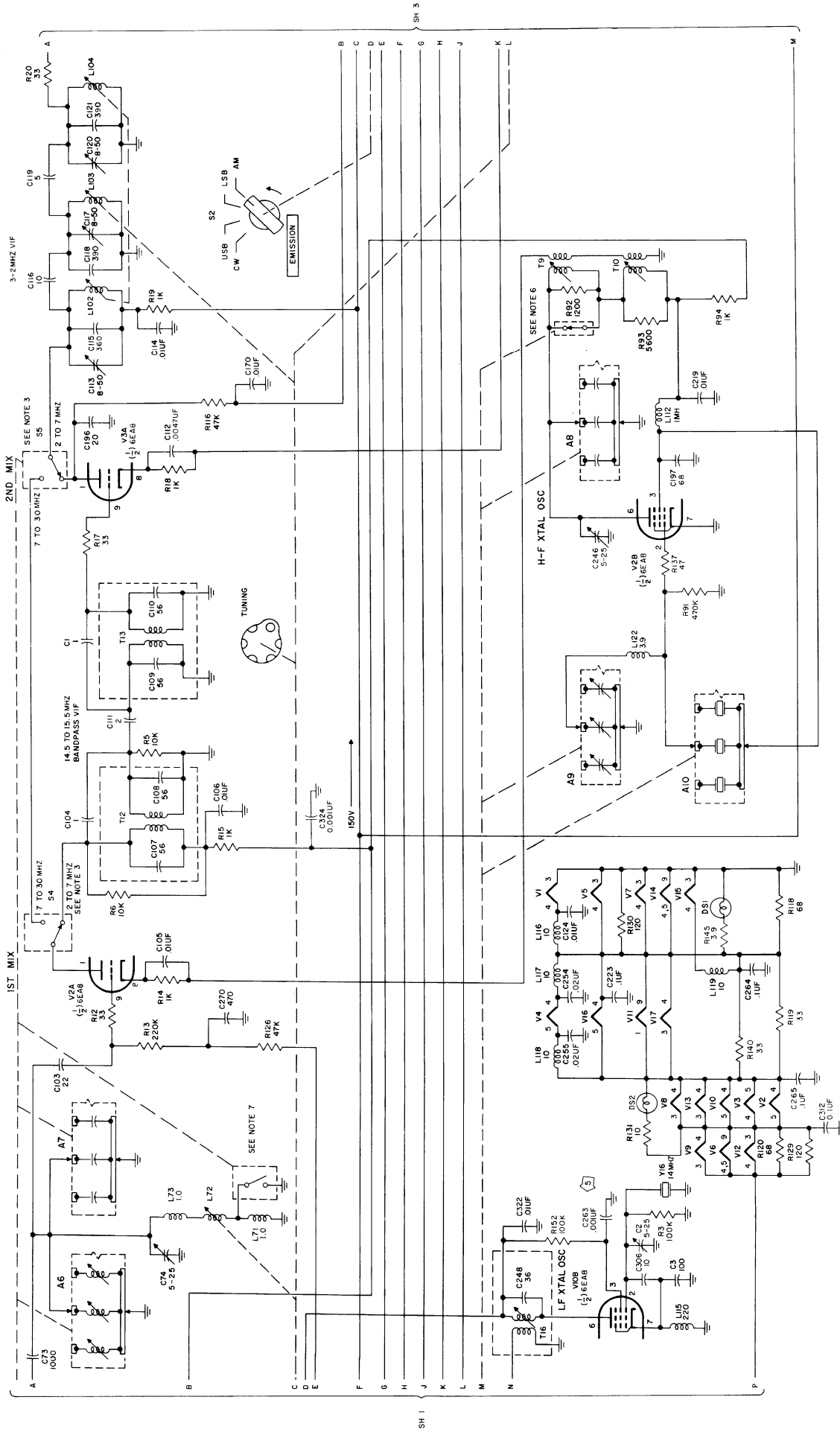

51S-1A/1AF Receiver, Schematic Diagram
Figure 7-2 (Sheet 2)

TP3-8698-045

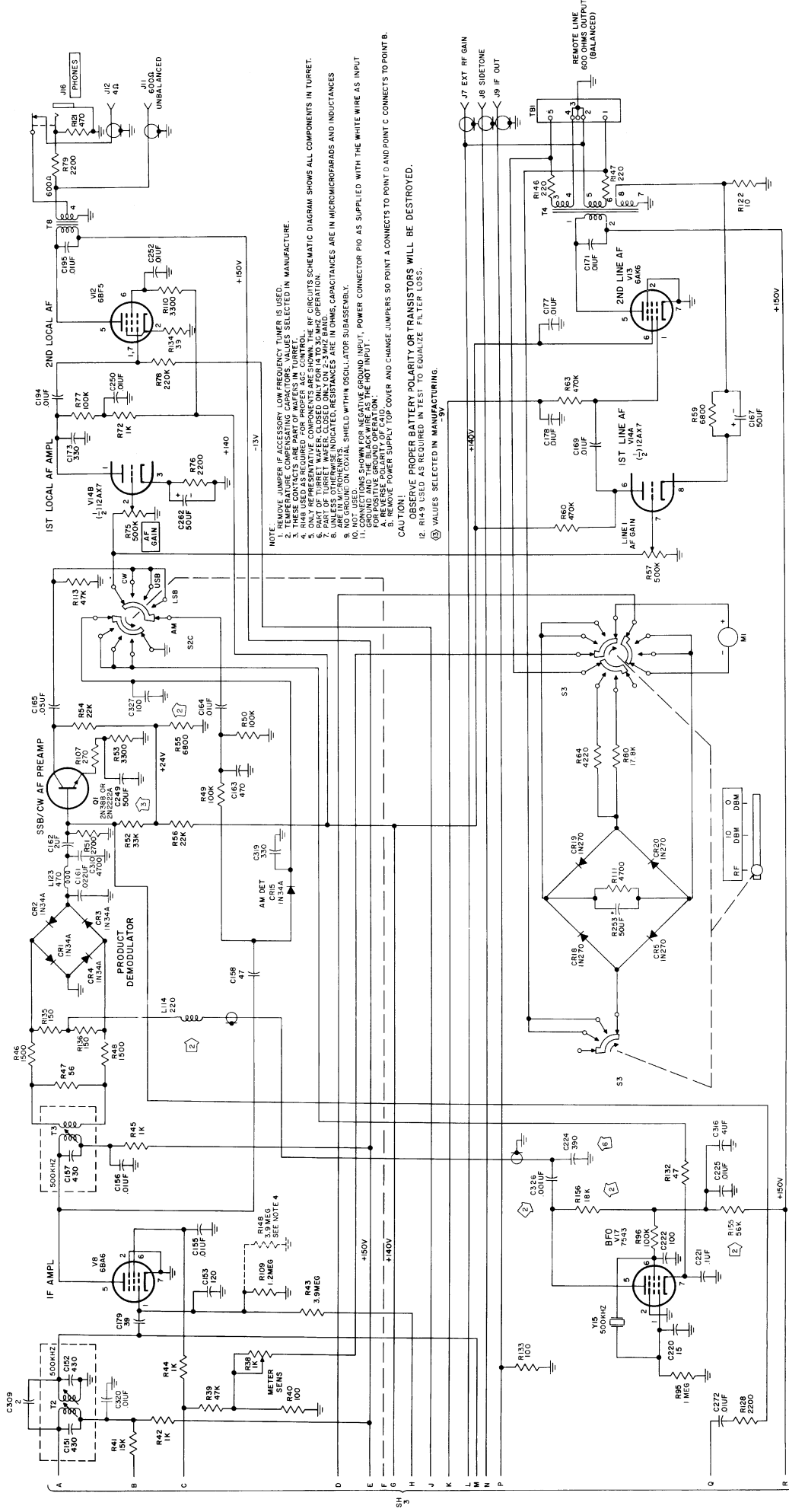

51S-1A/1AF Receiver, Schematic Diagram
Figure 7-2 (Sheet 4)

TP3-8698-045

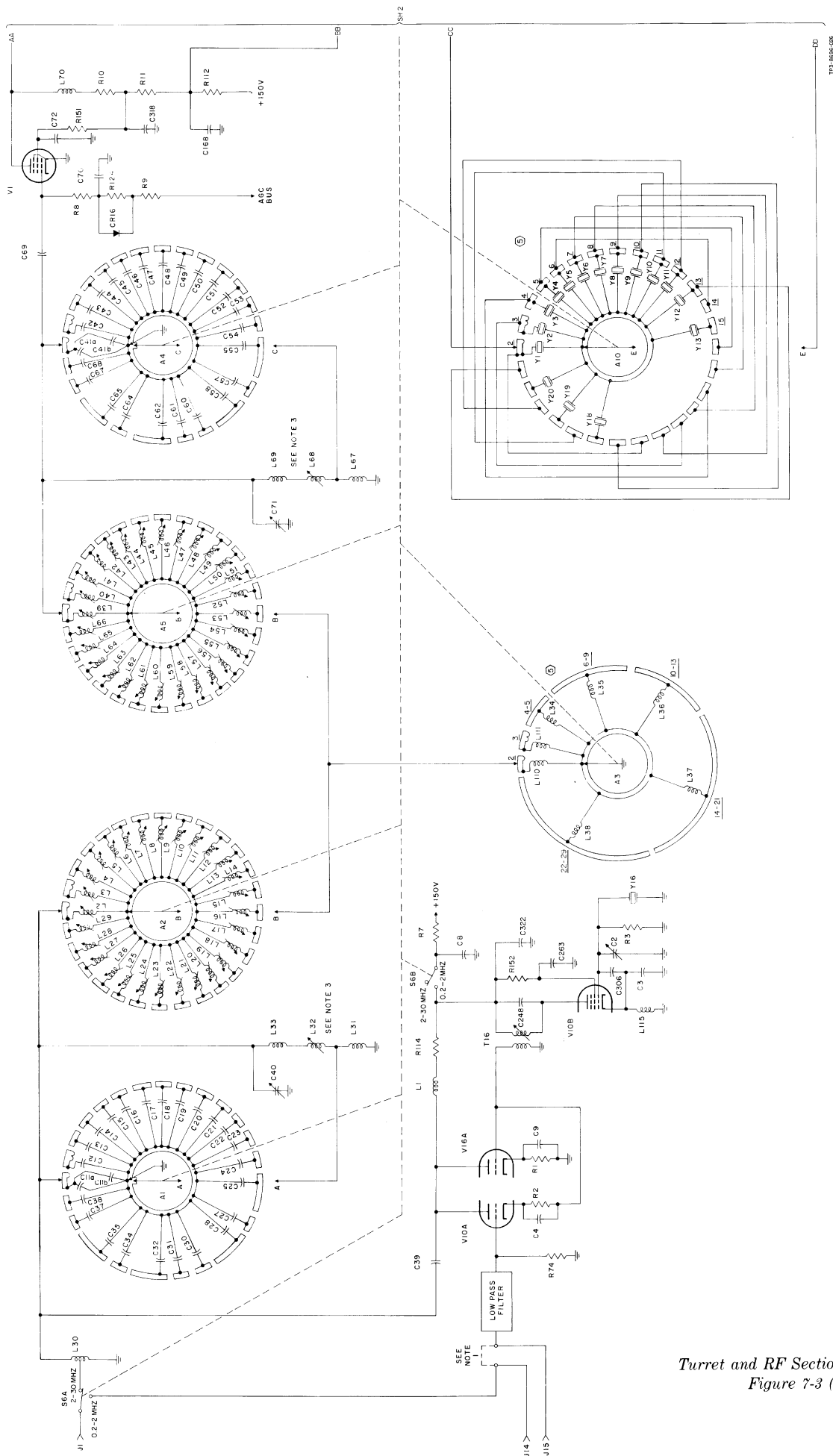

Turret and RF Section, Schematic Diagram
Figure 7-3 (Sheet 1 of 2)

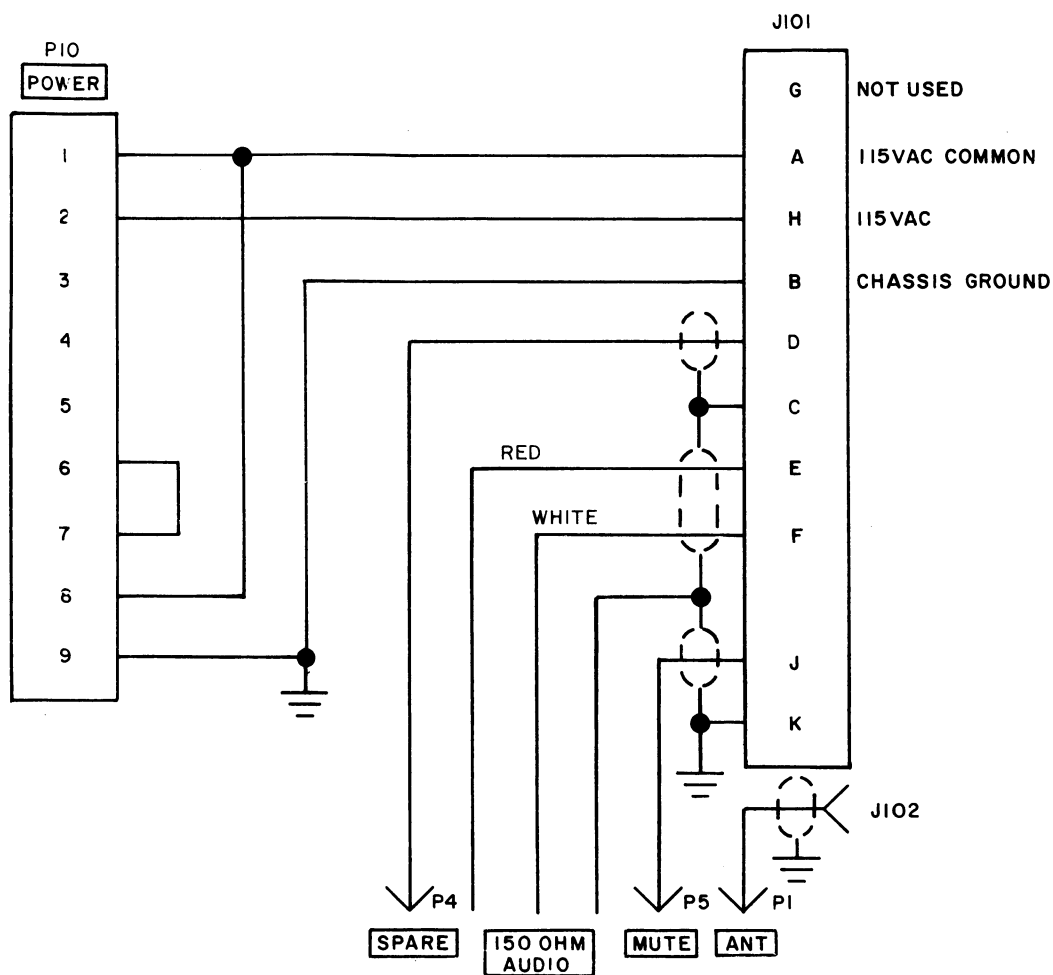

51S-1B Junction Box, Schematic Diagram
Figure 7-4

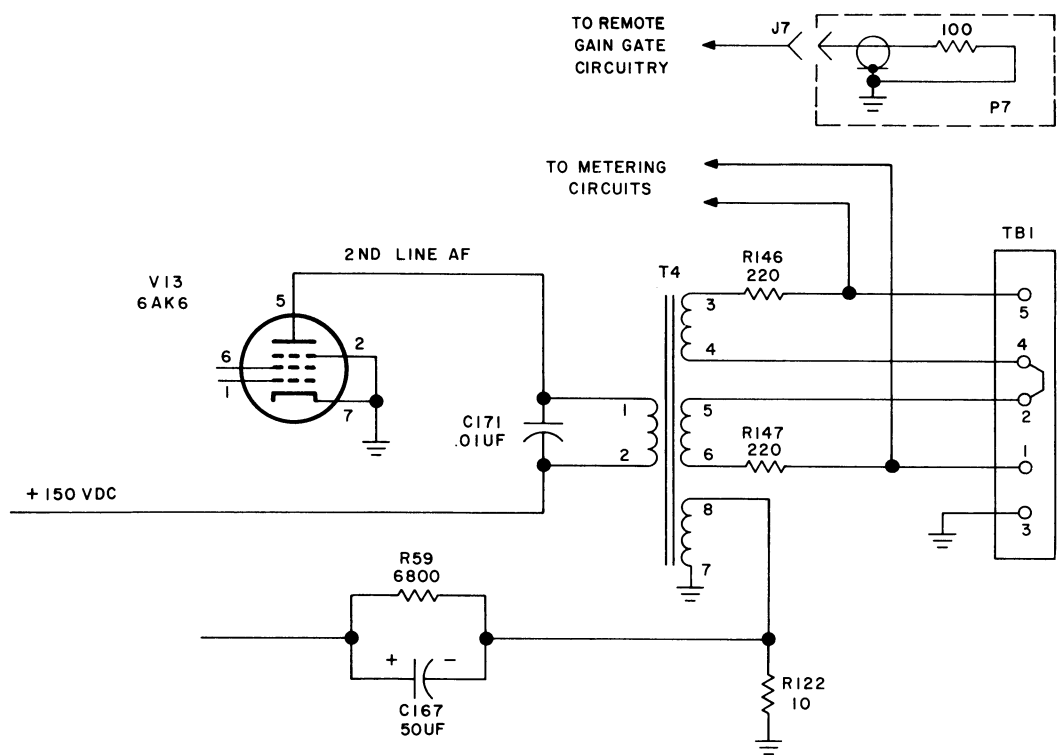

51S-1B Output Circuit, Partial Schematic Diagram
 Figure 7-5



Rockwell
International