

COLLINS KW-1

AMATEUR
TRANSMITTER



Here is **MAXIMUM POWER**

The Collins KW-1 Transmitter is engineered to equip the amateur for use of the absolute maximum power permitted by his license. This is the Transmitter known the world over for all the engineering planning that has gone into it, and it is the result of years of advanced planning and design — a unit you can be proud to own and operate. With the Collins KW-1 you can "reach" where you've never reached before. The KW-1 is a vfo controlled, bandswitching, gang tuned, phone and cw transmitter. Its input is a full 1000 watts on the 80, 40, 20, 15, 11, and 10 meter bands and 500 watts on the 160 meter band. The entire transmitter together with its power supply is enclosed in a handsome grey, wrinkle-finish cabinet.

RANGE

The KW-1's frequency range covers 160, 80, 40, 20, 15, 11, and 10 meter bands. Complete band-switching of the exciter, driver, and power amplifier is accomplished by a single control on the front panel. This reduces to four the number of tuning functions required in operation: bandswitch selection, frequency setting, PA tuning, and PA loading. Over any narrow frequency range, it is only necessary to adjust the frequency control, which is by means of a recently developed, extremely stable, hermetically sealed master oscillator.

TVI

The design of the KW-1 transmitter is such that spurious radiation has been reduced to a very low value, *particularly* on television frequencies. The r-f unit is completely shielded in a metal box inside the main cabinet. All circuits passing through this shield are well filtered for attenuation at television frequencies. These features minimize direct radiation from the cabinet and external leads. In the power amplifier the use of a pi section followed by an L section very effectively reduces harmonics of the carrier frequency. To this is added the attenuation of the 35C-2 low pass filter.

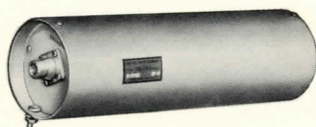

Spurious radiation from the antenna is attenuated by careful design of the r-f circuits. There are always 3 or more tuned circuits at the carrier frequency. The variable vacuum capacitor used for power amplifier plate tuning provides a low impedance circuit to ground at television frequencies.

The speech amplifier has a peak clipper and a low and high level filter, permitting high-percentage modulation without splatter.

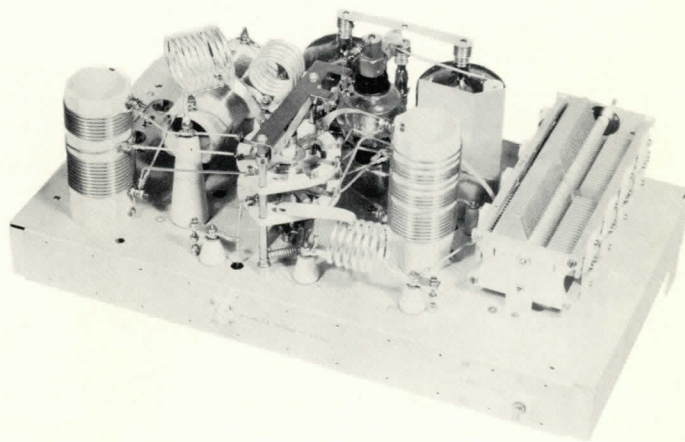

TUBE COMPLEMENT

Oscillator — two 6BA6's.
Exciter — one 6BA6, four 6AQ5's, one 807W, two VR105's, one 6A10 ballast tube. Power amplifier — two 4-250A's. Speech amplifier — one 12AX7, one 6AL5, two 12AU7's, two 6B4G's, two 810's. Rectifiers — two 872A's, one 5R4GY and three 5V4's.

METERS

Modulator current, PA plate current, high voltage, line voltage, multipurpose meter, antenna ammeter. Line fuses, plus overload relay in Class C amplifier current lead, provide circuit protection.

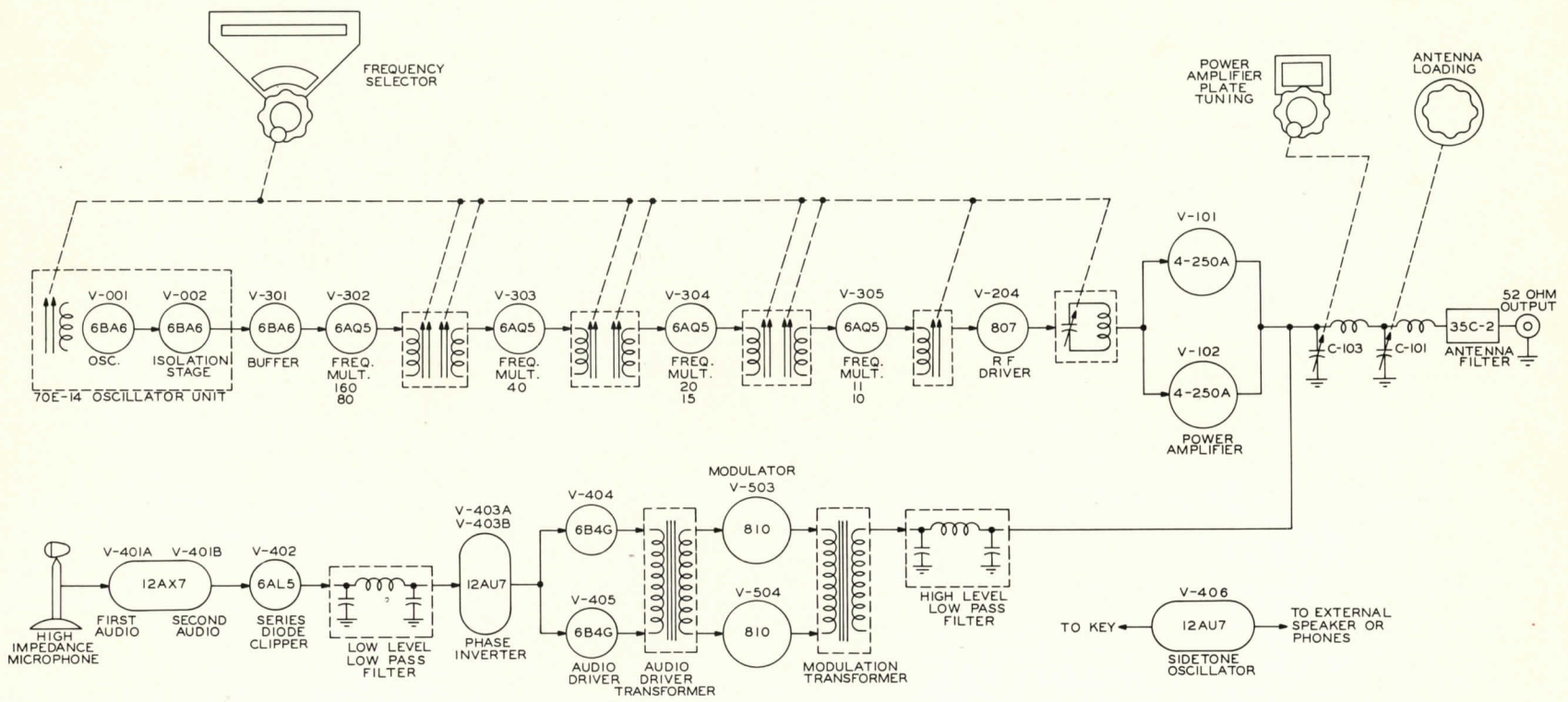

BLOCK DIAGRAM

KW-1 SPECIFICATIONS

- Power Amplifier Input 1000 watts
(500 watts on 160 meters)
- R-F Output Impedance 52 ohms
- Maximum Permissible Standing Wave Ratio 2.5 to 1
- Amateur Bands Covered 160, 80, 40, 20, 15, 11, 10 meters
- Frequency Range 1800-2000 kc
3500-4000 kc
7000-7300 kc
14,000-14,400 kc
21000-21450 kc
26,960-29,700 kc
- Emission Voice or cw
- Frequency Control 70E-14 Master Oscillator, 1675 to 2050 kc
- Microphone High impedance crystal or dynamic
- Phone Patch Impedance 600 ohms, unbalanced to ground
- Weight 600 pounds
- Dimensions 66½" high, 28" wide, 18" deep
- Circuit Protection Overload relay, fuses, high voltage arc gaps
- Tuning Controls Bandswitching, frequency selector, PA tuning, PA loading
- Other Controls Filament switch, filament voltage adjustment, plate switch, overload reset switch, overload relay adjustment, send-standby-calibrate switch, emission selector switch, tune-operate switch, meter switch, power amplifier excitation control, modulator bias control, audio driver bias control, clipping level, audio gain control, bandspread adjustment.
- Accessories Required High impedance microphone, telegraph key, 52 ohm antenna, wiring to power source.
- Power Source 230 v, 3 wire, 50/60 cycle, single phase, grounded neutral; or 115 v, 2 wire 50/60 cycle, single phase.
- Typical Power Demand, CW

Key closed	2000 w
Key open	800 w
Calibrate, key closed	660 w
Standby	500 w
- Typical Power Demand, Phone

100% sine wave mod.	3100 w
No modulation	2280 w
Calibrate	780 w
Standby	600 w

For excellence in amateur communications, it's . . .



COLLINS RADIO COMPANY, Cedar Rapids, Iowa

11 W. 42nd St., NEW YORK 36

1930 Hi-Line Drive, DALLAS 2

2700 W. Olive Ave., BURBANK