

**GENERAL**

- Tubes ..... Four plus rectifier.
  - Speaker ..... 5-inch PM.
  - Voice Coil Impedance ..... 3.2 ohms.
  - Headset Output ..... Low impedance.
  - Antenna ..... Provisions for external antenna with transmission line or single wire feed.
  - Tuning ..... Manual
- | Tuning Range | Band Selector Position | Frequency Range   |
|--------------|------------------------|-------------------|
|              | 1                      | 550 kc - 1850 kc. |
|              | 2                      | 1.7 mc - 5.1 mc.  |
|              | 3                      | 5 mc - 14.5 mc.   |
|              | 4                      | 13 mc - 31 mc.    |
- Intermediate Frequency..... 455 kc.
  - Power Supply..... 105-125 V. DC or 60 cycles AC.
  - Power Consumption ..... 30 Watts

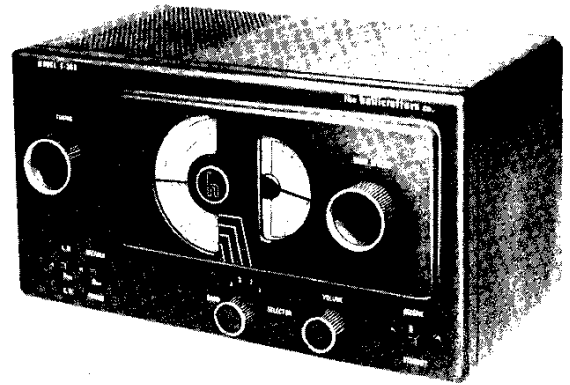

92X1153

**CAUTION** - The four rubber grommets insulate the chassis from the cabinet. Check the condition of these grommets and replace if necessary.

The standard RMA dummy antenna specified in the alignment chart consists of a 200 mmf condenser in series with a 20 uh r-f choke which is shunted by a 400 mmf condenser in series with a 400 ohm carbon resistor.

Set the following controls before alignment.

- AM/CW ..... Set at AM
- SPEAKER/PHONES ..... Set at SPEAKER
- VOLUME ..... Set at maximum
- RECEIVE/STANDBY..... RECEIVE
- BAND SPREAD ..... Set at zero

For the settings of the remaining controls, see alignment chart.

**ALIGNMENT PROCEDURE**

Holes in the bottom cover permit minor adjustment of the oscillator and mixer stage trimmers, however for complete alignment, the chassis will have to be removed from the cabinet. To separate the chassis from the cabinet, remove the back cover and bottom plate. The chassis is fastened to the cabinet by four front panel screws located near the slide switches and two cabinet screws located at the bottom rear of the cabinet.

**ALIGNMENT CHART**

Step	Dummy Antenna	Signal Generator Coupling	Signal Generator Frequency	Band Selector Setting	Receiver Dial Setting	Adjust	Remarks
1	.01 mfd cap.	Stator plates, front section of tuning gang.	455 kc	1	1000 kc	A,B,C,D	Adjust for max. audio output at speaker voice coil. Use just enough signal generator output to obtain a 50 mw signal level.
2**	See step 1	See step 1	455 kc (No modulation)	1	1000 kc	E	Set the AM/CW switch at CW. (Reset the switch at AM when step 2 is completed.) Correct BFO operation is obtained by varying the coupling between the wire "E" and the 12SK7 tube grid and plate terminals (Pins 4 and 8.) Pushing the wire toward the grid terminal increases the capacity and the strength of the beat.
3	Std. RMA dummy	High side to term. A1 on antenna strip. Jumper wire between A2 and G	30 mc	4	30 mc	*F,G	Max. output as in step 1.
4	Std. RMA dummy	See step 3.	14 mc	3	14 mc	*H,J	Max. output as in step 1.
5	Std. RMA dummy	See step 3	5 mc	2	5 mc	*K,L	Max. output as in step 1.
6	Std. RMA dummy	See step 3	1500 kc 600 kc	1	1500 kc 600 kc	*M,N *P	Max. output as in step 1.

\* Note - Calibration adjustments.

\*\* Note - This step is generally unnecessary. Adjustment should be made if a weak beat note is obtained on strong c-w signals indicating lack of coupling between wire "E" and tube socket wiring.

MODELS S-38A,  
S-38B

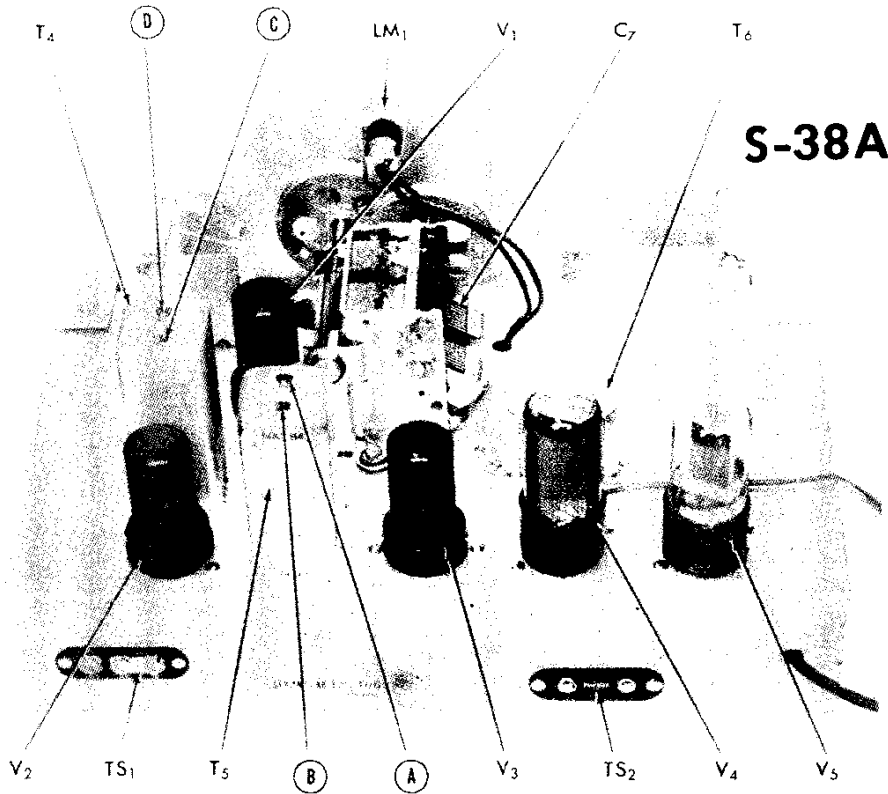

**S-38A**

92X812

Fig. 2. Top view, alignment adjustments and component location

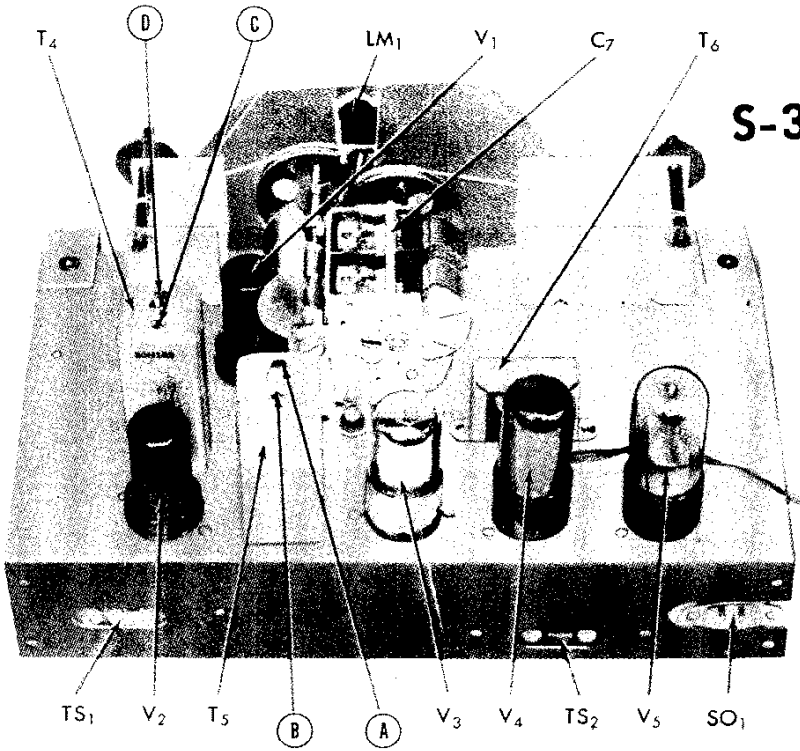

**S-38B**

92X1154

Fig. 2. Top view, alignment adjustments and component location

MODELS S-38A,  
S-38B

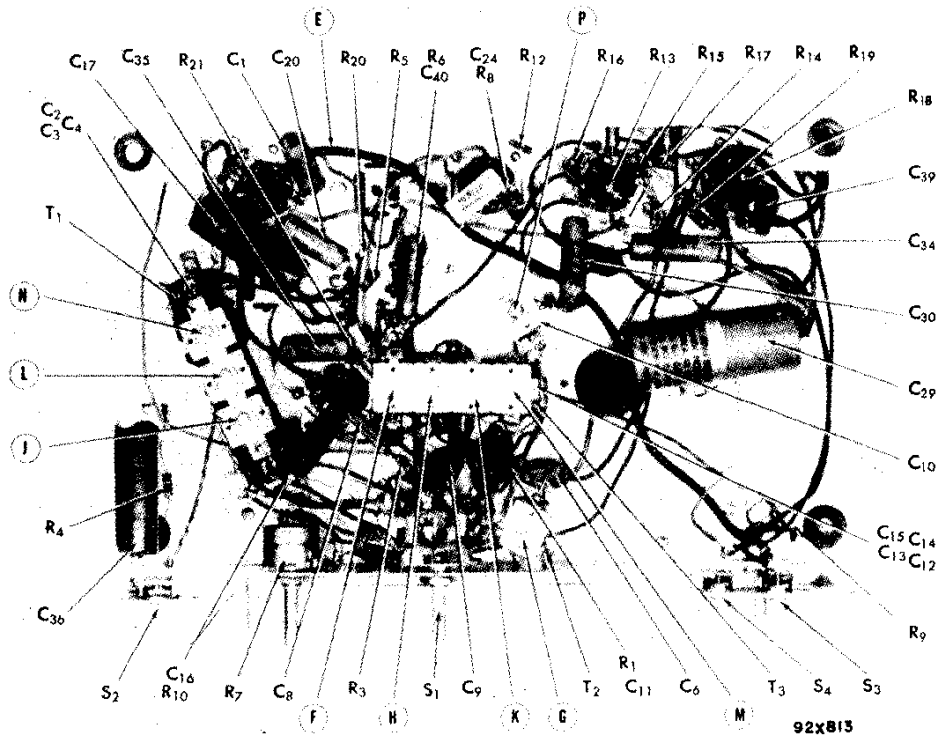

Fig. 3. Bottom view, alignment adjustments and component location

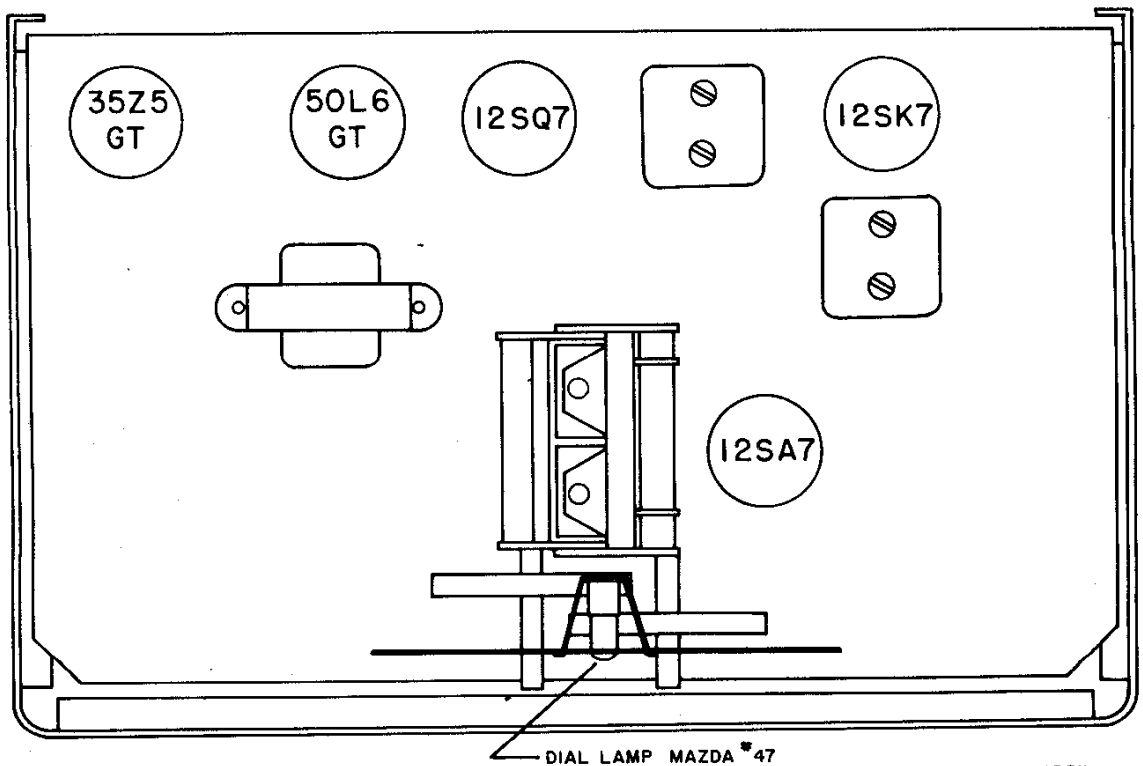
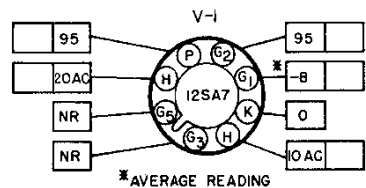
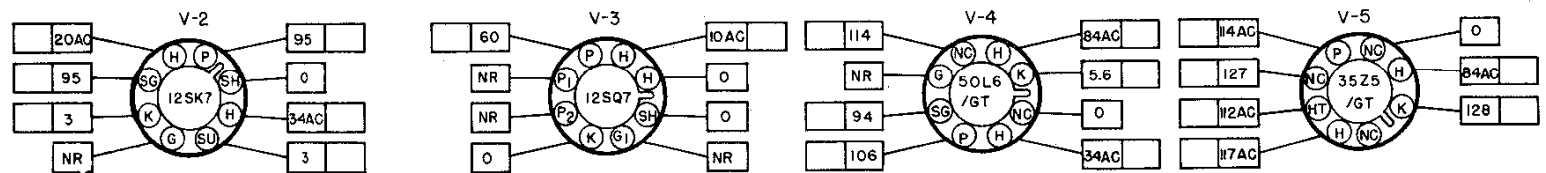

Fig. 4. Top view, location of tubes and dial lamps.

92B811



1. SOCKET VIEWS ARE BOTTOM VIEWS.
2. ALL VOLTAGES ARE MEASURED BETWEEN TUBE SOCKET TERMINALS & CHASSIS, WITH ZERO SIGNAL INPUT.
3. LINE VOLTAGE—117 V. AC. AC VOLTAGES WILL BE DC VOLTAGES WHEN OPERATING FROM A DC SOURCE.
4. ALL VOLTAGES SHOWN ARE DC UNLESS OTHERWISE SPECIFIED.
5. DC VOLTAGES SHOWN WERE MEASURED WITH AN ELECTRONIC VOLTMETER.
6. "NC" NO CONNECTION. (VOLTAGES SHOWN FOR THIS TERMINAL ONLY WHEN TERMINALS ARE USED AS A TIE LUG.)
7. "NR" NOT READABLE (READING GENERALLY MEANINGLESS)
8.  SPACE PROVIDED FOR SERVICE METER READINGS.

Fig. 5. Tube socket voltage chart.

92G786

FRONT APRON

BOTTOM VIEW OF CHASSIS

**RESTRINGING DIAL CORD**

To restringing the general coverage tuning dial cord cut a 14-inch length of 30 lb. test dial cord and tie one end to the tension spring at position "1" on the diagram. Follow the sequence "1" through "15", and at position "15" stretch the tension spring and tie the cord securely.

To restringing the band spread tuning dial cord, cut a 16-inch length of dial cord and follow the procedure as above, starting at position "A" on the diagram. Note that the tuning drive shafts are wrapped with two and a fraction turns of dial cord for proper traction.

**REPLACING LAMPS**

Refer to Fig. 4, for the location of the dial lamp used in receiver. To gain access to the defective lamp, reach in through the rear of the cabinet (cover removed) and unclip the dial lamp socket by compressing the side springs. The socket may then be brought out into the open to change the defective lamp. Replace defective lamps with 6-8 V. Mazda #47 (Brown bead) lamps or equivalent.

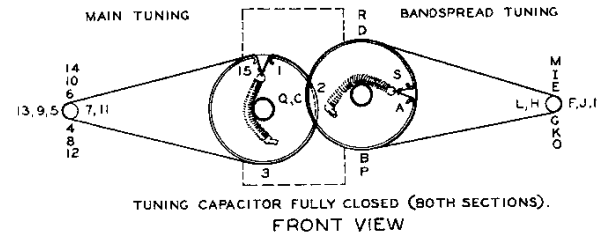

92X814

Fig. 1. Dial cable stringing procedure.

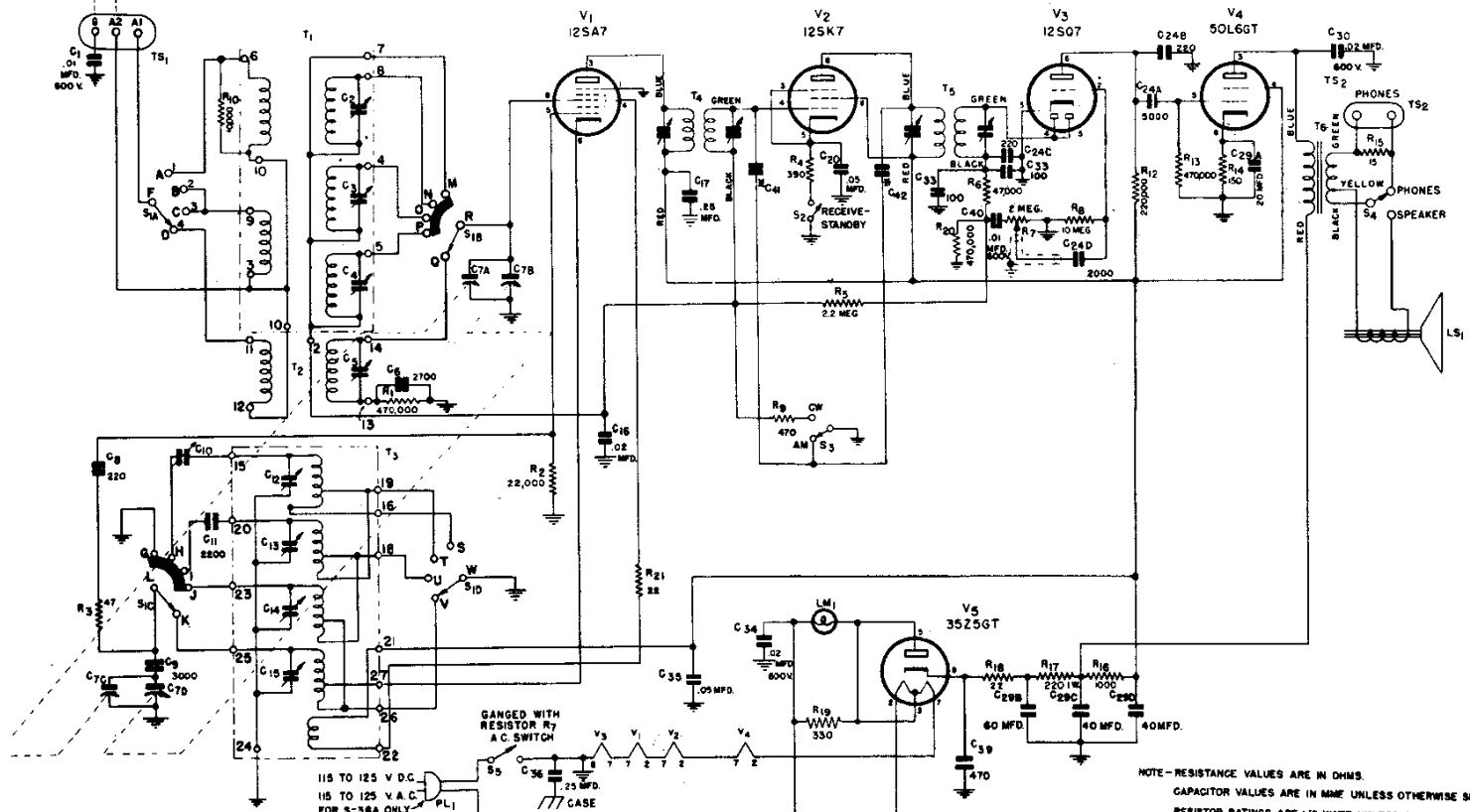

115 TO 125 V D.C.  
115 TO 125 V A.C.  
FOR S-38A ONLY

GANGED WITH RESISTOR R7  
A.C. SWITCH

USE DOTTED LINE  
CONNECTION FOR  
S-38B ONLY

NOTE—RESISTANCE VALUES ARE IN OHMS.  
CAPACITOR VALUES ARE IN MME UNLESS OTHERWISE SPECIFIED.  
RESISTOR RATINGS ARE 1/2 WATT UNLESS OTHERWISE SPECIFIED.  
NOTE—CAPACITY C-41 & C-42 DUE TO PLACEMENT OF WIRE.  
NOTE— CHASSIS GROUND  
 CABINET GROUND

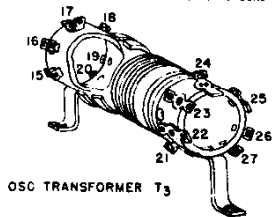
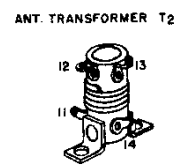
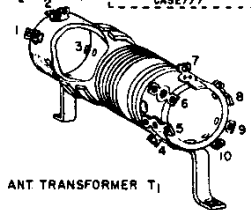
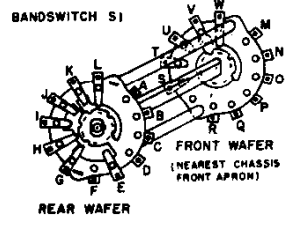

NOTE: DIMENSIONS & PROPORTIONS SHOWN IN PICTORIAL VIEWS HAVE BEEN EXAGGERATED FOR CLARITY OF TERMINAL LUG LOCATION.

Fig. 6. Schematic diagram.

990326-C

**PAGE 21-6 HALLICRAFTERS**

MODELS S-38A,  
S-38B

**SERVICE PARTS LIST**

Ref. No.	Description	Manufacturer's Part Number	Ref. No.	Description	Manufacturer's Part Number
<b>CONDENSERS</b>					
C-1,40	.01 mfd. 600 V., tubular	46A Y103J	S-1	Bandswitch assembly Switch, slide; RECEIVE- STANDBY Switch, slide; SPST; AM-CW & SPEAKER-PHONES Switch, power (Part of VOLUME control R-7)	60C393
C-2,3,4	Trimmers, adjustable (Part of transformer T-1)		S-2		60A244
C-5	Trimmer, adjustable (For transformer T-2)	44A039	S-3,4		60A243
C-6	2700 mmf 500 V, mica	47X30A272J	S-5		
C-7	Tuning condenser, 2 sections	48C162-1			
C-8	220 mmf 500 V, mica	47X20A221K			
C-9	3000 mmf 500 V, mica	47X30A302J			
C-10	Padder, adjustable (Band 1)	44A349			
C-11	2200 mmf 500 V, mica	47X30A222J			
C-12,13,14,15	Trimmers, adjustable (Part of transformer T-3)		PL-1		Line cord (Includes PL-2)
C-16	.02 mfd 400 V, tubular	46AW203J	TS-1	Terminal strip, antenna	88A671
C-17	.25 mfd 200 V, tubular	46A T254J	TS-2	Headset, jack	88A071
C-20,35	.05 mfd. 200 V, tubular	46A U503J	SO-1	Socket, a-c	10A286
C-24	Capacitor, composite; 5,000, 2X220, and 2000 mmf; 500 V.; ceramic	46A151		Socket, octal (tube)	6A250
C-29	60-40-40 mfd 150 V, 20 mfd. 25 V, electrolytic	45B091		Socket, dial light	86A011
<b>CONNECTORS</b>					
C-30,34	.02 mfd 600 V, tubular	46A Y203J		<b>TUBES, RECTIFIERS AND LAMPS</b>	
C-33	100 mmf. 500 V, mica	47X20B101K	V-1	Type 12SA7, mixer/oscillator	90X12SA7
C-36	.1 mfd. 400 V., tubular	46AV104J	V-2	Type 12SK7, i-f amplifier & BFO	90X12SK7
C-39	470 mmf 500 V, mica	CM20A471M	V-3	Type 12SQ7, detector & 1st audio amplifier	90X12SQ7
C-41,42	Wiring capacity		V-4	Type 50L6GT, audio power amplifier	90X50L6GT
<b>RESISTORS</b>					
R-1,13,20	470,000 ohms 1/2 watt, carbon	23X20X474M	V-6	Type 35Z5GT, rectifier	90X35Z5GT
R-2	22,000 ohms 1/2 watt, carbon	23X20X223M	LM-1	Lamp, dial light, Mazda #47	39A004
R-3	47 ohms 1/2 watt, carbon	23X20X470M		<b>CABINET PARTS</b>	
R-4	390 ohms 1/2 watt, carbon	23X20X391K		Clip, coil mtg (For transformer T-2)	76A362
R-5	2.2 megohms 1/2 watt, carbon	23X20X225M		Shaft, main tuning	74A318
R-6	47,000 ohms 1/2 watt, carbon	23X20X473M		Shaft, bandspread	74A319
R-7	Resistor, variable; VOLUME control	25B896		Washer, spring (for main tuning and bandspread drive shafts)	4A043
R-8	10 megohms 1/2 watt, carbon	23X20X106M		Spring, retainer ("C" washer type)	75A062
R-9	470 ohms 1/2 watt, carbon	23X20X471K		Dial cord	38A019
R-10	10,000 ohms 1/2 watt, carbon	23X20X103M		Spring, dial cord	75A012
R-12	220,000 ohms 1/2 watt, carbon	23X20X224M		Pointer, main tuning	82A177
R-14	150 ohms 1/2 watt, carbon	23X20X151K		Pointer, bandspread tuning	82A103
R-15	15 ohms 1/2 watt, carbon	23X20X150M		Dial scale	83C373
R-16	1000 ohms 1/2 watt, carbon	23X20X102M		Knob, VOLUME control and BAND SELECTOR	15A049
R-17	220 ohms 1 watt, carbon	23X30X221M		Knob, TUNING and BAND-SPREAD	15A047
R-18,21	22 ohms 1/2 watt, carbon	23X20X220M		Speaker, PM	85C030
R-19	330 ohms 1/2 watt, carbon	23X20X221M		Baffle, speaker	78B198
<b>TRANSFORMERS AND COILS</b>					
T-1	Transformer, antenna stage, Bands 1, 2 and 3	51C821		Cabinet back	8C1139
T-2	Transformer, antenna stage, Band 4	51B1015	LS-1	Cabinet bottom	8C1140
T-3	Transformer, oscillator stage, Bands 1, 2, 3 and 4	51C822		Mounting foot, rubber	16A007
T-4	Transformer, i-f amp. stage	50B183		Window, dial	22B311
T-5	Transformer, i-f amp. stage (diode)	50B184			
T-6	Transformer, audio output	55A127			