

New

# the hallicrafters co.

## SERVICE BULLETIN FOR MODEL S-40A

### GENERAL

- Tubes . . . . . Eight plus rectifier
- Speaker . . . . . 5-inch PM
- Speaker V.C. Impedance. . . 3.2 ohms
- Headset Output . . . . . Low Impedance
- Antenna . . . . . Provision for external antenna
- Tuning. . . . . Manual
- Tuning Range. . . . . Band Selector Position      Frequency Range

Band Selector Position	Frequency Range
1.	540 kc - 1680 kc
2.	1680 kc - 5.4 mc
3.	5.3 mc - 15.5 mc
4.	15.5 mc - 44 mc

- Intermediate Frequency . . . 455 kc.
- Power Supply . . . . . Standard Model 105-125 V. 60 cycles AC  
Universal Model 105-250 V. 25/60 cycles AC
- Power Consumption . . . . . 75 Watts

### RESTRINGING DIAL CORD

To restring the general coverage tuning dial cord, cut an 18-inch length of 30 lb. test dial cord and tie one end to the tension spring of the main tuning capacitor drive pulley at position "1" on the diagram. Follow the numbers "1" through "4", and at position "4" stretch the tension spring and tie the cord securely.

To restring the band spread tuning dial cord, cut a 36-inch length of dial cord and follow the procedure as above, starting at position "A" on the diagram. Note that the tuning drive shafts are wrapped with three turns of dial cord for proper traction.

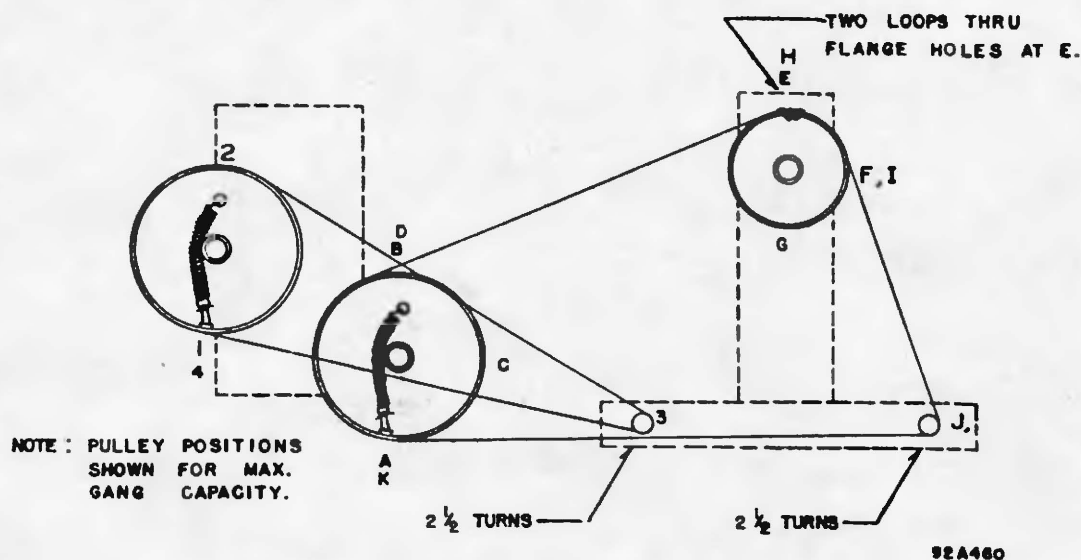
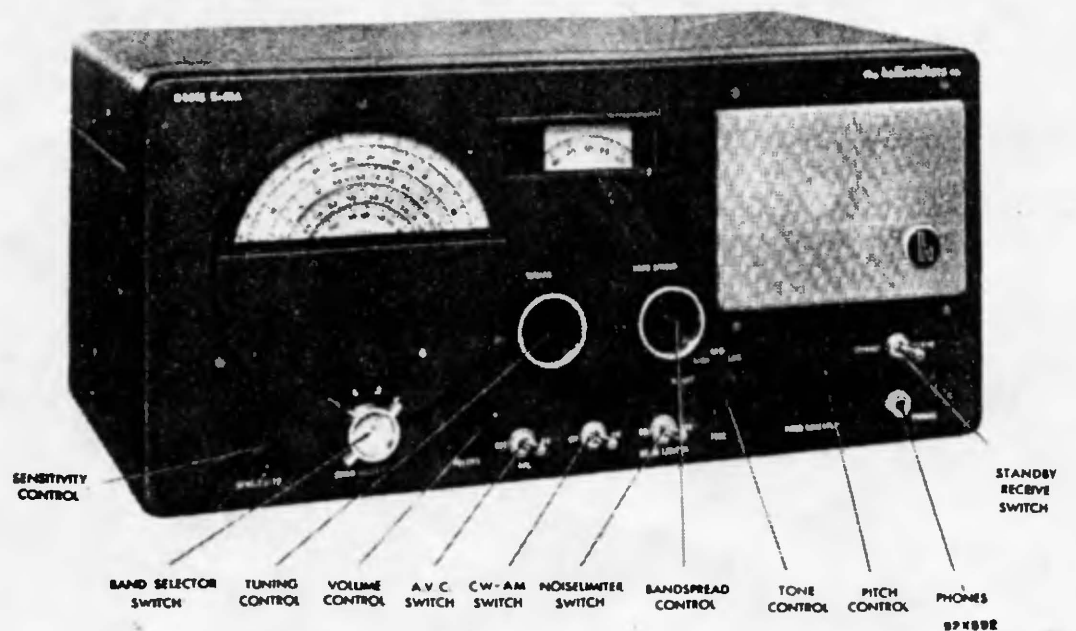

Fig. 1. Dial cable stringing procedure



### REPLACING LAMPS

Refer to Fig. 4 for the location of the two dial lamps used in the receiver. To gain access to the defective lamps, lift the cabinet cover and unclip the dial lamp sockets. The sockets may then be brought out into the open to change the defective lamp. Replace defective lamps with 6-8 V. Mazda #44 (Blue bead) lamps or equivalent.

### ALIGNMENT PROCEDURE

Set the following controls before alignment.

- SENSITIVITY . . . . . Set at maximum
- VOLUME . . . . . Set at maximum
- AVC switch. . . . . Set at OFF
- Band Spread . . . . . Set at zero
- CW/AM . . . . . Set at AM (See step 2)
- NOISE LIMITER . . . . . Set at OFF
- STANDBY RECEIVE. . . . . Set at RECEIVE
- TONE SWITCH . . . . . Set at HIGH

For the settings of the remaining controls, see alignment chart.

Access to the i-f amplifier alignment adjustments may be had through the cabinet top cover. R-F alignment should be done through the holes provided in the cabinet bottom because the oscillator calibration will be effected slightly by changes in the capacity between the cabinet bottom and the r-f coils and wiring.

Before starting the alignment procedure, check the position of the general coverage dial index marker on the low frequency end of the range and the bandspread dial zero position. The general coverage condenser should index at max. capacity, and the bandspread condenser at min. capacity.

The standard RMA dummy antenna mentioned in the alignment chart consists of a 200 mmf. condenser in series with a 20 uh r-f choke which is shunted by a 400 mmf condenser in series with a 400 ohm carbon resistor.

## ALIGNMENT CHART

	Antenna	Signal Generator Coupling	Signal Generator Frequency	Band Switch Setting	Receiver Dial Setting	Adjust	Remarks
	None	Stator plates in center section of tuning gang.	455 kc	"1"	1000 kc	1,2,3	Maximum audio output at speaker voice coil. Use just enough signal generator output to obtain a 50 mw signal level.
2	None	See step 1	455 kc (No modulation)	"1"	1000 kc	T-17	With the CW/AM switch set at CW, remove the pitch control knob and adjust T-17 for zero beat. Replace the knob with the dot in the center position.
3	Std RMA dummy	"A1" on antenna strip. Jumper connected between "A2" and "G"	36 mc	"4"	36 mc	*C-19,C-1, C-12	Maximum output as in step 1.
			18 mc		18 mc	*8,5,6	
4	Std RMA dummy	See step 3	14 mc	"3"	14 mc	*C-20,C-2, C-13	Maximum output as in step 1.
			10 mc		10 mc	*9,4,7	
5	Std RMA dummy	See step 3	5 mc	"2"	5 mc	*C-21,C-3, C-14	Maximum output as in step 1.
			1.8 mc		1.8 mc	*11	
6	Std RMA dummy	See step 3	1500 kc	"1"	1500 kc	*C-22,C-4, C-15	Maximum output as in step 1.
			600 kc		600 kc	*C-25	

\*Note - Calibration adjustments.

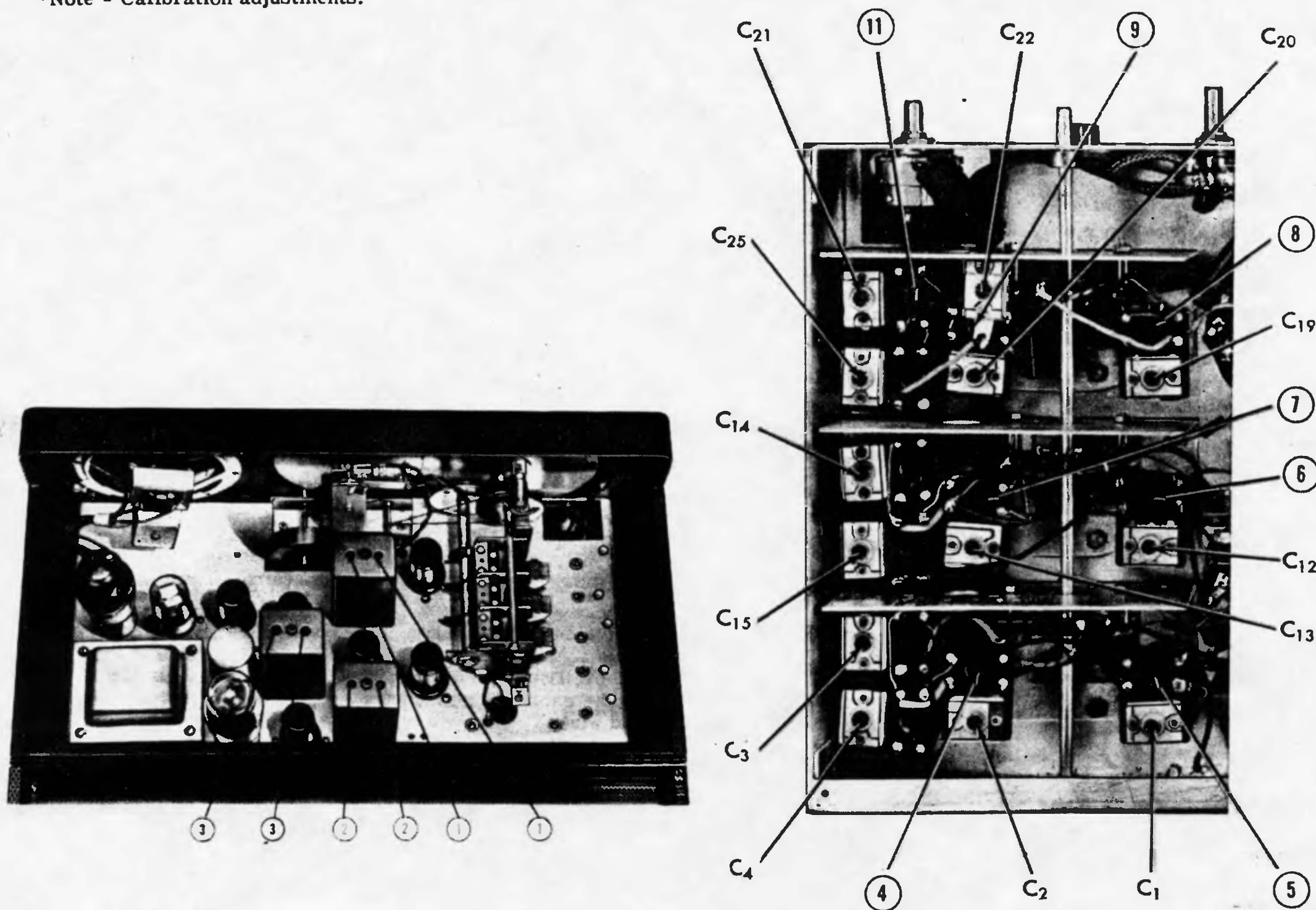

Fig. 2. Top and bottom view, alignment adjustment

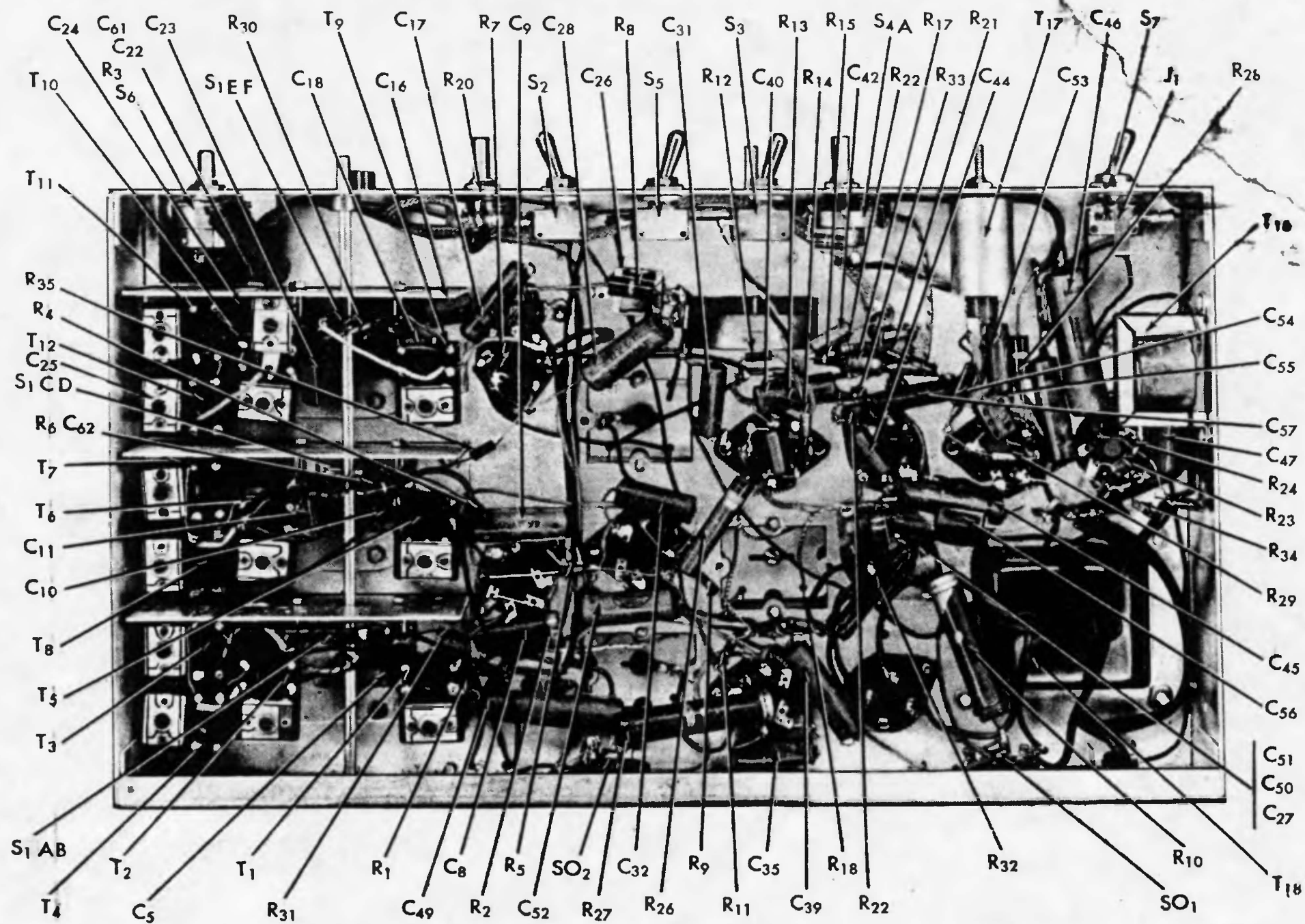

Fig. 3. Bottom view, component location

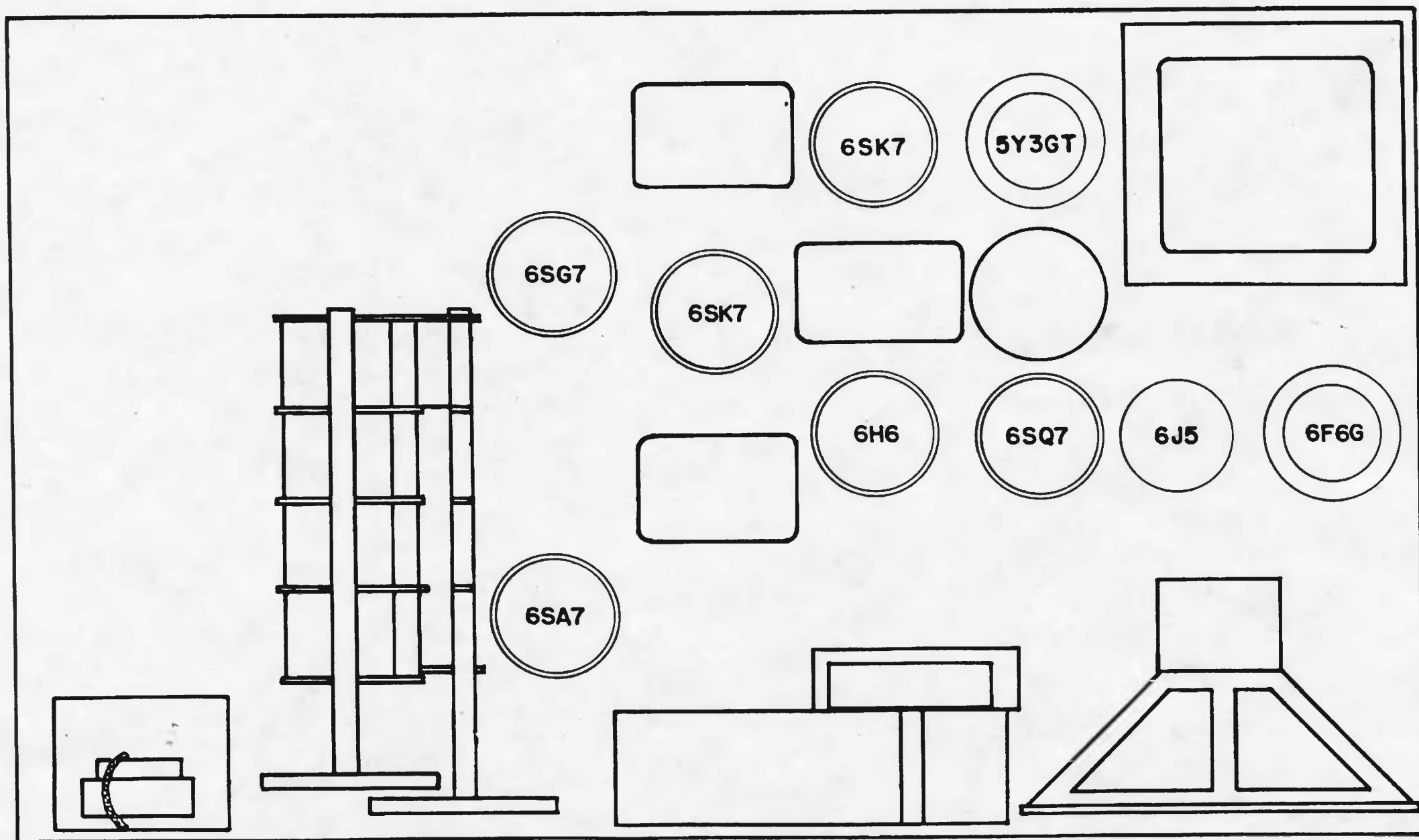
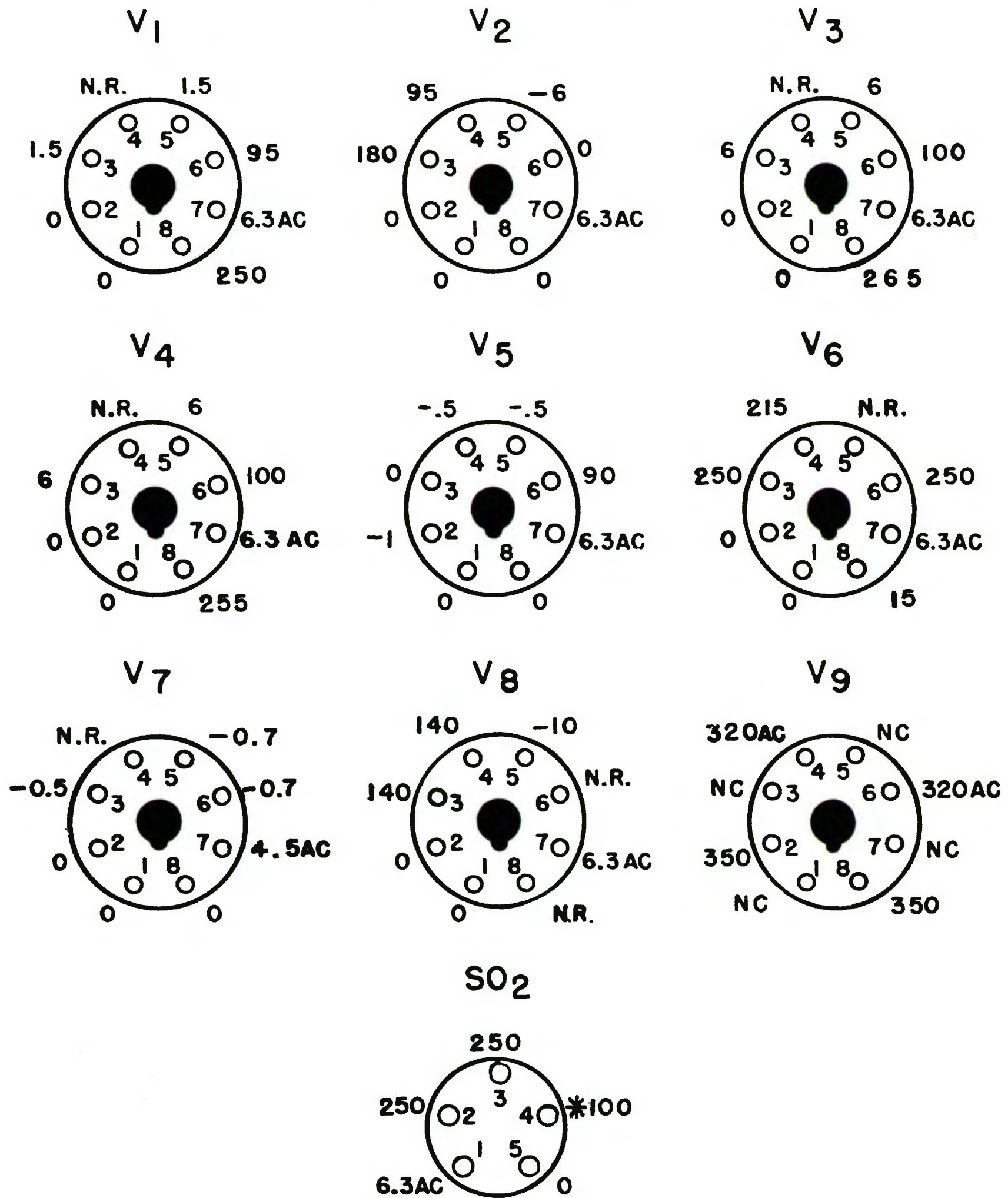

Fig. 4. Top view, tube location

# TUBE TERMINAL VOLTAGES (PIN VIEW)

ALL VOLTAGES ARE POSITIVE DC UNLESS OTHERWISE SPECIFIED



\* "S" METER SWITCH CLOSED (MAX. CLOCKWISE);  
 NR - NOT READABLE WITH METER USED.  
 ALL READINGS TAKEN AT 117V. AC LINE VOLTAGE; WITH  
 20,000 OHM/VOLT METER; NO SIGNAL BEING RECEIVED;  
 CONTROLS SET AS FOLLOWS: STANDBY/RECEIVE SWITCH AT  
 "RECEIVE"; AVC, NOISE LIMITER AT "ON"; AM/CW SWITCH  
 AT "CW"; SENSITIVITY AND VOLUME CONTROLS FULL CLOCKWISE;  
 TUNING, PITCH CONTROL AND TONE CONTROLS IN ANY  
 POSITION AS THEY DO NOT AFFECT READINGS. BAND SELECTOR  
 SET AT BAND I.  
 NC - NO CONNECTION.

92B312

Fig. 5. Tube socket voltage chart

# SERVICE PARTS LIST

Ref. No.	Description	Manufacturer's Part Number	Ref. No.	Description	Manufacturer's Part Number
<b>CONDENSERS</b>			<b>TRANSFORMERS AND COILS (Cont.)</b>		
C-1,2,12,13,19	Trimmer, adjustable, part of transformers T-1,2,5,6 and 9	44B149	T-12	Transformer, oscillator stage, band 1	51B912
C-3,4,14,15,20,21,25	Trimmer, adjustable, part of transformers T-3,4,7,8,10, 11 and 12	44A147	T-13	Transformer, 1st IF	50C185
C-5	.05 mfd. 200 V., tubular	46A091	T-14	Transformer, 2nd IF	50C186
C-6,7	Tuning capacitor, 3 sections ganged	48C138	T-15	Transformer, detector stage	50C192
C-8,32,35,59,60	.05 mfd. 200 V., tubular	46AU503J	T-16	Transformer, audio output	55B093
C-9,28,52	.05 mfd. 400 V., tubular	46AW503J	T-17	Transformer, BFO	54B033-2
C-10	24 mmf. 500 V., ceramic	47X21UK240M	T-18	Transformer, power	52C140
C-11	15 mmf. 500 V., ceramic	47X21UK150M	*T-18	Transformer, power (universal)	52C139
C-16	390 mmf. 500 V., mica	47X20A391K	<b>SWITCHES</b>		
C-17,53	.01 mfd. 400 V., tubular	46AW103J	S-1	Bandswitch assy, ant. and mixer	62B039
C-18	68 mmf. 500 V., ceramic	47X25UK680K	S-2,3,5,7	Bandswitch ass'y, oscillator	62B044
C-22	Trimmer, adjustable	44A191		Switch, toggle, S.P.S.T., STANDBY-RECEIVE, A.V.C., A.N.L., and CW-AM	60A138
C-23	3,000 mmf. 500 V., mica	47X30C302K	S-4	Switch, PWR-TONE control	60A225
C-24	1500 mmf. 500 V., mica	47X30C152J	S-6	Switch, part of SENSITIVITY control R-3	
C-26	3 mmf. temperature compensator for osc. stage	44A158	<b>PLUGS AND SOCKETS</b>		
C-27,50,51	30-10-10 mfd. 450 V., electrolytic	45A062	J-1	Jack, headset	36A002
C-31,43,58	.02 mfd. 200 V., tubular	46AU203J	PL-1	Line cord	87B1573
C-38	2 mmf., twisted wire gimmick		PL-2	AC shorting plug	35A003
C-39,45,48	.02 mfd. 600 V., tubular	46AY203J	SO-1	Socket, POWER (DC operation)	6A035
C-41,42,55	47 mmf. 500 V., mica	47X20A470M	SO-2	Socket, "S" meter connection (5 prong)	6A186
C-44	270 mmf. 500 V., mica	47X20A271K		Socket, octal (tube)	6A035
C-46	10 mfd. 25 V., electrolytic	45A121		Socket, dial light, general coverage dial	86B070
C-47	.002 mfd. 1000 V., tubular	46A104		Socket, dial light, bandspread dial	86B049
C-49	.1 mfd. 400 V., tubular	46AV104J	<b>TUBES, RECTIFIERS AND LAMPS</b>		
C-54	470 mmf. 500 V., mica	47X20A471J	V-1	Type 6SG7, antenna	90X6SG7
C-56	.01 mfd. 600 V., molded paper	46AC103J	V-2	Type 6SA7, mixer	90X6SA7
C-57	1000 mmf. 500 V., mica	47X25A102M	V-3,4	Type 6SK7, 1st and 2nd i-f amplifiers	90X6SK7
C-61	.25 mfd. 200 V., tubular	46AT254J	V-5	Type 6SQ7, detector, audio amplifier	90X6SQ7
C-62	2.2 mmf. 500 V., bakelite	47A160-4	V-6	Type 6F6G, audio power amplifier	90X6F6G
<b>RESISTORS</b>			V-7	Type 6H6, gas gate and noise limiter	90X6H6
R-1,15,58	100,000 ohms 1/2 watt, carbon	23X20X104M	V-8	Type 6J5, BFO	90X6J5
R-2	120 ohms 1/2 watt, carbon	23X20X121K	V-9	Type 5Y3GT, rectifier	90X5Y3GT
R-3	10,000 ohms, SENSITIVITY Control	25A533	LM-1,2	Lamp, dial light, Mazda #44	39A003
R-4,31	22 ohms 1/2 watt, carbon	23X20X220M	<b>MISCELLANEOUS</b>		
R-5,18	1000 ohms 1/2 watt, carbon	23X20X102K	TS-1	Terminal strip, antenna	88A032
R-6	6800 ohms 1 watt, carbon	23X30X682K		Lock, line cord	76A299
R-7	18,000 ohms 1/2 watt, carbon	23X20X183K		Shaft, bandswitch and index plate	74B172
R-8	10,000 ohms 2 watts, carbon	23X40X103K		Collar, bandswitch	77A043
R-9	1000 ohms 1/2 watt, carbon	23X20X102M		Bracket, dial drive mtg.	67B503
R-10	12,000 ohms 4 watts, carbon	23X65C123K		Dial shaft, bandspread	74A169
R-11	330 ohms 1/2 watt, carbon	23X20X331K		Drive shaft, main tuning	74A171
R-12,59	2.2 megohms 1/2 watt, carbon	23X20X225M		Drive shaft, bandspread	74A170
R-14,29	47,000 ohms 1/2 watt, carbon	23X20X473M		Washer, spring (Bandswitch bandspread dial, and main tuning drive shafts)	4A043
R-20	1/2 megohm, VOLUME control	25A534		Spring, retainer (Bandspread, and main tuning drive shaft)	75A062
R-21	150 ohms 1/2 watt, carbon	23X20X151M		Flywheel, bandspread tuning	71A178
R-22	270,000 ohms 1/2 watt, carbon	23X20X274K		Pulley, bandspread dial	28A012
R-23,61	470,000 ohms 1/2 watt, carbon	23X20X474M		Dial cord	38A001
R-24	680 ohms 1 watt, carbon	23X30X681K		Spring, dial cord	75A012
R-25	15,000 ohms 1 watt, carbon	23X30X153M		Dial, bandspread	83B254
R-26	12,000 ohms 2 watts, carbon	23X40X123K		Dial, general coverage	83D240
R-27	10,000 ohms 4 watts, carbon	23X65CE103K		Escutcheon, bandspread dial	7B017
R-28	15,000 ohms 2 watts, carbon	23X40X153M		Escutcheon, general coverage dial	7C033
R-30	10 ohms 1/2 watt, carbon	23X10X100M		Glass, general coverage dial	22B199
R-32	1500 ohms 10 watts, WW	24BG152E		Speaker, P.M. (5-inch)	85B050
R-33	15 megohms 1/4 watt, carbon	23X10X156M		Baffle, speaker	63C223
R-34	10,000 ohms 1/2 watt, carbon	23X20X103M		Grill, speaker	7C016
R-35	27 ohms 1/4 watt, carbon	23X10X270K		Knob, PITCH CONTROL	15A058
R-60	330,000 ohms 1/2 watt, carbon	23X20X334K		Knob, SENSITIVITY, VOLUME and TONE	15A049
R-62	1 megohm 1/2 watt, carbon	23X20X105M		Knob, TUNING and BANDSPREAD	15A047
R-63	6.8 ohms 1 watt, carbon	23X30X068K		Knob, BAND SELECTOR	15B053
<b>TRANSFORMERS AND COILS</b>				Foot, rubber	16A007
T-1	Transformer, antenna stage, band 4	51B783	<b>* Used on universal model S-40AU only.</b>		
T-2	Transformer, antenna stage, band 3	51B782			
T-3	Transformer, antenna stage, band 2	51B781			
T-4	Transformer, antenna stage, band 1	51B780			
T-5	Transformer, mixer stage, band 4	51B787			
T-6	Transformer, mixer stage, band 3	51B786			
T-7	Transformer, mixer stage, band 2	51B785			
T-8	Transformer, mixer stage, band 1	51B784			
T-9	Transformer, oscillator stage, band 4	51B791			
T-10	Transformer, oscillator stage, band 3	51B913			
T-11	Transformer, oscillator stage, band 2	51B789			

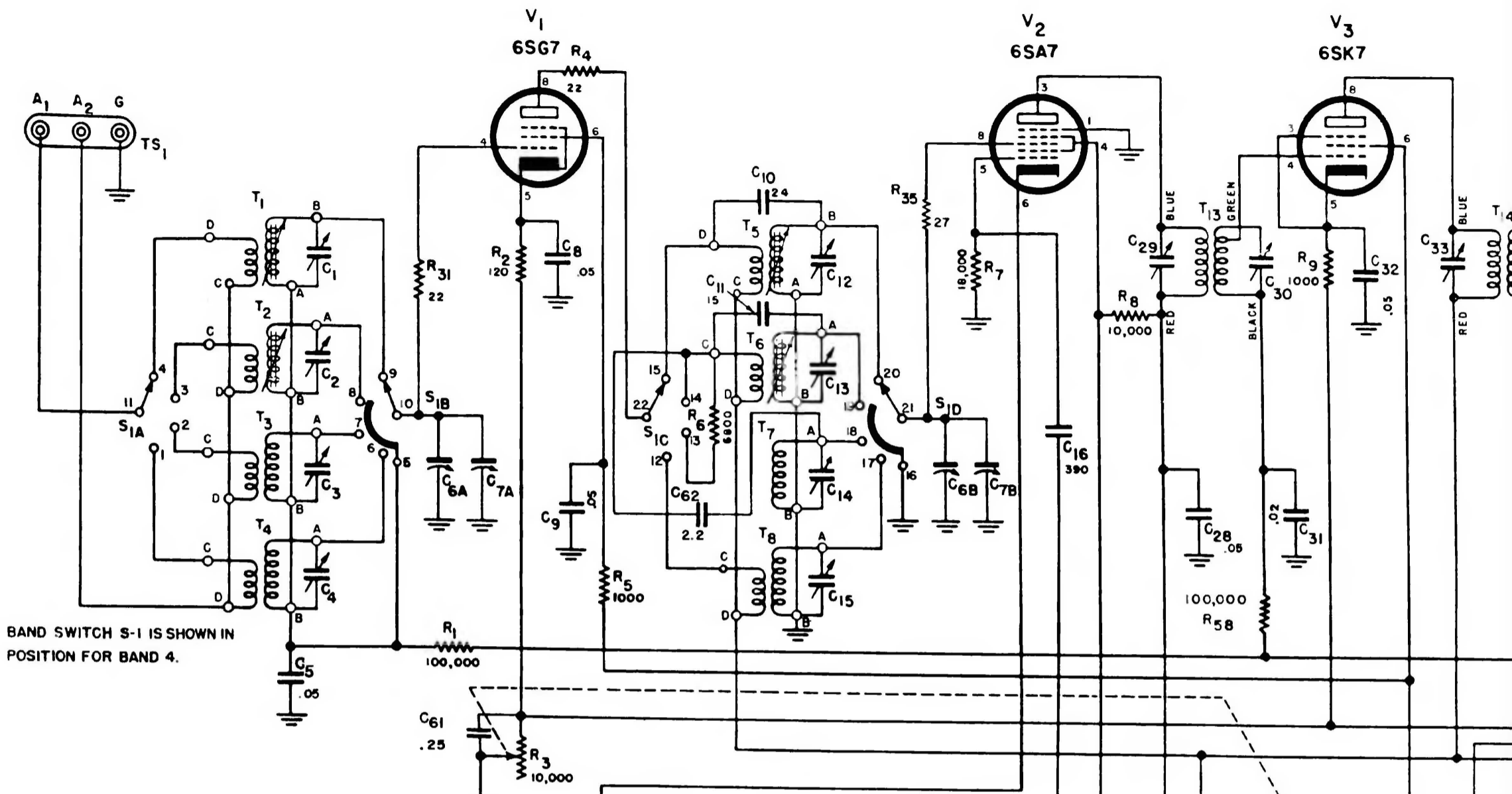

BAND SWITCH S-1 IS SHOWN IN POSITION FOR BAND 4.

**NOTE.**

RESISTANCE VALUES ARE IN OHMS, MICA CAPACITOR VALUES ARE IN MMF, PAPER CAPACITOR VALUES ARE IN DECIMAL EQUIVALENTS OF MFD, ELECTROLYTIC CAPACITOR VALUES ARE IN MFD.

DENOTES MECHANICAL GANGING

NUMERALS AT BANDSWITCH (S<sub>1</sub>) AND LETTERS AT ANTENNA, MIXER AND OSCILLATOR TRANSFORMERS (T<sub>1</sub> TO T<sub>12</sub>) IDENTIFY CORRESPONDING TERMINAL LUGS ON PICTORIAL VIEWS.

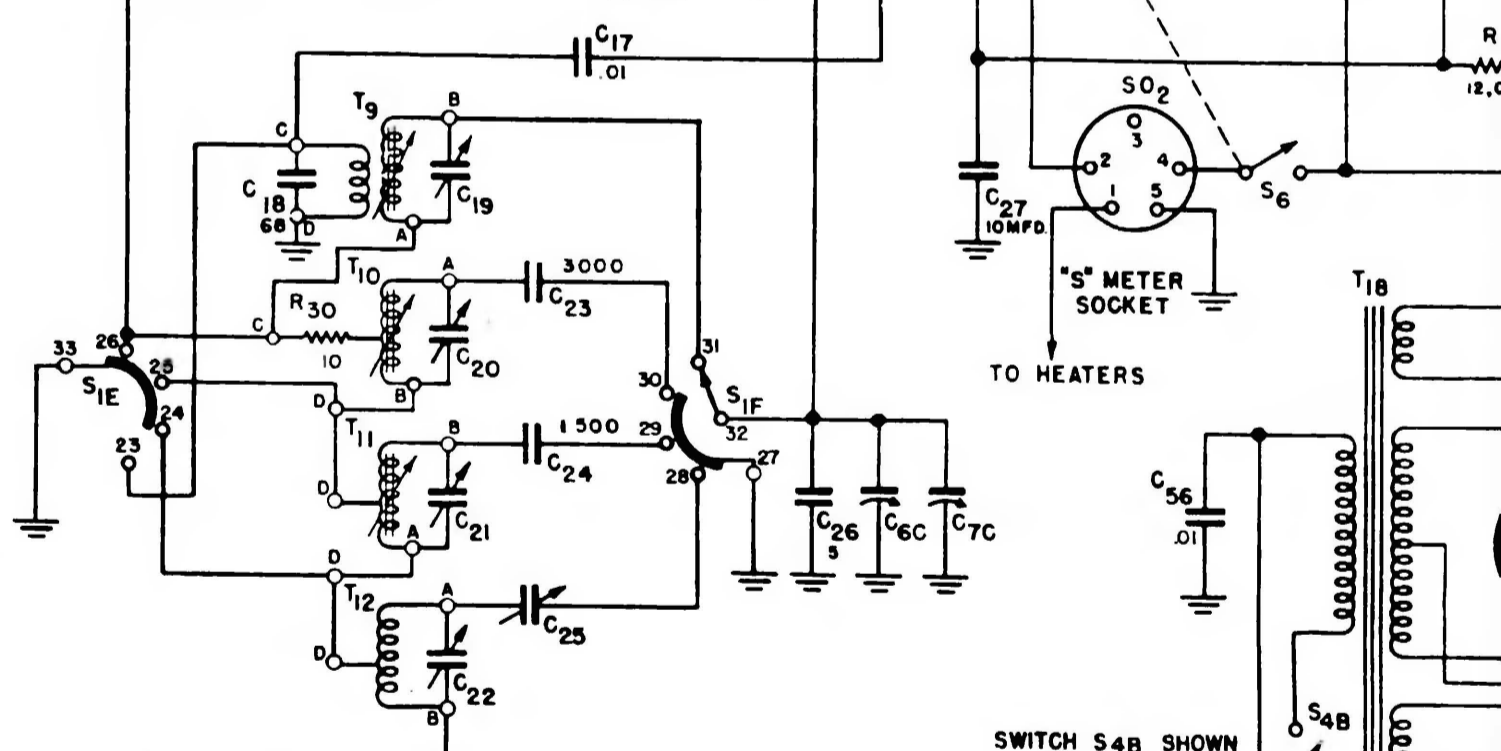

SWITCH S<sub>4B</sub> SHOWN IN POSITION I.

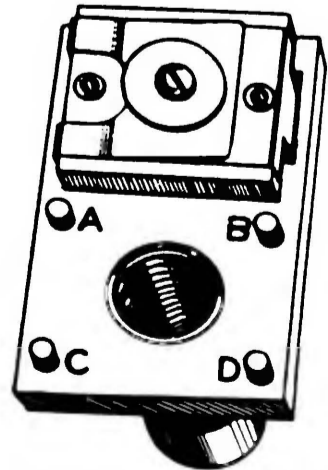
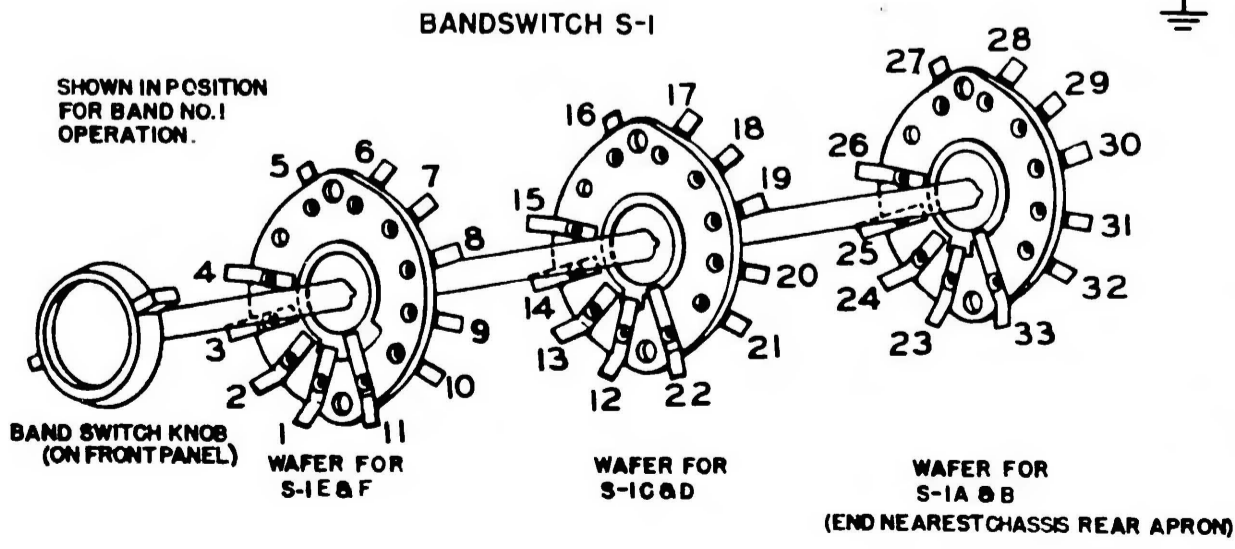

REPRESENTS TRANSFORMERS T<sub>1</sub> TO T<sub>12</sub>

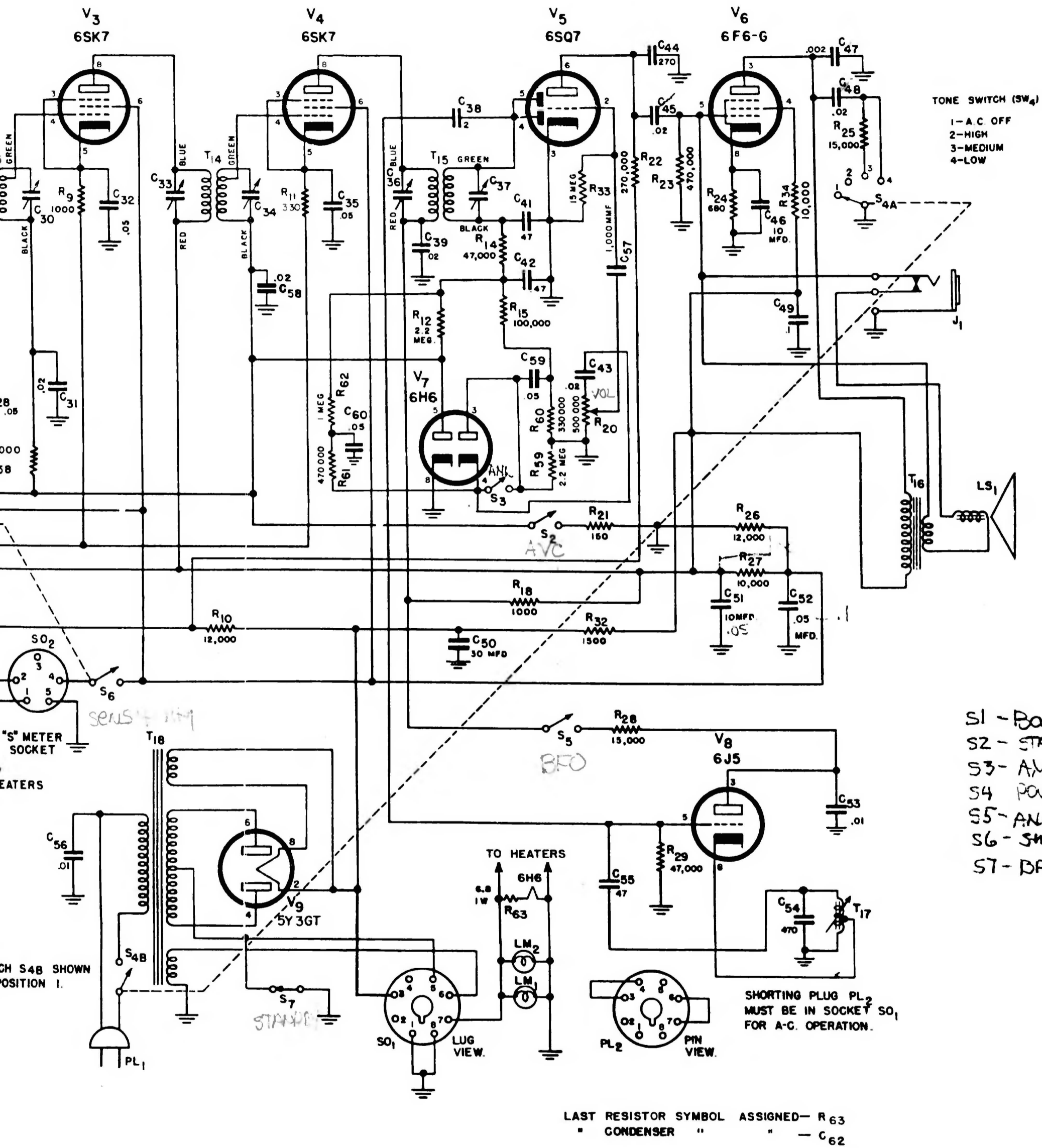

TONE SWITCH (SW<sub>4</sub>)  
 1 - A.C. OFF  
 2 - HIGH  
 3 - MEDIUM  
 4 - LOW

S1 - Bandswhch  
 S2 - STANDBY  
 S3 - AVC  
 S4 Power/TONE  
 S5 - ANL  
 S6 - smeter  
 S7 - BFO

LAST RESISTOR SYMBOL ASSIGNED - R<sub>63</sub>  
 " CONDENSER " " - C<sub>62</sub>

89D222-F

Fig. 6. Schematic diagram.