

Heathkit of the Month: #43
by Bob Eckweiler, AF6C



Heathkit SB-401
HF Ham Band Transmitter

Introduction:

In mid 1968, after finishing college and getting a job, I found myself back on the air using a new Heathkit SB-301 receiver (See Heathkit of the Month #36) and an old Heathkit Apache TX-1 transmitter (See Heathkit of the Month #17). It was obviously a good time to update to the matching SB-401 SSB transmitter (Figure 1). I had already made a few local contacts using the AM and CW capabilities of the old Apache and was ready to upgrade to SSB.

On December 17th I mailed a check to Heathkit for \$285.00 plus \$7.10 for shipping 36 lbs. from Benton Harbor, MI. The SB-401 shipped on December 23rd and was received just before New Year. Assembly commenced almost immediately, following an inventory of the parts.

An overview of the Heathkit SB line of amateur equipment was given in Heathkit of the Month #30) and the reader may want to review it prior to reading this article. The SB-300/SB-400 and later SB-301/SB-401 were styled after the then popular top-of-the-line Collins twins.

The Earlier Heathkit SB-400 Transmitter:

Heathkit introduced the SB-400 SSB/CW transmitter (Figure 2) in early 1964 shortly after it introduced the SB-300. The SB-400 runs 170 watts CW and 180 watts PEP input. It covers 80 meters through the full 10-meter band (no WARC bands in those days). All crystals are provided for operating stand-alone or in transceiver mode with the SB-300 receiver. The SB-400 sold for \$325.00. The only accessory sold for the SB-400 was the HDP-21 microphone.



Figure 1: Heathkit SB-401 Transmitter

The Heathkit SB-401 SSB/CW Transmitter:

In 1966 Heathkit upgraded the SB-400 to the SB-401; at the same time it also upgraded the SB-300 to the SB-301. The SB-401 sold for \$285; it was produced into 1976 when the stand-alone transmitter and (by then SB-303) receiver were discontinued for the solid-state SB-104 transceiver.

The SB-401 has the same specifications as the SB-400. It is rated at 180 watts PEP input on SSB and 170 watts DC input on CW. No AM option is provided. Output is greater than 100 watts on all bands except 10 where it is rated at 80 watts. SSB carrier suppression is 55 dB below rated output (About 0.32 mW). Like the SB-400 the SB401 covers 80 through 10 meters in eight 500 KHz wide band-switch positions. Four of those 500 KHz segments positions are dedicated to cover the full 10-meter band.

Differences Between the SB-400 & SB401:

Most notably, Heathkit lowered the price of the revised transmitter by \$40. A significant reason for the lower cost was the SB-401 no longer



Figure 2: Heathkit SB-400 Transmitter

included the complete set of crystals needed for stand-alone operation. Heathkit evidently realized that most of the SB-400 transmitters were being used with an SB-300, and both the SB-300 and SB-301 provides the needed frequencies to operate the SB-401 in both transceiver and split modes except on CW. Thus all but one of the crystals are redundant if either transmitter is used with the SB-300 or SB-301. For those who want to operate the SB-401 with a different receiver, Heathkit offered the optional SBA-401-1 Crystal Pack for \$29.95. (See Table 1)

Four other significant changes were made to the SB-401: The crystal filter was updated from the 404-200 to the physically smaller 404-283; a chassis mounted CW sidetone oscillator level control (accessible on the upper right of the chassis after lifting the hinged top cabinet cover) was added; the LMO was changed from part #110-13 using a 6AU6 to part #110-32 (and in 1968 to 110-40) both using a 6BZ6 tube; finally a switch, mounted concentric with the **MIC CW LEVEL** potentiometer on the front panel, was added that allows switching between the receiver LMO (Linear Master Oscillator) and the transmitter LMO. On the older SB-400 this switching was inconveniently done by the operator raising the cabinet top and changing a coaxial jumper link.

Optional crystals supplied by the SBA-401-1 Crystal Pack:		
	KHz	Operation
Y1	38,395.0	29.5 MHz Heterodyne Crystal
Y2	37,895.0	29.0 MHz Heterodyne Crystal
Y3	37,395.0	28.5 MHz Heterodyne Crystal
Y4	36,895.0	28.0 MHz Heterodyne Crystal
Y5	29,895.0	21.0 MHz Heterodyne Crystal
Y6	22,895.0	14.0 MHz Heterodyne Crystal
Y7	15,895.0	7.0 MHz Heterodyne Crystal
Y8	12,395.0	3.5 MHz Heterodyne Crystal
Y9	3,396.4	USB Carrier Crystal
Y11	3,393.6	LSB Carrier Crystal
Crystal Supplied with SB-401 Kit		
Y10	3,395.4	CW Carrier Crystal

Table 1 - Optional & Supplied Crystals

Front panel controls are located in three rows.

Left to right on the top row:

FINAL Tuning: Variable Capacitor

Final Loading: Variable Capacitor

← **INC LOAD; 50Ω**
(Concentric with Final Tuning)

MIC CW LEVEL: Dual Ganged Pot
(unnumbered gain scale)

[FREQ. CONTROL* 2 pos. rotary sw. LOCKED (RCVR.), UNLOCKED
(Concentric with Mic CW Level) - SB-401]

Multi-Meter (lighted): meter (0-1 ma)
0 - 10 by 2; **0 - 500** by 100; **ALC** zone

Left to right on the middle row:

DRIVER Tuning: Variable Capacitor
(unnumbered 180° scale)

MAIN TUNING LMO var. capacitor
0 - 5 turns scale, 0 - 100 frequency scale
(both lighted)

METER switch 5 pos. rotary sw.
GRID ma, **PLATE** ma, **ALC**, **HV** x100, **REL PWR**

Left to right on the bottom row:

FUNCTION switch: 5 pos. rotary sw.
OFF, STBY, TRCV, TRAN, SPOT

BAND switch: 8 pos. rotary sw.
3.5, 7.0, 14.0, 21.0, 28.0, 28.5, 29.0, 29.5

MODE switch: 4 pos. rotary sw.
LSB, USB, CW, AM

MIC connector: 2-pin connector

Notes:

[SB-401 differences are shown in brackets]

* Early (or prototype) SB-401 marked LMO MODE

Table 2: SB400/401 Front Panel Controls

There are numerous small circuit changes. The component designations (such as R1 etc.) changed dramatically between models. In most cases the component values remained the same. Unfortunately, the schematic of the SB-400 is not readily available on the Internet so

Connectors are listed from left to right as viewed from the rear.

The left most top connector is an RCA jack:

PATCH: Phone patch audio 600Ω

Below it is a 1/4" phone jack:

KEY Key

AC INPUT: 2-pin male AC socket.

Accessory Socket 9-pin Molex (See text)

Pins 1 to 7: Spare (no connection)

Pin 8: Ext. Ant. Relay 120 VAC

Pin 9: Ext. Ant. Relay 120 VAC

The next ten RCA jacks are mounted vertically in pairs and are listed top then bottom:

RCVR AUDIO: Audio from receiver

SPKR: Audio to speaker

RCVR LMO: Frm SB-300/301 for xcv

ANTI-VOX: To rcvr Hi-Z audio out

HET OSC: Frm SB-300/301 for xcv

RCVR BFO: Frm SB-300/301 for xcv

RCVR MUTE: Audio to Transmitter

SPARE: Not used

LINEAR RELAY: Keys linear amplifier

ALC INPUT: From linear amplifier

The next connector is an SO-239 coax jack:

ANTENNA: RF output

The last two RCA jacks are next to each other:

RCVR ANT: Antenna out to receiver

SPARE: Not used

Table 3: SB-300/301 Rear Connectors

the circuit changes could not be explored more deeply. One known change is R71 in the SB-400 (R402 in the SB-401) was increased from 1/2 to 1 watt. This change is also recommended for the earlier SB-400 in a Heathkit service bulletin.

The front panel of the SB-400 and SB-401 are almost identical with the exception of the added concentric **FREQUENCY LOCK** switch. Table 2 lists the front panel controls with the

No.	Type	Function
V1A	1/2-6EA8	Audio Preamplifier (5)*
V1B	1/2-6EA8	Cathode Follower (3)
V2A	1/3-6AV11	LSB Carrier Oscillator
V2B	1/3-6AV11	USB/CW Carrier Osc.
V2C	1/3-6AV11	Cathode Follower
V3	6AU6	Isolation Amp/ALC Cntl
V4	6EW6	LMO Mixer
V5	6EW6	Heterodyne Mixer
V6	6AU6	LMO #110-13 (SB-400)
V6	6BZ6	LMO #110-32 (SB-401)
V6	6BZ6	LMO #110-40 (SB-401)
V7	0A2	Voltage Regulator
V8A	1/2-6AW8	Heterodyne Osc. (5)
V8B	1/2-6AW8	Rcvr. Het. Osc. Amp. (3)
V9	6CL6	RF Driver
V10	6146	Final Amplifier
V11	6146	Final Amplifier
V12A	1/3-6D10	VOX Amp
V12B	1/3-6D10	Relay Amplifier
V12C	1/3-6D10	Sidetone Amplifier
V13A	1/2-6J11	Anti-VOX Amplifier
V13B	1/2-6J11	Sidetone Oscillator

(3) refers to triode section of tube
(5) refers to pentode section of tube

Table 4: SB-400/401 Tube Line-up

printed nomenclature in bold. Likewise Table 3 gives the rear panel connectors.

CW Operation:

On CW both the SB-400 and 401 transmit on a frequency 1 KHz above the frequency the radio is tuned to. This is so that the transmitted signal will create a 1 KHz note in the receiver. This is true in both transceiver and transmitter modes. The actual CW carrier developed by the carrier generator is 1 KHz low, but is inverted later in the heterodyne mixer, as are the sidebands.

SB-400 and SB-401 Circuit description:

Since the SB-400 and the later SB-401 transmitters are so similar in design, this article will focus on the SB-401 and point out differences in the earlier SB-400 where they occur. The transmitters can be divided into 14 sections:

	Tuned Frequency	BFO Frequency	Bal. Mixer Post Filter	LMO* Frequency	LMO Mixer Output	Heterodyne Oscillator	Het. Mixer - Xmit Freq.
Nom. Oscillator Freq:	28,375.000	(As Shown)	-	5,125.000	-	36,895.000	-
USB							
Carrier (suppressed):	28,375.000	3,396.400	<i>3,396.400</i>	5,123.600	<i>8,520.000</i>	36,895.000	<i>28,375.000</i>
Low Tone - 500 Hz:	28,375.500	3,396.400	3,395.900	5,123.600	8,519.500	36,895.000	28,375.500
High Tone - 2300 Hz:	28,377.300	3,396.400	3,394.100	5,123.600	8,517.700	36,895.000	28,377.300
LSB							
Carrier (suppressed):	28,375.000	3,393.600	<i>3,393.600</i>	5,126.400	<i>8,520.000</i>	36,895.000	<i>28,375.000</i>
Low Tone - 500 Hz:	28,374.500	3,393.600	3,394.100	5,126.400	8,520.500	36,895.000	28,374.500
High Tone - 2300 Hz:	28,372.700	3,393.600	3,395.900	5,126.400	8,522.300	36,895.000	28,372.700
CW							
Carrier (1,000Hz Tone):	28,375.000	3,395.400	3,395.400	5,123.600	8,519.000	36,895.000	28,376.000

Table 5: USB & LSB frequencies in KHz for a two-tone (500 Hz & 2,300 Hz) signal, and for a CW signal, as they appear within a properly tuned SB-401 (See Text). Frequencies in *italic red* are suppressed by the balanced modulator as well as the crystal filter and are shown for reference only. * See LMO circuit description.

The power supply; the balanced modulator including the speech and isolation amplifiers; the carrier generator; the crystal filter; the LMO; the LMO mixer; the heterodyne oscillator and buffer; the heterodyne mixer, the RF driver; the final amplifier; ALC; metering circuits, the sidetone generator and the VOX T/R circuits. The SB-400/401 uses 13 tubes. they are shown in Table 4 and listed in each section header. A block diagram for the SB-401 is included at the end of the article (Figure 4).

1. Power Supply (V7):

The power supply is transformer based. SB-400 and early SB-401 kits came with a transformer (#54-143) that had a single 120V primary. Later units came with dual primary windings (#54-198) that could be wired for 120 or 240 volt operation. This change is believed to have occurred in the early fall of 1968.

The secondary of both transformers appear similar with three tapped windings. The filament winding provides 12.6 VAC with the center-tap grounded. One-half the winding provides 6.3V for the two 6146 final tube filaments as well as the driver tube. The other half

provides 6.3V filament voltage to the rest of the tubes and the dial and meter pilot lamps.

All power supply rectifiers employ silicon diodes. The high voltage winding supplies around 275 VAC power to a full-wave voltage doubler. Two 125 μ F capacitors are effectively in series providing 63 μ F of filtering, providing good regulation and 720 VDC at 250 ma load for the final amplifier tubes.

The third winding provides low voltage and negative bias power. The low end of the windings is grounded and a tap at about 95 VAC drives a half-wave voltage doubler. Two large filter capacitors and a heavy choke provide a low-ripple 250 volts DC at 100 ma to most of the circuitry. Power for the LMO and crystal heterodyne oscillator is regulated at 150 volts by V7, an 0A2 gas voltage regulator tube.

The full third winding provides about 125 VAC to a capacitor input RC filter supplying -170 VDC. Multiple resistive dividers provide negative bias voltages to numerous stages including adjustable bias to the final amplifier tubes.

2. Audio & Balanced Modulator (V1A,V1B, V3):

Audio from a high impedance microphone or a separate 600Ω phone-patch jack is fed into the audio preamplifier, the pentode section of V1, a 6EA6 dual-section tube. The audio is filtered to limit RF as well as high and low frequency audio from reaching the amplifier. Output from the amplifier is sent to the VOX circuit as well as the triode section of the 6EA8 through the **MIC LEVEL** control. The triode is a cathode follower designed to match the low impedance of the balanced modulator.

Low-level RF from the carrier generator (to be discussed next) is fed into a balanced circuit consisting of four crystal diodes and an RF transformer. A capacitor and internal pot are adjusted to balance the circuit so no RF appears in the secondary of the transformer. When audio is applied, the bridge is unbalanced and two RF signals are produced; one is the sum of the carrier and the audio and one is the difference of the carrier and audio. These are the two sidebands, upper and lower. On CW no audio is present but a DC voltage is applied to the balance modulator allowing the carrier to be present at the output. This voltage is adjusted by the **CW LEVEL** that is ganged to the **MIC LEVEL** control.

The signal from the balanced modulator is amplified by V3, a 6AU6. this stage performs multiple functions. The stage gain is controlled by the ALC circuit, reducing output in response to any overdriving condition. This stage also matches the signal impedance to the next stage - the crystal filter.

3. Carrier Generator (V2):

The carrier generator is a crystal oscillator that can produce one of three frequencies in the 3,395 KHz range depending on whether the transmitter is set for USB, LSB or CW. The SB-400 comes with all three crystals, while the SB-401 has only the CW crystal, the others being part of the optional crystal kit. Both transmitters use the receiver BFO crystal signals when in transceiver mode on SSB. On CW the trans-

mitter crystal is used since it is 1 KHz different in frequency than the receiver CW BFO crystal. On LSB the carrier signal is 3,393.6 KHz; on USB it's 3,396.4 KHz and on CW it is 3,395.4

It is interesting to note that the carrier frequencies are such that when in USB the balanced modulator and filter actually produce a LSB signal and vice-versa. The reason is because the sidebands are inverted in the later heterodyning process effectively swapping the two sidebands and producing the desired output.

The carrier generator uses a 6AV11 triple triode tube (V2). One section is the oscillator for the LSB crystal (if installed), the second section is the crystal oscillator for the USB crystal, (if installed), and the CW crystal when in CW or Tune mode. The third section is a cathode follower that buffers the crystal oscillators or the transceive carrier signal from the receiver.

4. The Crystal Filter:

The crystal filter performs an important SSB function; it allows only one of the two sidebands to pass while rejecting the other sideband and also further reducing any remaining carrier signal. The output from the balanced modulator, contains the audio signals, the upper and lower sideband signals around the car-

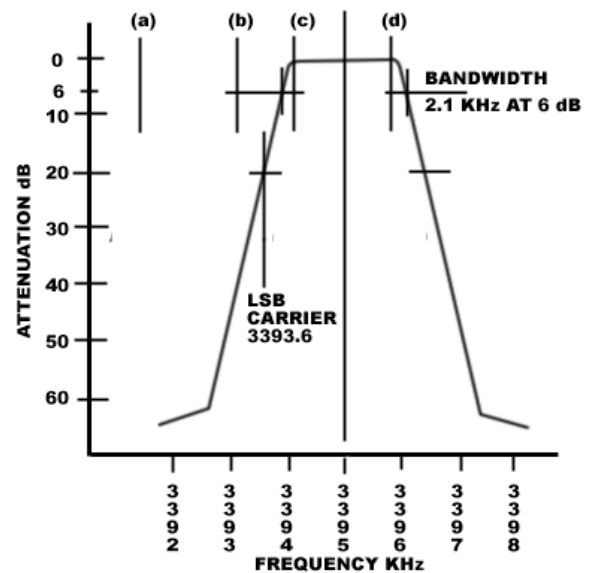

Figure 3a Crystal Filter in LSB Mode

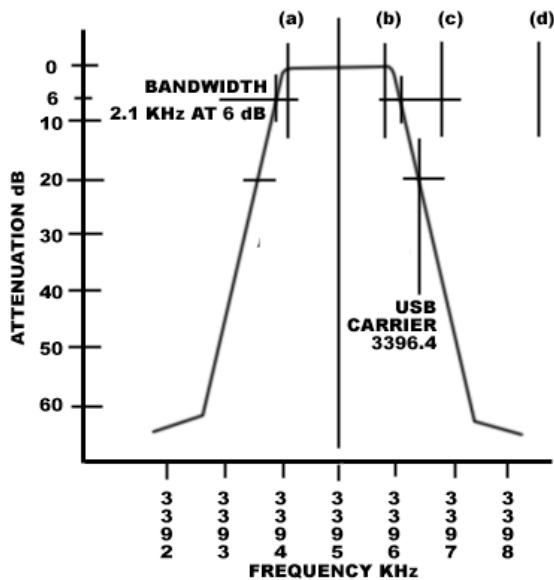

Figure 3b Crystal Filter in USB Mode

rier frequency and any residual carrier that is not balanced out. The audio is too low to pass the balanced modulator transformer. The remaining signals are fed to the crystal filter. Figures 3a, 3b and 3c show how the filter handles a two tone SSB signal modulated at 500 and 2,300 Hz. This signal is composed of the carrier signal (heavily suppressed by the balanced modulator), a signal (c) 500 Hz above the carrier, a signal (b) 500 Hz below the carrier, a signal (d) 2,300 Hz above the carrier and a signal (a) 2,300 Hz below the carrier.

Figure 3a shows the LSB signal. The filter further suppresses any carrier not suppressed by the balance modulator at 3,394.6 KHz by 20 dB as well as suppressing the sideband signals at 3,394.1 KHz (b) and 3,391.3 KHz (a) while passing the sideband signals at 3,395.1 KHz (c) and 3396.9 KHz (d). As stated earlier, this is really an upper sideband signal which will be inverted later.

Figure 3b shows the same function for the USB signal. The carrier is at 3,396.4 KHz and the tone are at (a) 3,394.1 KHz, (b) 3,395.9 KHz, (c) 3,396.9 KHz and (d) 3,398.7 KHz. Again the carrier is further suppressed by the filter as are the signals at (c) and (d), while the (when inverted) USB signals at (a) and (b) are passed.

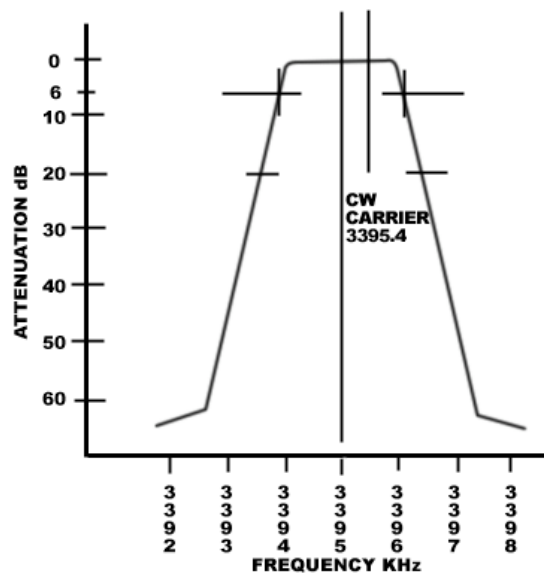

Figure 3c Crystal Filter in CW Mode

For completeness, Figure 3c shows the CW carrier which passes easily within the bandpass of the filter at 3,395.4 KHz.

The SSB output of the filter is a complete USB or LSB signal and only needs to be heterodyned to the correct frequency, inverted and amplified.

5. Linear Master Oscillator (V6):

The LMO was discussed in the SB-301 article and will be covered lightly here. It covers a nominal frequency from 5.5 MHz when tuned to the low end of a band to 5.0 MHz when tuned to the high end of a band. The actual frequency is either 1.4 KHz above or 1.4 KHz below that frequency depending on whether you are in LSB, or USB-CW. This shift is determined by a voltage applied to the bias terminal of the LMO.

6. LMO Mixer (V4):

The signal from the crystal filter is mixed with the output of the the LMO in V4, a 6EW6 pentode. Either the LMO from the receiver or transmitter is used depending on the **FREQUENCY CONTROL** switch position on the SB-401. On the earlier SB-400, this switching is done by moving a coaxial jumper. Only the sum product of the LMO mixer's output passes through a factory-tuned coupler transformer with a bandpass of 8.395 to 8.895 MHz.

7. Heterodyne Oscillator Buffer (V8A, V8B):

The heterodyne oscillator generates the frequency needed to heterodyne the output from the LMO mixer to the final frequency. In transceiver mode the heterodyne signal is created in the receiver and buffered in the transmitter by the pentode section of V8(A), a 6AW8. In the transmit mode the triode section of V8(B) is a crystal oscillator that generates the heterodyne signal in the SB-400 (and SB-401, assuming the crystal pack option is installed). Table 1 lists the heterodyne frequencies.

8. Heterodyne Mixer (V5):

The 6EW6 heterodyne mixer mixes the heterodyne oscillator and LMO mixer output signals. The desired product is the difference between the two signals. In the process the sidebands are inverted. The unwanted sum product, which is ~17 MHz above the desired product, is easily filtered out in the plate circuit, which is tuned by coils, switched for each band and a variable capacitor, which is one section of the **DRIVER** tuning capacitor.

9. Driver Stage (V9):

The driver stage is a 6CL6. It amplifies the desired signal to the level needed to properly drive the final amplifier tubes. The plate circuit is tuned by coils switched by each band in conjunction with a section of the **DRIVER** tuning capacitor.

When operating near the high end of 40 meters an unwanted 8.6 MHz signal may be present. This is generated by the LMO and leakage of the BFO summing in the mixer. This signal is removed by a series tuned LC trap in the grid circuit of V9.

RF energy is coupled from the plate circuit of the final amplifier to the B+ end of the driver plate coils. This energy is reduced significantly by a small coupling capacitor in series with a trimmer capacitor. This "neutralization" circuit, when adjusted properly, cancels the effect of the plate to grid capacitance on the final tubes improving stability. An RF choke keeps the energy

from being shunted by the low power supply impedance.

10. Final Amplifier (V10, V11):

The final amplifier uses two 6146 beam-power pentodes in parallel operating as linear class AB1 Amplifiers. Power input is 180W PEP on SSB and 170W on CW. Power output is on the order of 100W on 80 through 15 meters and 80W on 10 meters.

An operating bias of about -50V produces a resting plate current of 25 ma per tube. In standby mode, instead of raising the negative bias, the tubes are cutoff by removing the screen voltage. (See modifications section).

The plate circuit of the final amplifier uses a standard pi-network. Tuning and loading are performed by a 250 pF high-voltage variable capacitor and a 245/245/354 pF variable capacitor respectively. On 20, 15 and 10 meters just the two 245 pF sections are used. On 40 and 80 all three sections are used. An additional fixed loading capacitance of 100 pF and 200 pF are also added on 40 and 80 meters respectively. A tapped silver plated tank coil on a ceramic form in series with a separate 10 meter air coil provides the tuning inductance. A wafer on the band-switch selects the proper coil segment shorting the remaining segments out.

11. Automatic Level Control (ALC):

When the final tubes are over-driven in SSB they start to draw grid current. This current varies at the audio rate and it is rectified and the resulting negative voltage is applied to the grid of the isolation amplifier V3 reducing the overall gain. ALC voltage from an external linear amplifier can be input on the rear panel of the transmitter and provide additional limiting voltage to the isolation amplifier.

12. Metering Circuits:

The lighted front panel multi-meter measures five parameters via a 0 – 1 mA meter with an internal resistance of 100Ω:

GRID current - (0 - 1 mA full scale). is measured by switching the meter in parallel with a fixed 4.7K Ω resistor that is in the grid circuit. The resistor is so large in relation to the meter resistance that it is effectively swamped out. Normal grid current is on the order of 0.1 mA on SSB and 0.5 mA on CW.

PLATE current - (0 - 500 mA full scale). A group of six 10-ohm resistors in parallel, and well bypassed, are in the cathode of the final tubes. These resistors drop about 0.85 volts with a plate current of 500 mA. The 100 Ω meter in series with a 750 Ω resistor will read full-scale when the cathodes are at 0.85 volts. Normal plate current peaks at about 250 mA on SSB and CW.

ALC - (arc from 0 to 1/2 of full scale). In this position the meter is placed in a bridge circuit between the screen grid and the cathode resistor of the isolation amplifier. An adjustment pot allows the meter to be set to zero when the tube is operating without any ALC bias. As ALC voltage is applied the cathode becomes less positive and the meter begins to read. When the transmitter is in standby a large negative bias is applied to cutoff the tube. This results in no cathode current and the meter reads full scale or more. During SSB operation the MIC LEVEL should be set so the meter peaks at or below half scale on the meter to prevent distortion and adjacent channel interference.

High Voltage - (0 - 1,000V full scale). A 500 K Ω resistor is placed in series with the meter turning it into a 0 - 500 V voltmeter. This measures the voltage at the center-tap of the voltage doubler of the high-voltage power supply, effectively measuring the high voltage which is double the reading. A 10K Ω resistor shunts the meter to limit high voltage on the circuit when the meter is switched to a different position. the resistance is so large compared to the meter that it doesn't affect the reading.

REL PWR - (0 - 10 units full scale) A sample of the RF at the antenna jack is attenuated, rectified, and fed through an internal adjustment pot to the meter. The pot is adjusted for near full scale indication on the 80 meter band.

13. Sidetone Oscillator & Amplifier (V13B, V12C): The Sidetone oscillator produces an approximately 1,000 Hz tone when in CW and the key is pressed. This allows the operator to monitor his code sending. V13B (1/2 of a 6J11 dual pentode tube) is used as a phase-shift oscillator. The phase shift is determined by a printed electronic circuit in the feedback circuit. The oscillator is normally biased off with a large negative bias that is grounded whenever the key is pressed. When not in the CW mode, the cathode of V13B is opened disabling the circuit.

Output of the sidetone oscillator is coupled to the sidetone amplifier V12C (1/3 of a 6D10 triode triode tube). The amplifier is coupled through an audio transformer and a sidetone level internal pot to a set of contacts on the T/R relay that switches the external speaker between the sidetone audio and the receiver audio. The adjustment pot was not used on the SB-400. Audio from the amplifier is also coupled to the VOX circuit to allow "break-in" operation, switching to transmit when the key is pressed.

14. VOX Circuits & TR Relay (V12A, V12B, V13A): The VOX circuit controls the switching of the radio between receive and transmit in all modes. Switching is done with a six-pole relay in the plate circuit of V12B, a triode relay amp. The cathode is biased positive by a resistive divider resulting in the tube being normally cut-off. However, the tube can be made to conduct and actuate the relay by either grounding the cathode or applying a small positive voltage to the grid. In USB and LSB the cathode is connected to the push-to-talk (PTT) line; it is grounded directly in the tune position. In SSB audio from the VOX circuit is rectified by a diode and fed to the grid causing the relay to op-

erate. A long time-constant adjustable RC circuit keep the relay closed for a length of time; this is the VOX delay control. The diode prevents the time constant from discharging back through the VOX circuit.

Audio from the mic preamplifier (V1A) is fed through the **VOX GAIN** internal control to the VOX amplifier V12A, a triode section of a 6D10 tube. The audio from the sidetone generator is also coupled to the input of the tube. The output of this stage is coupled to the relay amp so when a sidetone is generated in CW or mic audio is present in SSB the relay switches to transmit.

To prevent extraneous receiver audio from tripping the relay, V13A operates as an anti-VOX circuit. Audio from the receiver is amplified by the other pentode section of the 6J11 tube acting as an amplifier. It is AC coupled to a diode which rectifies the receiver audio into a negative voltage. This voltage is fed in parallel with the output of the VOX amplifier bucking any audio present on both the receiver and microphone. An internal **ANTI-VOX** control adjusts the level of the receiver audio reaching the anti-VOX amplifier.

The TR relay has six poles of contacts that, when energized:

1. Switches AC line voltage to an accessory socket for an external antenna relay.
2. Applies screen-grid voltage to the finals and operates the internal antenna relay.
3. Opens the receiver **RCVR MUTE** jack and grounds the **LINEAR RELAY** jack.
4. Switches the grid bias for the isolation amplifier from cutoff bias to the ALC line in SSB and to ground in CW.
5. Removes cutoff bias to the final driver in SSB and connects the bias to the key jack in CW.
6. Disconnects the **SPKR** jack line from the **RCVR AUDIO** jack line and connects it to the sidetone generator output.

Assembling the SB-401:

This is an advanced kit and assembly takes some time. Due to six-night work weeks and other obligations almost a month passed before the transmitter was completed and checked out. Assembly was straightforward and the manual instructions clear, making time spent in assembly as much fun as the later operating.

Parts are shipped sorted in five separate packs; the kit is assembled in five sections. Each section has its own parts list and, except for the larger parts, its own pack. Assembly is eased somewhat by two printed circuit boards that are assembled first. Pack one is for the Mixer Bandpass circuit board that contains the LMO and heterodyne mixers - V4 and V5. Pack two is for the Carrier Generator circuit board that contains the speech amplifier, balanced modulator, isolation amplifier, VOX/T-R and sidetone circuits - V1, V2, V3, V12 and V13. Pack three contains parts for the chassis assembly and initial wiring. Pack four contains parts for the majority of the chassis wiring. And pack five contains parts for the final wiring along with the larger parts that don't fit in the smaller packages. The kit is well shielded and assembly includes installing compartment shields, many of which contain components. This adds to chassis rigidity, a plus for frequency stability.

Initial Test and Alignment:

Plugging in a newly completed kit is always an exciting moment; something rarely experienced by the instant gratification folk. Before powering up, however, Heath, in its manual leads you through a series of resistance checks. These test for major shorts that could result in significant damage. Once plugged in and turned on, voltages are checked. If all appears well, then it is time to move on to alignment.

Alignment requires a VTVM (also used for the initial test) along with an RF probe for the VTVM such as the Heathkit #309C, a dummy load such as the Heathkit Cantenna, a receiver and a hi-Z microphone. Coil and capacitor adjustment tools are included with the kit.

You are given two choices for alignment; one uses an SB-301 receiver, the other the optional SBA-401-1 crystal pack. Both are identical except for heterodyne and carrier oscillator sections. Alignment is straightforward using the chosen SB-301 method, and all went well until the final stage was reached!

This is the only time that I recall building a Heathkit that didn't operate right off the bat. When the transmitter was first set to transmit a sizzling noise was heard and sparks were seen in both of the 6146 final tubes. Power was quickly removed; a check showed that the antenna relay was wired improperly resulting in no load on the transmitter. It was quickly fixed and the tubes inspected. There were a few little balls of once molten metal rattling around in each final tube; but I had no spares so they were plugged back into their sockets and the transmitter cautiously powered up. Surprisingly, the transmitter worked and the tubes still gave full output. I used those tubes for years without changing them, though a new set of spares went on the shelf within a few days of encountering the problem.

Modification & Upgrades:

Over the life of the SB-400 and SB-401 there have been some upgrades that Heathkit has quietly introduced into the SB-401. Most of these are included in the Heathkit SB-401 service bulletins, which can be found online at:

<https://puck.nether.net/pipermail/heath/1998-June/029701.html>

One modification that Heathkit recommended, and I made, solved a long time problem; when switching from transmit back to receive the antenna relay would hang causing me to miss the first few seconds of reception. This is most notable after the radio gets hot. It turns out that the antenna relay is powered by the screen grid voltage supply. This voltage is switched by the T/R relay. As the final tubes age they get gassy resulting in enough secondary emission from the screen grid to keep the antenna relay closed. The solution is simply to add a jumper from the formerly unused NC contact of that

relay section (pin 7) to ground. This grounds the screen grid in receive instead of just leaving it open. Gassy tubes are often still able to put out full power so changing them would be an expensive and temporary solution.

Operation:

The SB-401, along with its companion SB-301 receiver provided good service here in the shack for more than 25 years. The original finals are still installed and when last checked it still exceeded 100 watts out on 15 meters. The transmitter never required repair, though it has been removed from the case and dusted more than once. The switch contacts and relay contacts were usually cleaned at the same time. The radio was used to work DXCC and worked well in the split and transceiver modes. The optional crystal pack was never installed nor needed. Stability, CW note and audio quality have always been reported as very good. It's hard to believe that the radio is approaching 44 years of use. It was recently put back on the air while the TS-440s was being repaired. Other than missing the noise blanker and being a few hundred cycles off the 28.375 MHz net frequency, it worked just fine.

Next Month:

This month's article was quite long, there was a lot to cover. Next month we'll look at a simpler kit from Heathkit's test equipment line.

73, from AF6C



Remember, if you are getting rid of any old Heathkit Manuals or Catalogs, please pass them along to me for my research.

Thanks - AF6C

This article originally appeared in the October 2012 issue of RF, the newsletter of the Orange County Amateur Radio Club - W6ZE.

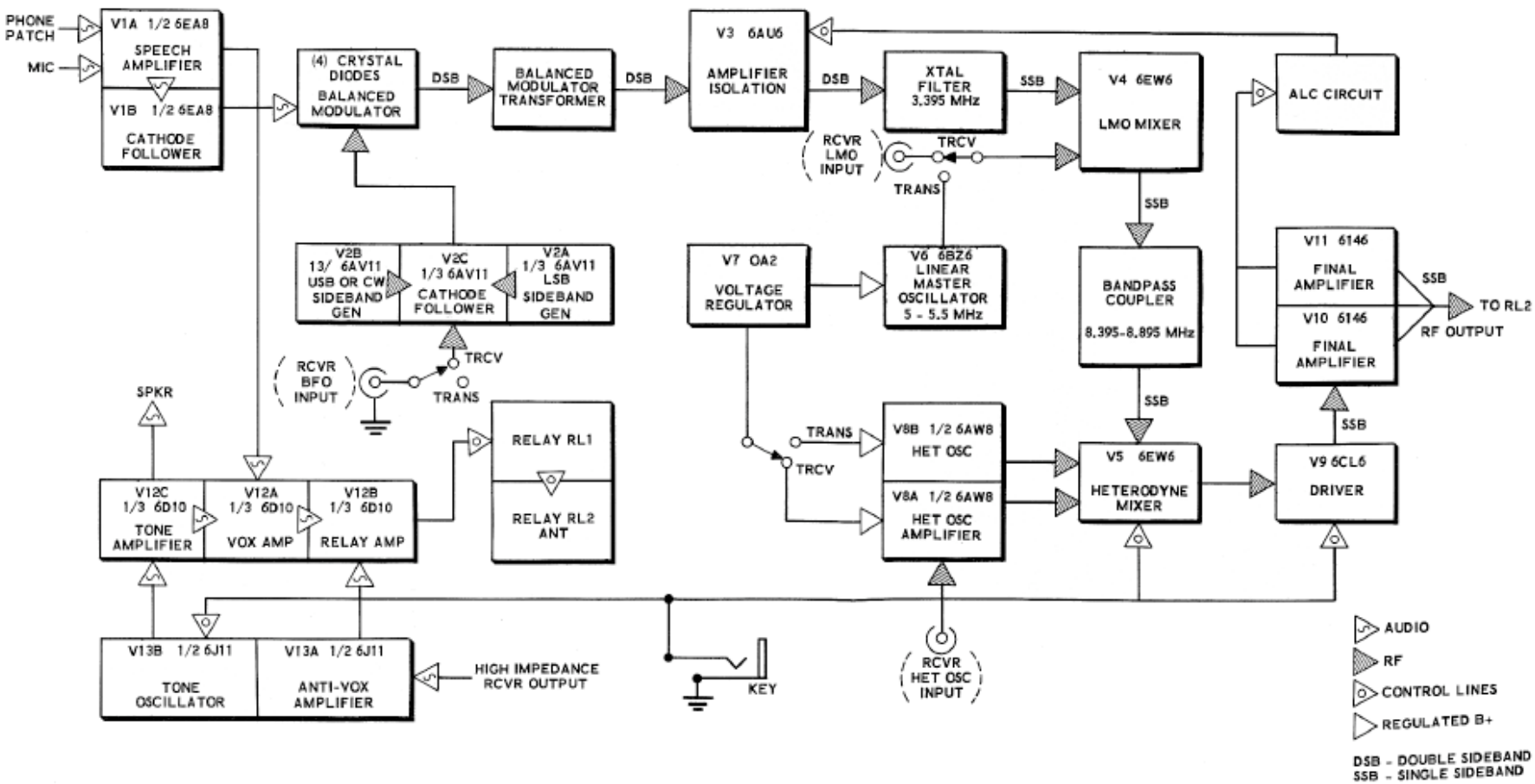

Heathkit SB-401 Block Diagram
 From Early SB-401 Manual
 (Dated: 3/24/67)
 Heathkit Part No. 595-823
Figure 4

BLOCK DIAGRAM