

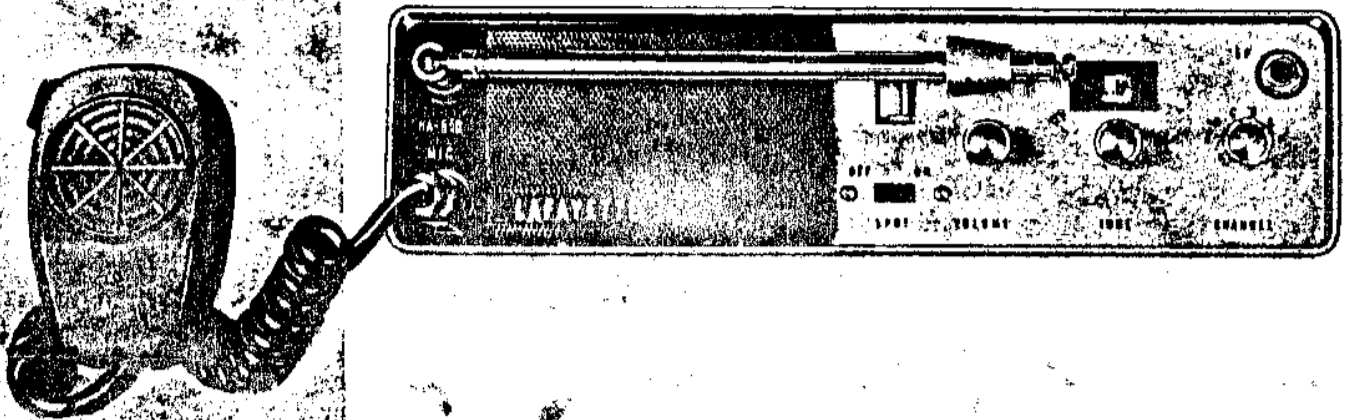

LAFAYETTE®

Model HA-650

Six-Meter Transceiver



Stock No. 99-2570WX

2½ WATT

**PORTABLE and MOBILE
SOLID-STATE TRANSCEIVER**



LAFAYETTE RADIO ELECTRONICS

INSTALLATION AND OPERATING MANUAL

TECHNICAL SPECIFICATIONS

RECEIVER

SENSITIVITY.....	Better than 1.0 μ V for 10 db Signal-to-Noise ratio.
SELECTIVITY.....	6 db down at \pm 3 Kc; 40 db down at \pm 8 Kc.
IMAGE REJECTION	55 db.
SPEAKER IMPEDANCE.....	8 ohms.
RECEIVING CURRENT DRAIN.....	80 ma maximum.

TRANSMITTER

POWER INPUT TO FINAL.....	2-1/2 watts.
MODULATION.....	Class B, full 100% capability.
TRANSMITTING CURRENT DRAIN	400 ma maximum.
TRANSMIT-RECEIVE SWITCHING	Relay (plug-in type).
ANTENNA	50 ohms nominal impedance.
POWER SOURCE.....	Operates from 11.5 to 16.0 volts DC, or with optional 117 volts AC solid-state power supply Model HB-501.

TRANSISTORS	TR-1 thru 5	2SC206	Silicon Mesa
	TR-6, 7	2SB60A	Germanium
	TR-8, 9	2SB324	Germanium
	TR-10, 11	2SC55	Epitaxial Silicon Mesa
	TR-12	2N2951	Epitaxial Silicon Mesa
	TR-13	2N2949	Silicon Planar
	TR-14	2SC580	Silicon Planer

DIODES	D1, 2, 3	1S446	Germanium
	D4	FV-22	Zener
	D5	FV-21	Zener
	D6	FR-1M	Silicon

DIMENSIONS..... 9-1/2" W x 5-1/2" H x 2-1/4" D.

NET WEIGHT..... 9 lbs. with batteries.

IM-408 1-66 IMH

GENERAL INSTRUCTIONS

The Lafayette Model HA-650 Transceiver is designed for use in the 50-52 megacycle segment of the six-meter amateur band. It is illegal to operate the transmitter section of this transceiver prior to receiving a valid station license and call sign issued by the Federal Communications Commission. If you require any information regarding licensing and amateur frequency allocations, contact the Federal Communications Commission (FCC), Washington 25, D.C. or the American Radio Relay League (ARRL), Newington, Conn.

GENERAL DESCRIPTION

The HA-650 is a compact all-transistor transceiver designed for portable or mobile two-way radio communication in the 50-52 MC portion of the 6 Meter Band.

Housed in a rugged metal case, the HA-650 comprises a fully miniaturized transmitter and receiver, both employing rugged, heat-resistant Silicon transistors in all critical areas to assure trouble-free, dependable operation. Equipped with 14 transistors and 6 diodes, the unit employs a continuously tuned superheterodyne receiver circuit with one stage of RF and two stages of IF, and a five-stage crystal-controlled transmitter for precise dependable performance.

The transmitter is designed to operate with an input of 2.5 watts to the final RF stage, and offers up to 6 crystal-controlled frequencies in the 6-Meter Band. The unit is normally supplied without crystals but may be operated on any frequency in the 6-meter band by inserting standard 8 MC crystals into the sockets provided.

The HA-650 is equipped with a built-in battery pack designed to accept ten 1.5 volt "D" size batteries (supplied) and thus offers fully portable operation when desired. The unit may also be operated from an external 12 volt DC power source with the power cord supplied. Mobile mounting brackets and external antenna receptacle permit compact "under-dash" mobile installation using the vehicle 12 volt power supply and a body-mounted mobile antenna. Although built to withstand a certain amount of abuse, the HA-650 should be treated with the care normally accorded to electronic equipment. Always protect the unit against dirt and water, and avoid any severe shocks.

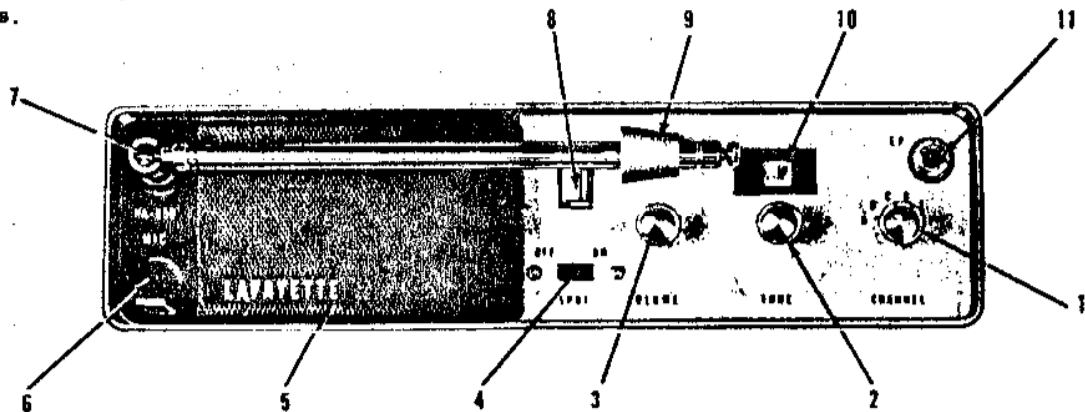

FIGURE 1

OPERATING CONTROLS AND FEATURES ON THE TRANSCEIVER

- | | |
|----------------------------|---|
| (1) CHANNEL SELECTOR | Six-position switch selects six crystal-controlled frequencies in the 50-52 Mc segment of the six-meter band. Positions A, B, C, D, E, F correspond to the six crystal sockets at the rear of the unit. |
| (2) TUNE | Dual section variable capacitor tunes the 50-52 Mc segment of the six-meter amateur band. |
| (3) VOLUME/ON-OFF | Varies the audio output from the speaker. Also incorporates an on-off power switch at the extreme counter-clockwise position. |

- (4) SPOT Controls oscillator so that transmitting frequency may be located on receiver dial.
- (5) SPEAKER 2-1/2" x 4" oval PM speaker located behind grille.
- (6) MICROPHONE Four-pin socket for push-to-talk ceramic microphone (supplied).
- (7) WHIP ANTENNA Extends to 52" for portable operation.
- (8) S-METER Indicates received signal strength in "S" units and decibels over S9. Calibrated S1 to 30 db over S9.
- (9) WHIP HOLD-DOWN CLIP Insulating plastic clamp secures collapsed whip when the HA-650 is not in use or when extended for vertically polarized operation.
- (10) RECEIVER FREQUENCY DIAL Indicates receiver frequency from 50-52 Mc. Calibrated in 100 Kc increments with direct frequency readout every 300 Kc.
- (11) PHONE JACK Accepts standard 1/4" phone plug and silences speaker when headphones are used.

INTERNAL-EXTERNAL ANTENNA SWITCH

Selects built-in whip antenna or external antenna.

EXTERNAL ANTENNA RECEPTACLE

Motorola jack accepts external six-meter antenna.

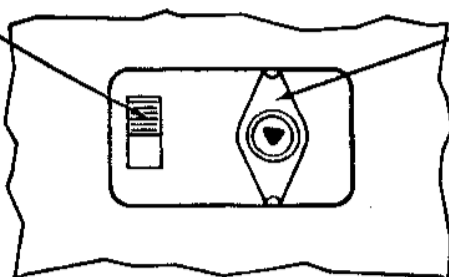

FIGURE 2

PORTABLE OPERATION

The HA-650 is supplied with a plastic battery compartment holding ten "D" size cells. The procedure for battery installation is as follows:

1. Remove the rear chassis cover by releasing the two snap latches at the sides of the transceiver.
2. Insert the ten "D" size batteries (or nickel-cadmium rechargeable cells) into the plastic compartment. Be sure to observe proper polarity. The spring always makes contact with the outside (negative) case. The positive terminal always rests in the round seat provided (see Fig. 3).
3. Place the compartment in the transceiver with the cable side down.
4. Plug the power cord into the receptacle at the rear of the transceiver.

5. Replace the rear chassis cover, making sure that the power cord is not pinched against the case, and secure the snap latches. The transceiver is now equipped for portable operation.

IMPORTANT: When the transceiver is not used for extended periods of time, be sure to remove the batteries. Failure to do so may result in battery leakage.

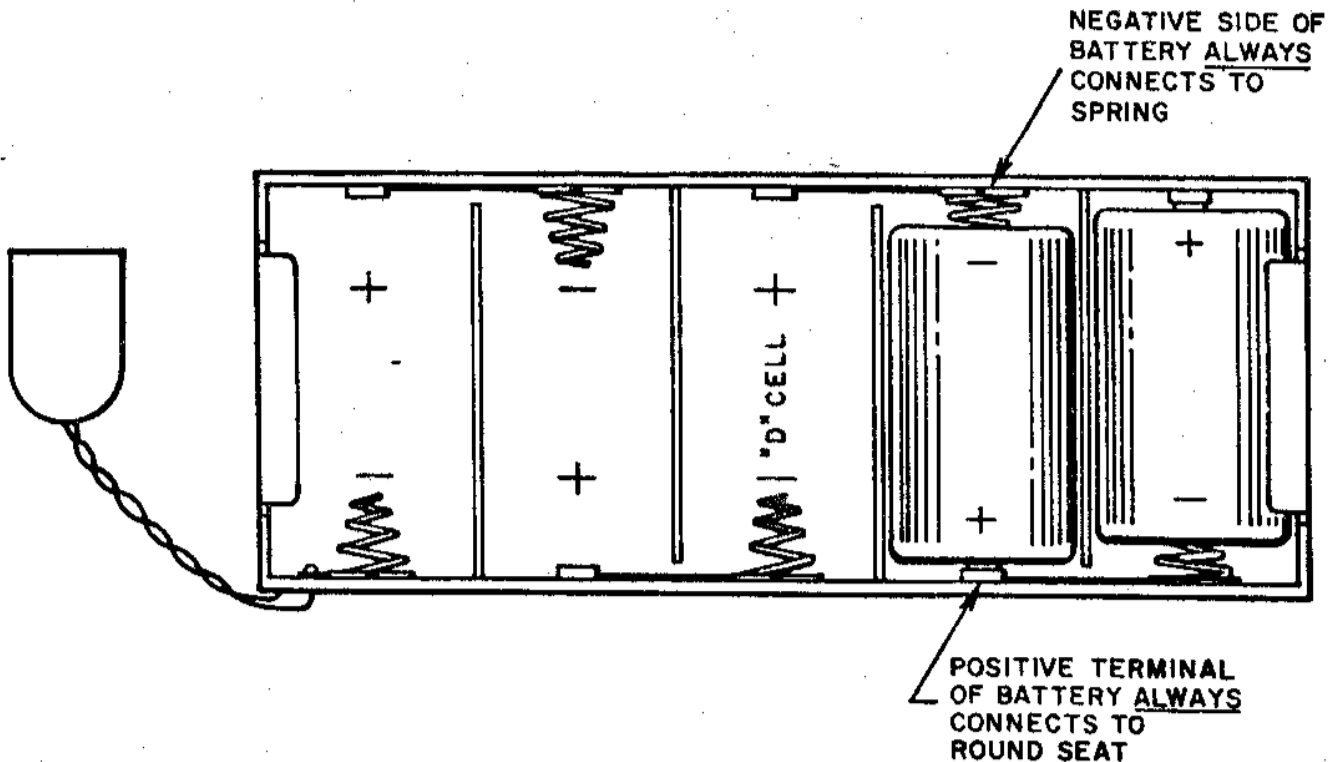

FIGURE 3

MOBILE INSTALLATION

TRANSCEIVER MOUNTING

The HA-650 may be operated from vehicles having 12-volt electrical systems. Before installing the transceiver in a car, truck, boat, etc., be sure to choose a location which is convenient to the operating controls and which will not interfere with the normal functions of the driver. The transceiver may be mounted on the underside of the instrument panel or dashboard by means of the two mounting brackets supplied. Figure 4 illustrates the correct mounting procedure.

MICROPHONE BRACKET

The design of the HA-650 prohibits mounting a microphone bracket directly to the chassis. We recommend, therefore, that the microphone bracket be attached to the mounting bracket using the screws provided (see Fig. 5).

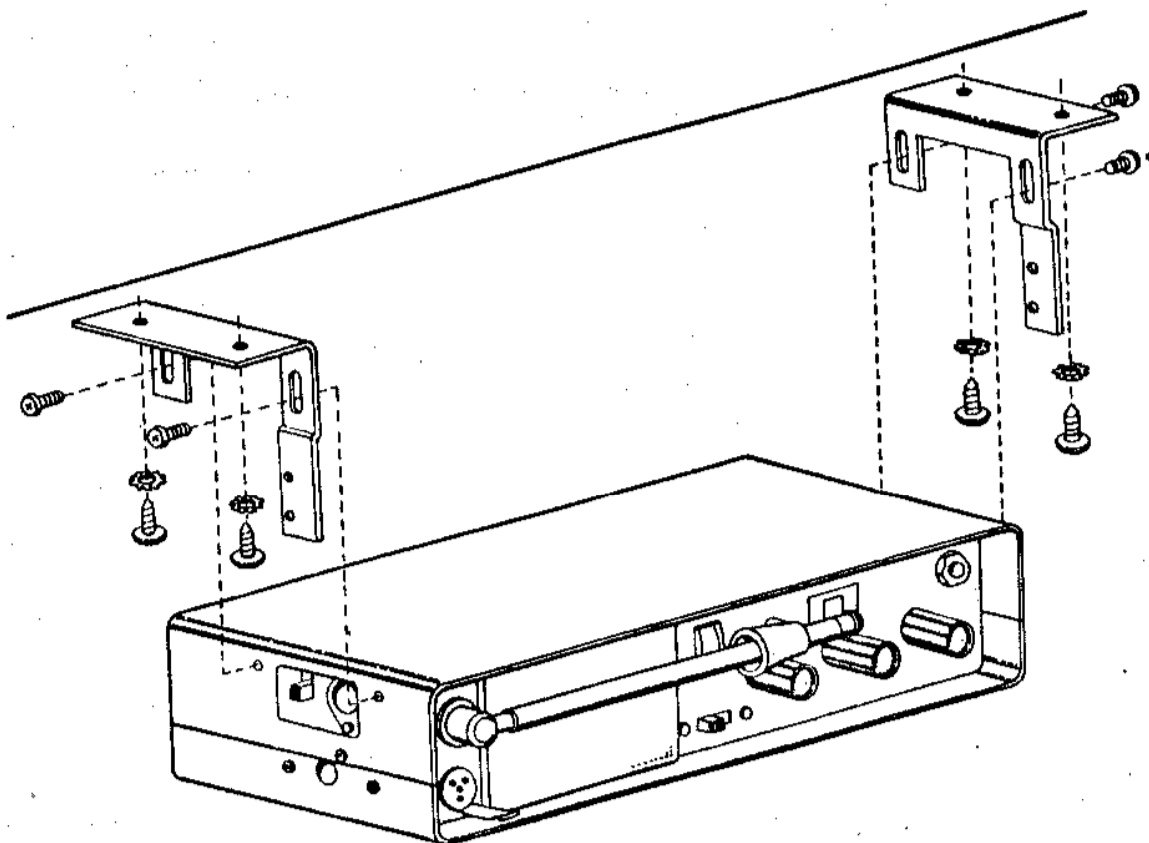
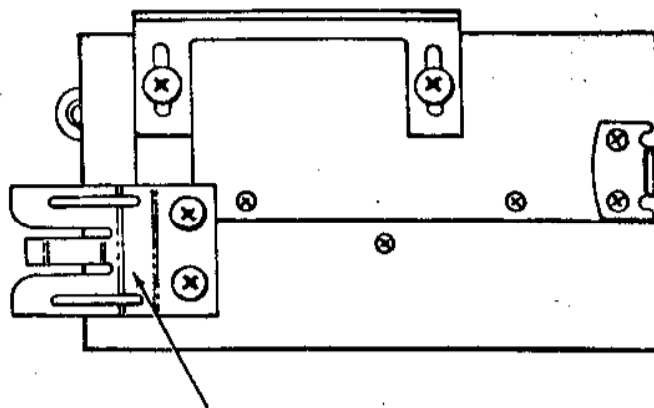

FIGURE 4



MICROPHONE BRACKET

FIGURE 5

MOBILE POWER CONNECTIONS

WARNING: As Supplied, the HA-650 Is Wired To Operate From A Battery Source Of 11.5 To 14.5 Volts DC On Negative Ground Systems. Connecting The Unit To A Positive Ground Vehicle Without Making The Necessary Internal Wiring Change Will Severely Damage The Transceiver. Before Making Any Power Connections You Must Determine Whether The Vehicle Has A Negative Or Positive Ground Electrical System And Follow The Appropriate Instructions Below.

If installed in a boat, the transceiver will not operate at maximum efficiency without a ground plate, unless the vessel has a steel hull. However, before installing the transceiver, consult a qualified marine technician regarding an adequate grounding system.

NEGATIVE GROUND

Connect the fused power lead (RED) of the DC power cord to the positive or "hot" side of the electrical system. Points normally available for this purpose are the accessory post on the ignition switch, the voltage regulator side of the ammeter or the accessory side of the fuse block. The other lead (BLACK) should be connected to the metal firewall or any other point that is connected to the vehicle chassis.

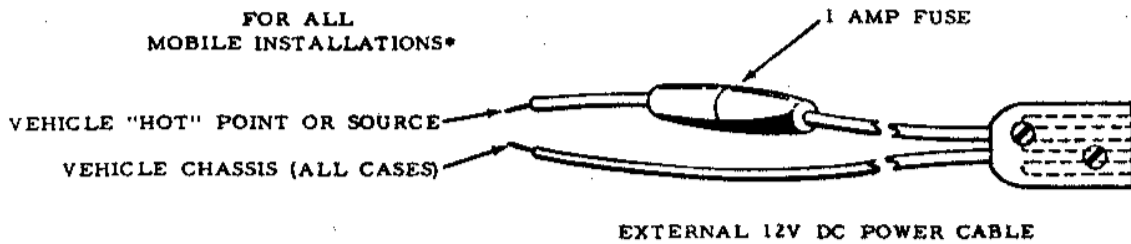

FIGURE 6

POSITIVE GROUND

Before using the HA-650 for operation in vehicles with a positive ground electrical system, the following internal wiring change must be made. Remove the rear battery cover by releasing the two snap latches at the sides of the unit. Remove the two Phillips head screws holding the top cover on each side of the unit. Carefully lift off the top chassis cover. Locate the Negative Ground - Positive Ground exchange wires behind the phone jack (see Fig. 7).

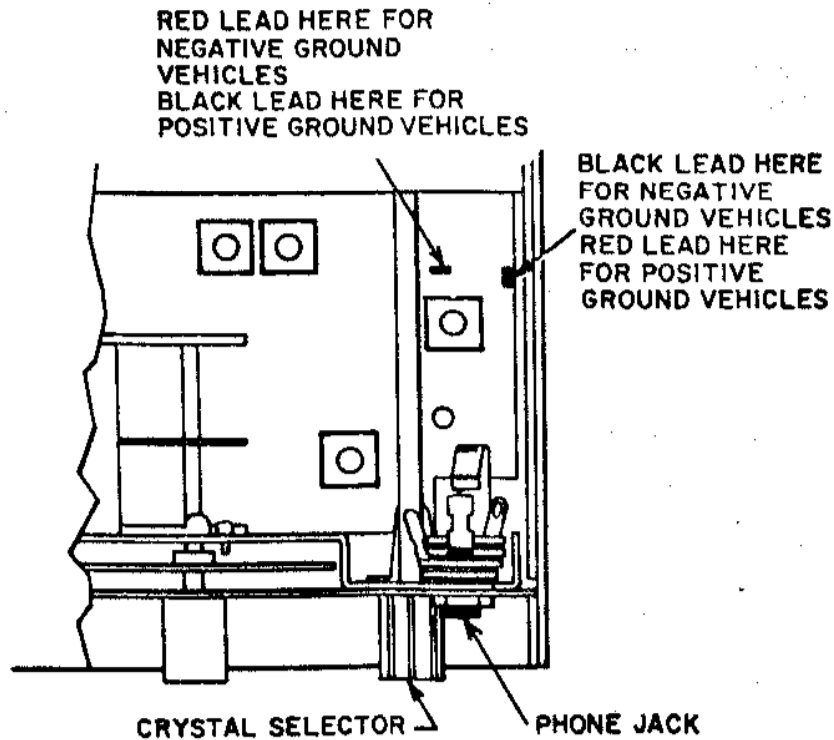

FIGURE 7

Carefully pull the lugs upward and interchange the two leads, i. e., put the Red lead where the Black lead was and the Black lead where the Red lead was. Again see Figure 7. Replace the top cover, all screws, and the battery cover.

Connect the DC power cord as follows: Connect the fused (red) lead to the vehicle "hot" point or source (in the case of positive ground vehicles this is the negative battery side). Connect the black lead to the vehicle chassis, or any other point that is connected to the chassis.

After the power cable has been properly connected to the vehicle's electrical system, remove the rear chassis cover by releasing the two snap latches and plug the DC power cable into the socket provided. Notice that the pins are unequally spaced, allowing the plug to be inserted in only one direction. Be sure to position the cable in the notch on the transceiver's rear chassis cover. Replace the cover and fasten the two snap latches.

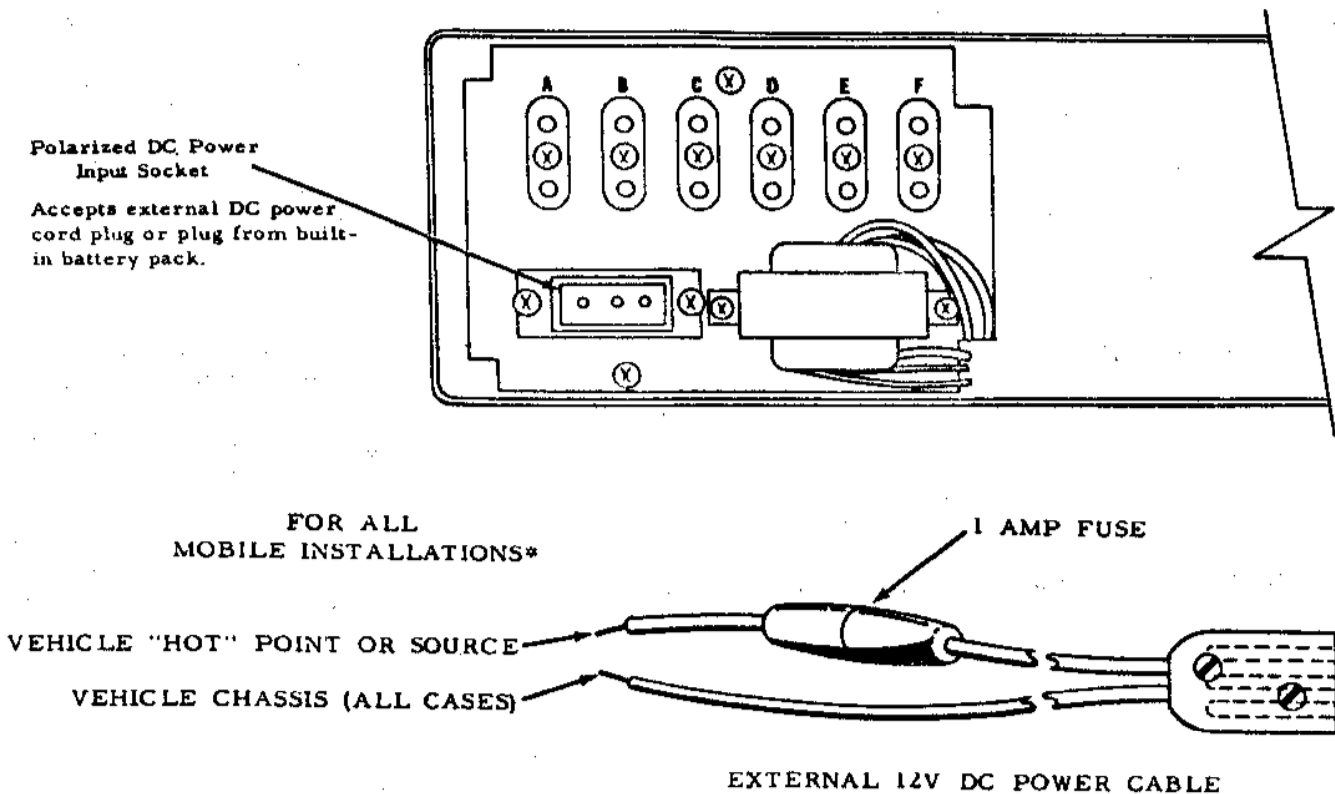

FIGURE 8

OPERATION WITH THE HB-501 POWER SUPPLY

The HA-650 may be operated in a permanent type installation using any power supply capable of providing 12 volts DC at 1/2 ampere. One such supply is the Lafayette Model HB-501 solid-state power supply. The power cable on the HB-501 plugs directly into the power receptacle on the HA-650.

1. Remove the rear chassis cover of the HA-650 by releasing the two snap latches.
2. Insert the HB-501 12-volt DC power cable into the power socket on the HA-650. Be sure to position the cable in the notch on the transceiver's rear chassis cover.
3. Replace the chassis cover and fasten the two snap latches.

The HA-650 may be placed vertically at the rear of the HB-501 power supply.

ANTENNAS

The HA-650 is supplied with a 52-inch collapsible whip for portable use and an antenna switch and Motorola type antenna jack for use with external antennas.

WARNING: Do not transmit with the HA-650 unless the antenna switch is in the proper position. Severe damage to the output transistor will occur if the transceiver is operated without a proper load.

WHIP ANTENNA

Place the red antenna switch on the left side of the unit in the INT position. Extend the whip to its maximum length (52 inches). Antenna polarization is very important at these frequencies and should be considered when choosing an operating position. Generally speaking, the antenna polarization should be compatible with that of the stations with which you expect to communicate (i.e., vertical to vertical, horizontal to horizontal). Normally, for portable operation, or any operation with the whip antenna, vertical polarization will probably be most convenient and provide the best results. When used in the vertical position, slide the plastic hold-down clamp to the base of the whip and push it over the swivel ball. This will provide greater rigidity and maintain the whip in the vertical position.

EXTERNAL ANTENNA

Any six-meter antenna presenting 52 ohms impedance to the HA-650 may be used. The antenna switch must be in the EXT position and the antenna should be connected to the antenna receptacle on the side of the unit using RG-8/U or RG-58/U coaxial cable and a Motorola antenna plug. Should your antenna transmission line already have a PL-259 coaxial connector attached, an adapter (Lafayette #42-3206) is available to adapt the PL-259 to a Motorola type plug. Instructions for attaching the cable to the plug appear below and are illustrated in Figure 9.

Additional information on antennas may be found in the ARRL Antenna Book, ARRL Radio Amateur's Handbook, Radio Handbook or other authoritative references on the subject.

ATTACHING COAXIAL CABLE TO A MOTOROLA PLUG

1. To prepare the coaxial cable, remove 1-1/8" of outer insulation as shown in "A" of the diagram. Be careful not to cut into the shield. Push the shield back exposing the dielectric and the center conductor. Bend the cable as shown in "B" and, using a pointed tool, spread the shielding at the bend. Pull the center conductor through this opening as shown in "C". Using pliers, squeeze the shield flat and cut to a length of 1". Remove 7/16" of the center conductor insulating dielectric and twist the stranded wire as shown in "D".
2. Bend the shield back along the black outside insulation and insert the prepared cable into a Motorola plug (Lafayette #11-6603) allowing the center conductor to pass through the small opening at the front of the plug (see "E"). Bend the shield over the connector as shown in "F" and solder.
3. Cut off the center conductor flush with the small opening and solder (see "G").

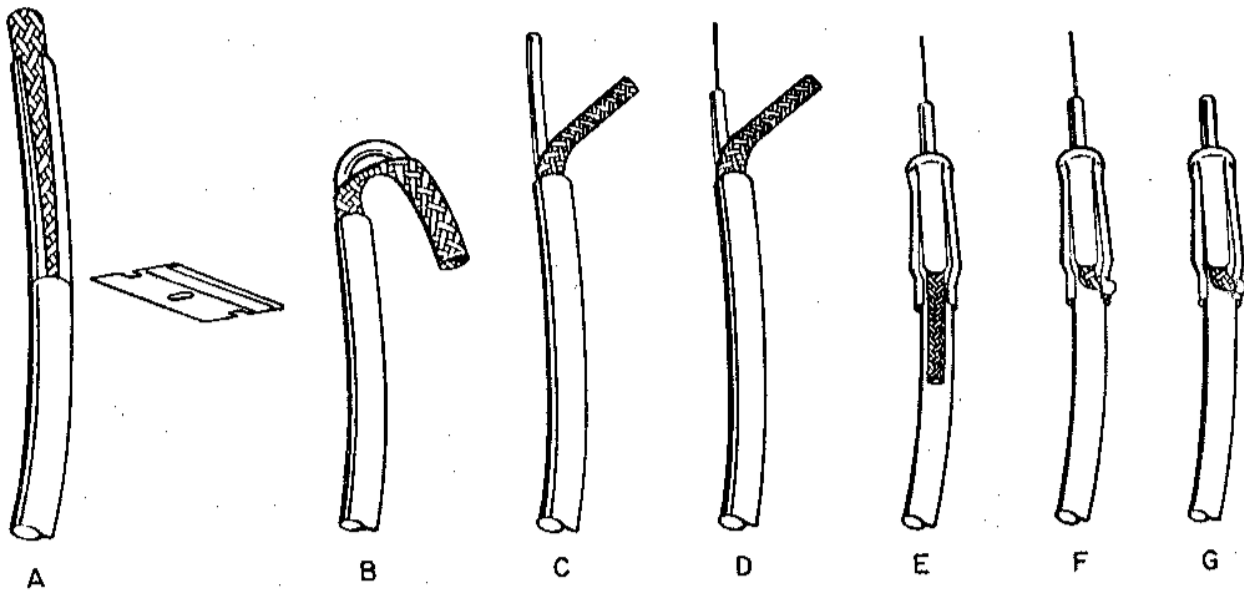

FIGURE 9

INSERTING CRYSTALS

Remove the HA-650 from its leather carrying case and remove the rear chassis cover by releasing the two snap latches at the sides of the unit. This will reveal the six crystal sockets. Use only crystals having a fundamental frequency between 8 and 9 megacycles with pin diameter of .093" and pin spacing of .486". To determine the required fundamental frequency, divide the six-meter operating frequency by six. The six-meter phone and CW frequency allocation is:

CW	PHONE
50-54 Mc	50.1-54 Mc

Since this transceiver is equipped for phone operation between 50.1 and 52 Mc, crystals having a fundamental frequency between 8350 and 8666 Kc must be used. A convenient chart for the six crystal positions in the transceiver is shown below.

CRYSTAL SELECTOR POSITION	CRYSTAL FUNDAMENTAL FREQUENCY	SIX-METER FREQUENCY
A		
B		
C		
D		
E		
F		

FIGURE 10

DAMAGE IN SHIPMENT

If your HA-650 six-meter transceiver was damaged in shipment, obtain a report from your express agent or trucker and mail it to:

LAFAYETTE RADIO ELECTRONICS CORPORATION
111 JERICHO TURNPIKE
SYOSSET, L.I., NEW YORK 11791

Do not return the unit until you receive instructions from us.

RETURNING THE UNIT FOR REPAIR

If you wish to return the unit for repair (either in or out of warranty), we recommend that you return the transceiver to the Lafayette store from which it was purchased. If the unit is to be shipped to our main office for service, please read the instructions which follow.

SHIPPING INSTRUCTIONS

Pack the unit very carefully to avoid damage in transit, preferably in its original carton. If the original carton is not available, use a sturdy carton with at least 3 inches of shredded paper or excelsior around the unit. In the latter case, wrap the unit in paper first to avoid particles of packing material getting into it. Bear in mind that the carrier will disclaim responsibility for damage, if, in his opinion, it was caused by improper packing. **INCLUDE WITH THE UNIT A LETTER EXPLAINING EXACTLY WHAT DIFFICULTIES YOU HAVE ENCOUNTERED** (remember to add an additional 5¢ postage and indicate on the outside of the carton that First Class Mail is enclosed). Include your own name and address on the carton, ship by prepaid REA express (Railway Express Agency) and mark **ELECTRONIC EQUIPMENT - FRAGILE**.

Clearly address the carton as follows:

SERVICE DIVISION
LAFAYETTE RADIO ELECTRONICS CORP.
111 JERICHO TURNPIKE
SYOSSET, L. I., N. Y. 11791

The unit will be returned to you express collect.

SERVICE FACILITIES

This manual contains a layout diagram identifying transistors, transformers, coils, etc., and a schematic diagram. Also included are instructions for aligning the receiver and transmitter sections.

REMOVING THE TOP COVER

All adjustments may be made on the HA-650 by removing the top cover only. To do this, first remove the rear battery cover by releasing the two snap latches at the sides of the unit. Remove the battery pack and plug or external power supply cable. Then remove the two Phillips head screws on each side of the unit securing the top cover. Carefully remove the top chassis cover.

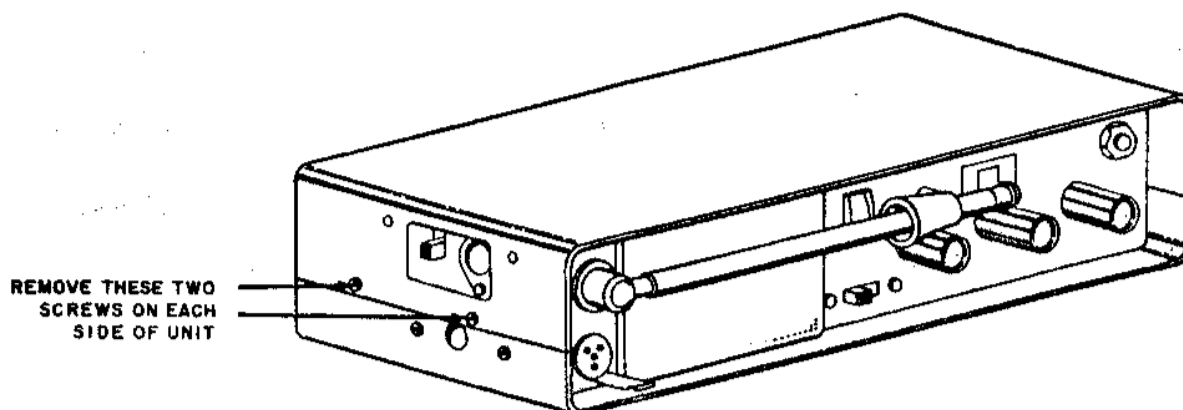

FIGURE 11

ALIGNMENT INSTRUCTIONS

The transceiver has been fully aligned at the factory before shipment to you and does not normally require further adjustment. When necessary, however, the receiver and transmitter may be aligned as indicated.

RECEIVER ALIGNMENT

1. Connect an external 12 volt DC power source to the transceiver.
2. Connect an RF Signal Generator to the external antenna receptacle on the transceiver. Make sure the antenna switch is in the "EXT" position.
3. Set the generator frequency to 50.5 Mc and adjust the generator output for a signal of approximately 10 μ V, modulated at 400 cps.
4. Tune the receiver dial to the 50.5 Mc generator signal.
NOTE: The "S" meter should read S5-S6. If it does not, reduce or increase the generator output to obtain this reading.
5. Tune L2, L4, L5, L6 and L7 for a maximum reading on the "S" meter.
6. Set the receiver and generator to 50 Mc.
7. Adjust L3 for a maximum reading on the "S" meter.
8. Set the receiver and generator to 51.5 Mc.
9. Adjust VC-1 for maximum reading on the "S" meter.
10. Repeat steps 6 and 7 and then steps 8 and 9 until no further result is observed.

NOTE: L8 and VC-2 do not require alignment outside of the factory. Do not attempt to adjust them unless they have obviously been tampered with. If it is necessary to adjust L8 for a maximum reading on the "S" meter be sure to carefully melt the waxen seal on the coil. Failure to do so may result in a damaged core.

TRANSMITTER

IMPORTANT. Before attempting to place the HA-650 in the transmit mode you must check the following.

- a) If you are using the built-in whip, always make sure it is fully extended and that the antenna switch is in the "INT" position.
- b) If you are using the external antenna jack on the HA-650, always make sure the antenna switch is in the "EXT" position.

REMEMBER, TRANSMITTING WITHOUT A PROPER ANTENNA LOAD WILL DESTROY THE FINAL RF OUTPUT TRANSISTOR.

NOTE: When aligning the transmitter section be sure to use a crystal in your preferred section of the band.

1. Connect an RF wattmeter (52 ohms) to the external antenna jack on the transceiver and plug in the microphone. Set the antenna switch to "EXT".
2. Rotate the slug of L15 clockwise to the point where oscillation begins. Advance the slug 3 1/2 turns further.

3. Adjust L9, L10, L11, L12 and L14 for a maximum reading on the RF wattmeter.
4. Adjust VC-3 for a maximum reading on the RF wattmeter.
5. Whistle a steady tone into the microphone and adjust VC-4 for a maximum reading on the wattmeter.
6. Disconnect the RF wattmeter, switch the antenna switch to the "INT" position and fully extend the whip antenna. Locate a relative power output (field strength) meter several feet from the antenna.
7. Adjust VC-5 for maximum power output on the meter.

NOTE: L16 and L17 are band-pass coils which have been carefully pre-adjusted at the factory for optimum results. Do not, therefore, make any attempt to adjust these coils.

L15, TR-10, TR-14 located beneath capacitor (see next page)

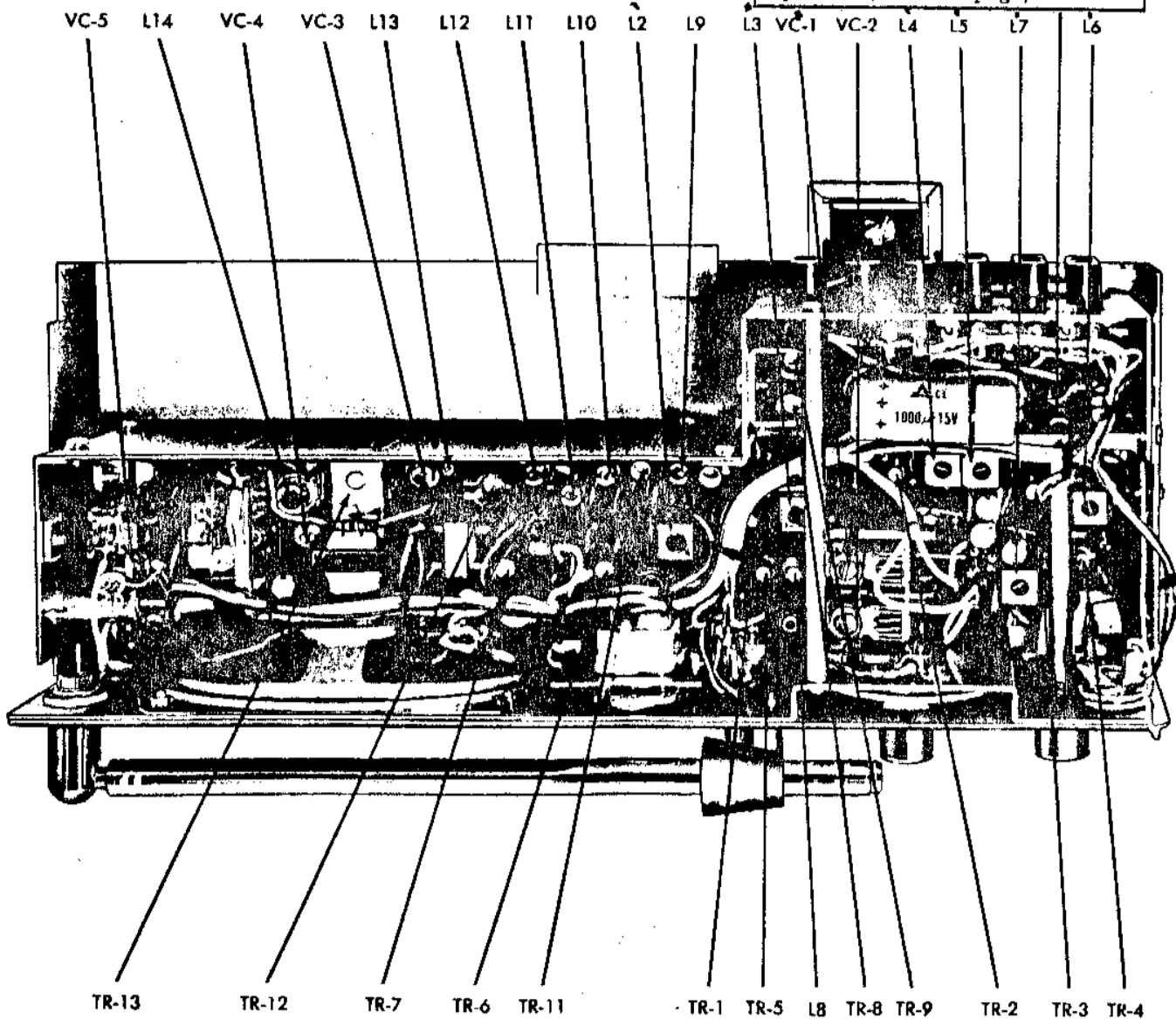
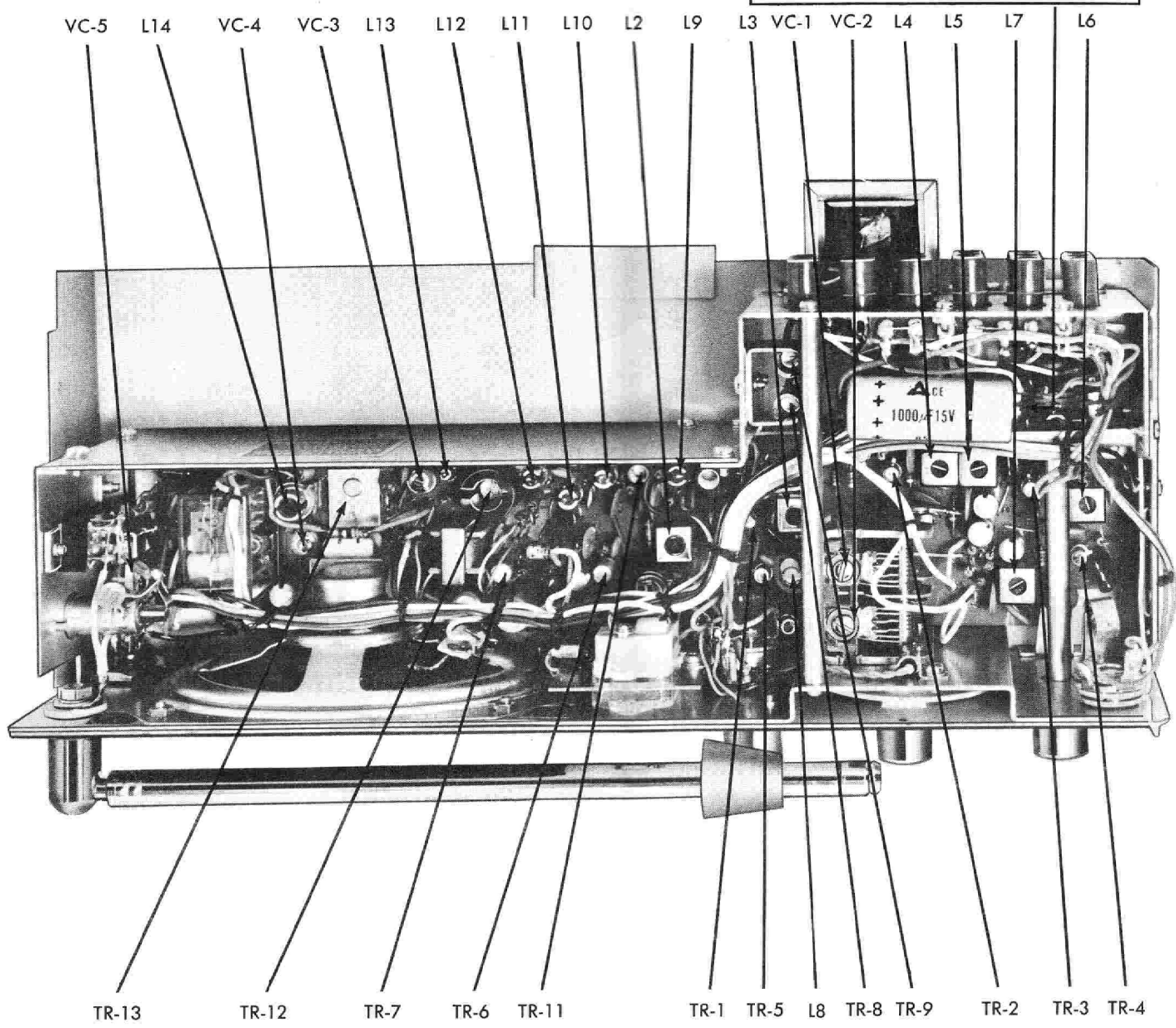
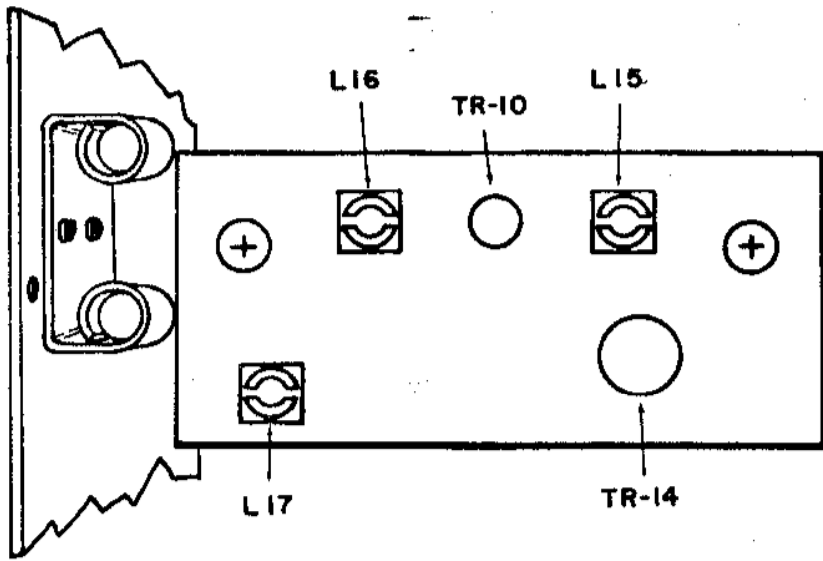
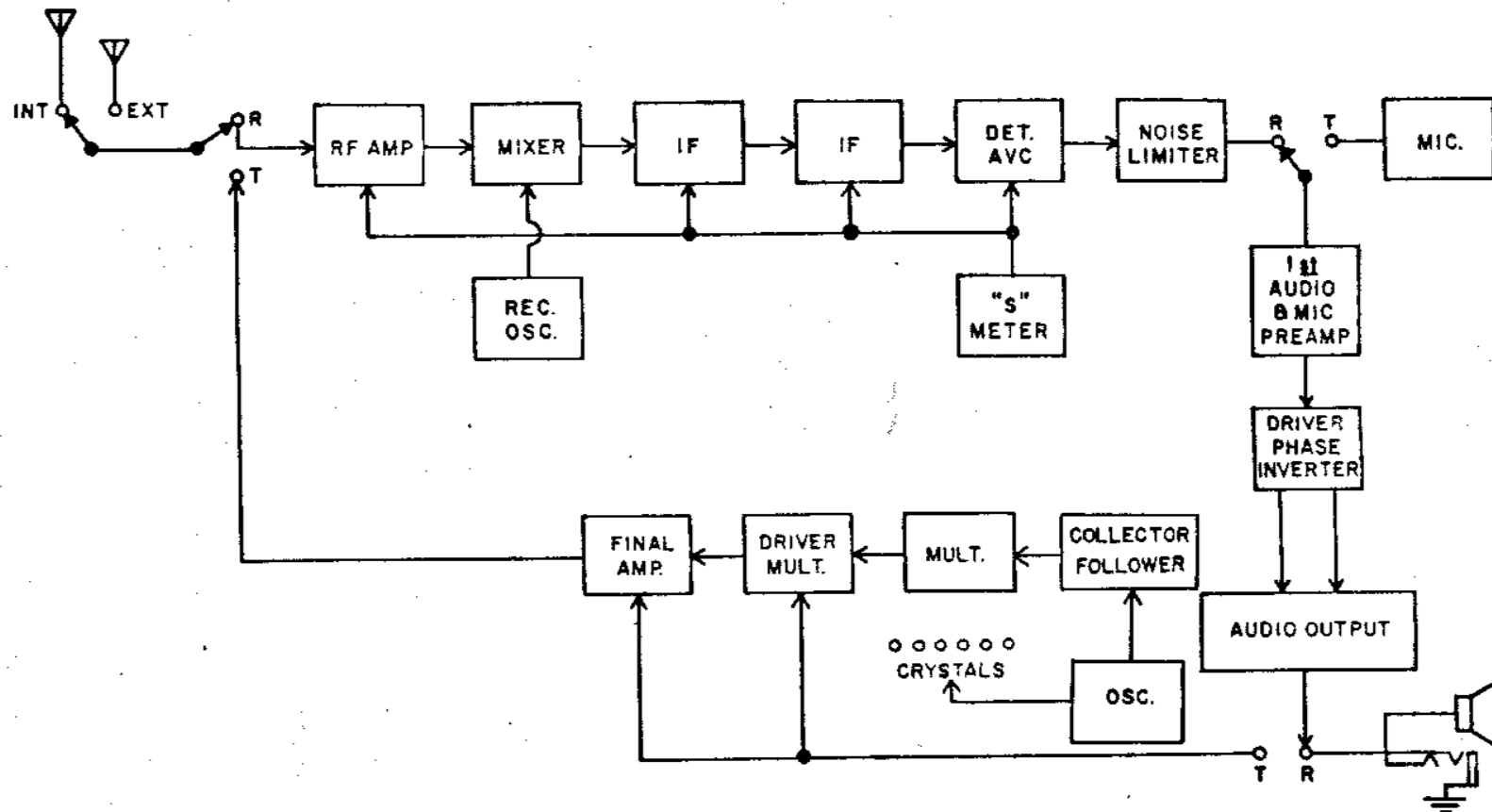

FIGURE 12







HA-650 FUNCTIONAL BLOCK DIAGRAM

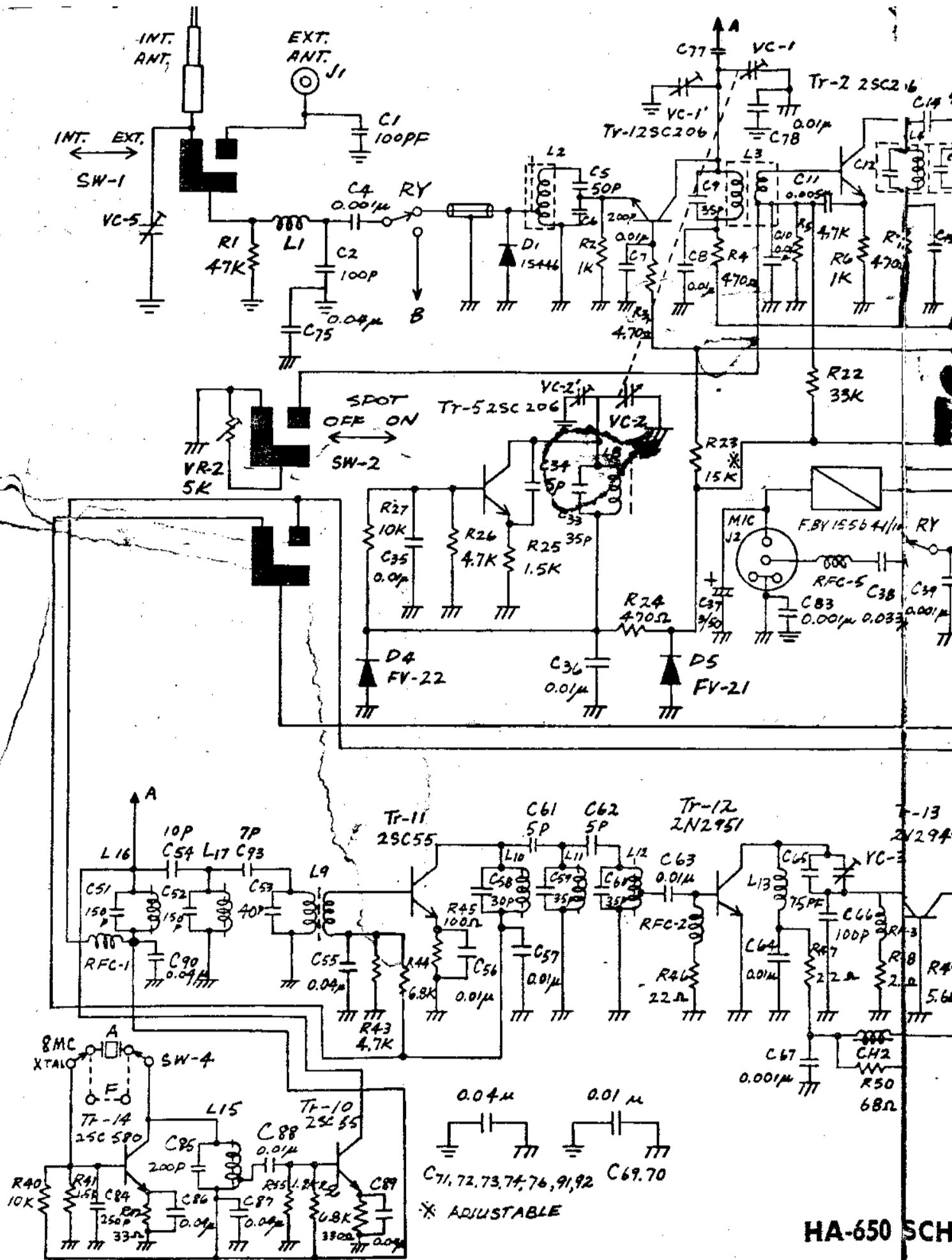

HA-650 SCH

